

500 kVA

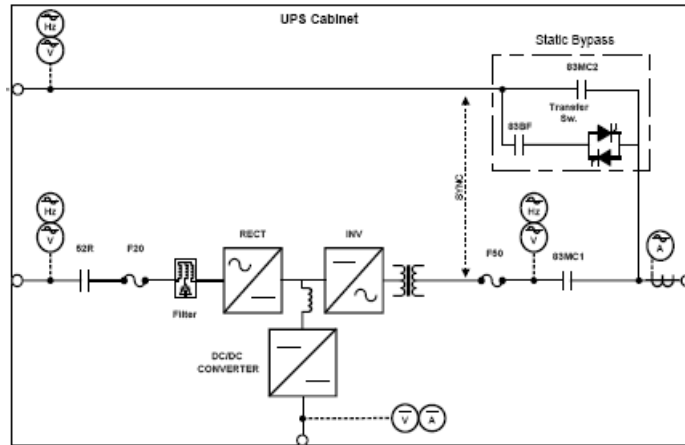

Features at-a-glance

- | | | |
|--|---|--|
| <ul style="list-style-type: none"> Single/Parallel in one box for modular design Parallel Circuits in each UPS for reliability True Online, Double-Conversion Technology Dual Input Design (Alternate Input for bypass) Static Bypass Switch <ul style="list-style-type: none"> Thyristor + Contactor for highest reliability | <ul style="list-style-type: none"> LCD Touch screen Graphic Display IGBT Inverter – Space Vector Modulation Output Isolation Transformer All Digital Signal Processor (DSP) software logic using 12 bit processor Front Access for Installation and Maintenance. Top Access for Power Cables. | <ul style="list-style-type: none"> Battery Temperature Compensation Generator Compatible 1.1:1 Monitoring Options <ul style="list-style-type: none"> RemotEye II (SNMP/Web) Memory Card w/software Dry Contacts |
|--|---|--|

Input Specifications

Voltage range: 480V +15% -15%
 (Optional Cabinet for 208V, 600V)
 Frequency range: 60Hz, +/- 5%
 Power factor: >0.98
 Input current THD: less than 6% at 100% load
 Surge protection: Meets ANSI C62.41

Battery Specifications

Cabinets or Racks with DC Breaker
 Battery type: Sealed Valve Regulated Lead-Acid
 Recharge time: 10 x discharge time to 90% capacity
 DC Link: 480VDC Nominal

Environmental Specifications

Ambient temperature: 0C to +40C
 Relative humidity: 5%-95% Non-Condensing
 Altitude: 0 to 9000 feet without derating
 Audible noise: Less than 78 dBA at 1 meter

Output Specifications: 500 kVA/450 kW (0.9PF)

Voltage: 480Y/277V Standard
 (Optional 600/347V)
 Voltage regulation: +/- 1%
 Freq. regulation: +/- 0.05% (Free running)
 Dynamic response: +/-2% at 100% step load
 (recovery in less than 1 cycle)

Voltage Distortion:
 Less than 2% for 100% linear load
 Less than 5% for 100% non-linear load
 Freq. sync range: +/- 5% (user selectable)
 Freq. slew rate: 1 – 10 Hz/second (user selectable)
 Voltage adjustment: +/-5% (user selectable)
 Overload capacity: 500% for 1 cycle
 150% for 1 minute
 125% for 10 minutes
 Crest Factor: 2.3 : 1

Safety

UL/CUL 1778 Listed
 All cabinets provide for seismic zone 4 mounting

Options

Input/Output Transformer Cabinet
 Maintenance Bypass Cabinet
 RemotEye II™ Network Adapter
 “Security Plus” Maintenance Agreement

G8000MM 500 kVA UPS Specifications

Item: T8MS3K50KK6XSN		500
		500kVA/450kW
Input Voltage	Volts	480
Output Voltage	Volts	480/277
Input Voltage Range		+15% to -15%
Minimum	Volts	408
Maximum	Volts	552
Frequency	Hz	60
AC Input Current		(> 0.98 PF)
Nominal Amps	Amps	587
Maximum Amps ⁽¹⁾	Amps	624
Bypass Input	Volts	480/277
Nominal Amps	Amps	601
AC Output Current		(at 0.9 PF)
Nominal Amps	Amps	601
10 Minutes Max.	Amps	753

Item: T8MS3K50KK6XSN		500
		500kVA/450kW
DC Link		
Nominal DC Voltage	Volts	480
Float Voltage	Volts	545
End of Discharge	Volts	400
Charger	Amps	65 (Max)
Efficiency		
Efficiency	%	94.1

Full Load Heat Dissipation		
BTU/Hr.		96,271
kW		28.2

(1) Maximum Amps equals full load current plus battery recharge current.

G8000MM 500 kVA UPS Specifications

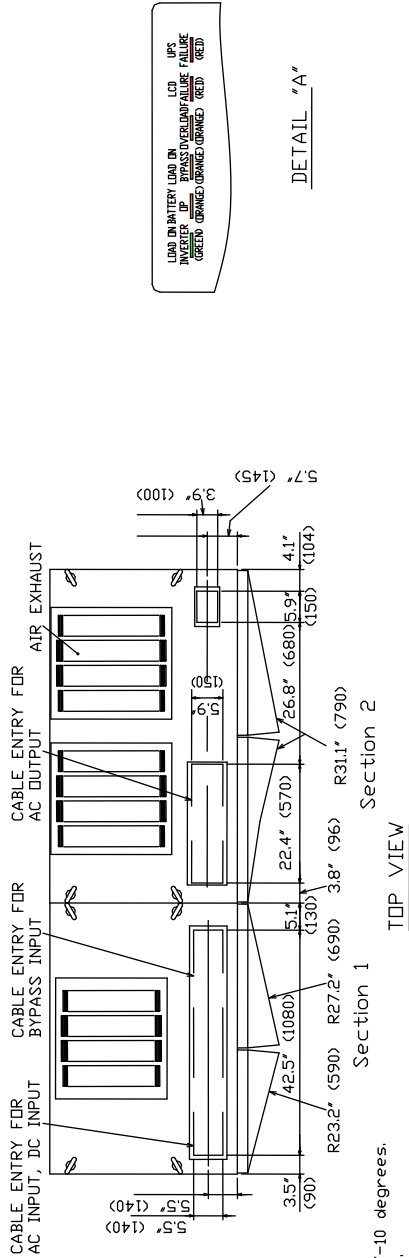

- NOTES**
1. Cabinets must be maintained upright +/-10 degrees.
 2. Paint finish is color number 28Y7.7/D3.
 3. Dimensions are inches (mm).

