

Product Brief

ARM Product Brief

Highlights

- Toshiba takes a system-level approach to designing with ARM cores by incorporating top-down design using system description languages and complete software support.
- Toshiba provides the industry's most advanced process technologies, a comprehensive library of IP, with eDRAM and high-speed I/O, state-of-the-art manufacturing and worldwide expert Design Centers.
- Toshiba's ARM-based SoC designs are used in a wide range of applications including digital consumer, networking, mobile/storage and security.

Toshiba Customized Silicon Solutions

Toshiba is the third largest¹ semiconductor company in terms of global sales, and designs and manufactures many of the world's most complex system-on-chip (SoC) designs. Toshiba Custom SoC solutions are developed using several advanced ASIC methodologies. These methodologies are implemented in a range of deep sub-micron processes from 0.25-micron to 40 nm. Toshiba manufacturing processes use a modular approach to enable quick implementation of new capabilities and have already achieved full production.

The Custom SoC solution can incorporate a broad selection of cores including embedded DRAM, high-speed I/O and SERDES, mixed-signal ADC, DAC, PHY, etc. The range of digital IP available includes an extensive selection of both Toshiba internally developed IP and third-party IP. This includes broad support for the ARM series of microprocessor cores and its associated peripherals. The ARM cores have been used in over six generations of technology and are fully supported by U.S.-based Toshiba Design Centers.

Supported ARM Cores

- ARM7TDMI-S
- ARM926EJ-S
- ARM946ES
- ARM1026EJ-S
- ARM1136J-S
- ARM1176JZF-S
- Cortex-M3
- Cortex-R4
- Cortex-A9

Toshiba Libraries

- Verilog-XL, LDDL2, Synopsys, DLL, PLL, ADC, DAC, USB PHY, PCIe PHY, DDR2 PHY, etc.

PrimeCell Peripherals

- CoreSight DK, ETM
- L2 Cache Controller
- SoC Designer and AMBA Designer
- AXI fabric
- UART with IrDA
- Synchronous Serial Interface
- Real Time Clock
- Audio Codec Interface (ACI or AACI)
- Keyboard/Mouse I/F

- DDR/DDR2 SDRAM Controller
- NOR Flash Controller
- Vector Interrupt Controller
- Color LCD Controller and others

Toshiba and Third-Party Peripherals

- DDR2 SDRAM Controller
- Ethernet MAC 10/100 and 10/100/IG
- USB Controller (1.1 & 2.0)
- PCMCIA Controller
- PCIe Controller
- I²C
- Compact Flash Controller
- NAND Flash Controller
- DMA Controller
- Static Memory Interface (SRAM/Flash & ROM)
- SmartCard Interface
- AC to DC Converter Interface

Support

For each ARM-based ASIC design, a Toshiba engineering team is assembled to help customers create the best design based on system-chip architecture tradeoffs, silicon technology, cell

¹ Gartner: World's Top 10 Semiconductor Supplier Rankings for 2007, April 2008

libraries, IP, EDA tools, design flows, test, packaging, quality assurance and other criteria. Depending on each customer's own resources and skills, Toshiba engineers can work as expert consultants or provide access to Toshiba's sophisticated design tools, including a comprehensive ARM Design Kit that includes models, system components, bus fabric and peripheral IP.

Design Kit

- CPU Core Design
DSM (Design Sign-off C Models) with Verilog timing wrappers available in Verilog, VCS, NC-Verilog or VHDL format

System Components

The AMBA Design Kit (ADK), SoC Designer & AMBA Designer, PL301 AXI fabric.

Peripheral IP

- PrimeCell Peripherals from ARM (some requires a per-use fee)
- Available in Verilog or VHDL format
- Other Toshiba or Third-party developed IP

General Block Diagram

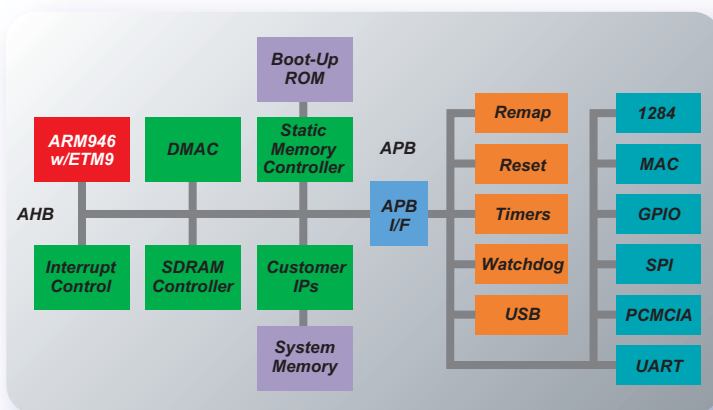

Core Specifications

ARM7TDMI

Features:

- 32/16-bit RISC architecture (ARM v4T)
- 32-bit ARM instruction set for maximum performance and flexibility
- 16-bit Thumb instruction set for increased code density
- Unified bus interface, 32-bit data bus carries both instructions and data
- Three-stage pipeline
- 32-bit ALU and high-performance multiplier
- Very small die size and low-power consumption
- Fully static operation
- Coprocessor interface
- Extensive debug facilities:
 - EmbeddedICE-RT real-time debug unit
 - JTAG interface unit
 - Interface for direct connection to Embedded Trace Macrocell (ETM)

ARM926EJ-S

Features:

- 32/16-bit RISC architecture (ARMv5TEJ)
- 32-bit ARM instruction set for maximum performance and flexibility
- 16-bit Thumb instruction set for increased code density
- DSP instruction extensions and single cycle MAC
- ARM Jazelle technology Java bytecode acceleration embedded within the core:
 - 12K gates of logic
 - 0.075 mW per Caffeine Mark (CM)
 - 6 CM/MHz = 1200 Caffeine Marks @ 200 MHz
- MMU which supports operating systems including Symbian OS, Windows CE, Linux
- Flexible instruction and data cache sizes
- Instruction and data TCM interfaces with wait state support
- EmbeddedICE-RT logic for real-time debug
- Industry standard AMBA bus AHB interfaces
- ETM interface for real-time trace capability with ETM9
- Floating point support with optional VFP9-S coprocessor

ARM946ES

Features:

- 32/16-bit RISC architecture (ARMv5TE)
- 32-bit ARM instruction set for maximum performance and flexibility
- 16-bit Thumb instruction set for increased code density
- Memory Protection Unit (MPU) supporting all major RTOS: VxWorks, pSOS
- Flexible instruction and data cache sizes
- Instruction and data TCM interfaces
- Industry standard AMBA AHB interface
- Floating point support with the optional VFP9-S coprocessor
- Embedded ICE-RT logic for real-time debug
- ETM interface for real-time trace capability with ETM9
- DSP instruction extensions and single cycle Mac

ARM1026EJ-S

Features:

- 32-bit RISC processor
- ARMv5TEJ architecture
- 6 stage pipeline
- 1.24 MIPS/MHz
- 16-bit fixed point DSP extension
- ARM Jazelle® technology
- MMU and MPU support
- Separate 6 4-bit or 32-bit AHB interface
- ETM10RV (Softmacro) interface
- VFP10 (Hardmacro) interface
- Direct-attach VIC interface
- 460 MHz @Toshiba 65 nm
- Instruction & data caches
 - 4-128 KB with 4 way associativity
- Configurable instruction and data TCMs
 - 0-1 MB with wait state support

ARM1136J-S / ARM1136JF-S

Features:

- ARMv6 architecture
 - ARM Jazelle® technology
 - Mixed endian data support
 - Unaligned data support
 - Physically addressed caches
 - SIMD media processing extensions
- 8 stage pipeline
- 1.2 MIPS/MHz
- MMU support
- Direct-attach VIC interface
- Vector floating point unit (ARM1136JF-S)
- Quad 64-bit AHB interface (I-fetch, D-read, D-write, DMA)
- Dedicated 32-bit peripheral port (AHB-lite)
- Branch prediction and return stack
- 550 MHz @Toshiba 65 nm
- Configurable instruction and data caches
 - 0-64KB with 4 way associativity (2 cycle access)
- Configurable instruction & data TCMs
 - 0-64 KB with DMA (2 cycle access)

ARM Cortex-M3

Features:

- Cortex – M3 core
 - Thumb-2 instructions and traditional Thumb instructions only
 - Harvard architecture
 - 3-stage pipeline with branch speculation
 - ALU with HW divide and single-cycle multiply
 - 1.25 DMIPS/MHz
- Cortex – M3 processor
 - Cortex M3 core
 - Configurable interrupt controller
 - Bus matrix
 - Advanced debug components
 - Optional MPU and ETM
 - Low-power design
 - Integrated sleep modes

TAEC Sales Offices

Toshiba America Electronic Components, Inc.

Headquarters

19900 MacArthur Boulevard
Suite 400
Irvine, CA 92612
TEL: 949-623-2900
FAX: 949-474-1330

Toshiba America Electronic Components, Inc.

2590 Orchard Parkway
San Jose, CA 95131
TEL: 408-526-2400
FAX: 408-526-2410

5959 Gateway West,
Suite 405
El Paso, TX 79925
TEL: 915-771-8156

2150 E. Lake Cook Road,
Suite 310
Buffalo Grove, IL 60089
TEL: 847-484-2400
FAX: 847-541-7287

48679 Alpha Drive #120
Wixom, MI 48393
TEL: 248-347-2607
FAX: 248-347-2602

959 Route 46 East
Parsippany, NJ 07054
TEL: 973-541-4715
FAX: 973-541-4716

290 Donald Lynch Blvd.,
Suite 201
Marlborough, MA 01752
TEL: 508-481-0034
FAX: 508-481-8828

3700 Crestwood Parkway,
Suite 1070
Duluth, GA 30096
TEL: 770-931-3363
FAX: 770-931-7602

www.Toshiba.com/taec

ARM Cortex-A9

Features:

- ARM Architecture V7 A Profile
 - Thumb-2 instructions
 - MMU
 - Security extension (ARM TrustZone® technology)
- Advanced micro-architecture
 - 2.2 DMIPS/MHz
 - Variable length, superscalar pipeline
 - Out of order execution
 - Branch prediction and return stack
 - Up to 4 decoded instructions ready to issue
 - Data engine execute in parallel to main pipeline
- Options
 - UP or MP (1-4 cores)
 - Jazelle DBX
 - FPU (provide significant for single and double precision scalar floating point operations.)
 - Neon (accelerating media and signal processing)
 - Number of interrupts 0-224
 - Trace macro
 - I&D Cache size: 16/32/64 KB
 - Single or dual AXI interface
 - Dormant or shutdown mode

* The information contained herein is subject to change without notice.

* The information contained herein is presented only as a guide for the applications of our products. No responsibility is assumed by TOSHIBA for any infringements of patents or other rights of the third parties which may result from its use. No license is granted by implication or otherwise under any patent or patent rights of TOSHIBA or others.

* TOSHIBA is continually working to improve the quality and reliability of its products. Nevertheless, semiconductor devices in general can malfunction or fail due to their inherent electrical sensitivity and vulnerability to physical stress. It is the responsibility of the buyer, when utilizing TOSHIBA products, to comply with the standards of safety in making a safe design for the entire system, and to avoid situation in which a malfunction or failure of such TOSHIBA products could cause loss of human life, bodily injury or damage to property. In developing your designs, please ensure that TOSHIBA products are used within specified operating ranges as set forth in the most recent TOSHIBA products specifications. Also, please keep in mind the precautions and conditions set forth in the "Handling Guide for Semiconductor Devices," or "TOSHIBA Semiconductor Reliability Handbook" etc.

* The Toshiba products listed in this document are intended for usage in general electronics applications (computer, personal equipment, office equipment, measuring equipment, industrial robotics, domestic appliances, etc.). These Toshiba products are neither intended nor warranted for usage in equipment that requires extraordinarily high quality and/or reliability or a malfunction or failure of which may cause loss of human life or bodily injury ("Unintended Usage"). Unintended Usage include atomic energy control instruments, airplane or spaceship instruments, transportation instruments, traffic signal instruments, combustion control instruments, medical instruments, all types of safety devices, etc. Unintended Usage of Toshiba products listed in this document shall be made at the customer's own risk.

* The products described in this document may include products subject to foreign exchange and foreign trade laws.

* The products contained herein may also be controlled under the U.S. Export Administration Regulations and/or subject to the approval of the U.S. Department of Commerce or U.S. Department of State prior to export. Any export or re-export, directly or indirectly in contravention of any of the applicable export laws and regulations, is hereby prohibited.