

TLP719

DIGITAL LOGIC GROUND ISOLATION
 LINE RECEIVERS
 MICROPROCESSOR SYSTEM INTERFACES
 SWITCHING POWER SUPPLY FEEDBACK CONTROL
 TRANSISTOR INVERTORS

The TOSHIBA TLP719 consists of a GaAlAs high-output light-emitting diode and a high-speed detector.

This unit is a 6-lead SDIP. The TLP719 is 50% smaller than the 8-pin DIP and meets the reinforced insulation class requirements of international safety standards. Therefore the mounting area can be reduced in equipment requiring safety standard certification.

The TLP719 has a Faraday shield integrated on the photodetector chip to provide an effective common mode noise transient immunity. Therefore this product is suitable for application in noisy environmental conditions.

- Open collector
- Package type : SDIP6
- Isolation voltage : 5000 Vrms (min)
- Common mode transient immunity : ± 10 kV/us(min) @ $V_{CM} = 400$ V
- Switching speed : $t_{pHL} / t_{pLH} = 0.8$ μ s (max)
 @ $I_F = 16$ mA , $V_{CC} = 5$ V,
 $R_L = 1.9$ k Ω , $T_a = 25$ $^{\circ}$ C
- TTL compatible
- Construction mechanical rating

	7.62-mm pitch standard type	10.16-mm pitch TLPXXXF type
Creepage Distance	7.0 mm (min)	8.0 mm (min)
Clearance	7.0 mm (min)	8.0 mm (min)
Insulation Thickness	0.4 mm (min)	0.4 mm (min)

- UL recognized : UL1577, File No. E67349
 - Option (D4)
 TÜV approved : EN60747-5-2
 Certificate No. R50033433
- Maximum operating insulation voltage : 890 Vpk
 Highest permissible over voltage : 8000 Vpk

(Note) When a EN60747-5-2 approved type is needed, please designate the "Option(D4)"

PIN CONFIGURATION (Top View)

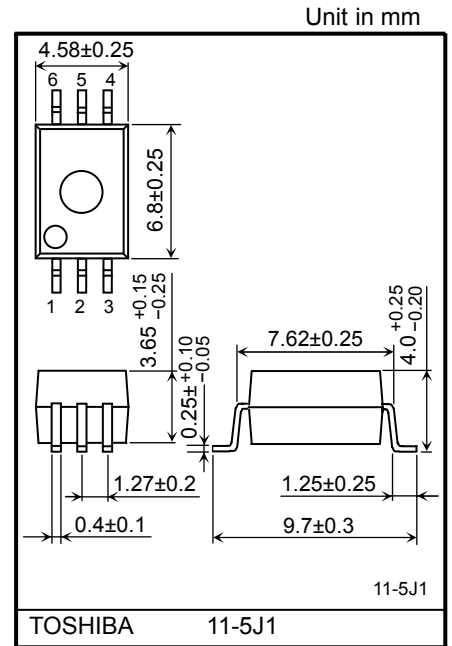
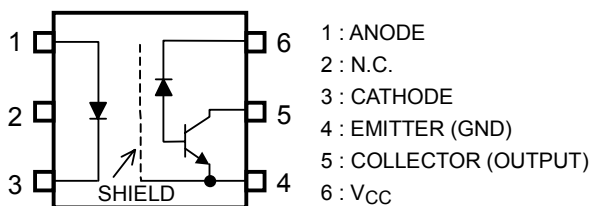

Weight : 0.26 g (typ.)

SCHEMATIC

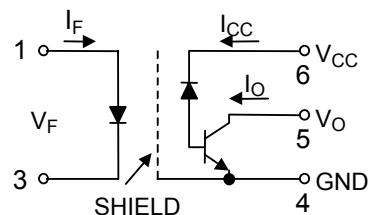

A 0.1- μ F bypass capacitor must be connected between pins 4 and 6. (See Note 7.)

Maximum Ratings (Ta = 25 °C)

Characteristic		Symbol	Rating	Unit
LED	Forward current (Note 1)	I _F	25	mA
	Pulse forward current (Note 2)	I _{FP}	50	mA
	Peak transient forward current (Note 3)	I _{FPT}	1	A
	Reverse voltage	V _R	5	V
	Diode power dissipation (Note 4)	P _D	45	mW
	Junction temperature	T _j	125	°C
Detector	Output current	I _O	8	mA
	Peak output current	I _{OP}	16	mA
	Output voltage	V _O	-0.5~20	V
	Supply voltage	V _{CC}	-0.5~30	V
	Output power dissipation (Note 5)	P _O	100	mW
	Junction Temperature	T _j	125	°C
Operating temperature range		T _{opr}	-55~100	°C
Storage temperature range		T _{stg}	-55~125	°C
Lead soldering temperature (10 s)		T _{sol}	260	°C
Isolation voltage (AC, 1 minute, R.H. ≤ 60 %)		BV _S	5000	V _{rms}

Note 1 : Derate 0.45 mA / °C above 70 °C.

Note 2 : 50% duty cycle, 1 ms pulse width.
Derate 0.9 mA / °C above 70 °C.

Note 3 : Pulse width ≤ 1 μs, 300 pps.

Note 4 : Derate 0.8 mW / °C above 70 °C.

Note 5 : Derate 1.8 mW / °C above 70 °C.

Note 6 : Device considered a two-terminal device: pins 1, 2 and 3 paired with pins 4, 5 and 6 respectively.

Note 7 : A ceramic capacitor (0.1 μF) should be connected from pin 6 to pin 4 to stabilize the operation of the high-gain linear amplifier. Failure to provide the bypassing may impair the switching property.
The total lead length between capacitor and coupler should not exceed 1 cm.

Electrical Characteristics (Ta = 25 °C)

Characteristic		Symbol	Test Condition	Min.	Typ.	Max.	Unit
LED	Forward voltage	V_F	$I_F = 16 \text{ mA}$		1.65	1.85	V
	Forward voltage Temperature coefficient	$\Delta V_F / \Delta T_a$	$I_F = 16 \text{ mA}$	—	-2	—	mV / °C
	Reverse current	I_R	$V_R = 5 \text{ V}$	—	—	10	μA
	Capacitance between terminals	C_T	$V_F = 0 \text{ V}, f = 1 \text{ MHz}$	—	45	—	pF
Detector	HIGH-level output current	$I_{OH(1)}$	$I_F = 0 \text{ mA}, V_{CC} = V_O = 5.5 \text{ V}$	—	3	500	nA
		$I_{OH(2)}$	$I_F = 0 \text{ mA}, V_{CC} = 30 \text{ V}$ $V_O = 20 \text{ V}$	—	—	5	μA
		I_{OH}	$I_F = 0 \text{ mA}, V_{CC} = 30 \text{ V}$ $V_O = 20 \text{ V}, T_a = 70 \text{ }^\circ\text{C}$	—	—	50	
	HIGH-level supply current	I_{CCH}	$I_F = 0 \text{ mA}, V_{CC} = 30 \text{ V}$	—	0.01	1	μA
	Supply voltage	V_{CC}	$I_{CC} = 0.01 \text{ mA}$	30	—	—	V
	Output voltage	V_O	$I_O = 0.5 \text{ mA}$	20	—	—	V

Coupled Electrical Characteristics (Ta = 25 °C)

Characteristic	Symbol	Test Condition	Min.	Typ.	Max.	Unit
Current transfer ratio	I_O / I_F	$I_F = 16 \text{ mA}, V_{CC} = 4.5 \text{ V}$ $V_O = 0.4 \text{ V}$	20	—	—	%
LOW-level output voltage	V_{OL}	$I_F = 16 \text{ mA}, V_{CC} = 4.5 \text{ V}$ $I_O = 2.4 \text{ mA}$	—	—	0.4	V

Isolation Characteristics (Ta = 25 °C)

Characteristic	Symbol	Test Condition	Min.	Typ.	Max.	Unit
Capacitance input to output	C_S	$V = 0 \text{ V}, f = 1 \text{ MHz}$ (Note 6)	—	0.8	—	pF
Isolation resistance	R_S	R.H. $\leq 60\%$, $V_S = 500 \text{ V}$ (Note 6)	1×10^{12}	10^{14}	—	Ω
Isolation voltage	BV_S	AC, 1 minute	5000	—	—	V_{rms}
		AC, 1 second, in oil	—	10000	—	
		DC, 1 minute, in oil	—	10000	—	Vdc

Switching Characteristics (Ta = 25 °C, VCC = 5 V)

Characteristic	Symbol	Test Circuit	Test Condition	Min.	Typ.	Max.	Unit
Propagation delay time (H→L)	t_{pHL}	Fig1	$I_F = 0 \rightarrow 16 \text{ mA}$ $R_L = 1.9 \text{ k}\Omega$	—	—	0.8	μs
Propagation delay time (L→H)	t_{pLH}		$I_F = 16 \rightarrow 0 \text{ mA}$ $R_L = 1.9 \text{ k}\Omega$	—	—	0.8	μs
Common mode transient immunity at logic HIGH output (Note 8)	CM_H	Fig2	$I_F = 0 \text{ mA}$ $V_{CM} = 400 \text{ Vp-p}$ $R_L = 1.9 \text{ k}\Omega$	10000	—	—	$\text{V} / \mu\text{s}$
Common mode transient immunity at logic LOW output (Note 8)	CM_L		$I_F = 16 \text{ mA}$ $V_{CM} = 400 \text{ Vp-p}$ $R_L = 1.9 \text{ k}\Omega$	-10000	—	—	$\text{V} / \mu\text{s}$

Note 8 : CM_L is the maximum rate of fall of the common mode voltage that can be sustained with the output voltage in the logic LOW state ($V_O < 0.8 \text{ V}$).

CM_H is the maximum rate of rise of the common mode voltage that can be sustained with the output voltage in the logic HIGH state ($V_O > 2 \text{ V}$).

Figure 1. Switching Time Test Circuit

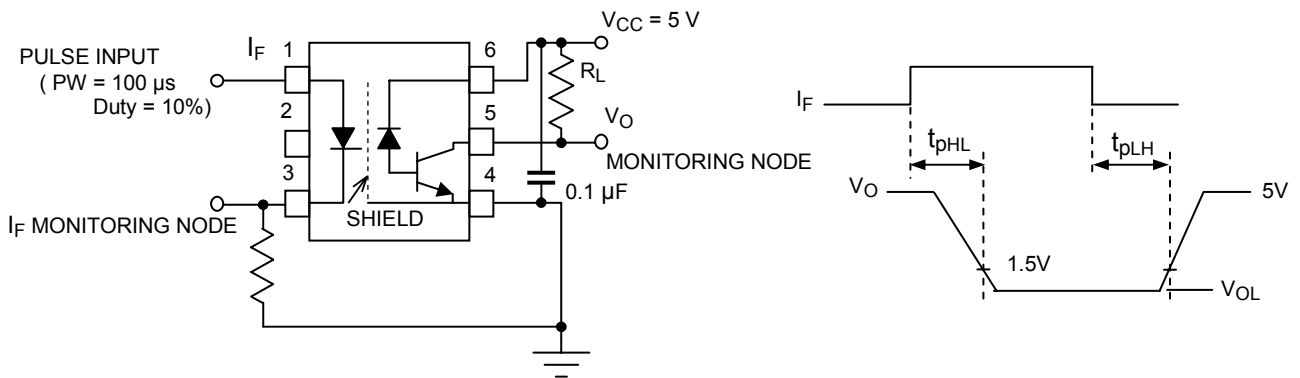
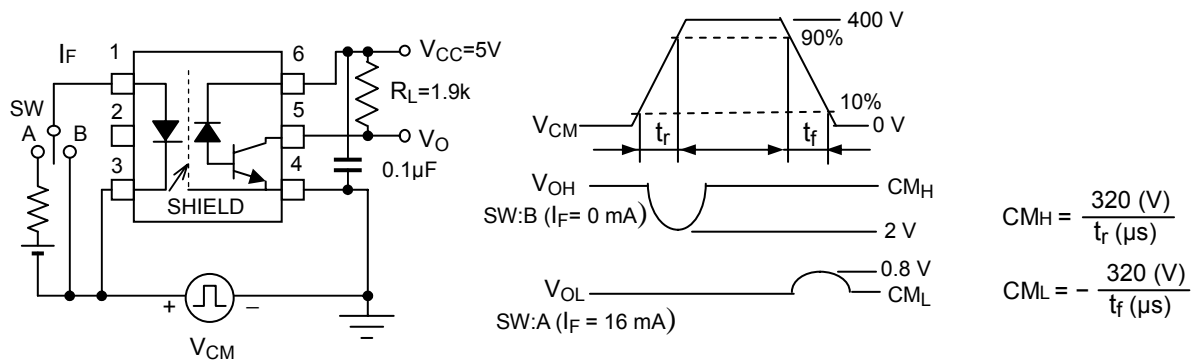
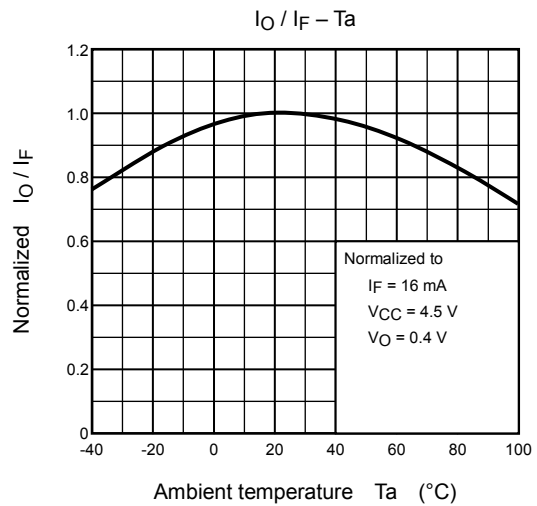
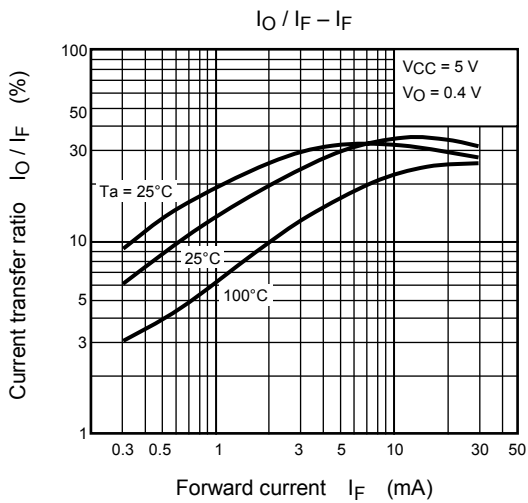
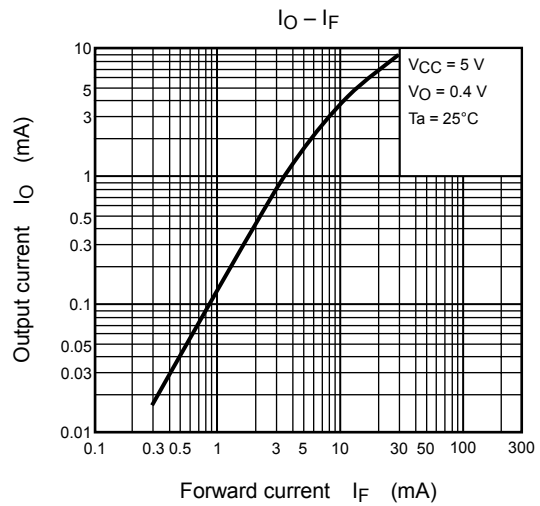
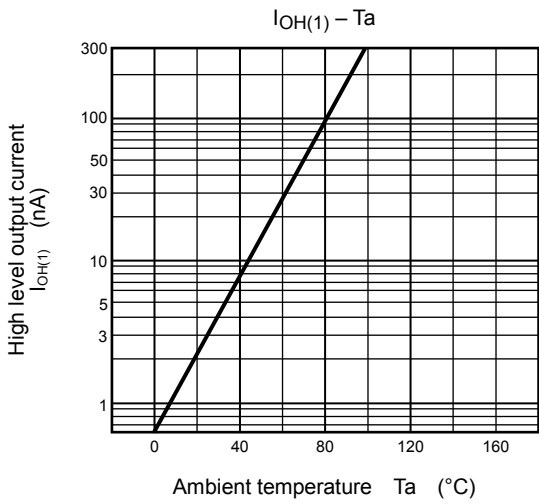
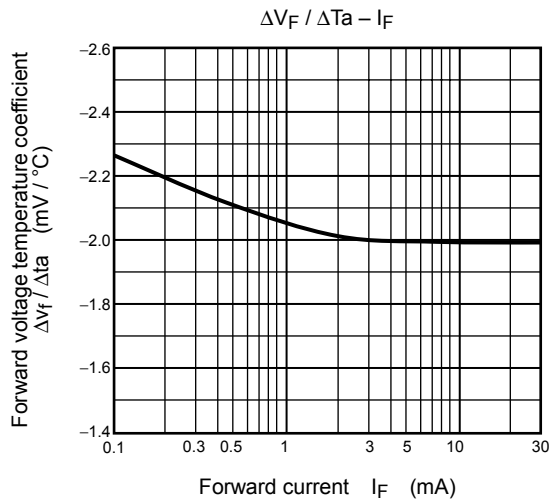
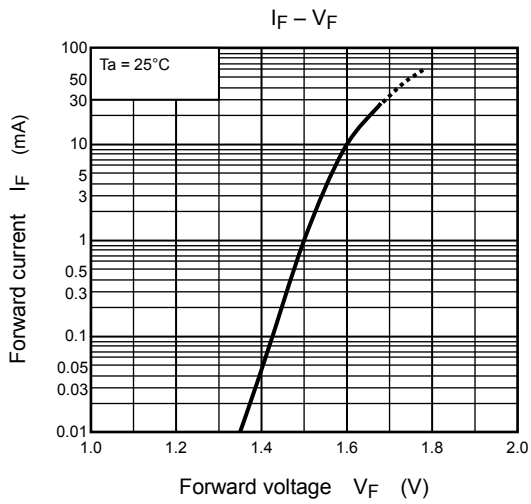
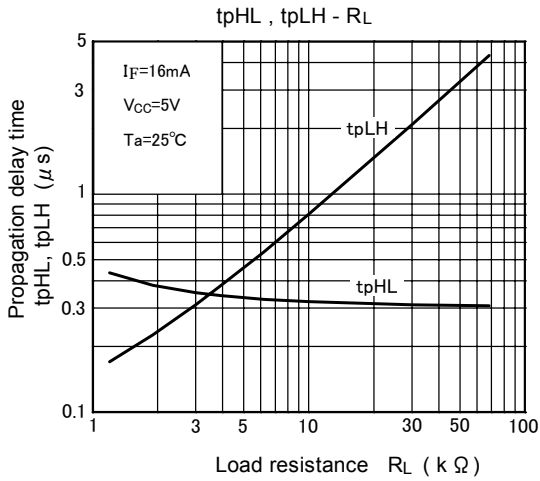
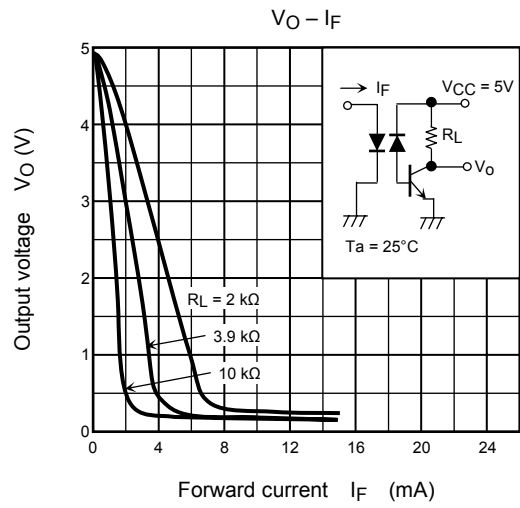
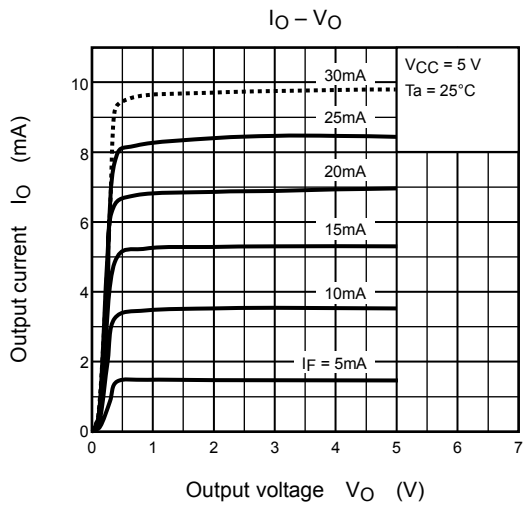

Figure 2. Common Mode Noise Immunity Test Circuit.







RESTRICTIONS ON PRODUCT USE

030619EBC

- The information contained herein is subject to change without notice.
- The information contained herein is presented only as a guide for the applications of our products. No responsibility is assumed by TOSHIBA for any infringements of patents or other rights of the third parties which may result from its use. No license is granted by implication or otherwise under any patent or patent rights of TOSHIBA or others.
- TOSHIBA is continually working to improve the quality and reliability of its products. Nevertheless, semiconductor devices in general can malfunction or fail due to their inherent electrical sensitivity and vulnerability to physical stress. It is the responsibility of the buyer, when utilizing TOSHIBA products, to comply with the standards of safety in making a safe design for the entire system, and to avoid situations in which a malfunction or failure of such TOSHIBA products could cause loss of human life, bodily injury or damage to property.
In developing your designs, please ensure that TOSHIBA products are used within specified operating ranges as set forth in the most recent TOSHIBA products specifications. Also, please keep in mind the precautions and conditions set forth in the "Handling Guide for Semiconductor Devices," or "TOSHIBA Semiconductor Reliability Handbook" etc..
- The TOSHIBA products listed in this document are intended for usage in general electronics applications (computer, personal equipment, office equipment, measuring equipment, industrial robotics, domestic appliances, etc.). These TOSHIBA products are neither intended nor warranted for usage in equipment that requires extraordinarily high quality and/or reliability or a malfunction or failure of which may cause loss of human life or bodily injury ("Unintended Usage"). Unintended Usage include atomic energy control instruments, airplane or spaceship instruments, transportation instruments, traffic signal instruments, combustion control instruments, medical instruments, all types of safety devices, etc.. Unintended Usage of TOSHIBA products listed in this document shall be made at the customer's own risk.
- The products described in this document are subject to the foreign exchange and foreign trade laws.
- TOSHIBA products should not be embedded to the downstream products which are prohibited to be produced and sold, under any law and regulations.
- GaAs(Gallium Arsenide) is used in this product. The dust or vapor is harmful to the human body. Do not break, cut, crush or dissolve chemically.