

## TC94A54MFG/TC94A60MFG Single-chip CD-MP3 Solution

### Highlights

- Highly integrated solution with CD servo, RF amp, 1 Mbit SRAM, decoder and DA converter in a single SiP solution
- Expanding decoder firmware library including MP3, WMA, AAC, ATRAC CD, graphic equalization and surround field effects
- Macro commands simplify software programming
- Programmable RAM and pin-compatible ROM solutions enable customization and design flexibility

### Description

TC94A54MFG and TC94A60MFG are highly integrated, high-performance CD-MP3 solutions that enable playback of CD and multiple compressed audio formats from a single chip. Featuring high-quality audio output in I<sup>2</sup>S, S/PDIF or analog stereo formats, the TC94A54MFG and TC94A60MFG integrate a CD servo, RF amplifier, compressed audio decoder and DA converter in a single system-in-package (SiP) solution. TC94A54MFG

and TC94A60MFG are available in pin-compatible standard ROM versions that can be customized to specific customer requirements using programmable RAM. An extensive decoder firmware library is available for custom ROM versions. TC94A54MFG and TC94A60MFG are ideal for compressed audio CD players where low cost, design flexibility, and high-performance playback and tag/file management are key customer requirements.

### Block Diagram

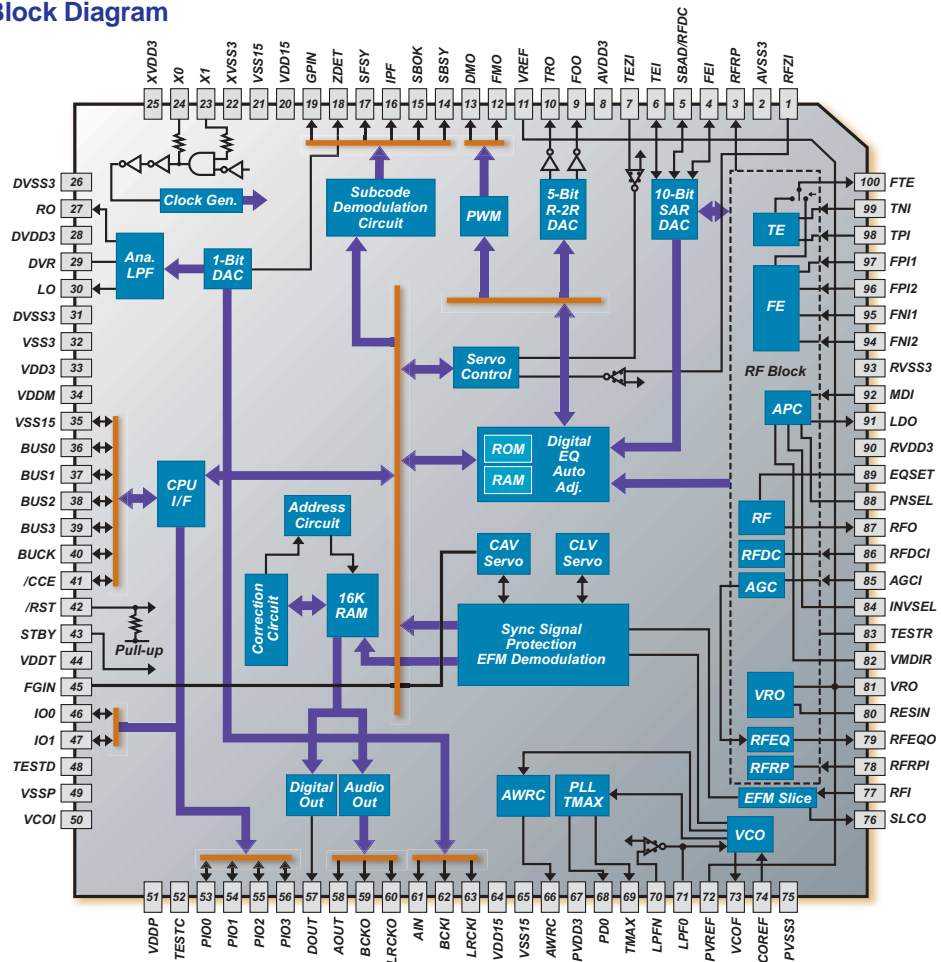

[www.Toshiba.com/taec](http://www.Toshiba.com/taec)

TC94A54MFG/TC94A60MFG Single-chip  
CD-MP3 Solution

**TOSHIBA**  
TOSHIBA AMERICA ELECTRONICS COMPONENTS, INC.

# Product Brief

## TAEC Regional Sales Offices

### NORTHWEST

#### San Jose, CA

TEL: (408) 526-2400

FAX: (408) 526-8910

#### Beaverton, OR

TEL: (503) 466-3721

FAX: (503) 629-0827

### SOUTHWEST

#### Irvine, CA

TEL: (949) 623-2900

FAX: (949) 474-1330

#### Richardson, TX

TEL: (972) 480-0470

FAX: (972) 235-4114

### CENTRAL

#### Buffalo Grove, IL

TEL: (847) 484-2400

FAX: (847) 541-7287

### NORTHEAST

#### Marlboro, MA

TEL: (508) 481-0034

FAX: (508) 481-8828

#### Parsippany, NJ

TEL: (973) 541-4715

FAX: (732) 541-4716

### SOUTHEAST

#### Duluth, GA

TEL: (770) 931-3363

FAX: (770) 931-7602

[www.Toshiba.com/taec](http://www.Toshiba.com/taec)

## Key Features

- CD servo and RF head amplifier with built-in DA converter
- Compressed audio decoder
- Extensive decoder firmware library including MP3, WMA, AAC, ATRAC CD, graphic equalization and surround field algorithms
- Capable of CD text data decoding
- Supports CD-DA and CD-R/RW
- Standard ROM and customized ROM versions available
- 1 Mbit SRAM for error correction and tag/file management
- Programmable RAM for software customization
- Standby function for data storage in 1Mbit SRAM
- I<sup>2</sup>S or S/PDIF output available for external DA converter
- 4-bit parallel CPU interface
- Power requirements: 3.3V and 1.5V
- Lead-free, pin-compatible LQFP100 packages

## Supported Product Families

- TC94A54MFG-001, MP3 and WMA9 decoder firmware
- TC94A54MFG-002, MP3, WMA9, and AAC decoder firmware
- TC94A60MFG-301, MP3 and ATRAC CD decoder firmware

\* The information contained herein is subject to change without notice.

\* The information contained herein is presented only as a guide for the applications of our products. No responsibility is assumed by TOSHIBA for any infringements of patents or other rights of the third parties which may result from its use. No license is granted by implication or otherwise under any patent or patent rights of TOSHIBA or others.

\* TOSHIBA is continually working to improve the quality and reliability of its products. Nevertheless, semiconductor devices in general can malfunction or fail due to their inherent electrical sensitivity and vulnerability to physical stress. It is the responsibility of the buyer, when utilizing TOSHIBA products, to comply with the standards of safety in making a safe design for the entire system, and to avoid situation in which a malfunction or failure of such TOSHIBA products could cause loss of human life, bodily injury or damage to property. In developing your designs, please ensure that TOSHIBA products are used within specified operating ranges as set forth in the most recent TOSHIBA products specifications. Also, please keep in mind the precautions and conditions set forth in the "Handling Guide for Semiconductor Devices," or "TOSHIBA Semiconductor Reliability Handbook" etc.

\* The Toshiba products listed in this document are intended for usage in general electronics applications (computer, personal equipment, office equipment, measuring equipment, industrial robotics, domestic appliances, etc.). These Toshiba products are neither intended nor warranted for usage in equipment that requires extraordinarily high quality and/or reliability or a malfunction or failure of which may cause loss of human life or bodily injury ("Unintended Usage"). Unintended Usage include atomic energy control instruments, airplane or spaceship instruments, transportation instruments, traffic signal instruments, combustion control instruments, medical instruments, all types of safety devices, etc. Unintended Usage of Toshiba products listed in this document shall be made at the customer's own risk.

\* The products described in this document may include products subject to foreign exchange and foreign trade laws.

\* The products contained herein may also be controlled under the U.S. Export Administration Regulations and/or subject to the approval of the U.S. Department of Commerce or U.S. Department of State prior to export. Any export or re-export, directly or indirectly in contravention of any of the applicable export laws and regulations, is hereby prohibited.

**TOSHIBA**  
TOSHIBA AMERICA ELECTRONICS COMPONENTS, INC.

**TC94A54MFG/TC94A60MFG Single-chip  
CD-MP3 Solution**

All trademarks are of their respective manufacturer and may be registered in certain jurisdictions.

© Copyright 2/2005 TAEC