

TMPR4955BFG/CFG, TMPR4956CXBG (TX4955/TX4956) 64-Bit RISC Processor

Highlights

- SysAD bus support
- High-performance, 400 MHz frequency
- Low-power consumption of only 0.3 watts at maximum frequency (internal)
- Low-power consumption of only 0.5W at 400 MHz

Description

The TX4955/TX4956 is a 64-bit RISC (Reduced Instruction Set Computer) microprocessor that is a low-cost, low-power microprocessor developed for interactive consumer applications including set-top terminals, LBP (Laser Beam Printer), and video games.

Features

- True 64-bit microprocessor with TX49/H3 core (BFG), TX49/H4 core (CFG/CXBG)
- Optimized 5-stage pipeline
- 32-bit system address/data bus (TX4955); 64-bit/32-bit system address/data bus (TX4956)
- 32-bit physical address space and 64-bit virtual address space
- SysAD bus interface with R5000 or R4300 compatible protocol (TX4955)
- SysAD bus interface with R5000 or R4300 compatible protocol (TX4956)
- On-chip 32-Kbyte instruction cache and 32-Kbyte data cache
- Low-power consumption

- BFG: (typ. 0.375W – internal)
- 3.3V/1.5V dual power supply
- I/O: 3.3V
- Internal: 1.5V
- CFG/CXBG: (typ. 0.3W – internal)
- 3.3V or 2.5V/1.2V dual power supply
- I/O: 3.3V or 2.5V
- Internal: 1.2V
- Reduced power mode (halt)

- Data cache prefetching
- Memory management unit
 - Contains 48-double entry JTLB, 2-entry instruction TLB, and 4-entry data TLB
- Software compatibility with all MIPS processors
 - MIPS I, II, and III Instruction Set Architecture (ISA)
- EJTAG (Enhanced JTAG) debug support
- Maximum operating frequency
 - Internal: 200/300/333 MHz (BFG), 350/400/450 (CFG/CXBG)
 - External: 133 MHz (200 MHz version: 100 MHz)
- Package:
 - 160-pin QFP (28 mm x 28 mm, 0.65 pitch): TX4955 (BFG/CFG)
 - 217-pin PFBGA (13 mm x 13 mm, 0.8 pitch): TX4956 (CXBG)

Block Diagram

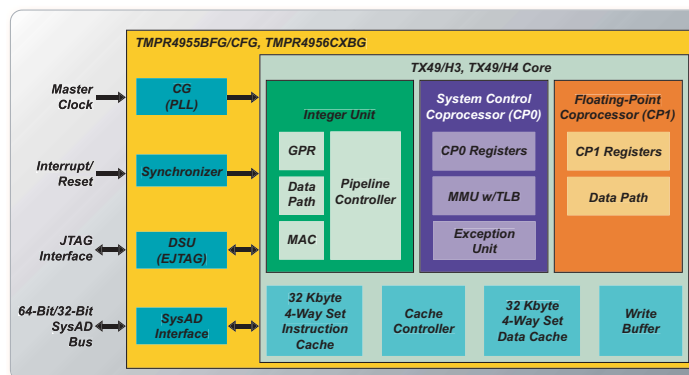

www.Toshiba.com/taec

TMPR4955BFG/CFG, TMPR4956CXBG (TX4955/TX4956)
64-Bit RISC Processor

TOSHIBA
TOSHIBA AMERICA ELECTRONICS COMPONENTS, INC.

Product Brief

TAEC Regional Sales Offices

NORTHWEST

San Jose, CA

TEL: (408) 526-2400
FAX: (408) 526-8910

Portland, OR

TEL: (503) 446-3721
FAX: (503) 629-0827

SOUTHWEST

Irvine, CA

TEL: (949) 455-2000
FAX: (949) 707-5576

Richardson, TX

TEL: (972) 480-0470
FAX: (972) 235-4114

CENTRAL

Deerfield, IL

TEL: (847) 945-1500
FAX: (847) 945-2902

NORTHEAST

Wakefield, MA

TEL: (781) 224-0074
FAX: (781) 224-1095

Edison, NJ

TEL: (732) 248-8070
FAX: (732) 248-8030

SOUTHEAST

Duluth, GA

TEL: (770) 931-3363
FAX: (770) 931-7602

www.Toshiba.com/taec

TX4955CFG Reference Board Block Diagram

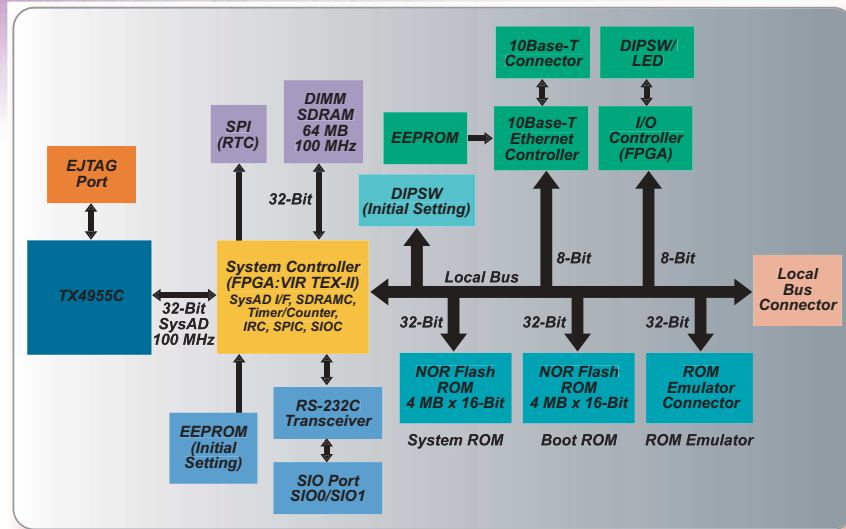

TX System RISC Development Tools

Product Name: TMPR4955BFG/CFG

Reference Boards:

Main Ref. Board—RBHMA4100/BF/In Development

Operating Systems:

Wind River—VxWorks—Yes/In Development
Monta Vista—Linux—In Development

Development Tools:

Green Hills—MULTI 2000 Compiler & Debugger
Red Hat—GNU Pro Compiler & GDB Debugger
Wind River—VisionICE II Emulator with Debugger
YDC (Yokogawa) AdvicePlus Emulator with Debugger
Macraigor TX49 Emulator

* The information contained herein is subject to change without notice.

* The information contained herein is presented only as a guide for the applications of our products. No responsibility is assumed by TOSHIBA for any infringements of patents or other rights of the third parties which may result from its use. No license is granted by implication or otherwise under any patent or patent rights of TOSHIBA or others.

* TOSHIBA is continually working to improve the quality and reliability of its products. Nevertheless, semiconductor devices in general can malfunction or fail due to their inherent electrical sensitivity and vulnerability to physical stress. It is the responsibility of the buyer, when utilizing TOSHIBA products, to comply with the standards of safety in making a safe design for the entire system, and to avoid situation in which a malfunction or failure of such TOSHIBA products could cause loss of human life, bodily injury or damage to property. In developing your designs, please ensure that TOSHIBA products are used within specified operating ranges as set forth in the most recent TOSHIBA products specifications. Also, please keep in mind the precautions and conditions set forth in the "Handling Guide for Semiconductor Devices," or "TOSHIBA Semiconductor Reliability Handbook" etc.

* The Toshiba products listed in this document are intended for usage in general electronics applications (computer, personal equipment, office equipment, measuring equipment, industrial robotics, domestic appliances, etc.). These Toshiba products are neither intended nor warranted for usage in equipment that requires extraordinarily high quality and/or reliability or a malfunction or failure of which may cause loss of human life or bodily injury ("Unintended Usage"). Unintended Usage include atomic energy control instruments, airplane or spaceship instruments, transportation instruments, traffic signal instruments, combustion control instruments, medical instruments, all types of safety devices, etc. Unintended Usage of Toshiba products listed in this document shall be made at the customer's own risk.

* The products described in this document may include products subject to foreign exchange and foreign trade laws.

* The products contained herein may also be controlled under the U.S. Export Administration Regulations and/or subject to the approval of the U.S. Department of Commerce or U.S. Department of State prior to export. Any export or re-export, directly or indirectly in contravention of any of the applicable export laws and regulations, is hereby prohibited.

TOSHIBA
TOSHIBA AMERICA ELECTRONICS COMPONENTS, INC.

TMPR4955BFG/CFG, TMPR4956CXBG (TX4955/TX4956)
64-Bit RISC Processor

All trademarks are of their respective manufacturer and may be registered in certain jurisdictions.

© Copyright 12/2003 TAEC