

TC94A70FG/TC94A73MFG Single-chip CD-MP3 Processor

Highlights

- Highly integrated solution with CD servo, RF amp, 1 Mbit SRAM, multi-bit DA converter and audio DSP with firmware library including MP3, WMA, ATRAC CD, AAC, graphic equalization, and popular surround sound formats
- Pin compatibility between monolithic TC94A70FG and system-in-package (SiP) TC94A73MFG with 16 Mbit DRAM enables a single hardware design to support standard and electronic shock protection (ESP) CD playback versions
- Macro commands simplify software programming
- Programmable RAM and pin-compatible ROM solutions enable customization and reduced time to market.

Description

TC94A70FG and TC94A73MFG are highly integrated, high-performance CD-MP3 solutions that enable playback of CD and multiple compressed audio formats from a single chip. Featuring high-quality audio output in I²S, S/PDIF or analog stereo formats, the TC94A70FG integrates an RF amplifier, CD servo, audio DSP, 1 Mbit SRAM, and a multi-bit DA converter in a CMOS monolithic IC. To the TC94A70FG feature set, the TC94A73MFG adds electronic shock protection (ESP) with DSP firmware and 16 Mbit DRAM in an SiP solution. TC94A70FG and TC94A73MFG are available in standard ROM versions or can also be customized to specific customer requirements using an extensive and growing DSP firmware library including MP3, WMA, ATRAC CD, AAC, graphic equalization and popular surround sound formats. Pin compatibility between the monolithic TC94A70FG and the SiP TC94A73MFG minimizes the

engineering investment needed to upgrade TC94A70FG CD playback designs with ESP. New product design is further aided by programmable RAM and macro commands that simplify CD mechanism playback and compressed audio tag and file management. High integration, software customization, and pin-compatible packages make TC94A70FG and TC94A73MFG ideal for compressed audio CD players where low cost, feature flexibility and time to market are key selection criteria.

Supported Product Families

- TC94A70FG-002: MP3, WMA9 and ATRAC CD DSP firmware
- TC94A70FG-005: MP3, WMA9, ATRAC CD and AAC DSP firmware
- TC94A73MFG-201: MP3, WMA9 and ESP DSP firmware
- TC94A73MFG-202: MP3, WMA9, ATRAC CD, AAC and ESP DSP firmware

Block Diagram

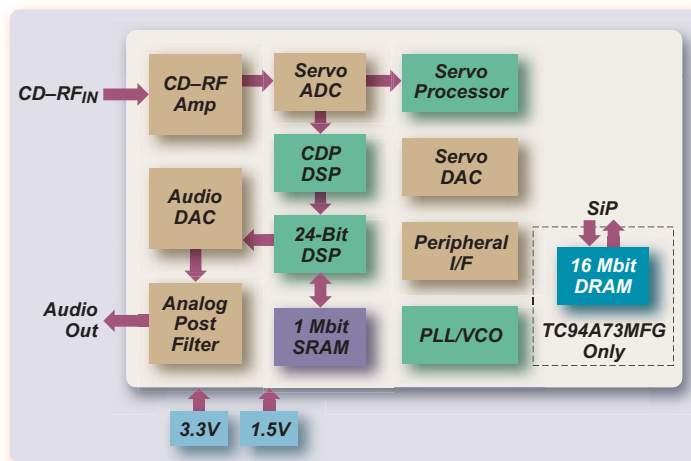

Product Brief

TAEC Regional Sales Offices

NORTHWEST

San Jose, CA

TEL: (408) 526-2400

FAX: (408) 526-2410

Portland, OR

TEL: (503) 784-8879

FAX: (503) 466-9729

SOUTHWEST

Irvine, CA

TEL: (949) 623-2900

FAX: (949) 474-1330

Richardson, TX

TEL: (972) 480-0470

FAX: (972) 235-4114

CENTRAL

Buffalo Grove, IL

TEL: (847) 484-2400

FAX: (847) 541-7287

NORTHEAST

Marlboro, MA

TEL: (508) 481-0034

FAX: (508) 481-8828

Parsippany, NJ

TEL: (973) 541-4715

FAX: (973) 541-4716

SOUTHEAST

Duluth, GA

TEL: (770) 931-3363

FAX: (770) 931-7602

www.Toshiba.com/taec

Features

- CD servo and RF head amplifier
- Multi-bit DA converter with 8x over-sampling digital filter
- Audio DSP for compressed audio decoding
- Extensive DSP firmware library including MP3, WMA, ATRAC CD, AAC, graphic equalization and various surround sound formats
- 16 Mbit DRAM and DSP firmware for ESP (TC94A73MFG only)
- Capable of CD TEXT data decoding (mode 4)
- Supports CD-DA and CD-R/RW (up to 4x speed)
- Standard ROM and customized ROM versions available
- Programmable RAM for software customization
- 1 Mbit SRAM for data buffering and file management
- Low current (10 μ A max) standby mode for data storage
- Digital audio interfaces: (1) I²S input and (1) S/PDIF and (3) I²S outputs
- 4-bit parallel (6 lines) and serial (4 lines) CPU interfaces
- Power requirements: 3.3V and 1.5V
- Lead(Pb)-free, pin-compatible LQFP100 packages

* The information contained herein is subject to change without notice.

* The information contained herein is presented only as a guide for the applications of our products. No responsibility is assumed by TOSHIBA for any infringements of patents or other rights of the third parties which may result from its use. No license is granted by implication or otherwise under any patent or patent rights of TOSHIBA or others.

* TOSHIBA is continually working to improve the quality and reliability of its products. Nevertheless, semiconductor devices in general can malfunction or fail due to their inherent electrical sensitivity and vulnerability to physical stress. It is the responsibility of the buyer, when utilizing TOSHIBA products, to comply with the standards of safety in making a safe design for the entire system, and to avoid situation in which a malfunction or failure of such TOSHIBA products could cause loss of human life, bodily injury or damage to property. In developing your designs, please ensure that TOSHIBA products are used within specified operating ranges as set forth in the most recent TOSHIBA products specifications. Also, please keep in mind the precautions and conditions set forth in the "Handling Guide for Semiconductor Devices," or "TOSHIBA Semiconductor Reliability Handbook" etc.

* The Toshiba products listed in this document are intended for usage in general electronics applications (computer, personal equipment, office equipment, measuring equipment, industrial robotics, domestic appliances, etc.). These Toshiba products are neither intended nor warranted for usage in equipment that requires extraordinarily high quality and/or reliability or a malfunction or failure of which may cause loss of human life or bodily injury ("Unintended Usage"). Unintended Usage include atomic energy control instruments, airplane or spaceship instruments, transportation instruments, traffic signal instruments, combustion control instruments, medical instruments, all types of safety devices, etc. Unintended Usage of Toshiba products listed in this document shall be made at the customer's own risk.

* The products described in this document may include products subject to foreign exchange and foreign trade laws.

* The products contained herein may also be controlled under the U.S. Export Administration Regulations and/or subject to the approval of the U.S. Department of Commerce or U.S. Department of State prior to export. Any export or re-export, directly or indirectly in contravention of any of the applicable export laws and regulations, is hereby prohibited.

TOSHIBA

TC94A70FG/TC94A73MFG Single-chip CD-MP3 Processor