

TMPR4938XB-300/333 (TX4938) 64-bit RISC Processor

Highlights

- 32-bit/66 MHz PCIC Rev 2.2 supports up to 4 PCI devices
- NAND flash controller with IPL (Initial Program Loader)
- 2 Ethernet MACs
- High system performance and low-power consumption of 1.5W at 333 MHz
- Package: 484-pin PBGA

Description

The TX4938 MIPS RISC microprocessor is a highly integrated ASSP solution based on the Toshiba TX49/H3 processor core, a 64-bit MIPS I, II, III Instruction Set Architecture (ISA) compatible with additional instructions. The TX4938 has as peripheral functions an external bus controller, an SDRAM controller, a NAND flash controller, a PCI controller, a DMA controller, an interrupt controller, an AC-link controller, serial and parallel ports, a timer/counter and peripheral circuits such as Ethernet MAC.

Features

- TX49/H3 core (on-chip IEEE754 compliant single/double precision FPU)
- SDRAM controller (4 channels: 64-bit/133 MHz)
- NAND flash memory controller

- External bus controller (8 channels)
- 32-bit PCI controller (33 MHz/66 MHz)
- Direct memory access controller: 8 channels (4 channels are dedicated to AC-link controller)
- Serial I/O port (2 channels)
- Parallel I/O port (maximum 16-bits)
- Synchronous serial interface
- Timer/counter (3 channels)
- AC-link controller (AC97 interface)
- Ethernet MAC (2 channels)
- On-chip ROM for program loader
- On-chip SRAM (2 KB)
- Low-power consumption (typ. 1.5W)
 - Internal: 1.5V
 - I/O: 3.3V
 - Reduced power mode (halt)
- CPU maximum operating frequency: 300 MHz/333 MHz
- IEEE1149.1 (JTAG) support: debugging support unit
- Package: 484-pin PBGA
64 pins are thermal ball for heat dissipation

Block Diagram

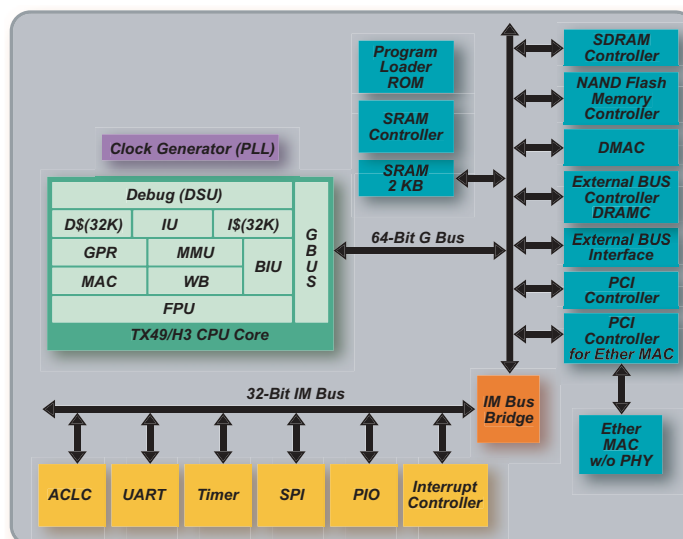

www.Toshiba.com/taec

Product Brief

TAEC Regional Sales Offices

NORTHWEST

San Jose, CA

TEL: (408) 526-2400
FAX: (408) 526-8910

Portland, OR

TEL: (503) 446-3721
FAX: (503) 629-0827

SOUTHWEST

Irvine, CA

TEL: (949) 455-2000
FAX: (949) 707-5576

Richardson, TX

TEL: (972) 480-0470
FAX: (972) 235-4114

CENTRAL

Deerfield, IL

TEL: (847) 945-1500
FAX: (847) 945-2902

NORTHEAST

Marlboro, MA

TEL: (508) 481-0034
FAX: (508) 481-8828

Edison, NJ

TEL: (732) 248-8070
FAX: (732) 248-8030

SOUTHEAST

Duluth, GA

TEL: (770) 931-3363
FAX: (770) 931-7602

www.Toshiba.com/taec

TX4938XB Reference Board Block Diagram

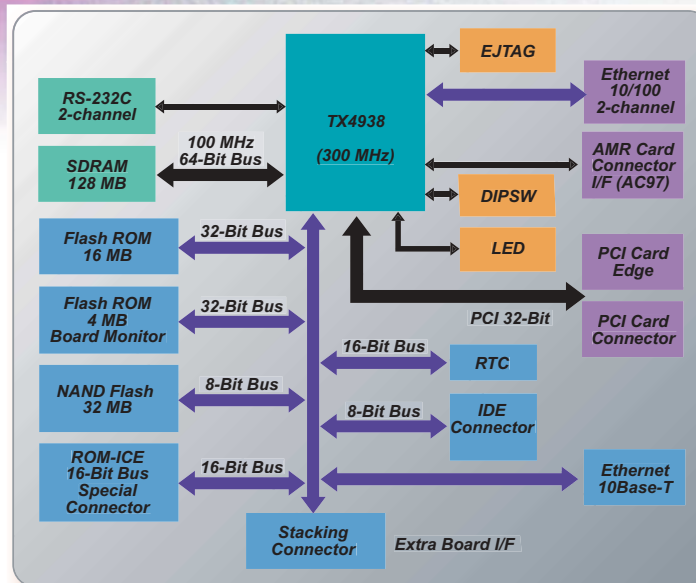

TX System RISC Development Tools

Product Name: TMPR4938XB-300

Reference Boards:

Main Ref. Board—RBHMA4500 (CE)
I/O Daughter Card—RBHIO3100
PCI 3.3 V Backplane—RBHBK4200

Operating Systems:

Wind River—VxWorks
Monta Vista—Linux
Microsoft—Windows CE.NET

Development Tools:

Green Hills—MULTI 2000 Compiler & Debugger
Red Hat—GNU Pro Compiler & GDB Debugger
Wind River—VisionICE II Emulator with Debugger
YDC (Yokogawa) AdvicePlus Emulator with Debugger
Macraigor TX49 Emulator

* The information contained herein is subject to change without notice.

* The information contained herein is presented only as a guide for the applications of our products. No responsibility is assumed by TOSHIBA for any infringements of patents or other rights of the third parties which may result from its use. No license is granted by implication or otherwise under any patent or patent rights of TOSHIBA or others.

* TOSHIBA is continually working to improve the quality and reliability of its products. Nevertheless, semiconductor devices in general can malfunction or fail due to their inherent electrical sensitivity and vulnerability to physical stress. It is the responsibility of the buyer, when utilizing TOSHIBA products, to comply with the standards of safety in making a safe design for the entire system, and to avoid situation in which a malfunction or failure of such TOSHIBA products could cause loss of human life, bodily injury or damage to property. In developing your designs, please ensure that TOSHIBA products are used within specified operating ranges as set forth in the most recent TOSHIBA products specifications. Also, please keep in mind the precautions and conditions set forth in the "Handling Guide for Semiconductor Devices," or "TOSHIBA Semiconductor Reliability Handbook" etc.

* The Toshiba products listed in this document are intended for usage in general electronics applications (computer, personal equipment, office equipment, measuring equipment, industrial robotics, domestic appliances, etc.). These Toshiba products are neither intended nor warranted for usage in equipment that requires extraordinarily high quality and/or reliability or a malfunction or failure of which may cause loss of human life or bodily injury ("Unintended Usage"). Unintended Usage include atomic energy control instruments, airplane or spaceship instruments, transportation instruments, traffic signal instruments, combustion control instruments, medical instruments, all types of safety devices, etc. Unintended Usage of Toshiba products listed in this document shall be made at the customer's own risk.

* The products described in this document may include products subject to foreign exchange and foreign trade laws.

* The products contained herein may also be controlled under the U.S. Export Administration Regulations and/or subject to the approval of the U.S. Department of Commerce or U.S. Department of State prior to export. Any export or re-export, directly or indirectly in contravention of any of the applicable export laws and regulations, is hereby prohibited.

TOSHIBA

TOSHIBA AMERICA ELECTRONICS COMPONENTS, INC.

TMPR4938XB-300/333 (TX4938) 64-bit RISC Processor