

Product Brief

TC90240XBG Frame Rate Converter for 100/120 Hz TVs

Highlights

- Converts 50/60 Hz output to 100/120 Hz output using motion vector estimation and interpolation
- Easy to add to an existing 50/60 Hz TV chassis to create a 100/120 Hz LCD TV
- Supports both WXGA and 1080p LCD panels
- Supports 8-bit and 10-bit LVDS output
- De-judder motion picture material (24 Hz) for a better viewing experience on a 100/120 Hz LCD TV
- Includes picture management functionality – color management, RGB gamma correction, frame rate control dither.
- Easy to integrate into current solution as it requires only minimal I²C programming.
- LVDS input and outputs for easy integration into existing TV chassis

Description

Current high-definition LCD TV panels occasionally show motion blur and judder in some video scenes. To resolve this problem, LCD TV panel makers are building panels that refresh at 100/120 Hz instead of the typical 50/60 Hz. This provides a very sharp picture without the blur associated with LCD TVs. Toshiba's TC90240XBG is designed to take 50/60 Hz input signal, generate additional frames and output the signal at 100/120 Hz. The device uses LVDS inputs and outputs to make it very easy to integrate into an existing LCD TV chassis. In addition, the TC90240XBG provides de-juddering to convert content from 24 Hz to make it appear smooth when displayed at 100/120 Hz. The TC90240XBG also offers picture management functions to improve picture quality.

Features

- Interpolated frame generation using motion estimation and motion compensation
- De-judder of film material
- Picture management
 - Color management
 - RGB gamma correction
 - Frame rate control dither
 - Edge enhancement
- Integrated DDR-2 memory controller
- Input – LVDS 8- or 10-bit WXGA or 1080p signals in RGB, YCbCr or YPbPr format at 50/60 Hz
- Provides RGB to YCbCr function at input signal
- Output – LVDS 8- or 10-bit WXGA or 1080p signals in RGB, YCbCr or YPbPr format at 100/120 Hz
- Provides YCbCr to RGB function at output signal
- I²C programming interface
- Internal PLL for clock generation
- PBGA-564 31mm x 31mm with 1 mm ball pitch
- Built-in memory controller support DDR-2 at 533 MHz data rate

TC90240XBG Frame Rate Converter Block Diagram

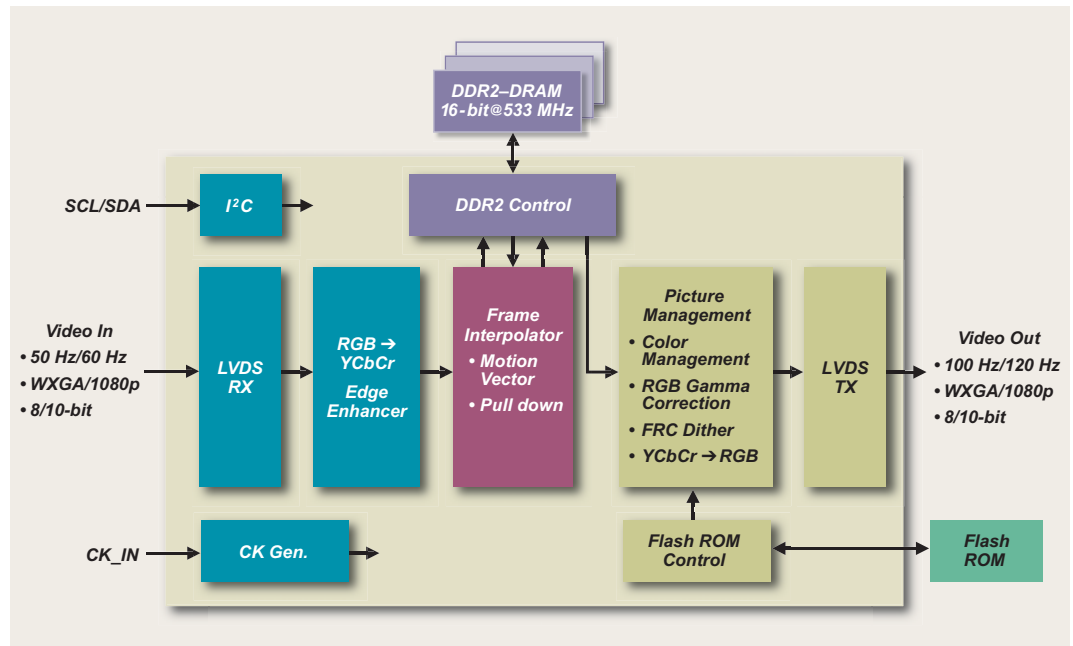

TAEC Regional Sales Offices

NORTHWEST

San Jose, CA

TEL: (408) 526-2400
FAX: (408) 526-2410

Portland, OR

TEL: (503) 784-8879
FAX: (503) 466-9729

SOUTHWEST

Irvine, CA

TEL: (949) 623-2900
FAX: (949) 474-1330

Richardson, TX

TEL: (972) 480-0470
FAX: (972) 235-4114

CENTRAL

Buffalo Grove, IL

TEL: (847) 484-2400
FAX: (847) 541-7287

NORTHEAST

Marlboro, MA

TEL: (508) 481-0034
FAX: (508) 481-8828

Parsippany, NJ

TEL: (973) 541-4715
FAX: (973) 541-4716

SOUTHEAST

Duluth, GA

TEL: (770) 931-3363
FAX: (770) 931-7602

www.Toshiba.com/taec

TC90240XBG System Block Diagram for 120 Hz Full-HD Panel

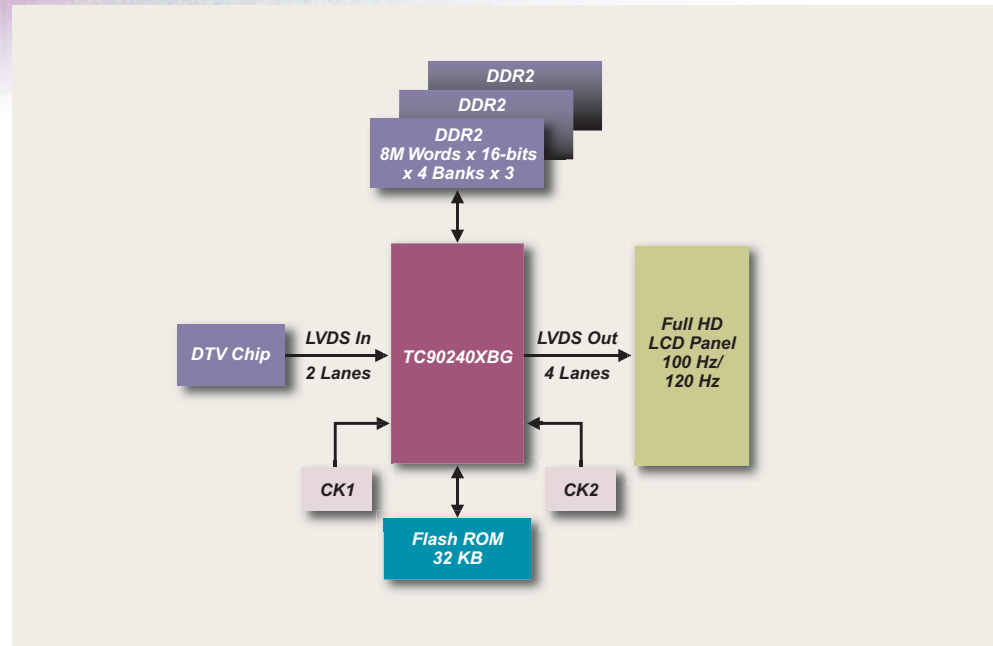

* The information contained herein is subject to change without notice.

* The information contained herein is presented only as a guide for the applications of our products. No responsibility is assumed by TOSHIBA for any infringements of patents or other rights of the third parties which may result from its use. No license is granted by implication or otherwise under any patent or patent rights of TOSHIBA or others.

* TOSHIBA is continually working to improve the quality and reliability of its products. Nevertheless, semiconductor devices in general can malfunction or fail due to their inherent electrical sensitivity and vulnerability to physical stress. It is the responsibility of the buyer, when utilizing TOSHIBA products, to comply with the standards of safety in making a safe design for the entire system, and to avoid situation in which a malfunction or failure of such TOSHIBA products could cause loss of human life, bodily injury or damage to property. In developing your designs, please ensure that TOSHIBA products are used within specified operating ranges as set forth in the most recent TOSHIBA products specifications. Also, please keep in mind the precautions and conditions set forth in the "Handling Guide for Semiconductor Devices," or "TOSHIBA Semiconductor Reliability Handbook" etc.

* The Toshiba products listed in this document are intended for usage in general electronics applications (computer, personal equipment, office equipment, measuring equipment, industrial robotics, domestic appliances, etc.). These Toshiba products are neither intended nor warranted for usage in equipment that requires extraordinarily high quality and/or reliability or a malfunction or failure of which may cause loss of human life or bodily injury ("Unintended Usage"). Unintended Usage include atomic energy control instruments, airplane or spaceship instruments, transportation instruments, traffic signal instruments, combustion control instruments, medical instruments, all types of safety devices, etc. Unintended Usage of Toshiba products listed in this document shall be made at the customer's own risk.

* The products described in this document may include products subject to foreign exchange and foreign trade laws.

* The products contained herein may also be controlled under the U.S. Export Administration Regulations and/or subject to the approval of the U.S. Department of Commerce or U.S. Department of State prior to export. Any export or re-export, directly or indirectly in contravention of any of the applicable export laws and regulations, is hereby prohibited.