

TOSHIBA CMOS Digital Integrated Circuit Silicon Monolithic

# TC4040BP, TC4040BF, TC4040BFN

## TC4040B 12 Stage Ripple-Carry Binary Counter/Dividers

TC4040B is 12 stage ripple carry binary counter having asynchronous clear function. This counter advances its counting stage by falling edge of  $\overline{\text{CLOCK}}$  input. When  $\overline{\text{RESET}}$  input is placed "H", all the circuits are reset regardless of  $\overline{\text{CLOCK}}$  input making all the outputs (Q1 through Q12) to be "L".

This is most suitable for frequency dividers, control circuits and timing circuits.

### Pin Assignment

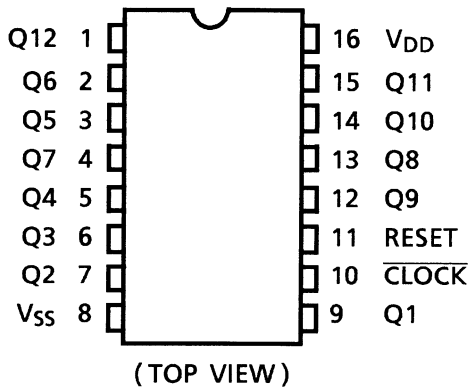

### Truth Table

$\overline{\text{CLOCK}} \Delta$	RESET	Output State
*	H	All Outputs = "L"
	L	No Change
	L	Advance to Next State

$\Delta$ : Level change

\*: Don't care

Note: xxxFN (JEDEC SOP) is not available in Japan.

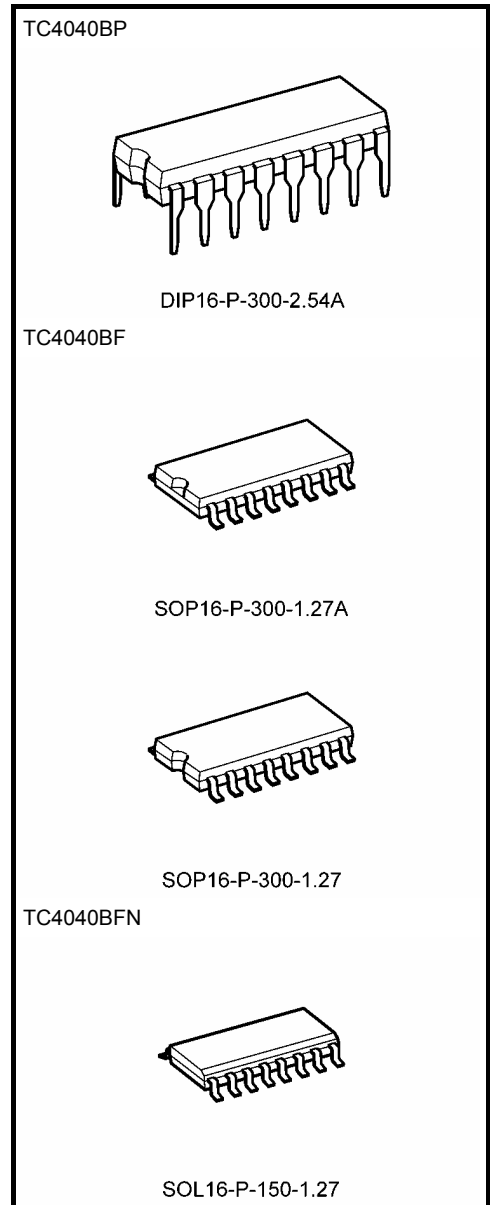

### Weight

DIP16-P-300-2.54A	: 1.00 g (typ.)
SOP16-P-300-1.27A	: 0.18 g (typ.)
SOP16-P-300-1.27	: 0.18 g (typ.)
SOL16-P-150-1.27	: 0.13 g (typ.)

**Logic Diagram**



**Absolute Maximum Ratings (Note)**

Characteristics	Symbol	Rating	Unit
DC supply voltage	$V_{DD}$	$V_{SS} - 0.5$ to $V_{SS} + 20$	V
Input voltage	$V_{IN}$	$V_{SS} - 0.5$ to $V_{DD} + 0.5$	V
Output voltage	$V_{OUT}$	$V_{SS} - 0.5$ to $V_{DD} + 0.5$	V
DC input current	$I_{IN}$	$\pm 10$	mA
Power dissipation	$P_D$	300 (DIP)/180 (SOIC)	mW
Operating temperature range	$T_{opr}$	-40 to 85	$^{\circ}C$
Storage temperature range	$T_{stg}$	-65 to 150	$^{\circ}C$

Note: Exceeding any of the absolute maximum ratings, even briefly, lead to deterioration in IC performance or even destruction.

**Recommended Operating Conditions ( $V_{SS} = 0$  V) (Note)**

Characteristics	Symbol	Test Condition	Min	Typ.	Max	Unit
DC supply voltage	$V_{DD}$	—	3	—	18	V
Input voltage	$V_{IN}$	—	0	—	$V_{DD}$	V

Note: The recommended operating conditions are required to ensure the normal operation of the device. Unused inputs must be tied to either VCC or GND.

## Static Electrical Characteristics (V<sub>SS</sub> = 0 V)

Characteristics	Sym- bol	Test Condition	V <sub>DD</sub> (V)	-40°C		25°C			85°C		Unit	
				Min	Max	Min	Typ.	Max	Min	Max		
High-level output voltage	V <sub>OH</sub>	I <sub>OUT</sub>   < 1 μA V <sub>IN</sub> = V <sub>SS</sub> , V <sub>DD</sub>	5	4.95	—	4.95	5.00	—	4.95	—	V	
			10	9.95	—	9.95	10.00	—	9.95	—		
			15	14.95	—	14.95	15.00	—	14.95	—		
Low-level output voltage	V <sub>OL</sub>	I <sub>OUT</sub>   < 1 μA V <sub>IN</sub> = V <sub>SS</sub> , V <sub>DD</sub>	5	—	0.05	—	0.00	0.05	—	0.05	V	
			10	—	0.05	—	0.00	0.05	—	0.05		
			15	—	0.05	—	0.00	0.05	—	0.05		
Output high current	I <sub>OH</sub>	V <sub>OH</sub> = 4.6 V V <sub>OH</sub> = 2.5 V V <sub>OH</sub> = 9.5 V V <sub>OH</sub> = 13.5 V V <sub>IN</sub> = V <sub>SS</sub> , V <sub>DD</sub>	5	-0.61	—	-0.51	-1.0	—	-0.42	—	mA	
			5	-2.50	—	-2.10	-4.0	—	-1.70	—		
			10	-1.50	—	-1.30	-2.2	—	-1.10	—		
			15	-4.00	—	-3.40	-9.0	—	-2.80	—		
Output low current	I <sub>OL</sub>	V <sub>OL</sub> = 0.4 V V <sub>OL</sub> = 0.5 V V <sub>OL</sub> = 1.5 V V <sub>IN</sub> = V <sub>SS</sub> , V <sub>DD</sub>	5	0.61	—	0.51	1.5	—	0.42	—	mA	
			10	1.50	—	1.30	3.2	—	1.10	—		
			15	4.00	—	3.40	12.0	—	2.80	—		
Input high voltage	V <sub>IH</sub>	V <sub>OUT</sub> = 0.5 V, 4.5 V V <sub>OUT</sub> = 1.0 V, 9.0 V V <sub>OUT</sub> = 1.5 V, 13.5 V  I <sub>OUT</sub>   < 1 μA	5	3.5	—	3.5	2.75	—	3.5	—	V	
			10	7.0	—	7.0	5.50	—	7.0	—		
			15	11.0	—	11.0	8.25	—	11.0	—		
Input low voltage	V <sub>IL</sub>	V <sub>OUT</sub> = 0.5 V, 4.5 V V <sub>OUT</sub> = 1.0 V, 9.0 V V <sub>OUT</sub> = 1.5 V, 13.5 V  I <sub>OUT</sub>   < 1 μA	5	—	1.5	—	2.25	1.5	—	1.5	V	
			10	—	3.0	—	4.50	3.0	—	3.0		
			15	—	4.0	—	6.75	4.0	—	4.0		
Input current	"H" level	I <sub>IH</sub>	V <sub>IH</sub> = 18 V	18	—	0.1	—	10 <sup>-5</sup>	0.1	—	1.0	μA
	"L" level	I <sub>IL</sub>	V <sub>IL</sub> = 0 V	18	—	-0.1	—	-10 <sup>-5</sup>	-0.1	—	-1.0	
Quiescent supply current	I <sub>DD</sub>	V <sub>IN</sub> = V <sub>SS</sub> , V <sub>DD</sub> (Note)	5	—	5	—	0.005	5	—	150	μA	
			10	—	10	—	0.010	10	—	300		
			15	—	20	—	0.015	20	—	600		

Note: All valid input combinations.

## Dynamic Electrical Characteristics (Ta = 25°C, VSS = 0 V, CL = 50 pF)

Characteristics	Symbol	Test Condition	VDD (V)	Min	Typ.	Max	Unit
Output transition time (low to high)	t <sub>TLH</sub>	—	5	—	70	200	ns
			10	—	35	100	
			15	—	30	80	
Output transition time (high to low)	t <sub>THL</sub>	—	5	—	70	200	ns
			10	—	35	100	
			15	—	30	80	
Propagation delay time ( $\overline{\text{CLOCK}}$ - Q1)	t <sub>pLH</sub>	—	5	—	160	360	ns
			10	—	80	160	
			15	—	65	130	
Propagation delay time ( $\overline{\text{CLOCK}}$ - Q1)	t <sub>pHL</sub>	—	5	—	160	360	ns
			10	—	80	160	
			15	—	65	130	
Propagation delay time ( $\overline{\text{CLOCK}}$ - Q12)	t <sub>pLH</sub>	—	5	—	900	1800	ns
			10	—	450	900	
			15	—	360	720	
Propagation delay time ( $\overline{\text{CLOCK}}$ - Q12)	t <sub>pHL</sub>	—	5	—	900	1800	ns
			10	—	450	900	
			15	—	360	720	
Propagation delay time (RESET-Q)	t <sub>pHL</sub>	—	5	—	150	280	ns
			10	—	70	120	
			15	—	50	100	
Max clock frequency	f <sub>CL</sub>	—	5	3.5	10	—	MHz
			10	8.0	20	—	
			15	12.0	25	—	
Min clock pulse width	t <sub>w</sub>	—	5	—	50	140	ns
			10	—	20	60	
			15	—	15	40	
Min pulse width (RESET)	t <sub>w</sub>	—	5	—	100	200	ns
			10	—	40	80	
			15	—	30	60	
Min removal time (RESET - $\overline{\text{CLOCK}}$ )	t <sub>rem</sub>	—	5	—	—	350	ns
			10	—	—	150	
			15	—	—	100	
Max clock input rise time Max clock input fall time	t <sub>rCL</sub> t <sub>fCL</sub>	—	5	No limit			μs
			10				
			15				
Input capacitance	C <sub>IN</sub>	—		—	5	7.5	pF

**Waveforms for Measurement of Dynamic Characteristics**

**Waveform 1**

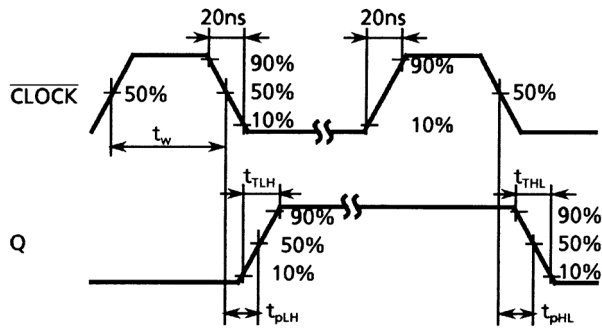

**Waveform 2**

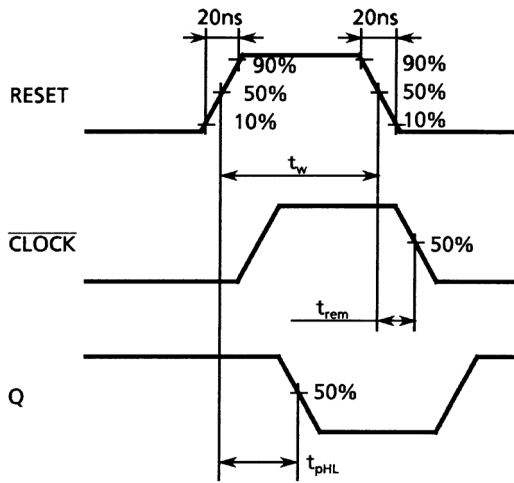

## Package Dimensions

DIP16-P-300-2.54A

Unit : mm

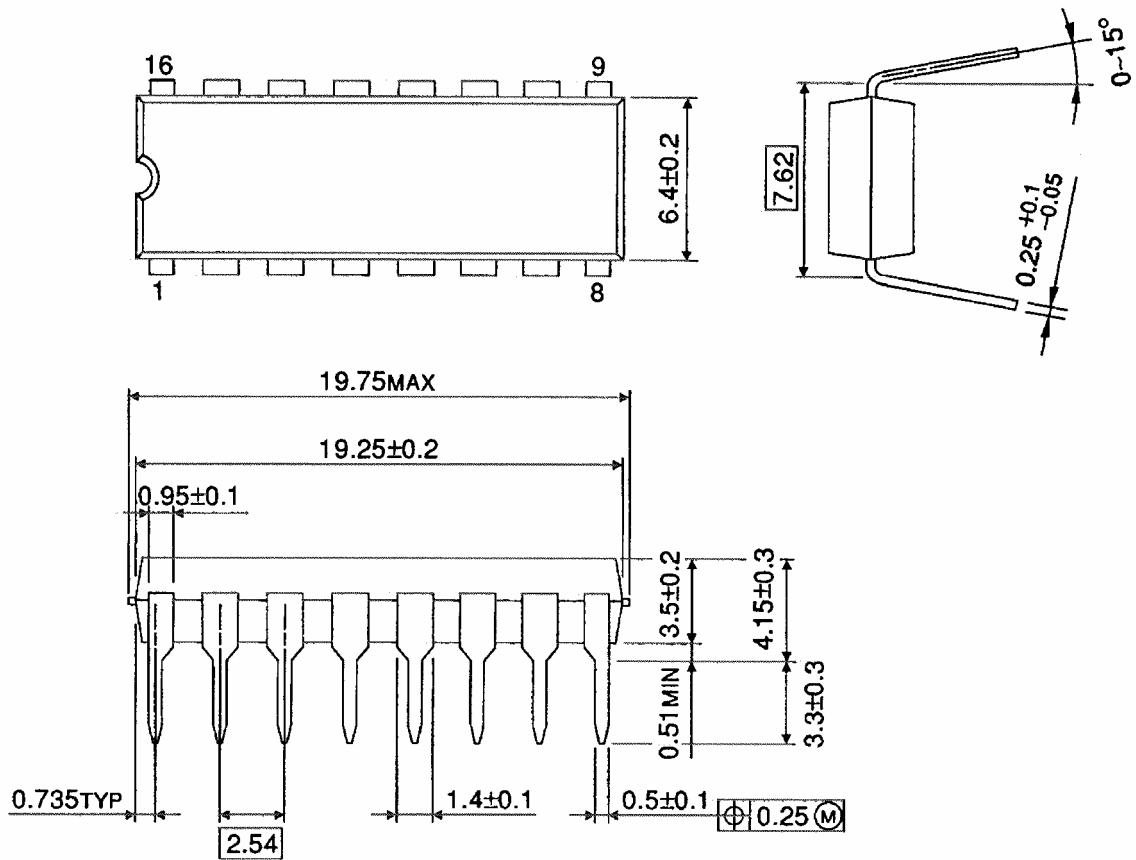

Weight: 1.00 g (typ.)

## Package Dimensions

SOP16-P-300-1.27A

Unit: mm

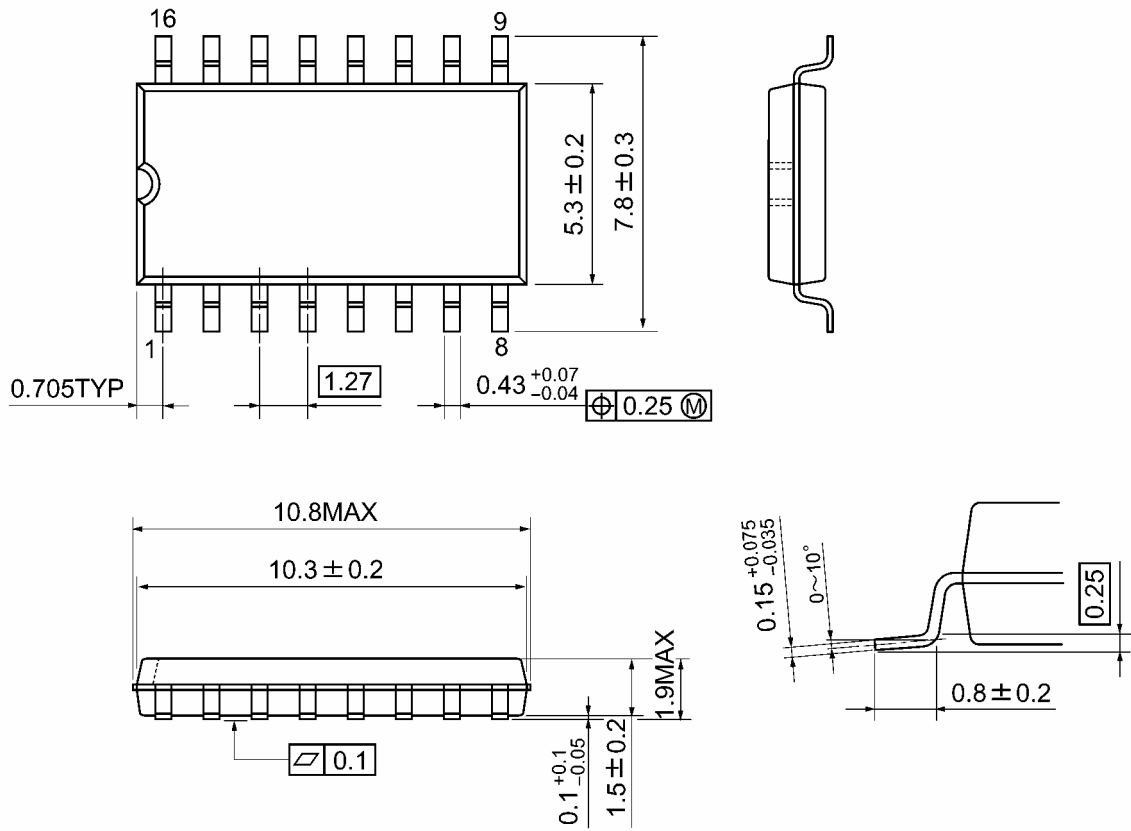

Weight: 0.18 g (typ.)

**Package Dimensions**

SOP16-P-300-1.27

Unit : mm

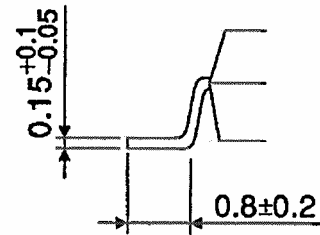
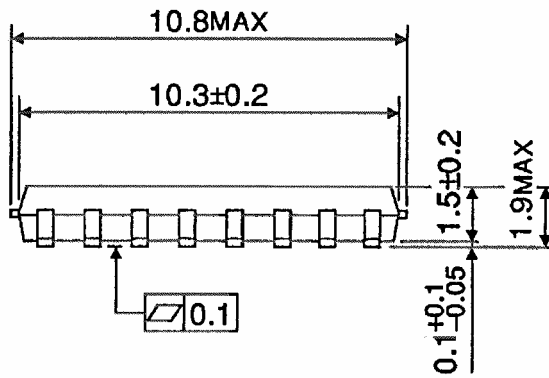
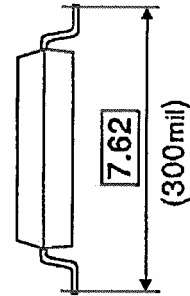
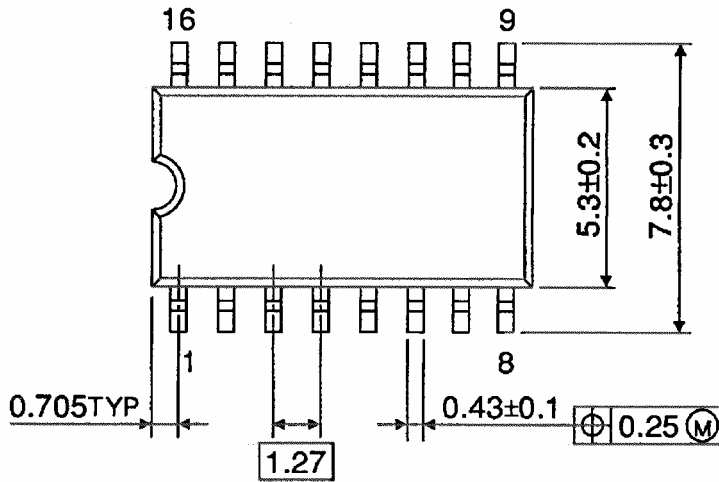

Weight: 0.18 g (typ.)

Package Dimensions (Note)

SOL16-P-150-1.27

Unit : mm

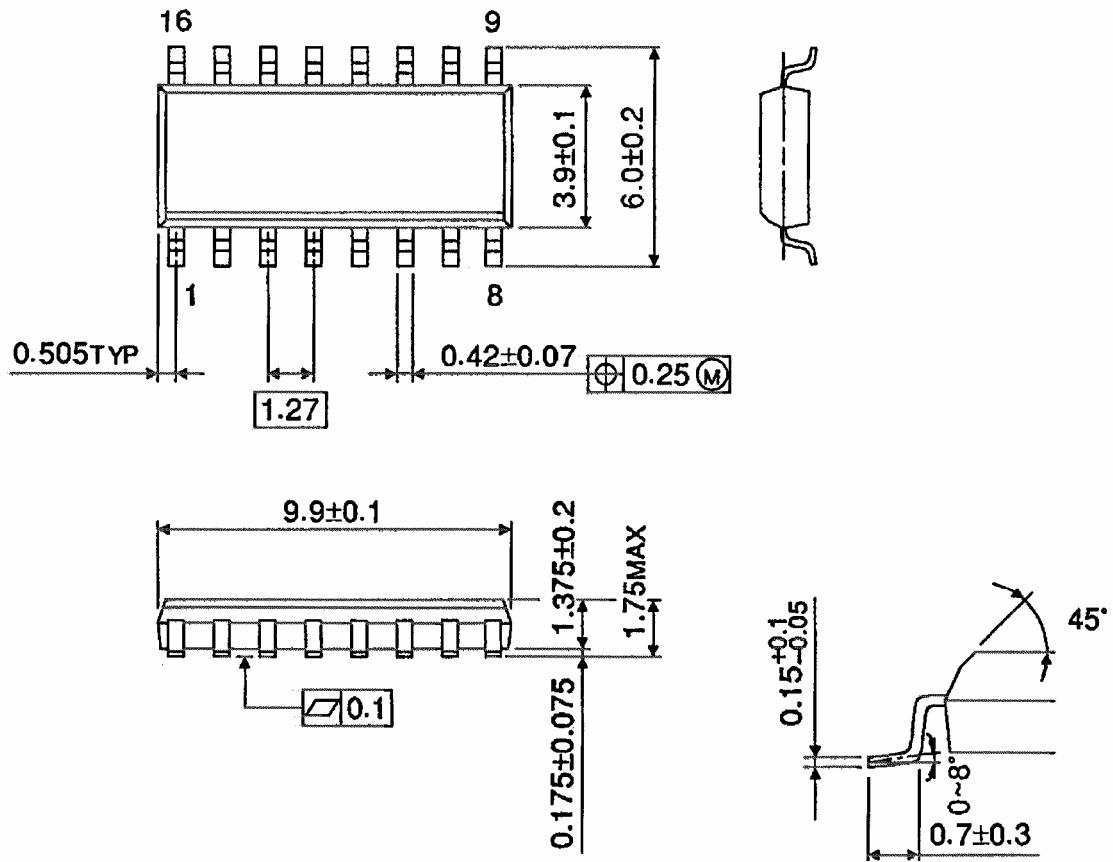

Note: This package is not available in Japan.

Weight: 0.13 g (typ.)

**Note: Lead (Pb)-Free Packages****DIP16-P-300-2.54A SOP16-P-300-1.27A SOL16-P-150-1.27****RESTRICTIONS ON PRODUCT USE**

20070701-EN

- The information contained herein is subject to change without notice.
- TOSHIBA is continually working to improve the quality and reliability of its products. Nevertheless, semiconductor devices in general can malfunction or fail due to their inherent electrical sensitivity and vulnerability to physical stress. It is the responsibility of the buyer, when utilizing TOSHIBA products, to comply with the standards of safety in making a safe design for the entire system, and to avoid situations in which a malfunction or failure of such TOSHIBA products could cause loss of human life, bodily injury or damage to property.  
In developing your designs, please ensure that TOSHIBA products are used within specified operating ranges as set forth in the most recent TOSHIBA products specifications. Also, please keep in mind the precautions and conditions set forth in the "Handling Guide for Semiconductor Devices," or "TOSHIBA Semiconductor Reliability Handbook" etc.
- The TOSHIBA products listed in this document are intended for usage in general electronics applications (computer, personal equipment, office equipment, measuring equipment, industrial robotics, domestic appliances, etc.). These TOSHIBA products are neither intended nor warranted for usage in equipment that requires extraordinarily high quality and/or reliability or a malfunction or failure of which may cause loss of human life or bodily injury ("Unintended Usage"). Unintended Usage include atomic energy control instruments, airplane or spaceship instruments, transportation instruments, traffic signal instruments, combustion control instruments, medical instruments, all types of safety devices, etc.. Unintended Usage of TOSHIBA products listed in this document shall be made at the customer's own risk.
- The products described in this document shall not be used or embedded to any downstream products of which manufacture, use and/or sale are prohibited under any applicable laws and regulations.
- The information contained herein is presented only as a guide for the applications of our products. No responsibility is assumed by TOSHIBA for any infringements of patents or other rights of the third parties which may result from its use. No license is granted by implication or otherwise under any patents or other rights of TOSHIBA or the third parties.
- Please contact your sales representative for product-by-product details in this document regarding RoHS compatibility. Please use these products in this document in compliance with all applicable laws and regulations that regulate the inclusion or use of controlled substances. Toshiba assumes no liability for damage or losses occurring as a result of noncompliance with applicable laws and regulations.