

# TOSHIBA

## INSTRUCTION MANUAL

### 3 CCD CAMERA

# IK-TF9C

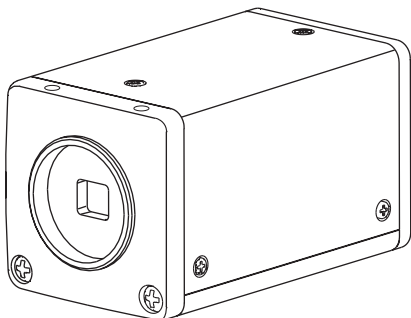

#### For Customer Use

Enter below the Serial # which is located on the bottom of the cabinet. Retain this information for future reference.

Model #: IK-TF9C

Serial #: \_\_\_\_\_

#### FCC NOTICE

This equipment has been tested and found to comply with the limits for a Class A digital device, pursuant to Part 15 of the FCC Rules. These limits are designed to provide reasonable protection against harmful interference when the equipment is operated in a commercial environment. This equipment generates, uses, and can radiate radio frequency energy and, if not installed and used in accordance with the instruction manual, may cause harmful interference to radio communications. Operation of this equipment in a residential area is likely to cause harmful interference in which case the user will be required to correct the interference at his own expense.

**USER-INSTALLER CAUTION:** Your authority to operate this FCC verified equipment could be voided if you make changes or modifications not expressly approved by the party responsible for compliance to Part 15 of the FCC Rules.

This Class A digital apparatus complies with Canadian ICES-003.

Cet appareil numérique de la classe A est conforme à la norme NMB-003 du Canada.

#### Following information is only for EU-member states:

The use of the symbol indicates that this product may not be treated as household waste. By ensuring this product is disposed of correctly, you will help prevent potential negative consequences for the environment and human health, which could otherwise be caused by inappropriate waste handling of this product. For more detailed information about the takeback and recycling of this product, please contact your supplier where you purchased the product or consult.



# SAFETY PRECAUTIONS

## Safety icons

This manual contains safety instructions that must be observed in order to avoid potential hazards that could result in personal injuries, damage to your equipment, or loss of data. These safety cautions have been classified according to the seriousness of the risk, and the icons highlight these instructions as follows:

---

**▲ WARNING** Indicates a potentially hazardous situation which, if not avoided, could result in death or serious injury.

---

---

**▲ CAUTION** Indicates a potentially hazardous situation which, if not avoided, may result in minor or moderate injury.

---

---

**CAUTION** Indicates a potentially hazardous situation which, if not avoided, may result in property damage.

---

---

**▲ WARNING** **Stop operation immediately when any abnormality or defect occurs.**  
Use during an abnormal condition; such as emitting smoke, burning odors, damage from dropping invasion of foreign objects, etc. may cause fire and/or electric shock. Immediately stop the power source and contact your dealer.

---

---

**▲ WARNING** **Avoid installing in a shower room or a bathroom.**  
This may cause fire and/or electric shock.

---

---

**▲ WARNING** **Do not operate in places with possibility of becoming wet.**  
This may cause fire and/or electric shock.

---

---

**▲ WARNING** **Do not repair, disassemble and/or modify by yourself.**  
This may cause fire and/or electric shock. Be always sure to contact your dealer for internal repair, check and cleaning of the product.

---

---

**▲ WARNING** **Use the specified power supply.**  
Otherwise, a fire or an electric shock may occur.

---

---

**▲ WARNING** **Don't place things or materials on the unit.**  
Ingress of foreign materials such as metallic objects and/or liquids into the product may cause a fire or an electric shock.

---

---

**▲ WARNING** **Do not put the product in an unstable, slanting and/or vibrated place.**  
Drop and/or fall of the product may cause serious injury.

---

---

**▲ WARNING** **Do not touch the product and/or any connection cables during a thunderstorm.**  
This might cause electric shock.

---

**CAUTION****Note the following instructions when installing.**

- Do not cover the product by any material.
- Do not put the product on an Inflammable material such as carpet or blanket.
- Do not put the product in a narrow space, since the heat generated from the product may be difficult to emanate.

If you do not follow the above, the heat generated by the product may cause fire.

**CAUTION****Do not put the product in direct sunshine and/or high temperature.**

The temperature inside the product may cause fire.

**▲ CAUTION****Avoid setting in humid, smoky, vaporized or dusty places.**

This may cause fire and/or electric shock.

**▲ CAUTION****Do not point the lens directly at the sun and/or intensive light such as direct sunlight, etc.**

Focusing of the light may cause injury of eye and/or fire.

**CAUTION****Ask your dealer to perform a periodical check and internal cleaning (approx. once every five years).**

Dust inside the product may cause fire and/or trouble. For check and cleaning cost, please consult your dealer.

## Disclaimer

We disclaim any responsibility and shall be held harmless for any damages or losses incurred by the user in any of the following cases:

1. Fire, earthquake or any other act of God; acts by third parties; misuse by the user, whether intentional or accidental; use under extreme operating conditions.
2. Malfunction or non-function resulting in indirect, additional or consequential damages, including but not limited to loss of expected income and suspension of business activities.
3. Incorrect use not in compliance with instructions in this instruction manual.
4. Malfunctions resulting from misconnection to other equipment.
5. Repairs or modifications made by the user or caused to be made by the user and carried out by an unauthorized third party.
6. Notwithstanding the foregoing, Toshiba's liabilities shall not, in any circumstances, exceed the purchase price of the product.

## Limitation of Usage

The product is not designed for any "critical applications." "Critical applications" means life support systems, exhaust or smoke extraction applications, medical applications, commercial aviation, mass transit applications, military applications, homeland security applications, nuclear facilities or systems or any other applications where product failure could lead to injury to persons or loss of life or catastrophic property damage. Accordingly, [Toshiba/TAIS] disclaims any and all liability arising out of the use of the product in any critical applications.

## Protection of Personal Information

Images taken by the camera that reveal the likeness of an individual person may be considered personal information. To disclose, exhibit or transmit those images over the internet or otherwise, consent of the person may be required.

# Copyright and Right of Portrait

There may be a conflict with the Copyright Law and other laws when a customer uses, displays, distributes, or exhibits an image picked up by the camera without permission from the copyright holder. Please also note that transfer of an image or file covered by copyright is restricted to use within the scope permitted by the Copyright Law.

## TABLE OF CONTENTS

<b>1. CAUTIONS ON USE AND INSTALLATION .....</b>	<b>5</b>		
<b>2. COMPONENTS .....</b>	<b>5</b>		
<b>3. NAMES AND FUNCTIONS .....</b>	<b>6</b>		
<b>4. CONNECTION .....</b>	<b>7</b>		
4.1 Standard Connection .....	7		
4.2 Cautions on Connection .....	7		
4.3 Connector Pin Assignments .....	7		
<b>5. OPERATION .....</b>	<b>8</b>		
5.1 White Balance .....	8		
<b>6. ITEMS CONTROLLED BY USING     ON SCREEN DISPLAY .....</b>	<b>10</b>		
<b>7. MODE SETTING BY ON SCREEN DISPLAY ....</b>	<b>11</b>		
7.1 Using the Menus .....	11		
7.2 Menus .....	12		
(1) SHUTTER (Electronic shutter) .....	12		
(1.1) Changing each setting in MANU mode .....	13		
(1.2) Changing each setting in SS (synchro. scan) mode .....	14		
(1.3) Changing each setting in E.TRG mode .....	15		
(1.3.1) Changing each setting in 1P SNR mode .....	15		
(1.3.2) Changing each setting in 1P SR mode .....	16		
(1.3.3) Changing each setting in PW SNR mode .....	17		
(1.3.4) Changing each setting in PW SR mode .....	18		
(2) GAIN (Video gain) .....	19		
(2.1) Changing each setting in GAIN .....	19		
(3) WHT BAL (White balance) .....	20		
(3.1) Changing each setting in AWB (Automatic White Balance) mode ....	20		
(3.2) Changing each setting in MANU (Manual) mode .....	20		
(4) PROCESS .....	21		
(4.1) Changing gamma correction .....	21		
(4.2) Changing master pedestal .....	21		
(4.3) Changing R pedestal .....	21		
(4.4) Changing B pedestal .....	22		
(4.5) Changing the shading correction mode .....	22		
(4.6) Changing the manual shading correction setting .....	22		
(5) OPTION .....	22		
(5.1) Changing serial communication baud rate .....	22		
(6) Setting to factory setting status .....	22		
7.3 Synchro. Scan Operation .....	23		
(1) Setting by 2H .....	23		
(2) Setting by the frame .....	23		
7.4 E. TRG (External trigger) .....	24		
(1) 1P SNR (1 Pulse Trigger Sync Non Reset) .....	24		
(1.1) 1 Pulse Trigger SYNC-NON RESET Picture Output Timing .....	24		
(2) 1P SR (1 Pulse Trigger Sync Reset) .....	25		
(2.1) 1 Pulse Trigger SYNC-RESET Picture Output Timing .....	25		
(3) PW SNR (Pulse width trigger SYNC-NON RESET) .....	26		
(3.1) Pulse Width Trigger SYNC-NON RESET Picture Output Timing .....	26		
(4) PW SR (Pulse width trigger SYNC-RESET) .....	27		
(4.1) 1 Pulse Width Trigger SYNC-RESET Picture Output Timing .....	27		
7.5 Partial Read .....	28		
(1) Partial Scanning OFF (All pixels scanning) .....	28		
(2) Partial Scanning ON .....	28		
(3) When Partial Scanning Mode is ON .....	28		
<b>8. OUTPUT WAVEFORM TIMING CHART .....</b>	<b>29</b>		
(1) Horizontal Output Waveform Timing Chart ...	29		
(2) Vertical Output Waveform Timing Chart ...	29		
<b>9. SPECIFICATIONS .....</b>	<b>30</b>		
<b>10. EXTERNAL APPEARANCE DIAGRAM .....</b>	<b>31</b>		
<b>11. BEFORE MAKING A SERVICE CALL .....</b>	<b>31</b>		

This product is 3CCD color camera with digital video output.

# 1. CAUTIONS ON USE AND INSTALLATION

- **Carefully handle the units.**  
Do not drop, or give a strong shock or vibration to the camera. This may cause problems. Treat the camera cables carefully to prevent cable problems, such as cable breakdown and loosened connections.
- **Do not shoot intense light.**  
If there is an intense light at a location on the screen such as a spot light, a blooming and smearing may occur. When intense light enters, vertical stripes may appear on the screen. This is not a malfunction. Ghosts may occur when there is an intense light near the object. In this case, change the shooting angle.
- **Install the camera in a location free from noise.**  
If the camera or the cables are located near power utility lines or a TV, etc. undesirable noise may appear on the screen. In such a case, try to change the location of the camera or the cable wiring.
- **Moire**  
When thin stripe patterns are shot, stripe patterns that are not actually there (moire) may appear as interference stripes. This is not a malfunction.
- **Operating ambient temperature and humidity.**  
Do not use the camera in places where temperature and humidity exceed the specifications. Picture quality will lower and internal parts may be damaged.  
Be particularly careful when using in places exposed to direct sunlight. When shooting in hot places, depending on the conditions of the object and the camera (for example when the gain is increased), noise in the form of vertical strips or white dots may occur. This is not a malfunction.

- **Handling of the protection cap.**  
Keep the protection cap away from children. Children may put them into mouth or swallow them accidentally. The protection cap protects the image sensing plane when the lens is removed from the camera, do not throw away.
- **When not using the camera for a longtime.**  
Stop supplying power.
- **When cleaning the camera.**  
Unplug the power source before cleaning. Clean with a soft dry cloth only. Do not use benzine, alcohol, thinner, household detergents, chemically treated cloths, etc. If used, coating and printed letters may be discolored. When cleaning the lens, use a lens cleaning paper, etc.
- **Avoid using or storing the camera in the following places:**  
Places filled with highly flammable gas.  
Places near gasoline, benzene, or paint thinner.  
Places subject to strong vibration.  
Places contacting chemicals (such as pesticides, rubber or vinyl products for a long period of time.
- **Preliminary confirmation of the location where the camera is installed (with a tripod not used)**  
Before installing the camera, make sure that the location can withstand the total weight of the camera.  
If the camera is installed in places where the strength of bearing it is insufficient, secure the structure by reinforcement etc., to bear the load.  
If the reinforcement strength is insufficient, the camera may drop, causing personal injury and malfunction.

# 2. COMPONENTS

(1) Camera .....	1
(2) Accessories	
(a) Instruction manual .....	1

### 3. NAMES AND FUNCTIONS

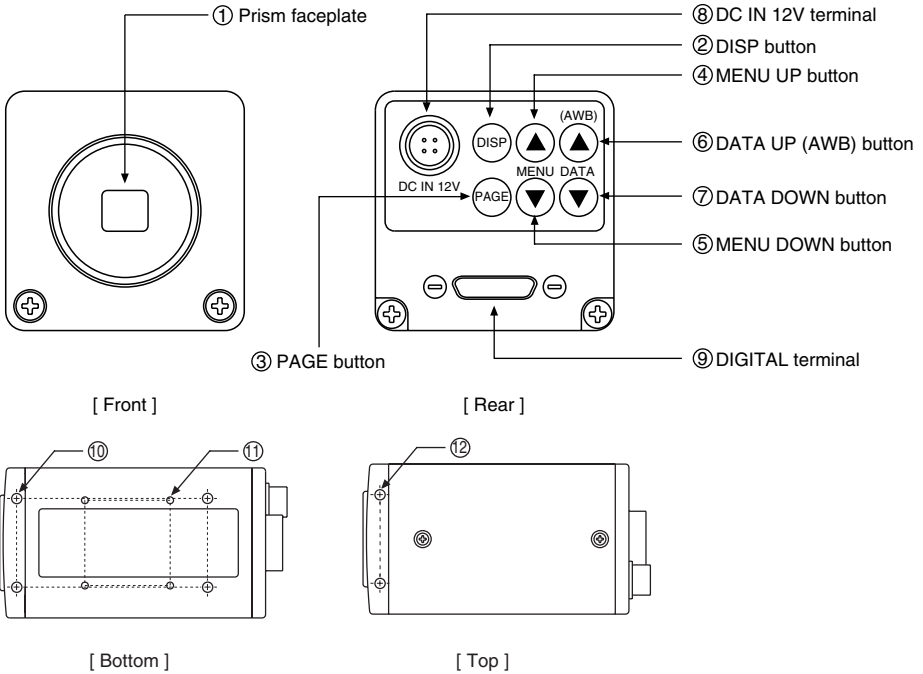

- |                        |                                                                                                                                                                                                                      |
|------------------------|----------------------------------------------------------------------------------------------------------------------------------------------------------------------------------------------------------------------|
| ① Prism faceplate      | The protection cap is attached on the lens mount portion. After removing the cap, mount the lens. Be careful not to scratch or touch the optical area.                                                               |
| ② DISP button          | Used when switching the display.                                                                                                                                                                                     |
| ③ PAGE button          | Used when switching to the menu and when selecting the menus.                                                                                                                                                        |
| ④ MENU UP button       | Select the function to be confirmed or changed on the menu.                                                                                                                                                          |
| ⑤ MENU DOWN button     | Select the function to be confirmed or changed on the menu.                                                                                                                                                          |
| ⑥ DATA UP (AWB) button | Changes the value of the function selected by the MENU (UP/DOWN) button. (Also used when using AWB.)                                                                                                                 |
| ⑦ DATA DOWN button     | Changes the value of the function selected by the MENU (UP/DOWN) button.                                                                                                                                             |
| ⑧ DC IN 12V terminal   | Accept a DC power input (12V).                                                                                                                                                                                       |
| ⑨ RGB terminal         | 8-bit RGB, digital signal, and sync signal are output in the Camera Link format.<br>Trigger signal is input.<br>Mode switching signal for partial scanning is input.<br>Accepts serial communication control signal. |
| ⑩ Mounting holes M3    | Used to fix the camera.                                                                                                                                                                                              |
| ⑪ Mounting holes M2    | Used to fix the camera.                                                                                                                                                                                              |
| ⑫ Mounting holes M3    | Used to fix the camera.                                                                                                                                                                                              |

# 4. CONNECTION

## 4.1 Standard Connection

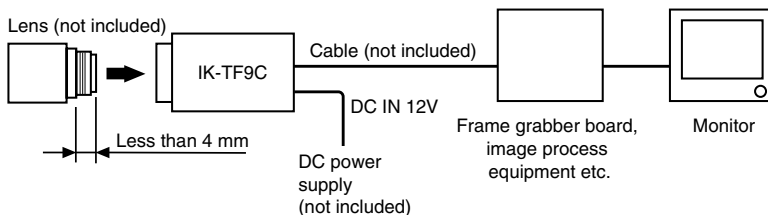

## 4.2 Cautions on Connection

- When connecting the camera cables, unplug the power source of the camera and the other equipment connected.

- We suggest using a C mount lens made for a 3CCD camera.

When using another lens, the best camera performance of this camera may not be obtained.

(For example, low resolution may occur, focus may be lost through the range of a zoom lens, and flare, ghost or shading may occur)

Furthermore, in order to avoid damaging the mounting portion of the camera head, use a lens which has projection dimension from the mounting base of less than 0.157"(4mm).

- For DC power supply connecting to DC IN 12V terminal, use UL listed and/or CSA approved ungrounding type AC adaptor with the specifications described below.

Power supply voltage	: 12V DC±10%
Current rating	: More than 830 mA
Ripple voltage	: Less than 50 mV(p-p)
Connector	: HR10A-7P-4S by HIROSE electronics Co. Ltd
	Pins 1, 2 : 12V
	Pins 3, 4 : GND

- Use the standard cable for Camera Link.

## 4.3 Connector Pin Assignments

DC IN 12V		DIGITAL				Function	I/O
1	+12V	1	GND	14	GND		-
2	+12V	2	X0-	15	X0+		O
3	GND	3	X1-	16	X1+		O
4	GND	4	X2-	17	X2+		O
		5	Xclk-	18	Xclk+		O
		6	X3-	19	X3+		O
		7	SerTC+	20	SerTC-	Serial communication control (RXD)	I
		8	SerTFG-	21	SerTFG+	Serial communication control (TXD)	O
		9	CC1-	22	CC1+	Trigger pulse input	I
		10	CC2+	23	CC2-	Partial scanning control	I
		11	CC3-	24	CC3+	NC	-
		12	CC4+	25	CC4-	NC	-
		13	GND	26	GND		-

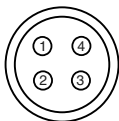

Connector used:  
HR10A-7P-4PB  
(HIROSE electronics  
Co. Ltd) or equivalent.

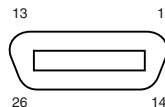

Connector used:  
12226-51000-00  
(3M) or equivalent.

## 5. OPERATION

- ① Refer to the item " 4. CONNECTION", connect each equipment correctly.
- ② Turn on the connected equipment and the power source of the camera.
- ③ Point the lens at the object, operate the lens iris adjustment, focus adjustment, etc..
- ④ Refer to the item "5.1 White Balance", operate the adjustment.
- ⑤ Refer to the items "7. MODE SETTING BY ON SCREEN DISPLAY", select the necessary items.

### 5.1 White Balance

For the white balance adjustment for this unit, AWB (Automatic White Balance) and MANU (Manual white balance) adjustments are provided. To select the desired mode, refer to the items "7.2 (3) WHT BAL (White balance)" and "7. MODE SETTING BY ON SCREEN DISPLAY".

	<b>AWB (Automatic White Balance)</b>	<b>MANU (Manual White Balance)</b>
<b>Outline</b>	Adjust white balance by displaying the white object inside the area set by AWB menu and pressing the [DATA UP] button.	Adjust the white balance manually using the WHT BAL menu while shooting the white object.
<b>Note</b>	When the shutter mode is E.TRG, AWB is not available.	Adjustment is performed by confirming with a monitor etc.

- ① AWB (Automatic white balance)
  - Set the MODE to AWB on the WHT BAL menu.  
Perform the C.TEMP (color temperature conversion) setting, if necessary.  
(Refer to the item "7.2 (3) WHT BAL (White balance)".)
  - 3200K : Appropriate for indoor shooting.
  - 5600K : Appropriate for outdoor shooting.
  - If the index menu/menu is displayed, press the [DISP] button to disable the character display on the menu.
  - Shoot a known white object that fills the screen and push [DATA UP] button for approx. 1 second.
  - The character AWB blinks on the screen when the AWB starts.
  - The character AWB stops blinking when the AWB finishes, and the result is displayed for approx. 1 second.

<b>Result displayed</b>	<b>Meaning</b>
<b>AWB OK</b>	Automatic white balance adjustment finished correctly.
<b>AWB NG LEVEL LOW</b>	Automatic white balance adjustment cannot be performed because the video level is too low. Obtain the proper video level.
<b>AWB NG LEVEL HIGH</b>	Automatic white balance adjustment cannot be performed because the video level is too high. Obtain the proper video level.
<b>AWB NG C. TEMP LOW</b>	Automatic white balance adjustment cannot be performed because the color temperature is too low. If the C.TEMP is set to 5600K, set to 3200K. If the message appears with the C.TEMP set to 3200K, change the illumination or use a color temperature conversion filter.
<b>AWB NG C. TEMP HIGH</b>	Automatic white balance adjustment cannot be performed because the color temperature is too high. If the C.TEMP is set to 3200K, set to 5600K. If the message appears with the C.TEMP set to 5600K, change the illumination or use the color temperature conversion filter.

<b>Result displayed</b>	<b>Meaning</b>
<b>AWB NG NOT AVAILABLE</b>	Automatic white balance adjustment cannot be performed because the shutter speed mode is E.TRG mode.
<b>AWB NG</b>	Automatic white balance adjustment cannot be performed for other reasons. Such as no white area is included in an object, etc.

② MANU (Manual white balance)

- Set the MODE to MANU on the WHT BAL menu.  
(Refer to the item "7.2 (3) WHT BAL (white balance)".)
- Shoot a known white object, adjust the white balance adjusting the levels of R GAIN and B GAIN on the menu, confirming with a monitor etc.  
(Refer to the item "7.2 (3) (3.2) Changing each setting in MANU (Manual) mode".)

## 6. ITEMS CONTROLLED BY USING ON SCREEN DISPLAY

Item		Available selections	Preset value (Factory setting)	
Electronic shutter	MODE	MANU, SS, E. TRG	MANU	
	E. TRG	1P SNR, 1P SR, PW SNR, PW SR	1P SNR	
	MANU speed	OFF, 1/100s, 1/250s, 1/500s, 1/1000s, 1/2000s, 1/4000s, 1/10000s, 1/25000s, 1/50000s, 1/100000s	OFF	
	Syncro. scan.	Partial read OFF	2H/1592H~1590H/1592H, OFF, 2FRM~512FRM	OFF
		Partial read 30fps	2H/1060H~1058H/1060H, OFF, 2FRM~512FRM	
		Partial read 40fps	2H/774H~772H/774H, OFF, 2FRM~512FRM	
	Partial read	OFF, 30fps, 40 fps, E.30fps, E.40fps	OFF	
	Trigger (1P SNR/SR)	⌚, ⌚	⌚	
	Trigger (PW SNR/SR)	⌚, ⌚	⌚	
1P exposure time	0.01ms~50ms	50 ms		
Gain	MODE	MANU, OFF	OFF	
	MANU	0dB~18dB	0dB	
White balance	MODE	AWB, MANU	AWB	
	Color temperature	3200K, 5600K	3200K	
	MANUAL R GAIN	-100~0~100	0	
	MANUAL B GAIN	-100~0~100	0	
Process	GAMMA	ON, OFF	OFF	
	Master pedestal	-64~0~64	0	
	R pedestal	-64~0~64	0	
	B pedestal	-64~0~64	0	
	Shading correction mode	MANU, OFF	MANU	
	Manual shading correction	-128~0~127	0	
Option	Baud rate	9600 bps, 19200 bps	9600 bps	

# 7. MODE SETTING BY ON SCREEN DISPLAY

Various settings can be controlled on the unit by using the on screen menu displayed on the monitor. The contents once set are memorized even if the power source is turned off, so it is unnecessary to set again when using the unit next time. When the setting is performed, select the menu of the item to be set.

## 7.1 Using the Menus

When the power is turned on, the normal screen showing only the video signal appears. Change the output to each screen (video signal output, Index menu, and menus) by using the [DISP], [PAGE], [MENU UP], and [MENU DOWN] buttons.

\* A menu is selected when pushing the [PAGE] button after moving the "→" on the screen by the [MENU UP], [MENU DOWN] button while the Index menu is displayed.

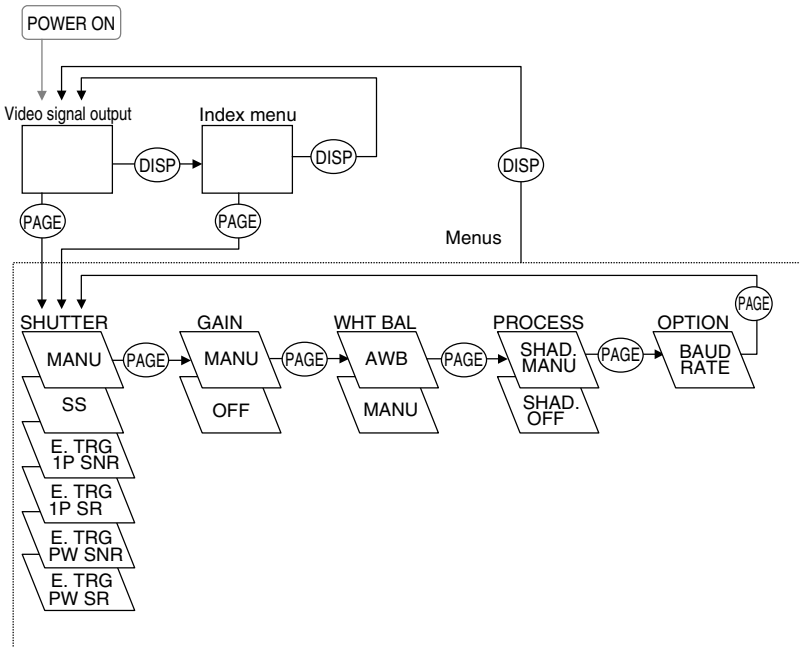

## 7.2 Menus

- Select the menu to change the setting by referring the item "7.1 Using the Menus".)
- When the [MENU UP], [MENU DOWN] buttons are pushed, the "→" on the screen moves up and down. Move the "→" to the item to change.

### Note:

**When performing the mode setting in the menu display while selecting ON in "PART" (refer to page 28) and E.TRG in "MODE", the display shows normal mode and then the camera returns the setting mode.**

### ( 1 ) SHUTTER (Electronic shutter)

The electronic shutter has three modes; MANU (Manual), SS (Synchro. Scan), E.TRG (External trigger).

Set the "→" to "MODE" and push [DATA UP], [DATA DOWN] button to select the desired mode among "MANU", "SS", "E.TRG".

MANUAL : It is possible to select the exposure time from eleven speed setting; OFF, 1/100s, 1/250s, 1/500s, 1/1000s, 1/2000s, 1/4000s, 1/10000s, 1/25000s, 1/50000s, 1/100000s.

#### Note:

**When setting a rapid shutter speed, sensitivity degrades according to the speed. When a discharging light such as fluorescent lamp, etc. is used for the illumination, the flicker may be large.**

SS : Shutter speed can be set by the double horizontal scanning time (2H) unit or by the frame unit.

E.TRG : Exposure is performed and images are output by external trigger. E.TRG includes the four modes described below. (For details of specifications, refer to the item "7.4 E.TRG (External trigger)".)

- 1P SNR (1 Pulse Sync Non Reset)

The charge begins to accumulate after the trigger pulse is received, and 1 frame images are output according to the internal vertical sync signal timing. The exposure/accumulation time can be set from 0.01 to 50 ms. The trigger signal timing can be set to either the rising or falling edge.

- 1P SR (1 Pulse Sync Reset)

The charge begins to accumulate after the trigger pulse is received. Upon completion of accumulation the vertical sync signal is reset and 1 frame images are output. The exposure/accumulation time can be set from 0.01 to 50 ms. The trigger signal timing can be set to either the rising or falling edge.

- PW SNR (Pulse width trigger Sync Non Reset)

The charge begins to accumulate after the trigger pulse is received, and 1 frame images are output according to the internal vertical sync signal timing. This is the mode to set the exposure period by the pulse width of the trigger. The trigger signal polarity can be set to either the positive or negative polarity.

- PW SR (Pulse width trigger Sync Reset)

The charge begins to accumulate after the trigger pulse is received. Upon completion of accumulation the vertical sync signal is reset and 1 frame images are output. This is the mode to set the exposure period by the pulse width of the trigger. The trigger signal polarity can be set to either the positive or negative polarity.

**(1. 1) Changing each setting in MANU mode**

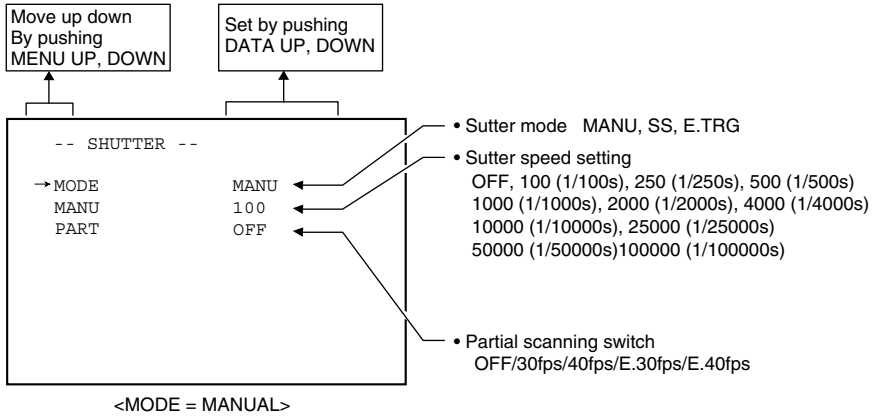

**(a) Changing the shutter speed**

- ① Set the "→" to MANU by pushing [MENU UP], [MENU DOWN] buttons.
- ② Set the shutter speed by pushing [DATA UP], [DATA DOWN] buttons.

**(b) Partial scanning setting**

- ① Set the "→" to PART by pushing [MENU UP], [MENU DOWN] buttons.
- ② Select either OFF/30fps/40fps/E.30fps/E.40fps by pushing [DATA UP], [DATA DOWN] buttons.

## (1. 2) Changing each setting in SS (synchro. scan) mode

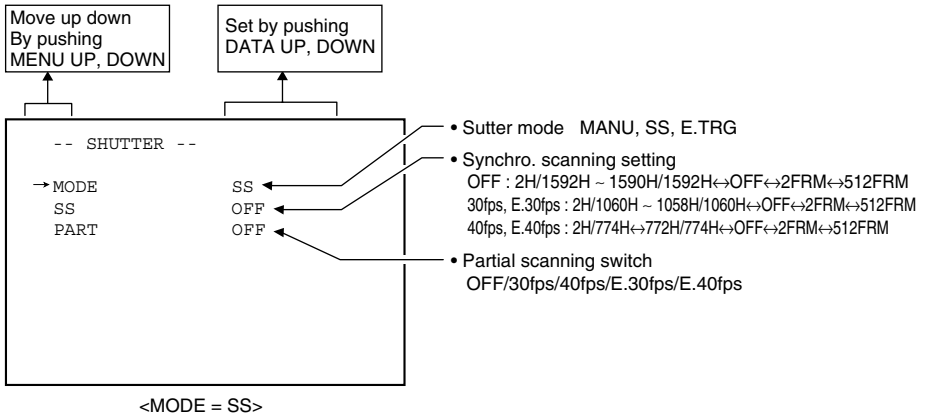

### (a) Changing the shutter speed setting

- ① Set the "→" to SS by pushing [MENU UP], [MENU DOWN] buttons.
- ② Select the shutter speed by pushing [DATA UP], [DATA DOWN] buttons.

### (b) Partial scanning setting

- ① Set the "→" to PART by pushing [MENU UP], [MENU DOWN] buttons.
- ② Select either OFF/30fps/40fps/E.30fps/E.40fps by pushing [DATA UP], [DATA DOWN] buttons.

#### Note:

**The slow shutter speed may increase the fixed pattern noise and/or the white pixels. This is a characteristic of CCD, and is not a symptom of malfunction.**

**(1. 3) Changing each setting in E.TRG mode**

The E.TRG has four modes; 1P SNR, 1P SR, PW SNR, PW SR.

First set the "→" to MODE and select E. TRG, then set the "→" to E.TRG and select the desired E.TRG mode.

**(1. 3. 1) Changing each setting in 1P SNR mode**

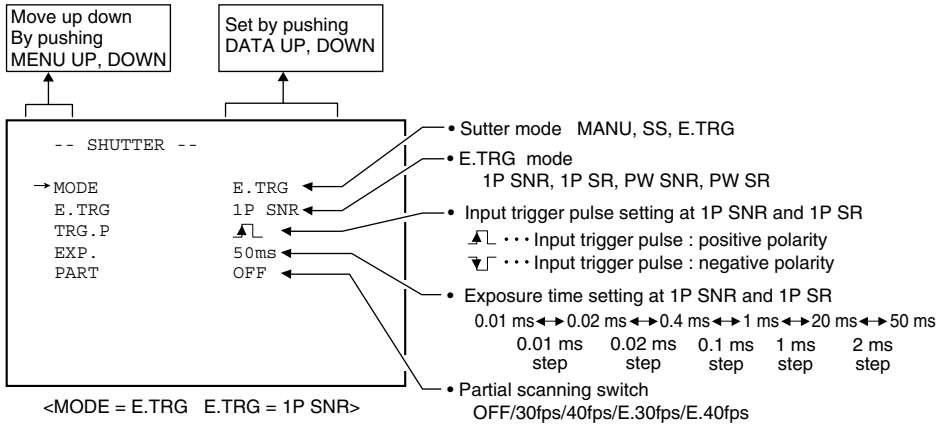

**(a) Changing the polarity of inputting trigger pulse setting**

- ① Set the "→" to TRG.P by pushing [MENU UP], [MENU DOWN] buttons.
- ② Select either ▲ ▭, ▼ ▭ by pushing [DATA UP], [DATA DOWN] buttons.

**(b) Changing 1P SNR exposure time setting**

- ① Set the "→" to EXP. by pushing [MENU UP], [MENU DOWN] buttons.
- ② Set the exposure time by pushing [DATA UP], [DATA DOWN] buttons.

**(c) Changing the partial scanning setting**

- ① Set the "→" to PART by pushing [MENU UP], [MENU DOWN] buttons.
- ② Select either OFF/30fps/40fps/E.30fps/E.40fps by pushing [DATA UP], [DATA DOWN] buttons.

### (1. 3. 2) Changing each setting in 1P SR mode

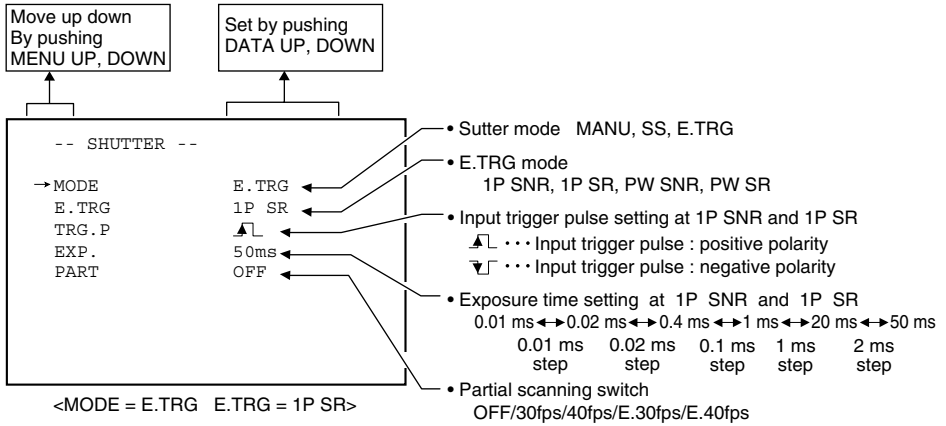

#### (a) Changing the polarity of inputting trigger pulse setting

- ① Set the "→" to TRG.P by pushing [MENU UP], [MENU DOWN] buttons.
- ② Select either ▲┐, ▼┐ by pushing [DATA UP], [DATA DOWN] buttons.

#### (b) Changing 1P SR exposure time setting

- ① Set the "→" to EXP. by pushing [MENU UP], [MENU DOWN] buttons.
- ② Set the exposure time by pushing [DATA UP], [DATA DOWN] buttons.

#### (c) Changing the partial scanning setting

- ① Set the "→" to PART by pushing [MENU UP], [MENU DOWN] buttons.
- ② Select either OFF/30fps/40fps/E.30fps/E.40fps by pushing [DATA UP], [DATA DOWN] buttons.

**(1. 3. 3) Changing each setting in PW SNR mode**

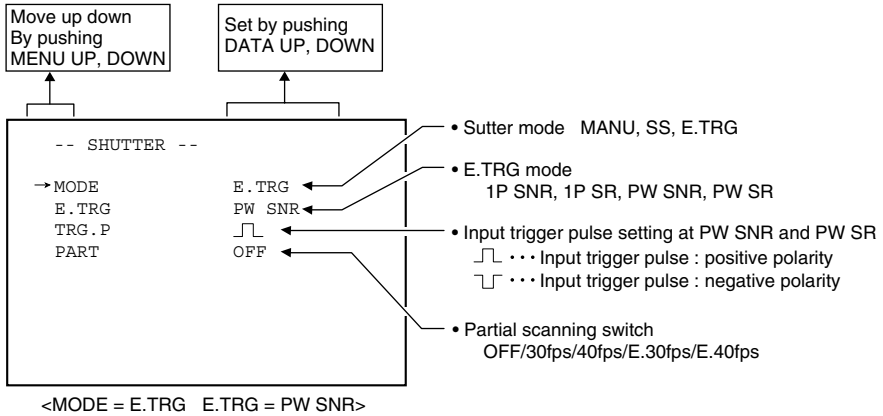

**(a) Changing the polarity of inputting trigger pulse setting**

- ① Set the "→" to TRG.P by pushing [MENU UP], [MENU DOWN] buttons.
- ② Select either [High Pulse], [Low Pulse] by pushing [DATA UP], [DATA DOWN] buttons.

**(b) Changing the partial scanning setting**

- ① Set the "→" to PART by pushing [MENU UP], [MENU DOWN] buttons.
- ② Select either OFF/30fps/40fps/E.30fps/E.40fps by pushing [DATA UP], [DATA DOWN] buttons.

**Note:**

**The longer the storage time with extended exposures, the more visible certain characteristics of CCD cameras become: fixed pattern noise, white pixels, etc.**

### (1. 3. 4) Changing each setting in PW SR mode

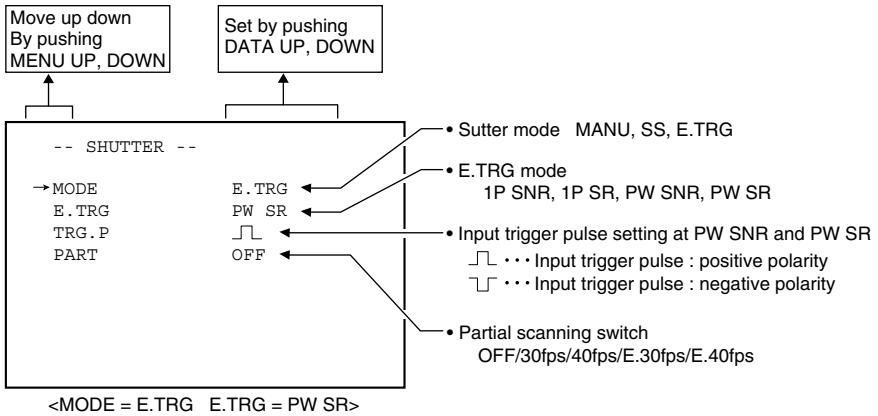

#### (a) Changing the polarity of inputting trigger pulse setting

- ① Set the "→" to TRG.P by pushing [MENU UP], [MENU DOWN] buttons.
- ② Select either □ □, □ □ by pushing [DATA UP], [DATA DOWN] buttons.

#### Note:

The longer the storage time with extended exposures, the more visible certain characteristics of CCD cameras become: fixed pattern noise, white pixels, etc.

## ( 2 ) GAIN (Video gain)

When the image is dark even if the lens iris is open, change the gain (video gain) to get the proper video level. For the gain adjustment of the unit, MANU (Manual) and OFF (0dB) modes are provided.

① MANU (Manual gain)

Gain adjustment is performed on the GAIN menu. The adjustment range is from 0dB to 18dB in 1dB steps.

② OFF

Gain is fixed at 0dB.

Set the "→" to MODE, push the [DATA UP], [DATA DOWN], and select mode among MANU, OFF.

### (2. 1) Changing each setting in GAIN

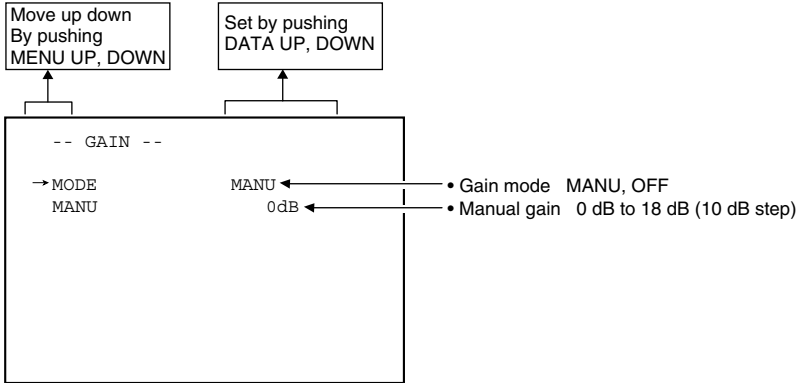

#### (a) Changing the gain in MANU mode

① Set the "→" to MANU by pushing [MENU UP], [MENU DOWN] buttons.

② Set the manual gain by pushing [DATA UP], [DATA DOWN] buttons.

### ( 3 ) WHT BAL (White balance)

WHT BAL has two modes; AWB, MANU.

Set the "→" to MODE, push the [DATA UP], [DATA DOWN], and select mode among AWB, MANU.

#### (3.1) Changing each setting in AWB (Automatic White Balance) mode

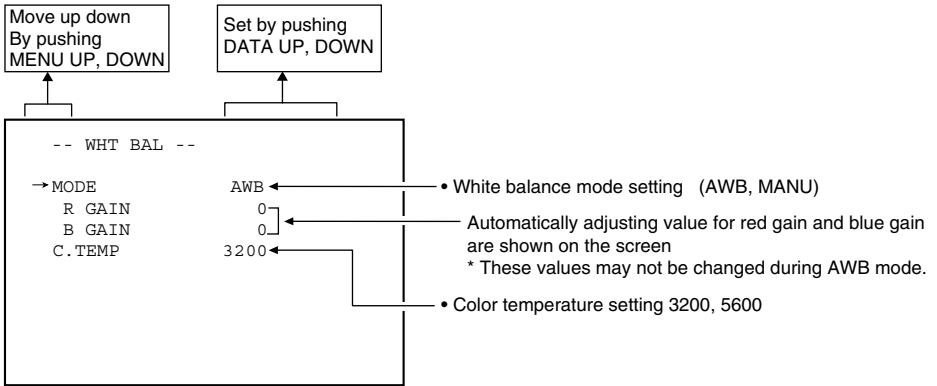

#### (a) Changing color temperature setting

- ① Set the "→" to C.TEMP by pushing [MENU UP], [MENU DOWN] buttons.
- ② Select either 3200 or 5600 by pushing [DATA UP], [DATA DOWN] buttons.

#### (3.2) Changing each setting in MANU (Manual) mode

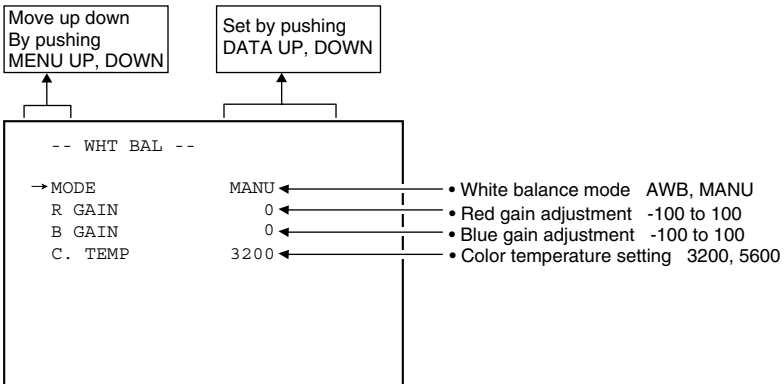

#### (a) Changing the red gain

- ① Set the "→" to R GAIN by pushing [MENU UP], [MENU DOWN] buttons.
- ② Set the red gain by pushing [DATA UP], [DATA DOWN] buttons.

#### (b) Changing the blue gain

- ① Set the "→" to B GAIN by pushing [MENU UP], [MENU DOWN] buttons.
- ② Set the blue gain by pushing [DATA UP], [DATA DOWN] buttons.

## (4) PROCESS

- Gamma Correction (GAMMA)  
Select either OFF or ON of Gamma Correction.
- Master Pedestal (M. PED)  
Set the Pedestal level of each RGB.
- R Pedestal (R. PED)  
Set the Pedestal level of Red.
- B Pedestal (B. PED)  
Set the Pedestal level of Blue.
- Shading Correction (SHAD.)  
Due to the lens used or the environmental condition, vertical color shading may occur at the top and bottom of the screen. In this case, the shading correction can decrease the color shading. For the shading correction of the unit, MANU (Manual shading correction) and OFF (no shading correction) modes are provided.

① MANU (Manual Shading)

Adjust the correction amount on the PROCESS menu by confirming with a monitor or a waveform monitor.

② OFF

The status is no shading correction.

**\* The shading correction is effective when the lens iris or zoom ratio is fixed. Use the unit with SHAD. OFF for variable lens conditions.**

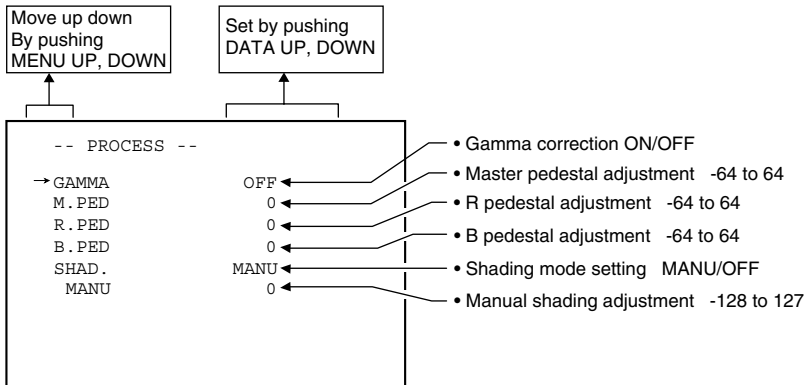

### (4.1) Changing gamma correction

- ① Set the "→" to GAMMA by pushing [MENU UP], [MENU DOWN] buttons.
- ② Set the gamma correction by pushing [DATA UP], [DATA DOWN] buttons.

### (4.2) Changing master pedestal

- ① Set the "→" to M. PED by pushing [MENU UP], [MENU DOWN] buttons.
- ② Set the master pedestal by pushing [DATA UP], [DATA DOWN] buttons.

### (4.3) Changing R pedestal

- ① Set the "→" to R. PED by pushing [MENU UP], [MENU DOWN] buttons.
- ② Set the R pedestal by pushing [DATA UP], [DATA DOWN] buttons.

### (4.4) Changing B pedestal

- ① Set the "→" to B. PED by pushing [MENU UP], [MENU DOWN] buttons.
- ② Set the B pedestal by pushing [DATA UP], [DATA DOWN] buttons.

#### (4. 5) Changing the shading correction mode

- ① Set the "→" to SHAD. by pushing [MENU UP], [MENU DOWN] buttons.
- ② Set the SHAD. by pushing [DATA UP], [DATA DOWN] buttons.

**Note:** The alignment value for shading is fixed to "0" when selecting SHAD. OFF. MANU is not displayed in the menu.

#### (4. 6) Changing the manual shading correction setting

- ① Set the "→" to MANU by pushing [MENU UP], [MENU DOWN] buttons.
- ② Set the MANUAL SHADING by pushing [DATA UP], [DATA DOWN] buttons.

### ( 5 ) OPTION

#### (5. 1) Changing serial communication baud rate

- ① Set the "→" to BAUD RATE by pushing [MENU UP], [MENU DOWN] buttons.
- ② Select either 9600 or 19200 by pushing [DATA UP], [DATA DOWN] buttons.

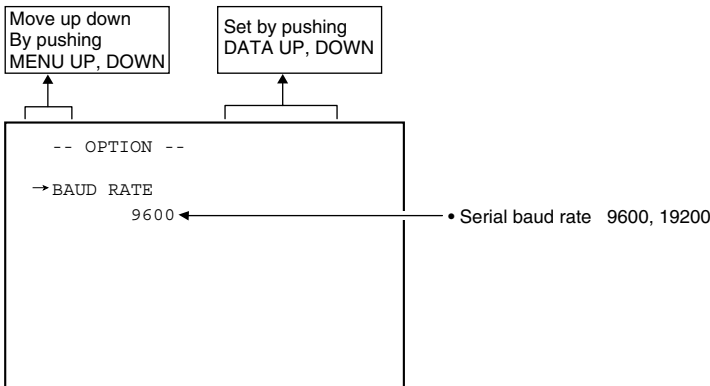

#### ( 6 ) Setting to factory setting status

All the settings can be returned to the factory default status (preset status).

- (1) If characters are displayed on the screen, press the [DISP] button to disable the character display.
- (2) Push [MENU DOWN] and [DATA DOWN] buttons simultaneously for approx. 1 second.
- (3) The preset operation starts. When the preset operation finishes, the character PRESET OK is displayed for approx. 1 second.

### 7.3 Synchro. Scan Operation

The shutter speed can be set by the double horizontal scanning period (2H) or by the frame.

#### ( 1 ) Setting by 2H

2H/1592H ~ 1590H/1592H (2H/1060H ~ 1058H/1060H at 30fps and E.30fps of Partial Scanning, 2H/774H ~ 772H/774H at 40fps and E.40fps of Partial Scanning) stands for the setting by the 2H and the shutter speed can be set by the 2H (62.8  $\mu$ s).

#### ( 2 ) Setting by the frame

2FRM to 512FRM stand for the setting (long period exposure) by the frame.

The video signal stored during the frame period set is output as 1 frame video image at a frame interval specified.

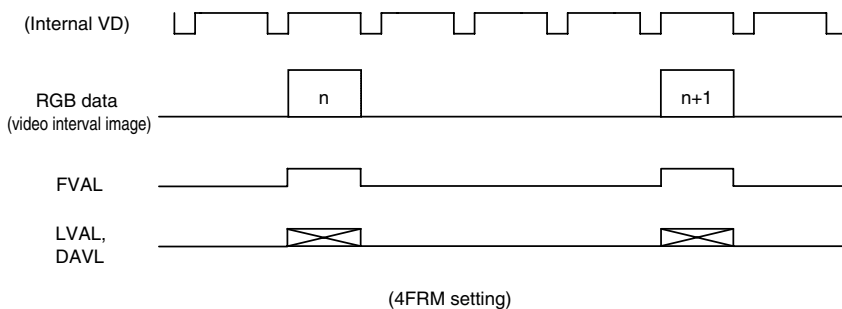

## 7.4 E. TRG (External trigger)

Charge begins to accumulate after the trigger input to CC1 of the DIGITAL terminal, and 1 frame images are output. There are four modes: 1P SNR, 1P SR, PW SNR, PW SR.

### (1) 1P SNR (1 Pulse Trigger Sync Non Reset)

Charge begins to accumulate after the trigger input to CC1 of the DIGITAL terminal, and 1 frame images are output.

#### (1.1) 1 Pulse Trigger SYNC-NON RESET Picture Output Timing

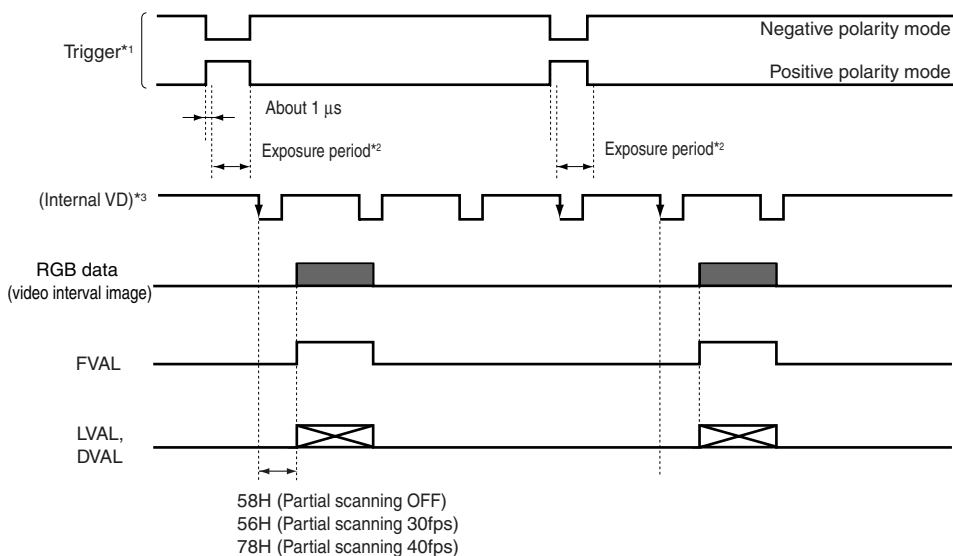

\*1: Externally input signal

\*2: Exposure time is determined by the setting of "7. 2 (1.3) Changing each setting in E. TRG mode".

\*3: Video is output at the falling edge of the internal VD following completion of the exposure period.

The video and FVAL/LVAL/DVAL have a paired relationship.

#### Note:

**When the next trigger is input before completion of the output of the video corresponding to the trigger, there will be an effect on the video.**

**( 2 ) 1P SR (1 Pulse Trigger Sync Reset)**

Charge begins to accumulate after the trigger input to CC1 of the DIGITAL terminal, the vertical sync signal is reset and frame images are output.

**(2. 1) 1 Pulse Trigger SYNC-RESET Picture Output Timing**

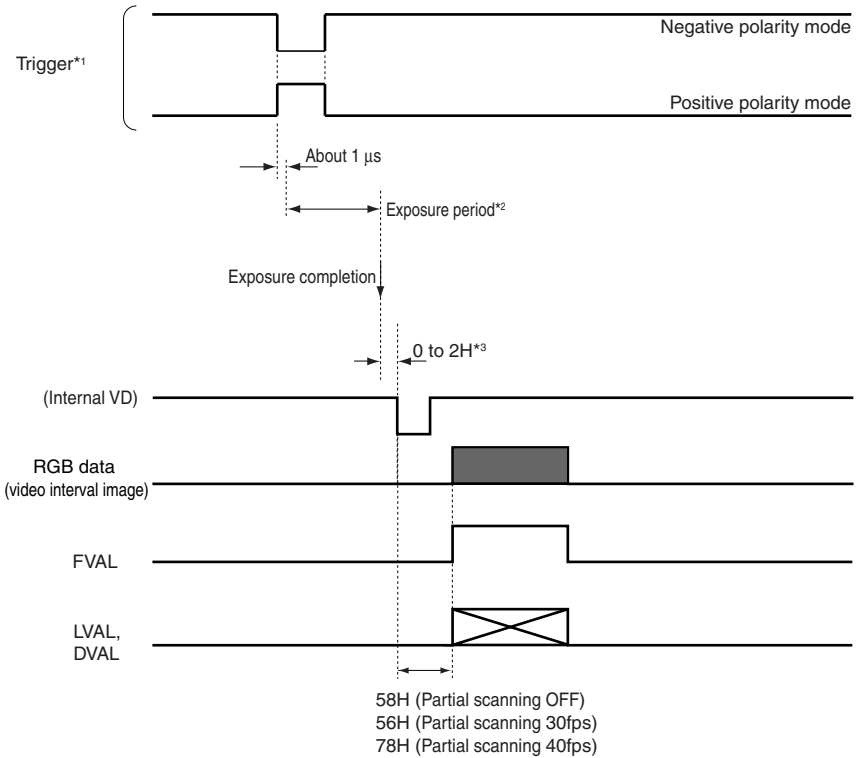

\*1: Externally input signal

\*2: Exposure time is determined by the setting of "7. 2 (1.3) Changing each setting in E.TRG mode".

\*3: VD is generated after 0 to 2H following the completion of the exposure period and the video is synchronized to this and output.

**Note:**

**When the next trigger is input before completion of the output of the video corresponding to the trigger, there will be an effect on the video.**

### ( 3 ) PW SNR (Pulse width trigger SYNC-NON RESET)

The trigger input to CC1 of the DIGITAL terminal develops 1 frame images.

#### (3. 1) Pulse Width Trigger SYNC-NON RESET Picture Output Timing

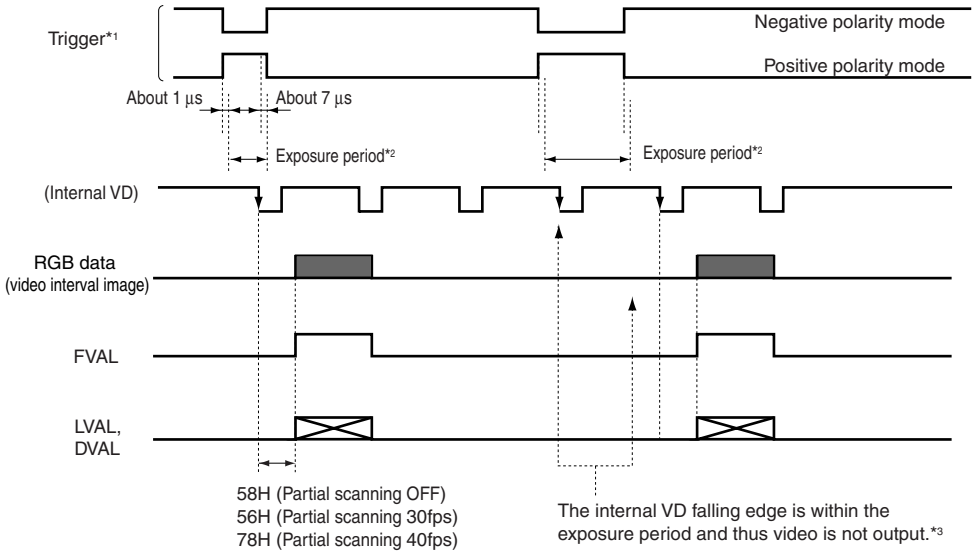

\*1: Externally input signal

\*2: Exposure time = Trigger pulse width + 6  $\mu$ s  
(Valid trigger pulse width is 2  $\mu$ s or greater for external trigger shutter operation.)

\*3: Video is output at the falling edge of the internal VD following completion of the exposure period.  
The video and FVAL/LVAL/DVAL have a paired relationship.

**Note:**

**When the next trigger is input before completion of the output of the video corresponding to the trigger, there will be an effect on the video.**

**( 4 ) PW SR (Pulse width trigger SYNC-RESET)**

The trigger input to the CC1 of the DIGITAL terminal develops 1 frame images.

**(4. 1) 1 Pulse Width Trigger SYNC-RESET Picture Output Timing**

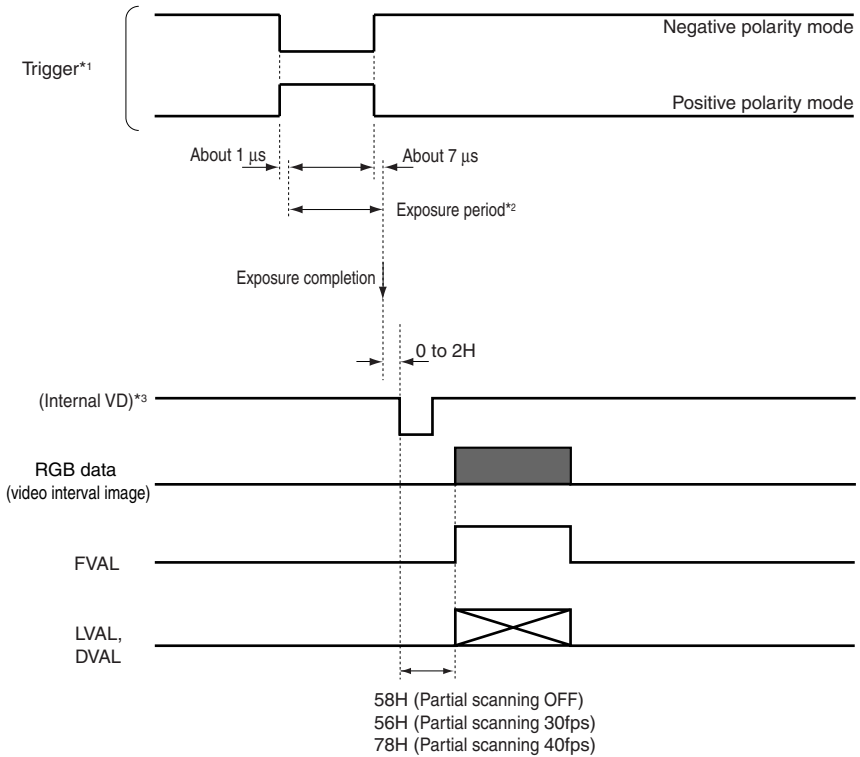

\*1: Externally input signal

\*2: Exposure time = Trigger pulse width + 6 μs

(Valid trigger pulse width is 2 μs or greater for external trigger shutter operation.)

\*3: VD is generated after 0 to 2H following the completion of the exposure period and the video is synchronized to this and output.

**Note:**

**When the next trigger is input before completion of the output of the video corresponding to the trigger, there will be an effect on the video.**

## 7.5 Partial Read

### ( 1 ) Partial Scanning OFF (All pixels scanning)

In this mode, all pixels independent signal from the DIGITAL connector is output each 1/20 second (Line order output).

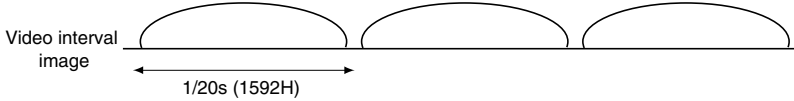

### ( 2 ) Partial Scanning ON

In this mode, the pixel signal of the vertical center portion from the DIGITAL connector is output.

In the E.30fps or E.40fps mode, the partial scanning and the all pixels scanning can be switched by the DIGITAL terminal (CC2: partial scanning control signal).

CC2	E.30fps	E.40fps
'L'	Partial scanning 30fps	Partial scanning 40fps
'H'	All pixels scanning	All pixels scanning

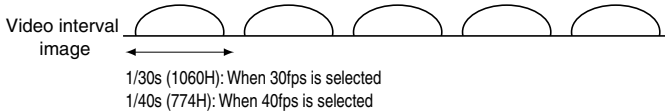

### ( 3 ) When Partial Scanning Mode is ON

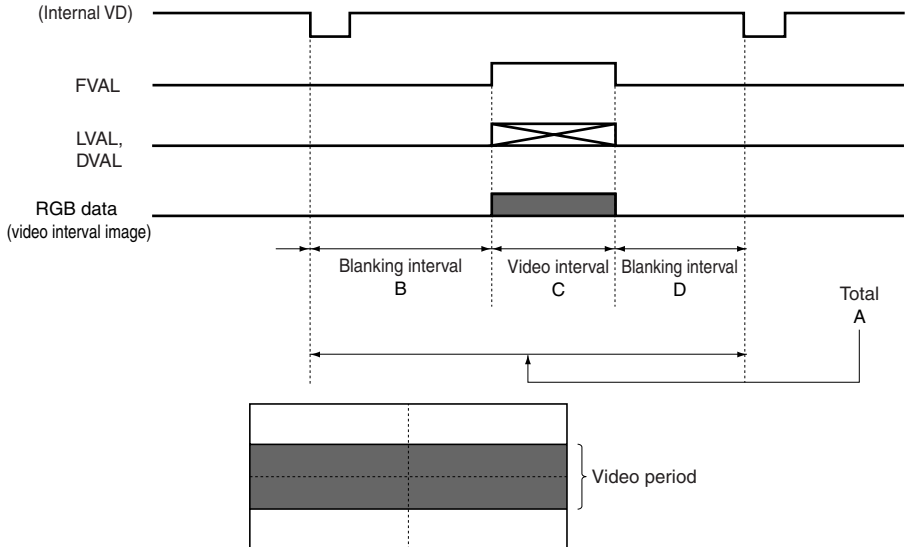

Mode	Total A	Blanking interval B	Video interval C	Blanking interval D
30fps	1060H	56H	972H	32H
40fps	774H	78H	644H	52H

# 8. OUTPUT WAVEFORM TIMING CHART

## ( 1 ) Horizontal Output Waveform Timing Chart

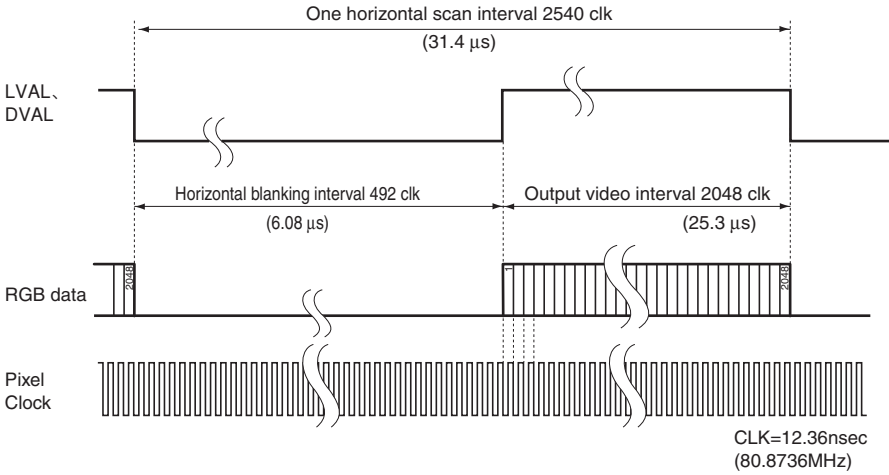

## ( 2 ) Vertical Output Waveform Timing Chart

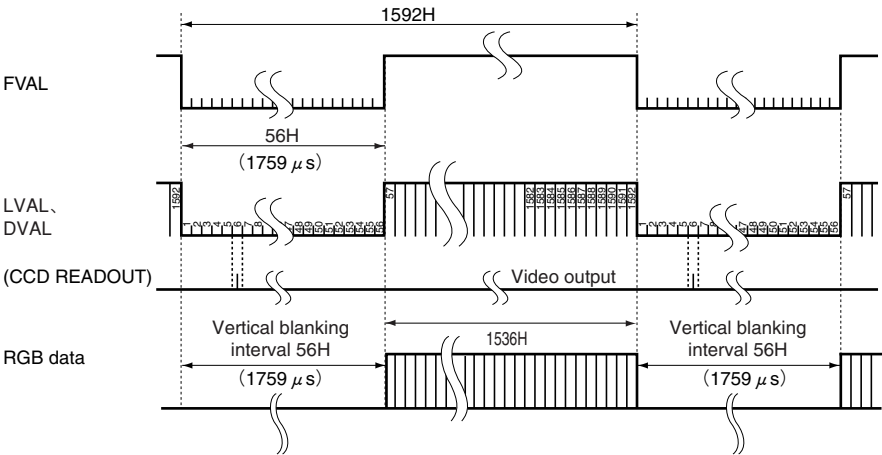

## 9. SPECIFICATIONS

Power supply	12V DC±10%
Power consumption	Approx. 4.8W
Pick-up system	RGB, 3CCD
Image sensor	1/3inch All pixels CCD (Effective pixels Horizontal : 1034, Vertical : 779)
Scanning System	Progressive scan
Video output pixels	Horizontal pixels : 2048, Vertical : 1536
Pixel clock frequency	80.8736MHz
Sync signal frequency	Horizontal : 31.84KHz, Vertical : 20Hz
Sync system	Internal
Sensitivity	F8 standard (2000 lx, 3000K)
Minimum illumination	10 lx (F2.2, Sensitivity + 18 dB, 3000K)
Lens mount	C mount (flange back : 17.526 mm in-air)
Ambient temperature	32 to 104°F (0 to 40°C)
Ambient humidity	Less than 90%
Weight	Approx. 5.82oz (165g)
External dimension	1.73" (W) x 1.73" (H) x 3.07" (D) (44 (W) x 44 (H) x 78 (D) mm) (except for protruded portion)
White balance	AWB (Automatic white balance), MANUAL (Manual)
Gain	MANUAL (Manual), OFF (0 dB)
Partial scanning	30fps (Effective lines: 972), 40fps (Effective lines: 644)
Output signal	8-bit RGB, Digital output (Camera Link format)
Sync signal output	FVAL, LVAL, DVAL (Positive polarity) Pixel Clock
External trigger input	CC1 (LVDS input), More than 2 μs pulse width
Partial scanning control signal input	CC2 (LVDS input)
Interface	Serial data interface : Ser TC (RXD), Ser TFG (TXD)
Optional parts	EXC-CL05S (Cable), etc

The designs and specifications are subject to change without notice.

# 10. EXTERNAL APPEARANCE DIAGRAM

Unit : mm [inch]

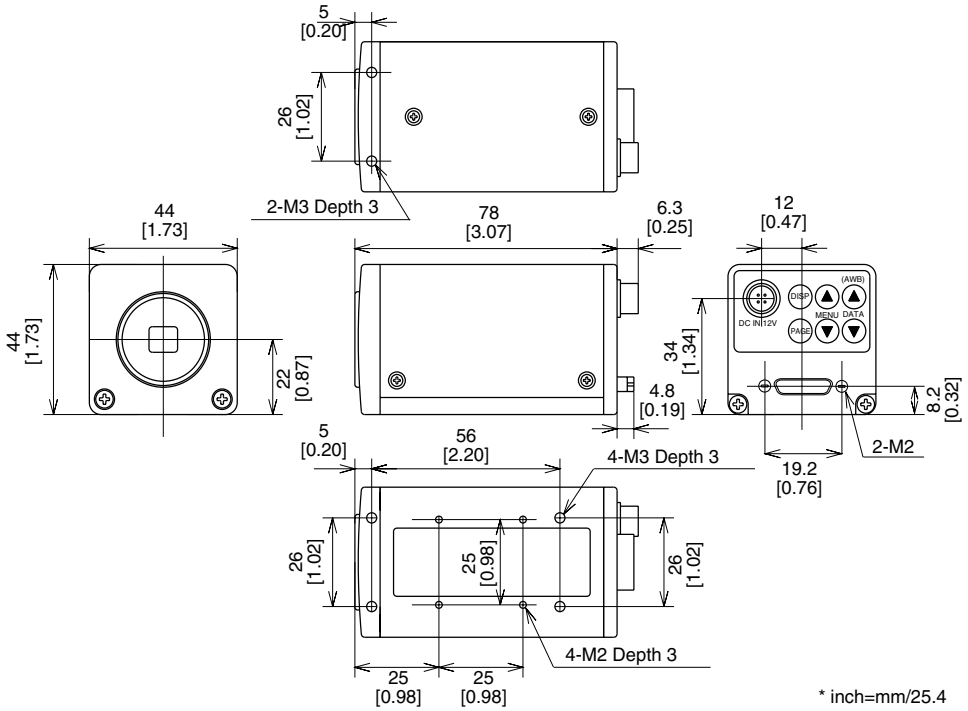

\* inch=mm/25.4

# 11. BEFORE MAKING A SERVICE CALL

Symptom	Items to be checked
No image	<ul style="list-style-type: none"> <li>• Is the power supplied correctly?</li> <li>• Is the lens iris adjusted correctly?</li> <li>• Are the cables connected correctly?</li> <li>• Is the shutter mode set correctly?</li> <li>• Is the image process equipment set correctly?</li> </ul>
Poor color	<ul style="list-style-type: none"> <li>• Is the monitor adjusted correctly?</li> <li>• Is the white balance of the camera adjusted correctly?</li> <li>• Is the illumination dark?</li> </ul>

## **LIMITED WARRANTY TOSHIBA CCD CAMERA**

The Imaging Systems Division of Toshiba America Information Systems, Inc. ("ISD") makes the following limited warranties. These limited warranties extend to the Original End-User ("You[r]").

### **Limited One (1) Year Warranty of Labor and Parts**

ISD warrants this product and parts against defects in material or workmanship for a period of one year from the date of original retail purchase by the end-user. During this period, ISD will repair or replace a defective product or part with a new or refurbished item. The user must deliver the entire product to an ISD authorized service center. The user is responsible for all transportation and insurance charges for the product to the Service Center. ISD reserves the right to substitute Factory Refurbished Parts and / or Factory Refurbished Product in place of those in need of repair.

### **Step-by-step Procedures - How to Obtain Warranty Service**

- [1] Verify operation of the unit by checking the instruction manual
- [2] If there is a defect in material or workmanship, contact an Authorized Service Provider within 30 days after the product fails to comply with specifications.
- [3] Arrange for delivery of the product to the ISD authorized service center. Products must be insured and securely packed, preferably in the original shipping carton. A letter explaining the defect and a copy of the bill of sale or other proof of purchase must be enclosed with a complete return street address and daytime telephone number. Charges for transportation and insurance must be prepaid by the end-user.

**Questions?** If you have any questions, please check the Toshiba Imaging Systems Division Web site as follows:

**Website:**    <http://www.toshiba.com/taisid/indmed>

### **Your Responsibility, warranties are subject to the following conditions:**

- [1] You must retain the bill of sale or provide other proof of purchase.
- [2] You must schedule service within thirty days after you discover a defective product or part.
- [3] All warranty servicing of this product must be made by a Toshiba ISD Authorized Service Provider.
- [4] The warranty extends to defects in material or workmanship as limited above, and not to any products or parts that have been lost or discarded by user. The warranty does not cover damage caused by misuse, accident, improper installation, improper maintenance, or use in violation of instructions furnished by ISD. The warranty does not extend to units which have been altered or modified without authorization of ISD, or to damage to products or parts thereof which have had the serial number removed, altered defaced or rendered illegible.

**ALL WARRANTIES IMPLIED BY STATE LAW, INCLUDING THE IMPLIED WARRANTIES OF MERCHANTABILITY AND FITNESS FOR A PARTICULAR PURPOSE, ARE EXPRESSLY LIMITED TO THE DURATION OF THE LIMITED WARRANTIES SET FORTH ABOVE. Some states do not allow limitations on how long an implied warranty lasts, so the above limitation may not apply. WITH THE EXCEPTION OF ANY WARRANTIES IMPLIED BY STATE LAW AS HEREBY LIMITED, THE FOREGOING EXPRESS WARRANTY IS EXCLUSIVE AND IN LIEU OF ALL OTHER WITH RESPECT TO THE REPAIR OR REPLACEMENT OF ANY PRODUCTS OR PARTS. IN NO EVENT SHALL ISD BE LIABLE FOR CONSEQUENTIAL OR INCIDENTAL DAMAGES. Some states do not allow the exclusion or limitation of incidental or consequential damages so the above limitation may not apply.**

**No person, agent, distributor, dealer, service station or company is authorized to change, modify or extend the terms of these warranties in any manner whatsoever. The time within which an action must be commenced to enforce any obligation of ISD arising under this warranty or under any statute, or law of the United States or any state thereof, is hereby limited to one year from the date you discover or should have discovered, the defect. This limitation does not apply to implied warranties arising under state law. Some states do not permit limitation of the time within which you may bring an action beyond the limits provided by state law so the above provision may not apply to user. This warranty gives the user specific legal rights, and user may also have other rights, which may vary from state to state.**

**TOSHIBA AMERICA INFORMATION SYSTEMS, INC.**  
Imaging Systems Division

**TOSHIBA**