

TOSHIBA

Leading Innovation >>>

Integrated High Definition LED TV/DVD Combination User's Guide:

24V4210U
24V4260U

If you need assistance:

Toshiba's Support Web site support.toshiba.com

Call Toshiba Customer Support Center:

Within the United States at (800) 631-3811

Outside the United States at (949) 583-3050

For more information, see “[Troubleshooting](#)” on [page 147](#) in this guide.

Owner's Record

The model number and serial number are on the back and side of your TV.

Record these numbers in the spaces below. Refer to these numbers whenever you communicate with your Toshiba dealer about this LED TV/DVD combination.

Model number: _____

Serial number: _____

Note: To display a High Definition picture, the TV must be receiving a High Definition signal (such as an over-the-air High Definition TV broadcast, a High Definition digital cable program, or a High Definition digital satellite program). For details, contact your TV antenna installer, cable provider, or

GMA300010013
4/12

Dear Customer,

Thank you for purchasing this Toshiba LED TV. This manual will help you use the many exciting features of your new LED TV/DVD combination. Before operating your LED TV/DVD combination, carefully read this manual completely.

Safety Precautions

WARNING: TO REDUCE THE RISK OF FIRE OR ELECTRIC SHOCK, DO NOT EXPOSE THIS APPLIANCE TO RAIN OR MOISTURE.



WARNING: TO REDUCE THE RISK OF ELECTRIC SHOCK, DO NOT REMOVE COVER (OR BACK). NO USER-SERVICEABLE PARTS INSIDE. REFER SERVICING TO QUALIFIED SERVICE PERSONNEL.



The lightning flash with arrowhead symbol, within an equilateral triangle, is intended to alert the user to the presence of uninsulated "dangerous voltage" within the product's enclosure that may be of sufficient magnitude to constitute a risk of electric shock to persons.



The exclamation point within an equilateral triangle is intended to alert the user to the presence of important operating and maintenance (servicing) instructions in the literature accompanying the appliance.

WARNING

To prevent injury, this apparatus must be securely attached to the floor/wall in accordance with the installation instructions. See item 26) on page 4.

WARNING: If you decide to wall mount this television, always use a mounting bracket that has been Listed by an independent laboratory (such as UL, CSA, ETL) and is appropriate for the size and weight of this television. The use of inappropriate or non-listed mounting brackets could result in serious bodily injury and/or property damage. See "To Display your LED TV/DVD combination using a Wall Bracket," on page 5.

NOTE TO CATV INSTALLERS

This is a reminder to call the CATV system installer's attention to Article 820-40 of the U.S. NEC, which provides guidelines for proper grounding and, in particular, specifies that the cable ground shall be connected to the grounding system of the building, as close to the point of cable entry as practical. For additional antenna grounding information, see 33) and 34) on page 4.

CHILD SAFETY:

It Makes A Difference How and Where You Use Your Flat Panel Display

Congratulations on your purchase! As you enjoy your new product, please keep these safety tips in mind:

The Issue

The home theater entertainment experience is a growing trend and larger flat panel displays are popular purchases. However, flat panel displays are not always supported on the proper stands or installed according to the manufacturer's recommendations.

- Flat panel displays that are inappropriately situated on dressers, bookcases, shelves, desks, speakers, chests or carts may fall over and cause injury.



TOSHIBA Cares!

The consumer electronics industry is committed to making home entertainment enjoyable and safe.

Tune Into Safety

- One size does NOT fit all. Follow the manufacturer's recommendations for the safe installation and use of your flat panel display.
- Carefully read and understand all enclosed instructions for proper use of this product.
- Don't allow children to climb on or play with furniture and television sets.
- Don't place flat panel displays on furniture that can easily be used as steps, such as a chest of drawers.
- Remember that children can become excited while watching a program, especially on a "larger than life" flat panel display. Care should be taken to place or install the display where it cannot be pushed, pulled over, or knocked down.
- Care should be taken to route all cords and cables connected to the flat panel display so that they cannot be pulled or grabbed by curious children.

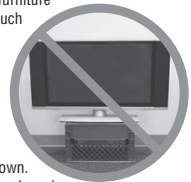

Wall Mounting: If you decide to wall mount your flat panel display, always:

- Use a mount that has been recommended by the display manufacturer and/or listed by an independent laboratory (such as UL, CSA, ETL).
- Follow all instructions supplied by the display and wall mount manufacturers.
- If you have any doubts about your ability to safely install your flat panel display, contact your retailer about professional installation.
- Make sure that the wall where you are mounting the display is appropriate. Some wall mounts are not designed to be mounted to walls with steel studs or old cinder block construction. If you are unsure, contact a professional installer.
- A minimum of two people are required for installation. Flat panel displays can be heavy.



www.CEA.org/safety

Important Safety Instructions

- 1) **Read these instructions.**
 - 2) **Keep these instructions.**
 - 3) **Heed all warnings.**
 - 4) **Follow all instructions.**
-
- 5) **Do not use this apparatus near water.**
-
- 6) **Clean only with dry cloth.**
-
- 7) **Do not block any ventilation openings.** Install in accordance with the manufacturer's instructions.
-
- 8) **Do not install near any heat sources** such as radiators, heat registers, stoves, or other products (including amplifiers) that produce heat.
-
- 9) **Do not defeat the safety purpose of the polarized or grounding type plug.** A polarized plug has two blades with one wider than the other. A grounding type plug has two blades and a third grounding prong. The wide blade or the third prong are provided for your safety. If the provided plug does not fit into your outlet, consult an electrician for replacement of the obsolete outlet.

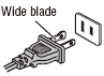

Wide blade
-
- 10) **Protect the power cord** from being walked on or pinched, particularly at plugs, convenience receptacles, and the point where they exit from the apparatus.
-
- 11) **Only use attachments/accessories specified by the manufacturer.**
-
- 12) **Use only with the cart, stand, tripod, bracket, or table specified by the manufacturer, or sold with the apparatus.** When a cart is used, use caution when moving the cart/apparatus combination to avoid injury from tip-over.

-
- 13) **Unplug this apparatus during lightning storms or when unused for long periods of time.**
-
- 14) **Refer all servicing to qualified service personnel.** Servicing is required when the apparatus has been damaged in any way, such as power-supply cord or plug is damaged, liquid has been spilled or objects have fallen into the apparatus, the apparatus has been exposed to rain or moisture, does not operate normally, or has been dropped.

Additional Safety Precautions

- 14a) **CAUTION:** If the TV is dropped and the cabinet or enclosure surface has been damaged or the TV does not operate normally, take the following precautions:
 - ALWAYS turn off the TV and unplug the power cord to avoid possible electric shock or fire.
 - NEVER allow your body to come in contact with any broken glass or liquid from the damaged television. The LCD panel inside the TV contains

glass and a toxic liquid. If the liquid comes in contact with your mouth or eyes, or your skin is cut by broken glass, rinse the affected area thoroughly with water and contact your doctor immediately.

- ALWAYS contact a service technician to inspect the TV any time it has been damaged or dropped.

15) CAUTION:

- To reduce the risk of electric shock, do not use the polarized plug with an extension cord, receptacle, or other outlet unless the blades can be inserted completely to prevent blade exposure.
- To prevent electric shock, match wide blade of plug to wide slot; fully insert.

16) CAUTION:

Do not let children swallow any small parts included on or with the product or play with the plastic bag. Keep the small parts and the plastic bag out of the reach of children.

17) CAUTION:

Do not let water or other liquids come into contact with the product, as it may result in damage.

18) WARNING:

- To prevent the spread of fire, keep candles or other open flames away from this product at all times.
- Keep the product away from direct sunlight, fire or a heat source such as a heater. This may reduce the product lifetime or result in fire.
- The mains plug is used as the disconnect device, and therefore install the LED TV/DVD combination near the wall outlet so that the mains plug can be accessed easily at all times.

Installation, Care, and Service

Installation

Follow these recommendations and precautions when installing your TV:

- 19)  **WARNING: NEVER expose the batteries to excessive heat such as sunshine, fire, or the like.**

- 20) ALWAYS plug the product into an outlet that is located in such a manner that it can be easily unplugged in case the product requires service.

- 21) NEVER route the product's power cord inside a wall or similar enclosed area.

- 22) Never modify this equipment. Changes or modifications may void: a) the warranty, and b) the user's authority to operate this equipment under the rules of the Federal Communications Commission.

23)  **DANGER: RISK OF SERIOUS PERSONAL INJURY, DEATH, OR EQUIPMENT DAMAGE!**



Never place the TV on an unstable cart, stand, or table. The TV may fall, causing serious personal injury, death, or serious damage to the TV.

- 24) When selecting a location for the TV,
- NEVER allow any part of the TV to hang over the edge of the supporting furniture,
 - NEVER place the TV on tall furniture (for example, entertainment centers or bookcases) without anchoring both the furniture and the TV to a suitable support,
 - Never place cloth or other material between the TV and the supporting furniture,
 - NEVER allow children to climb on the TV.

25) To avoid damage to this product, never place or store the TV in direct sunlight; hot, humid areas; or areas subject to excessive dust or vibration.

26) Always place the TV on the floor or a sturdy, level, stable surface that can support the weight of the unit.

27) The product shall not be exposed to dripping or splashing, and that no objects filled with liquids, such as vases, shall be placed on the apparatus.

- 28) Never block or cover the slots or openings in the TV cabinet back, bottom, and sides. Never place the TV:
- on a bed, sofa, rug, or similar surface;
 - too close to drapes, curtains, or walls; or
 - in a confined space such as a bookcase, built-in cabinet, or any other place with poor ventilation.
- The slots and openings are provided to protect the TV from overheating and to help maintain reliable operation of the TV. Leave a space of at least 4 (four) inches around the TV.

29) Always leave a space of at least 4 (four) inches around the TV. The slots and openings are provided to protect the TV from overheating and to help maintain reliable operation of the TV.

30) Never allow anything to rest on or roll over the power cord, and never place the TV where the power cord is subject to wear or abuse.

31) Never overload wall outlets and extension cords.

32) Always operate this equipment from a 120V AC, 60Hz power source.

33) Always make sure the antenna system is properly grounded to provide adequate protection against voltage surges and built-up static charges (see Section 810 of the National Electric Code).

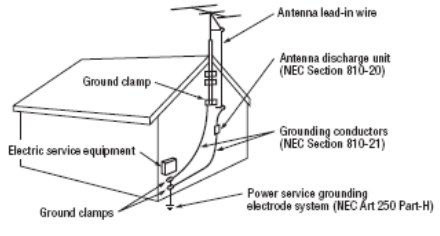

34)  **DANGER: RISK OF SERIOUS PERSONAL INJURY OR DEATH!**

- Use extreme care to make sure you are never in a position where your body (or any item you are in contact with, such as a ladder or screwdriver) can accidentally touch overhead power lines. Never locate the antenna near overhead power lines or other electrical circuits.
- Never attempt to install any of the following during lightning activity: a) an antenna system; or b) cables, wires, or any home theater component connected to an antenna or phone system.

Care

For better performance and safer operation of your TOSHIBA TV, follow these recommendations and precautions:

35) If you use the TV in a room whose temperature is 32° F (0° C) or below, the picture brightness may vary until the LCD warms up. This is not a sign of malfunction.

36)  **WARNING: RISK OF SERIOUS PERSONAL INJURY, DEATH, OR EQUIPMENT DAMAGE!**

- Never use chemicals (such as air fresheners, cleaning agents, etc.) on or near the TV pedestal. Studies indicate that plastics may weaken and crack over time from the combined effects of chemical agents and mechanical stress (such as the weight of the TV). Failure to follow these instructions could result in serious injury and/or permanent damage to TV and TV pedestal.
- Always unplug the TV before cleaning. Gently wipe the display panel surface (the TV screen) using a dry, soft cloth (cotton, flannel, etc.). A hard cloth may damage the surface of the panel. Avoid contact with alcohol, thinner, benzene, acidic or alkaline solvent cleaners, abrasive cleaners, or chemical cloths, which may damage the surface. Never spray volatile compounds such as insecticide on the cabinet. Such products may damage or discolor the cabinet.

- 37) Never hit, press, or place anything on the back cover. These actions will damage internal parts.

38)



**WARNING:
RISK OF ELECTRIC SHOCK!**



Never spill liquids or push objects of any kind into the TV cabinet slots.

- 39) During a lightning storm, do not touch the connecting cables or product.

- 40) For added protection of your TV from lightning and power surges, always unplug the power cord and disconnect the antenna from the TV if you leave the TV unattended or unused for long periods of time.

- 41) Always unplug the TV to completely disconnect from mains power. When the TV is turned off using the on/off switch, it is not completely disconnected from power and a minute amount of current is still consumed.

- 42) During normal use, the TV may make occasional snapping or popping sounds. This is normal, especially when the unit is being turned on or off. If these sounds become frequent or continuous, unplug the power cord and contact a Toshiba Authorized Service Provider.

- 43) **WARNING: RISK OF SERIOUS PERSONAL INJURY OR EQUIPMENT DAMAGE!**



Never strike the screen with a sharp or heavy object.

- 44) • The LCD screen of this product can be damaged by ultraviolet radiation from the sun. When selecting a location for the television, avoid locations where the screen may be exposed to direct sunlight, such as in front of a window.
- Never touch, press, or place anything on the LCD screen. These actions will damage the LCD screen. If you need to clean the LCD screen, follow the instructions in item 36), on page 4.

Service

45)



**WARNING:
RISK OF ELECTRIC SHOCK!**



Never attempt to service the TV yourself. Opening and removing the covers may expose you to dangerous voltage or other hazards. Failure to follow this WARNING may result in death or serious injury. Refer all servicing not specified in this manual to a Toshiba Authorized Service Provider.

- 46) If you have the TV serviced:
- Ask the service technician to use only replacement parts specified by the manufacturer.

- Upon completion of service, ask the service technician to perform routine safety checks to determine that the TV is in safe operating condition.

Choosing a location for your LED TV/DVD combination

To Display your LED TV/DVD combination on the included Pedestal Stand:

Observe the following safety precautions:

- 1) Read and follow the pedestal assembly instructions included with the pedestal.
CAUTION: Before beginning pedestal assembly, carefully lay the front of the LCD Panel face down on a flat, cushioned surface such as a quilt or blanket. Leave the bottom of the unit protruding over the edge of the surface and assemble the pedestal as indicated below.
Note: *Extreme care should always be used when attaching the pedestal stand to avoid damage to the LCD panel.*
- 2) Place the TV on a sturdy, level surface that can support the weight of the TV.
- 3) Be sure to secure the TV to a wall stud, pillar, surface, or other immovable structure. See item 26) page 4.

To Display your LED TV/DVD combination using a Wall Bracket:

If you decide to wall mount your LED TV/DVD combination, always use a wall bracket Listed by an independent laboratory (such as UL, CSA, ETL) that is appropriate for the size and weight of the TV/DVD combination:

- 1) **CAUTION:** Two people are required for installation.
- 2) Unplug and remove any cables and/or other component connectors from the rear of the TV.
- 3) Follow the instructions provided with your wall bracket. Before proceeding, make sure the appropriate bracket(s) are attached to the wall and the back of the TV as described in the instructions provided with the wall bracket.
- 4) **IMPORTANT:** Always use the screws supplied or recommended by the wall mount manufacturer.
- 5) After attaching the appropriate bracket(s) to the wall and the back of the TV, remove the pedestal stand from the TV, as described on page 6.
- 6) VESA Mounting Pattern

TV Size	Hole Pattern (HxV)	Screw Size
24V4210U	100x100 mm	M4
24V4260U	100x100 mm	M4

Removing the Pedestal Stand

- 1) Carefully lay the front of the unit face down on a flat, cushioned surface such as a quilt or blanket. Leave the stand protruding over the edge of the surface.

Note: *Extreme care should always be used when removing the pedestal stand to avoid damage to the LCD panel.*

- 2) Remove the screws shown in the below diagram. This will allow removal of the pedestal stand.
- 3) Once you have removed all of the screws holding the pedestal stand in place, remove the pedestal stand from the TV.

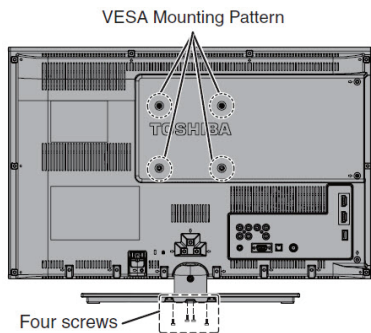

CAUTION: Always place the TV on the floor or a sturdy, level, stable surface that can support the weight of the unit.

Notes on moisture condensation

Moisture condensation damages the unit. Please read the following carefully.

Moisture condensation occurs, for example, when you pour a cold drink into a glass on a warm day and drops of water form on the outside of the glass. In the same way, moisture may condense on this unit's internal optical pick-up lens, one of the most crucial internal parts of the unit.

Moisture condensation may occur in the following situations:

- When you move the unit from a cold area to a warm area.
- When you use the unit in a room in which the heat was just turned on.
- When you use the unit in an area where cold air from an air conditioner directly hits the unit.
- When you use the unit in a humid area.

Never use the unit when moisture condensation may occur.

Using the unit when moisture condensation exists may damage discs and internal parts. Connect the power cord of the unit to the wall outlet, turn on the unit, remove the disc, and leave it for two or three hours. After two or three hours, the unit will have warmed up and evaporated any moisture. Leaving the TV connected to the wall outlet will help prevent moisture condensation in the unit.

Notes on discs

On handling discs

- Do not touch the playback side of the disc.
- Do not attach paper or tape to discs.

On cleaning discs

- Fingerprints and dust on the disc cause picture and sound deterioration. Wipe the disc from the center outwards with a soft cloth. Always keep the disc clean.
- Do not use any type of solvent such as thinner, benzene, commercially available cleaners or antistatic spray for vinyl LPs. It may damage the disc.

Structure of disc contents

Normally, DVD video discs are divided into titles, and the titles are sub-divided into chapters. Video CDs and Audio CDs are divided into tracks.

DVD

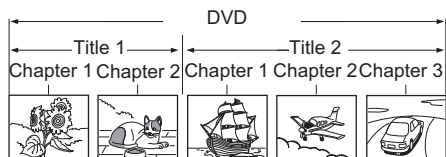

Video CD/Audio CD

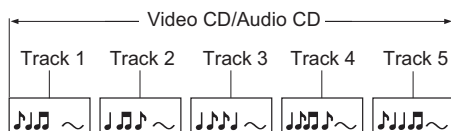

Each title, chapter or track is assigned a number, which is called "title number", "chapter number" or "track number" respectively. There may be discs that do not have these numbers

Notes on copyright

The unauthorized recording, use, distribution, or revision of copyrighted materials including, without limitation, television programs, videotapes, and DVDs, is prohibited under the Copyright Laws of the United States and other countries, and may subject you to civil and criminal liability.

About this User's Guide

This User's Guide explains the basic instructions of this LED TV/DVD combination. Some DVD video discs are produced in a manner that allows specific or limited operation during playback. As such, the LED TV/DVD combination may not respond to all operating command. This is not a defect of the LED TV/DVD combination. Refer to the instruction notes of discs. The following symbol may appear on the TV screen during operation.



It means that the operation is not permitted by the LED TV/DVD combination or the disc. For example, sometimes it is unable to stop the playback of copyright message of the disc when the Stop button is pressed. Alternatively, this symbol may also indicate that the feature is not available for the disc.

Notes on region numbers

The region number of this LED TV/DVD combination is 1. If region numbers, which stand for their playable area, are printed on your DVD and you do not find (1) or (ALL), disc playback will not be allowed by the player. (In this case, the LED TV/DVD combination will display a message on-screen.) Some DVDs that have no region code label may still be subject to area restrictions and therefore not playable.

On Video CDs

This LED TV/DVD combination supports Video CDs equipped with the Playback Control (PBC) function, version 2.0. You can enjoy two playback variations depending on types of discs.

- **Video CD not equipped with PBC function (Version 1.1)**
Sound and movie can be played on this LED TV/DVD combination in the same way as a DVD.
- **Video CD equipped with PBC function (Version 2.0)**

In addition to operation of a Video CD not equipped with the PBC function, you can enjoy playback of interactive software with search function by using the on-screen playback menu. Some of the functions described in this User's Guide may not work with some discs.

Playable discs

This LED TV/DVD combination can play the following discs.

	Disc mark	Contents	Disc size	Maximum playback time
DVD Video disc		Audio + Video (moving pictures)	12 cm	Approx. 4 hours (single sided disc) Approx. 8 hours (double sided disc)
Video CD		Audio + Video (moving pictures)	12 cm	Approx. 74 minutes (single sided disc)
Audio CD		Audio	12 cm	Approx. 74 minutes (single sided disc)

The following disc are also supported.
 -DVD-R/RW discs containing files of DVD format.
 -DVD-R/RW discs containing files of DVD video, MP3, WMA, or JPEG files.
 -Kodak Picture CD and FUJICOLOR CD.
 Some of these disc may be incompatible.

- You cannot play discs other than those listed above.
- You cannot play discs of DVD-RAM, DVD-ROM, CD-ROM, Photo CD, etc., or non-standardized discs even if they may be labeled as above.
- Some DVD-R/RWs and CD-R/RWs cannot be played back depending on the recording conditions.
- This LED TV/DVD combination uses the NTSC color system, and cannot play DVD video discs recorded in any other color system (PAL, SECAM, etc.).
- This DVD Module does not support 8cm Disc.
- Please do not insert any disc of an irregular shape into the LED TV/DVD combination, as it may interfere with the function of the LED TV/DVD combination. You may not be able to remove it.
- Please do not use after market accessories, such as a ring protector, as this may cause trouble with the operation of the LED TV/DVD combination.

Because of problems and errors that can occur during the creation of DVD and CD software and/or the manufacture of DVD and CD discs, Toshiba cannot assure that this LED TV/DVD combination will successfully play every disc bearing the DVD and CD logos. If you happen to experience any difficulty playing a DVD or CD on this LED TV/DVD combination, please contact Toshiba Customer Service.

DVD is a trademark of DVD Format/Logo Licensing Corporation.

FCC Declaration of Conformity Compliance Statement (Part 15):

The **Toshiba 24V4210U/24V4260U LED TV/DVD combinations** comply with Part 15 of the FCC rules.

Operation is subject to the following two conditions:

- (1) This device may not cause harmful interference, and
- (2) This device must accept any interference received, including interference that may cause undesired operation.

The party responsible for compliance to these rules is:

Toshiba America Information Systems, Inc.
9740 Irvine Blvd., Irvine, CA 92618.
Ph: 800-631-3811

Note: *This equipment has been tested and found to comply with the limits for a Class B digital device, pursuant to Part 15 of the FCC Rules. These limits are designed to provide reasonable protection against harmful interference in a residential installation. This equipment generates, uses, and can radiate radio frequency energy and, if not installed and used in accordance with the instructions, may cause harmful interference to radio communications. However, there is no guarantee that interference will not occur in a particular installation. If this equipment does cause harmful interference to radio or television reception, which can be determined by removing and applying power to the equipment, the user is encouraged to try to correct the interference by one of the following measures:*

- Reorient or relocate the receiving antenna.
- Increase the separation between the equipment and receiver.
- Connect the equipment into an outlet on a circuit different from that to which the receiver is connected.
- Consult the dealer or an experienced radio/TV technician for help.

Caution: *Changes or modifications to this equipment not expressly approved by Toshiba could void the user's authority to operate this equipment.*

ENERGY STAR® User Information

ENERGY STAR User Information Statement: the factory default settings of this television meet ENERGY STAR® requirements. Changing Picture Settings may increase energy consumption, possibly beyond the limits required for ENERGY STAR qualification.

To ensure your television is operating at optimal energy efficiency, select [Home] mode during initial activation. To return to [Home] mode settings, select [Standard] picture mode. [Standard] mode is recommended for normal home use.



ENERGY STAR® qualified TV. Products that earn the ENERGY STAR prevent green house gas emissions by meeting strict guidelines set by the U.S. Environmental Protection Agency. ENERGY STAR and the ENERGY STAR mark are registered U.S. marks.

Important notes about your TV/DVD combination

The following symptoms are technical limitations of LCD Display technology and are not an indication of malfunction; therefore, Toshiba is not responsible for perceived issues resulting from these symptoms.

- 1) An afterimage (ghost) may appear on the screen if a fixed, non-moving image appears for a long period of time. The afterimage is not permanent and will disappear in a short period of time.
- 2) The LCD panel contained in this TV is manufactured using an extremely high level of precision technology; however, there may be an occasional pixel (dot of light) that does not operate properly (does not light, remains constantly lit, etc.). This is a structural property of LCD technology, is not a sign of malfunction, and is not covered under your warranty. Such pixels are not visible when the picture is viewed from a normal viewing distance.

Note: Interactive video games that involve shooting a "gun" type of joystick at an on-screen target may not work with this TV.



Location of the required Marking

The rating sheet and the safety caution are on the rear of the unit.

CERTIFICATION: COMPLIES WITH FDA PERFORMANCE STANDARDS FOR LASER PRODUCTS EXCEPT FOR DEVIATIONS PURSUANT TO LASER NOTICE NO.50, DATED JUNE 24, 2007.

CAUTIONS:

- THIS LCD TV / DVD COMBINATION EMPLOYS A LASER SYSTEM.
- TO ENSURE PROPER USE OF THIS PRODUCT, PLEASE READ THIS OWNER'S MANUAL CAREFULLY AND RETAIN IT FOR FUTURE REFERENCE.
- SHOULD THE UNIT REQUIRE MAINTENANCE, CONTACT AN AUTHORIZED SERVICE LOCATION.
- USE OF CONTROLS, ADJUSTMENTS OR THE PERFORMANCE OF PROCEDURES OTHER THAN THOSE SPECIFIED HEREIN MAY RESULT IN HAZARDOUS RADIATION EXPOSURE.
- TO PREVENT DIRECT EXPOSURE TO LASER BEAM, NEVER OPEN THE ENCLOSURE. VISIBLE LASER RADIATION MAY BE PRESENT WHEN THE ENCLOSURE IS OPENED. NEVER STARE INTO THE BEAM.

Trademark Information

- CableClear, ColorStream, DynaLight, GameTimer, SurfLock are trademarks or registered trademarks of Toshiba America Information Systems, Inc. and/or Toshiba Corporation.



- Audyssey EQ[®] provides clear, accurate, and natural sound right out of the box. This technology ensures you enjoy your audio experience as much as your video.



- Audyssey ABX[™] technology uses sophisticated driver analysis and low frequency monitoring to extend the range and bass of small speakers. This enables the system to produce lower frequencies than otherwise would be possible.



- Audyssey Dynamic Volume[®] automatically adjusts volume to provide a consistent sound level between television programs, commercials, and between the loud and soft passages of movies.



- Manufactured under license from Audyssey Laboratories, Inc. U.S. and foreign patents pending. Audyssey EQ[®], Audyssey ABX[™], Audyssey Premium Television[™], and Audyssey Dynamic Volume[®] are registered and licensed trademarks of Audyssey Laboratories, Inc.



- Manufactured under license from Dolby Laboratories. Dolby and the double-D symbol are trademarks of Dolby Laboratories.

- HDMI, the HDMI Logo, and High-Definition Multimedia Interface are trademarks or registered trademarks of HDMI Licensing LLC in the United States and other countries.
- MPEG Layer-3 audio coding technology licensed from Fraunhofer IIS and Thomson.
- This production contains Bitstream Vera Sans fonts under the following copyright: Copyright © 2003 by Bitstream, Inc. All Rights Reserved. Bitstream Vera is a trademark of Bitstream, Inc.

Copyright

This guide is copyrighted by Toshiba America Information Systems, Inc. with all rights reserved. Under the copyright laws, this guide cannot be reproduced in any form without the prior written permission of Toshiba. No patent liability is assumed, however, with respect to the use of the information contained herein.

©2012 by Toshiba America Information Systems, Inc. All rights reserved.

Notice

The information contained in this manual, including but not limited to any product specifications, is subject to change without notice.

TOSHIBA CORPORATION AND TOSHIBA AMERICA INFORMATION SYSTEMS, INC. (TOSHIBA) PROVIDES NO WARRANTY WITH REGARD TO THIS MANUAL OR ANY OTHER INFORMATION CONTAINED HEREIN AND HEREBY EXPRESSLY DISCLAIMS ANY IMPLIED WARRANTIES OF MERCHANTABILITY OR FITNESS FOR ANY PARTICULAR PURPOSE WITH REGARD TO ANY OF THE FOREGOING. TOSHIBA ASSUMES NO LIABILITY FOR ANY DAMAGES INCURRED DIRECTLY OR INDIRECTLY FROM ANY TECHNICAL OR TYPOGRAPHICAL ERRORS OR OMISSIONS CONTAINED HEREIN OR FOR DISCREPANCIES BETWEEN THE PRODUCT AND THE MANUAL. IN NO EVENT SHALL TOSHIBA BE LIABLE FOR ANY INCIDENTAL, CONSEQUENTIAL, SPECIAL, OR EXEMPLARY DAMAGES, WHETHER BASED ON TORT, CONTRACT OR OTHERWISE, ARISING OUT OF OR IN CONNECTION WITH THIS MANUAL OR ANY OTHER INFORMATION CONTAINED HEREIN OR THE USE THEREOF.

Contents

Chapter 1: Introduction.....	18
Features	18
Overview of installation, setup, and use.....	19
TV front, top, and side panel controls and connections 20	
Adjusting the screen angle.....	22
TV back panel connections	22
Chapter 2: Connecting Your TV.....	24
Overview of cable types	24
Coaxial cable (F-type)	24
Standard A/V cables (red/white/yellow)	25
Component video cables (red/green/blue)	25
HDMI® cable	25
Optical audio cable.....	26
Analog RGB (15-pin) computer cable	26
3.5mm Stereo to RCA Y-cable	26
About the connection illustrations	26
Connecting a VCR, antenna, or cable TV.....	27
Connecting a camcorder	28

Connecting a DVD player with ColorStream® (component video).....	29
Connecting a satellite receiver.....	30
Connecting an HDMI® or DVI device to the HDMI® input	31
HDMI® CEC connection	34
Connecting a digital audio system	35
Connecting a computer.....	37
Connecting a computer to the TV's PC IN terminal 37	
Connection to the TV's HDMI® terminal.....	39
Chapter 3: Using the Remote Control.....	40
Using the remote control	40
Installing batteries	40
Learning about the remote control.....	42
Chapter 4: Menu Layout and Navigation	46
Main menu layout	46
Menu setup/installation/layout	47
Navigating the menu system.....	48
Chapter 5: Setting up your TV.....	50
Initial Setup.....	50
Storing channels in memory (optional).....	52
Auto Tuning	52
Setting channel skip.....	54
Setting the HDMI® audio mode.....	55
Viewing the Digital Signal Meter	57
Setting the time zone	57
Viewing the system status	58
Reset Factory Defaults	58
Chapter 6: Using the TV's features	59
Selecting the video input source	59
Labeling the video input sources	61
Tuning channels using the Channel Browser	63

Favorites browser	64
Elements of the Channel Browser	65
Adding and clearing channels and inputs in the History List	67
Tuning channels.....	67
Tuning to a specific channel (programmed or unprogrammed).....	67
Tuning to the next programmed channel	68
Switching between two channels using Channel Return.....	68
Switching between two channels using SurfLock™	68
Selecting the picture size	69
Full	70
TheaterWide 1	71
TheaterWide 2.....	71
TheaterWide 3.....	71
Native.....	72
4:3	72
Normal	73
Dot by Dot.....	73
Scrolling the TheaterWide® picture (TheaterWide 2 and 3 only).....	73
Using the Auto Aspect feature.....	74
Selecting the cinema mode.....	75
Using the FREEZE feature	75
Adjusting the picture	76
Selecting the picture mode	76
Adjusting the picture quality	77
Using closed captions.....	78
Digital CC settings.....	80
CC Selector	80
Adjusting the audio	81
Muting the sound.....	81
Using the digital audio selector.....	82
Selecting stereo/SAP broadcasts	82

Adjusting the audio quality.....	83
Audyssey Premium Television™	84
Audyssey ABX™	84
Using Audyssey Dynamic Volume®	85
Selecting the optical audio output format	85
Using the Dolby® Digital Dynamic Range Control feature.....	85
Using the Locks menu	86
Entering the PIN code	86
Forgotten PIN code	87
Changing your PIN code	87
Using parental controls (for USA region).....	88
Blocking TV programs and movies by rating (V- Chip)	88
Downloading an additional rating system	89
Displaying ratings	92
Blocking TV programs by Canada rating	92
Unlocking programs temporarily	93
Using the input lock feature	94
Locking channels	94
Using the GameTimer®	95
Using the panel lock feature.....	96
Using the PC settings feature.....	97
Setting the PC Audio	98
Using the Media Player	99
Auto Start function.....	100
To open the Media Player	100
Viewing photo files	101
Single view.....	102
Slide show	103
Playing music files.....	103
Viewing photo files and playing music files at the same time	104
Setting the sleep timer	106
Automatic Power Down	107
No Signal Power Down	108

Using HDMI® CEC.....	108
Displaying TV status information.....	112
Understanding the auto power off feature.....	113
Understanding the last mode memory feature.....	113
Chapter 7: Using the TV's Advanced Features.....	114
Using the advanced picture settings.....	114
Dynamic Contrast.....	114
Static Gamma.....	115
Color temperature.....	115
CableClear® digital Noise Reduction.....	116
MPEG Noise Reduction.....	117
Using the Game Mode feature.....	117
Chapter 8: Basic Disc Playback.....	119
Disc playback.....	119
Basic playback (DVD/VCD/CD).....	119
Removing a disc.....	121
Disc playback reminders.....	121
Playback navigation.....	122
Playing in fast reverse or fast forward direction (DVD/VCD/CD).....	122
Playing frame by frame (DVD/VCD).....	123
Playing in slow motion (DVD/VCD).....	123
Locating a chapter or track (DVD/VCD/CD).....	123
Chapter 9: Advanced Disc Playback.....	124
Zoom function/Scene navigation.....	124
Using Zoom (DVD/VCD).....	124
Locating a specific scene.....	125
Scene bookmark.....	126
Bookmarking a scene (DVD/VCD).....	127
Viewing a scene bookmark (DVD/VCD).....	128
Repeat playback/A-B repeat.....	128
Enabling repeat playback (DVD/VCD).....	128
Enabling A-B repeat mode (DVD/VCD/CD).....	129
Scene angle/Title selection/DVD menu.....	130

Changing the scene angle (DVD)	130
Selecting a DVD title (DVD).....	130
DVD menu (DVD).....	130
Sound track language/Audio channel/Subtitle.....	131
Selecting a sound track language (DVD).....	131
Selecting the audio channel (VCD).....	131
Viewing subtitles (DVD).....	131
Playback information/VCD playback control	132
Viewing the playback info (DVD/VCD).....	132
Enabling the Playback Control (PBC) function (VCD).....	132
MP3, WMA, JPEG, and Audio CD operation.....	133
MP3/WMA/JPEG/Audio CD information.....	133
About the file browser.....	135
Playing an audio file.....	136
Viewing a JPEG file	137
Viewing a slide show	138
MP3, WMA, JPEG, and Audio CD playback modes	139
Enabling repeat playback	139
Programming the playback sequence	140
Customizing disc playback.....	141
Configuring the disc playback settings (DVD/VCD/CD).....	141
Disc playback setup	143
Chapter 10: Troubleshooting.....	147
General troubleshooting.....	147
Picture problems	148
Sound problems	149
Remote control problems	150
Channel tuning problems.....	150
Closed caption problems	151
Rating blocking (V-Chip) problems.....	151
No HDMI® CEC operation	151
HDMI® problems	151

Media Player problems	152
Disc playback problems	152
light indicator	153
Power indicator	153
If the problem persists after trying the solutions ..	153
Appendix A: Specifications.....	154
Television system	154
Channel coverage.....	154
Power source	155
Power maximum current	155
Power consumption.....	155
Audio power.....	155
Speaker type	155
Video/audio terminals	155
Video/audio input.....	155
ColorStream® (component video) HD input...	156
HDMI® input	157
Digital audio output.....	157
PC input	157
DVD/CD player	157
Dimensions	157
Mass (weight)	157
Operating conditions.....	157
Supplied accessories	158
Acceptable signal formats for PC IN, HDMI®	158
PC IN signal formats	158
HDMI® signal formats.....	158
Appendix B: License Agreement	160
Index.....	164

Chapter 1

Introduction

Features

The following are just a few of the many exciting features of your new Toshiba wide screen, integrated HD, LED TV/DVD combination:

- ❖ **Integrated Digital Tuning (8VSB ATSC and QAM)**—Eliminates the need for a separate digital converter set-top box (in most cases).
- ❖ **1920 x 1080 output resolution.**
- ❖ **Two HDMI[®]**—Digital, High-Definition Multimedia Interfaces with 1080p input support, see [“Connecting an HDMI[®] or DVI device to the HDMI[®] input”](#) on page 31.
- ❖ **ColorStream[®] HD**—High-resolution component video input, see [“Connecting a DVD player with ColorStream[®] \(component video\)”](#) on page 29.
- ❖ **Digital Audio Out**—Optical audio connection with Dolby[®] Digital optical output form, see [“Connecting a digital audio system”](#) on page 35.
- ❖ **CableClear[®]**—Digital picture Noise Reduction, see [“CableClear[®] digital Noise Reduction”](#) on page 116.
- ❖ **PC IN (Analog RGB)**—Computer terminal, see [“Connecting a computer to the TV’s PC IN terminal”](#) on page 37.

- ❖ **HDMI® CEC**—Allows control of external devices from the TV remote via HDMI® connection, see [“Using HDMI® CEC” on page 108](#).
- ❖ **Media Player**—Allows you to view photo files and play music, see [“Using the Media Player” on page 99](#).
- ❖ **ENERGY STAR® qualified.**



Overview of installation, setup, and use

Follow these steps to configure your TV and begin using its many exciting features.

Carefully read the important safety, installation, care, and service information. Keep this manual for future reference.

- 1 To choose a location for the TV:
 - ❖ Read [“Important notes about your TV/DVD combination” on page 9](#).
 - ❖ Place the TV on the floor or a sturdy, level, stable surface that can support the weight of the unit. Secure the TV to a wall, pillar, or other immovable structure, see [“To avoid damage to this product, never place or store the TV in direct sunlight; hot, humid areas; or areas subject to excessive dust or vibration.” on page 4](#).
 - ❖ Place the TV in a location where light does not reflect on the screen.
 - ❖ Place the TV far enough from walls and other objects to allow proper ventilation. Inadequate ventilation may cause overheating, which will damage the TV. THIS TYPE OF DAMAGE IS NOT COVERED UNDER THE TOSHIBA WARRANTY.
- 2 Do not plug in any power cords until after you have connected all cables and devices to your TV.
- 3 Before connecting cables or devices to the TV, learn the functions of the TV’s connections and controls, see [“Overview of cable types” on page 24](#).
- 4 Connect your other electronic device(s) to the TV, see [“Connecting an HDMI® or DVI device to the HDMI® input” on page 31](#).
- 5 Install the batteries in the remote control, see [“Installing batteries” on page 40](#).

- 6 See “[Learning about the remote control](#)” on page 42 for an overview of the buttons on the remote control.
- 7 After connecting all cables and devices, plug in the power cords for your TV and other devices. Then press the Power button on the TV control panel or remote control to turn on the TV. If the TV stops responding to the controls on the remote control or TV control panel and you cannot turn the TV off or on, unplug the power cords for a few seconds and then plug them in and try again.
- 8 See “[Navigating the menu system](#)” on page 48 for a quick overview of navigating the TV’s menu system.
- 9 Program channels into the TV’s channel memory “[Auto Tuning](#)” on page 52.
- 10 For details on using the TV’s features, see chapters 8 and 9.
- 11 For details on disc playback, see chapters 8 and 9.
- 12 For help, refer to “[Troubleshooting](#)” on page 147.
- 13 For technical specifications and warranty information, see “[Specifications](#)” on page 154.
- 14 For the End User License Agreement, see “[License Agreement](#)” on page 160.

TV front, top, and side panel controls and connections

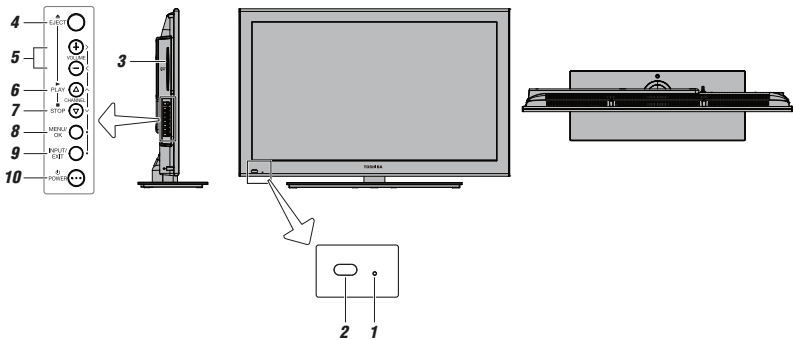

(Sample Illustration) Front and side panel controls and connections

- 1 **Power On/Standby LED**—Power indicator light, (glows green when the TV power is On).

- 2 Remote sensor (embedded)**—Point the remote control toward this remote sensor.
- 3 Disc slot**—Load the disc, with label facing forward, into the disc slot to view or listen.
- 4 EJECT button**—Press to eject the disc.
- 5 VOLUME (+ -) buttons**—Adjusts the volume level. When an on-screen menu appears, these buttons function as (◀/▶) menu navigation buttons.
- 6 Play (▶)/Channel (▲) arrow) buttons**—Plays the disc in DVD mode; changes the channel when in TV mode.
(▲) arrow button—When an on-screen menu appears, the button functions as an up menu navigation button.
- 7 Stop (■)/Channel (▼ arrow) buttons**—Stops the disc playback in DVD mode; changes the channel when in TV mode.
(▼ arrow) button—When an on-screen menu appears, the button functions as an up menu navigation button.
- 8 MENU/OK**—Accesses the menu. When an on-screen menu appears, the **MENU** button on the TV's control panel functions as the **OK** button.
- 9 INPUT/EXIT**—Changes the source you are viewing. When an on-screen menu appears, the **INPUT** button on the TV's control panel functions as the **EXIT** button.
- 10 POWER**—Turns the TV **On** and **Off**. If the TV stops responding to the controls on the remote control or TV control panel and you cannot turn off the TV, press and hold the **POWER** button on the TV control panel for few seconds to reset the TV.

Adjusting the screen angle

You can adjust the angle of the TV screen 3° forward or 15° backward from a vertical angle. Hold the base of the TV while adjusting the screen. (This feature is available on select models.)

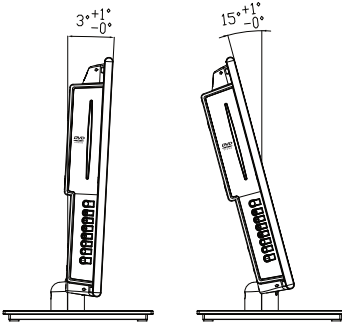

(Sample Illustration) Adjusting the screen angle

TV back panel connections

For explanations of cable types and connections, see “[Overview of cable types](#)” on page 24.

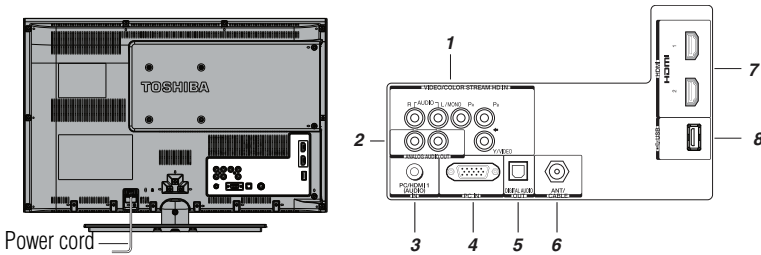

(Sample Illustration) Back panel connections

- 1 ColorStream® HD**—High-resolution component video input and shared composite video input, see “[Connecting a DVD player with ColorStream® \(component video\)](#)” on page 29.

NOTE

Component/Standard (composite) video cables carry only video information; separate audio cables are required for a complete connection.

- 2 ANALOG AUDIO OUT**—Analog audio outputs for connecting an audio amplifier.
- 3 PC/HDMI 1 (Audio) IN**—PC audio input terminal is shared with an HDMI 1 analog audio input terminal, and its use can be configured in the Audio Setup menu, see [“Setting the PC Audio” on page 98](#).
- 4 PC IN**—Connects a personal computer.
- 5 DIGITAL AUDIO OUT**—Optical audio output in Dolby® Digital or PCM (pulse-code modulation) format for connecting an external Dolby Digital decoder, amplifier, or home theater system with optical audio input.
- 6 ANT/CABLE**—Antenna input that supports analog (NTSC) and digital (ATSC) off-air antenna signals and analog and digital Cable TV (QAM) signals.
- 7 HDMI IN**—High-Definition Multimedia Interface input receives digital audio and uncompressed digital video from an HDMI® device or uncompressed digital video from a DVI device. HDMI® connection is necessary to receive 1080p signals.
- 8 USB port**—Used to access JPEG or MP3 files, or to update the TV’s firmware.

Chapter 2

Connecting Your TV

Overview of cable types

Before purchasing cables, know the connector types your devices require. You can purchase cables from most stores that sell audio/video devices.

Coaxial cable (F-type)



(Sample Illustration) Coaxial cable

Coaxial (F-type) cable connects your antenna, cable TV service, and/or cable converter box to the **ANT/CABLE** input on your TV.

Standard A/V cables (red/white/yellow)

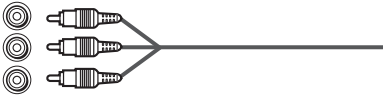

(Sample Illustration) Standard AV cables

Standard A/V cables (composite video) usually come in sets of three, and connects with video devices with analog audio and composite video output. These cables (and the related inputs on your TV) are typically color-coded according to use: yellow for video, red for stereo right audio, and white for stereo left (or mono) audio.

Component video cables (red/green/blue)

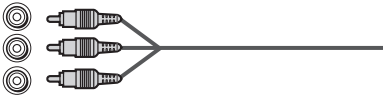

(Sample Illustration) Component video cables

Component video cables come in sets of three and connects video devices with component video output. (ColorStream® is Toshiba's brand of component video.) These cables are typically color-coded red, green, and blue. Separate audio cables are required for a complete connection.

NOTE Component video cables provide better picture quality than composite video cables.

HDMI® cable



(Sample Illustration) HDMI® cable

Use an HDMI® (High-Definition Multimedia Interface) cable with devices that have HDMI® output. An HDMI® cable delivers digital audio and video in its native format. Separate audio cables are not required, see [“Connecting an HDMI® or DVI device to the HDMI® input”](#) on page 31.

NOTE HDMI® cables provide the best audio and picture quality.

Optical audio cable



(Sample Illustration) Optical audio cable

Optical audio cable connects receivers with Dolby® Digital or PCM (pulse-code modulation) optical audio input to the TV's **Digital Audio Out** terminal, see “[Connecting a digital audio system](#)” on page 35.

Analog RGB (15-pin) computer cable

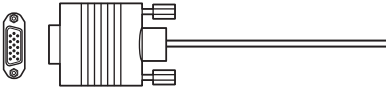

(Sample Illustration) Analog RGB (15-pin) computer cable

Analog RGB (15-pin) computer cable connects a computer to the TV's **PC IN** terminal, see “[Connecting a computer](#)” on page 37.

NOTE Separate audio cables are required.

3.5mm Stereo to RCA Y-cable



(Sample Illustration) 3.5mm Stereo to RCA Y-cable

3.5mm Stereo to RCA Y-cable connects an audio signal from DVI device to TV.

About the connection illustrations

You can connect different types and brands of devices to your TV in several different configurations. The connection illustrations in this manual are representative of typical device connections only. The input/output terminals on your devices may differ from those illustrated herein. For details on connecting and using your specific devices, refer to each device's User's Guide.

Connecting a VCR, antenna, or cable TV

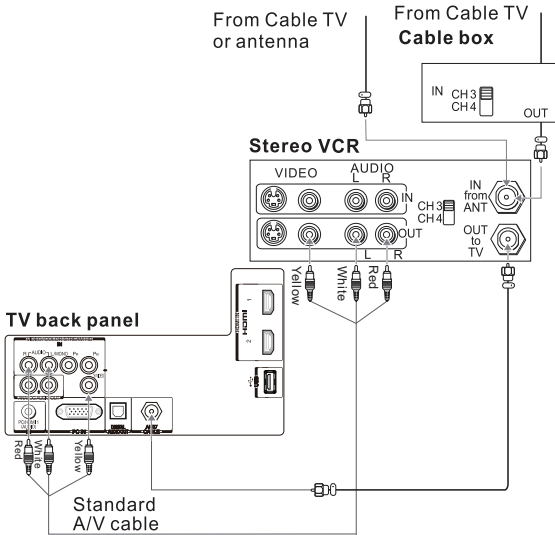

(Sample Illustration) Connecting to a VCR, antenna, or Cable TV

Items needed:

- ❖ Coaxial cables
- ❖ Standard AV cables

NOTE

When you use a Cable box, you may not be able to use the remote control to program or access certain features on the TV.

To view the antenna or cable signal:

Select **ANT/CABLE** video input source on the TV.*

To view basic and premium cable channels:

Turn **OFF** the VCR. Select the **ANT/CABLE** video input source on the TV.* Tune the TV to channel 3 or 4 (whichever channel the Cable box output is set to). Use the Cable box controls to change channels.

To view the VCR or camcorder video:

Turn **ON** the VCR or camcorder video. Select **VIDEO** input source on the TV.*

*To select the video input source, press the **INPUT** button on the remote control, see “[Selecting the video input source](#)” on page 59. To program the TV remote control to operate other devices, see “[Learning about the remote control](#)” on page 42.

Connecting a camcorder

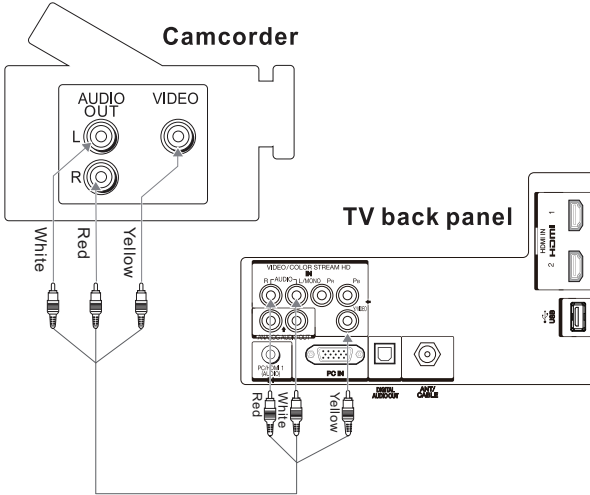

(Sample Illustration) Connecting a camcorder

You will need standard A/V cables.

To view the camcorder video, select the **VIDEO** input source on the TV.*

*To select the video input source, press the **INPUT** button on the remote control, see “[Selecting the video input source](#)” on page 59.

NOTE

The unauthorized recording, use, distribution, or revision of television programs, videotapes, DVDs, and other materials is prohibited under the Copyright Laws of the United States and other countries, and may subject you to civil and criminal liability.

Connecting a DVD player with ColorStream® (component video)

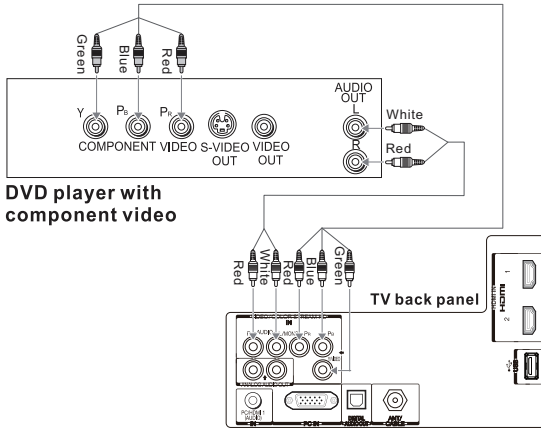

(Sample Illustration) Connecting a DVD player with ColorStream®

Items needed:

- ❖ Standard audio cables
- ❖ Component video cables
 - ❖ You can connect the component video cables (plus audio cables) from the DVD player to the **COLOR STREAM HD** terminal in the TV. The **COLOR STREAM HD** terminal can be used to display Progressive (480p, 720p) and Interlaced (480i, 1080i). Please note that 1080p is not supported. Check the User's Guide of the DVD player in order to determine the best output signal available.
 - ❖ If your DVD player does not have component video, connect a standard A/V cable to the **AUDIO/VIDEO** terminal. If your DVD player has HDMI® video, see [“Overview of installation, setup, and use” on page 19.](#)

To view the DVD player:

Turn ON the DVD player. Select the **ColorStream® HD video** input source on the TV.*

*To select the video input source, press the **INPUT** button on the remote control, see [“Selecting the video input source” on page 59.](#)

Connecting a satellite receiver

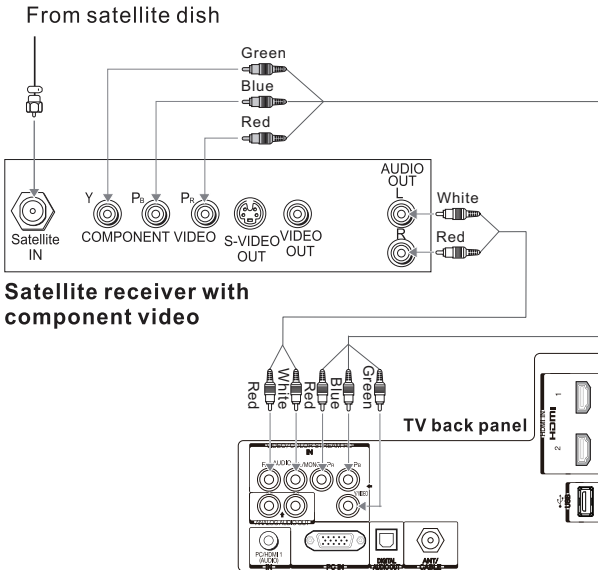

(Sample Illustration) Connecting a satellite receiver

Items needed:

- ❖ Standard audio cables
- ❖ Component video cables
 - ❖ You can connect the component video cables (plus audio cables) from the DVD player to the **COLOR STREAM HD** terminal in the TV. The **COLOR STREAM HD** terminal can be used to display Progressive (480p, 720p) and Interlaced (480i, 1080i). Please note that 1080p is not supported. Check the User's Guide of the DVD player in order to determine the best output signal available.
 - ❖ If your satellite receiver does not have component video, connect a standard A/V cable to the **AUDIO/VIDEO** terminal.

To view satellite programs using the component video connections:

Turn ON the satellite receiver. Select the **ColorStream® HD** video input source on the TV.*

*To select the video input source, press the **INPUT** button on the remote control, see “[Selecting the video input source](#)” on page 59.

NOTE The unauthorized recording, use, distribution, or revision of television programs, videotapes, DVDs, and other materials is prohibited under the Copyright Laws of the United States and other countries, and may subject you to civil and criminal liability.

Connecting an HDMI® or DVI device to the HDMI® input

The HDMI® input on your TV receives digital audio and uncompressed digital video from an HDMI® source device, or uncompressed digital video from a DVI (Digital Visual Interface) source device.

This input is designed to accept HDCP (High-Bandwidth Digital-Content Protection) program material in digital form from EIA/CEA-861-D-compliant consumer electronic devices (such as a set-top box or DVD player with HDMI® or DVI output).

The HDMI® input can accept and display VGA, SVGA, XGA, WXGA, SXGA, 480i (60Hz), 480p (60Hz), 720p (60Hz), 1080i (60Hz), and 1080p (24Hz/60Hz) signal formats. For detailed signal specifications, see “[HDMI® signal formats](#)” on page 158.

Supported Audio format: Linear PCM, sampling rate 32/44.1/ 48 kHz.

NOTE To connect a computer to the HDMI® input, see “[Connection to the TV's HDMI® terminal](#)” on page 39.

To connect an HDMI® device, you will need one HDMI® cable (type A connector) per HDMI® device.

- ❖ For proper operation, it is recommended that you use an HDMI® cable with the HDMI® Logo (**HDMI**).
- ❖ To display an 1080i/60Hz signal format, you will need a High Speed HDMI® cable. A conventional HDMI®/DVI cable may not work properly.

- ❖ HDMI® cables transfer both video and audio. Separate analog audio cables are not required (see illustration).

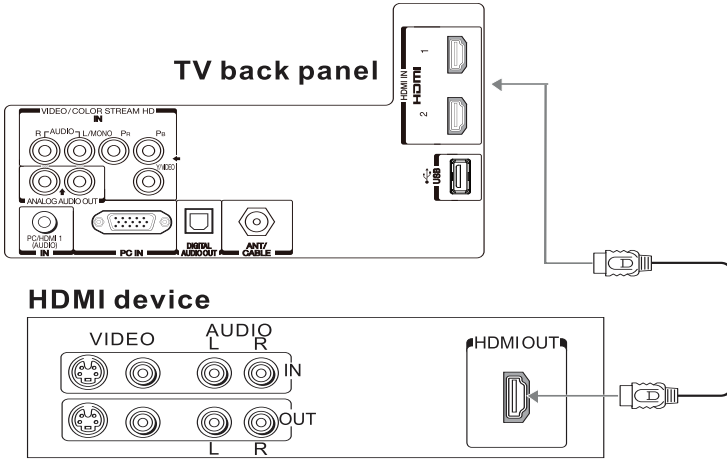

(Sample Illustration) Connecting an HDMI® device

To view the HDMI® device video:

Select **HDMI 1** or **HDMI 2** video input source on the TV.*

*To select the video input source, press the **INPUT** button on the remote control, see [“Selecting the video input source”](#) on page 59.

To connect a DVI device, you will need:

- ❖ **HDMI® to DVI adapter cable**
For proper operation, the length of an HDMI® to DVI adapter cable should not exceed 9.8 ft (3m). The recommended length is 6.6 ft (2m).

Connecting an HDMI® or DVI device to the HDMI® input

- ❖ 3.5mm Stereo to RCA Y-Cable
An HDMI® to DVI adapter cable transfers video only. Separate analog audio cables are required (see illustration).

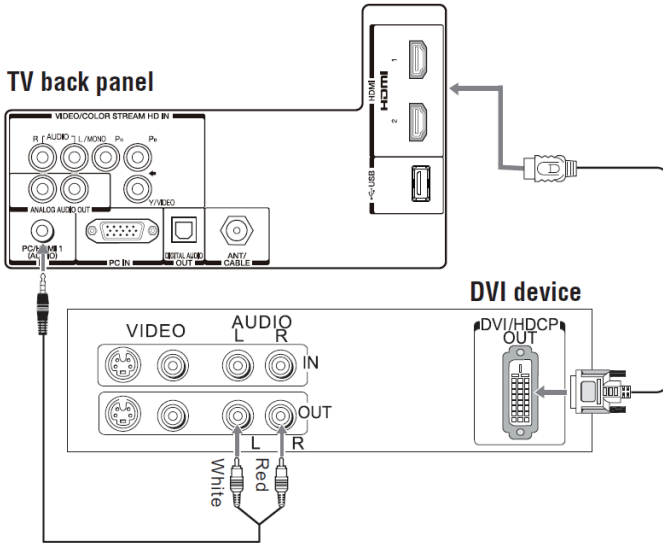
*(Sample Illustration) DVI Device connections***NOTE**

To ensure that the HDMI® or DVI device is reset properly:

- ❖ When turning on your electronic components, turn on the TV first, and then the HDMI® or DVI device.
- ❖ When turning off your electronic components, turn off the HDMI® or DVI device first, and then the TV.

NOTE

EIA/CEA-861-D compliance covers the transmission of uncompressed digital video with high-bandwidth digital content protection, which is being standardized for reception of high-definition video signals. Because this is an evolving technology, it is possible that some devices may not operate properly with the TV.

HDMI® CEC connection

You can control the basic functions of connected audio/video devices using the TV's remote control if you connect a HDMI® CEC compatible audio receiver or playback device. For an explanation of setup and operations, see “HDMI® CEC playback device (DVD player, etc.) control” on page 108. To connect an HDMI® device, you will need one HDMI® cable (type A connector) per HDMI® device.

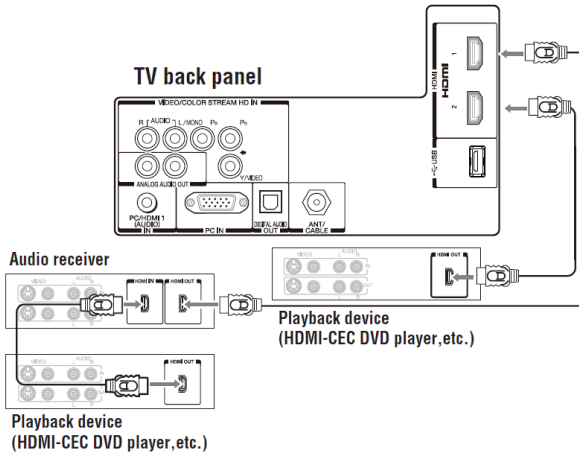

(Sample Illustration) HDMI® CEC connections

To connect an Audio Receiver and Playback Devices, you will need HDMI® cables.

- NOTE**
- ❖ If several devices are connected, HDMI® CEC feature may not operate properly.
 - ❖ For proper operation, it is recommended that you use an HDMI® cable with the HDMI® Logo (**HDMI**).

Before controlling the device(s):

- ❖ After completing the above connections, configure the HDMI® CEC Setup menu with the desired settings, see “HDMI® CEC input source selection” on page 110.
- ❖ The connected devices must also be set. For details, see the operation manual for each device.
- ❖ The HDMI® CEC feature uses the CEC technology as regulated by the HDMI® standard.

- ❖ This feature is limited to models incorporating Toshiba's HDMI® CEC. However, Toshiba is not liable for those operations. For compatibility information, refer to the individual instruction manuals for your other devices that have CEC technology.

NOTE This feature may not work properly depending on the devices that are connected.

Connecting a digital audio system

The TV's DIGITAL AUDIO OUT terminal outputs a Dolby® Digital* or 2-channel down-mixed PCM (pulse-code modulation) signal for use with an external Dolby Digital decoder or other external audio system with optical audio input.

You will need an Optical audio cable (Use an optical audio cable that has the larger "TosLink" connector and not the smaller "mini-optical" connector.)

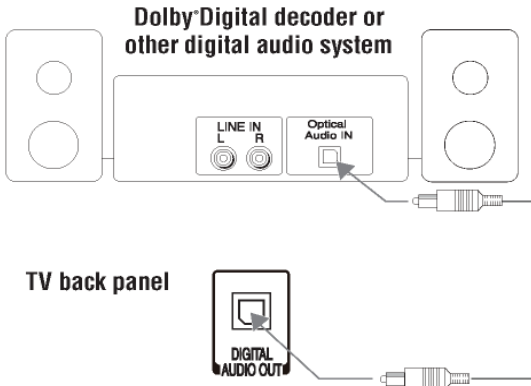

(Sample Illustration) Connecting a digital audio system

To control the audio:

- 1 Turn on the TV and the digital audio device.
- 2 Press the **MENU** button on the remote control and open the **Sound** menu.

- Press the (▲/▼ arrow) buttons to select **Audio Setup**, and then press the **INPUT** button.



(Sample Image) Audio Setup screen

- Press the (▲/▼ arrow) buttons to select **Digital Output Format**.
- Press the (◀/▶ arrow) buttons to select either **Dolby Digital** or **PCM**, depending on your device.

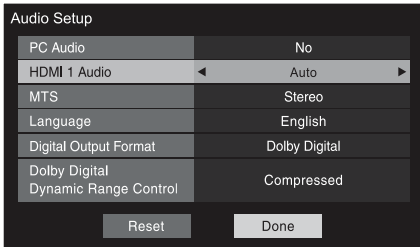

(Sample Image) Audio Setup screen - Done

- To save the new settings, highlight **Done**, and then press the **OK** button.
To revert to the factory defaults, highlight **Reset**, and then press the **OK** button.

NOTE

- ❖ Some audio systems may not be compatible with Dolby Digital bitstream signals. Older audio systems that are not compatible with standard optical out signals may not work properly, creating a high noise level that may damage speakers or headphones. **THIS DAMAGE IS NOT COVERED BY YOUR WARRANTY.**
- ❖ The DIGITAL AUDIO OUT terminal may not output some digital audio sources because of copy restrictions.

Connecting a computer

With either the PC IN or HDMI® connection, you can view your computer's display on the TV and hear the sound from the TV's speakers.

Connecting a computer to the TV's PC IN terminal

When connecting a computer to the PC IN terminal on the TV, use an analog RGB (15-pin) computer cable and a PC audio cable. For more information, see “Overview of cable types” on page 24.

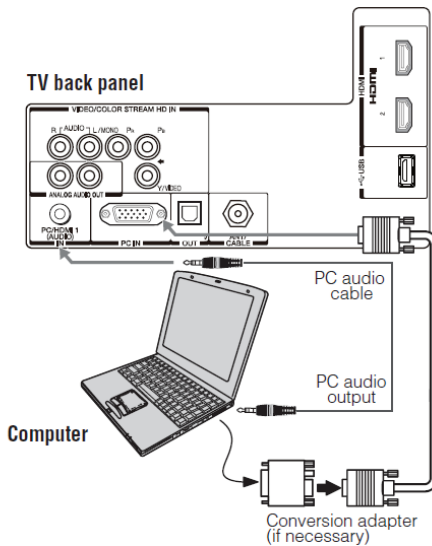

(Sample Illustration) Computer connections

To use a computer, set the monitor output resolution on the computer before connecting it to the TV. The supported signal formats are VGA, SVGA, XGA, WXGA and SXGA. For detailed signal specifications, see “Acceptable signal formats for PC IN, HDMI®” on page 158.

Other formats or non-standard signals will not be displayed correctly.

To display the optimum picture, use the computer setting feature, see [“Using the PC settings feature” on page 97](#).

- NOTE**
- ❖ The PC audio input terminals on the TV are shared with the HDMI 1 analog audio input terminals. For configuration information, see [“Setting the PC Audio” on page 98](#).
 - ❖ Some computer models cannot be connected to this TV.
 - ❖ If the computer has a compatible mini D-sub15-pin terminal, an adapter is not required.
 - ❖ Depending on the content's title and the computer's specifications, some scenes may be skipped or you may not be able to pause during multi-angle scenes.

Signal names for mini D-sub 15-pin connector:

<i>Pin No.:</i>	<i>Signal Name:</i>	<i>Pin No.:</i>	<i>Signal Name:</i>	<i>Pin No.:</i>	<i>Signal Name:</i>
1	R	6	Ground	11	Reserved
2	G	7	Ground	12	SDA
3	B	8	Ground	13	H-sync
4	Reserved	9	5V	14	V-sync
5	Ground	10	Ground	15	SCL

Connection to the TV's HDMI® terminal

When connecting a computer with a HDMI® terminal on the TV, use an adapter cable and analog audio cables.

When connecting a computer with an HDMI® port, use an HDMI® cable (type A connector). Separate analog audio cables may not be necessary, depending on computer hardware and setup.

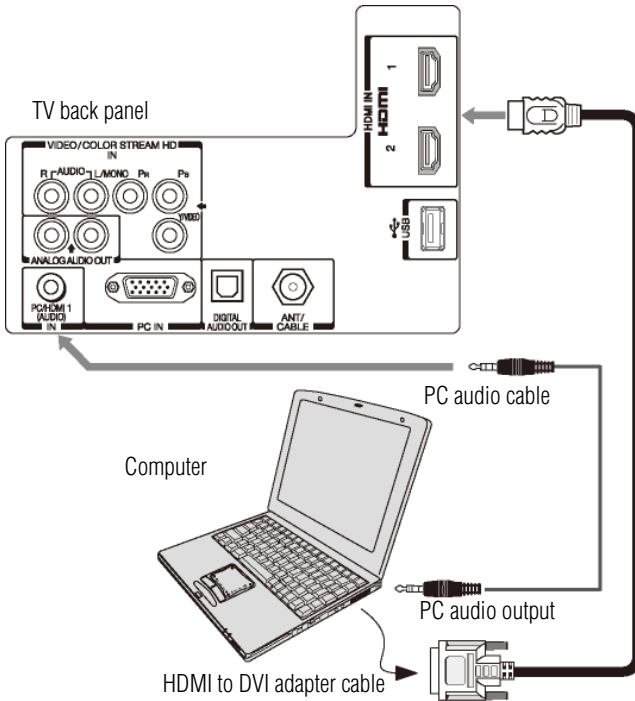

(Sample Illustration) Connections to HDMI® terminal

The supported signal formats are VGA, SVGA, XGA, WXGA, SXGA, 480i (60Hz), 480p (60Hz), 720p (60Hz), 1080i (60Hz), and 1080p (24Hz/60Hz). For signal specifications, see [“Acceptable signal formats for PC IN, HDMI®” on page 158](#).

NOTE

- ❖ The edges of the picture may be hidden.
- ❖ If receiving a 480i (HDMI®), 480p (HDMI®), 720p, 1080i, or 1080p signal program, Native mode scales the video to display the entire picture within the borders of the screen (i.e. no overscanning).

Chapter 3

Using the Remote Control

Using the remote control

The remote control can operate your LED TV/DVD combination and control the basic functions of connected audio/video devices if you connect a HDMI® CEC compatible audio receiver or playback device, see [“HDMI® CEC playback device \(DVD player, etc.\) control”](#) on page 108.

Installing batteries

To install batteries:

- 1 Open the battery lid at the bottom of remote control.

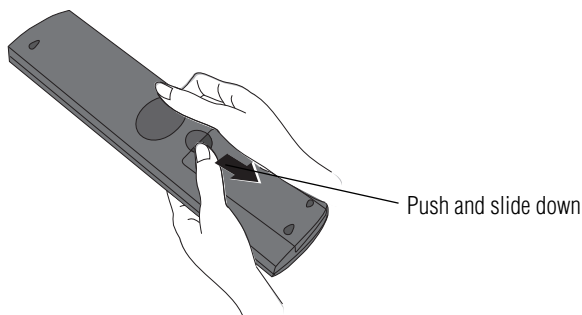

(Sample Illustration) Removing the battery cover

- 2 Insert the batteries, corresponding to the (+) and (-) markings on the battery compartment.

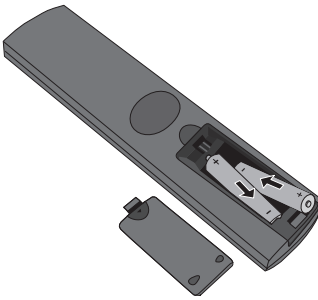

(Sample Illustration) Installing the batteries

- 3 Replace the battery cover.

CAUTION

Do not expose batteries to excessive heat such as sunshine, fire, etc.

NOTE

- ❖ Be sure to use AAA size batteries.
- ❖ Dispose of batteries in a designated disposal area.
- ❖ Always consider the environment when disposing of batteries. Always follow applicable laws and regulations.
- ❖ If the remote does not operate correctly, or if the operating range is reduced, replace the batteries.
- ❖ Always replace both batteries with new ones. Never mix battery types or use new and used batteries together.
- ❖ Always remove batteries from the remote if they are dead or if the remote control is not to be used for an extended period of time. This prevents battery acid from leaking into the battery compartment

Learning about the remote control

The buttons used for operating the LED TV/DVD combination are described here. For the HDMI® CEC remote control functions, see “HDMI® CEC playback device (DVD player, etc.) control” on page 108.

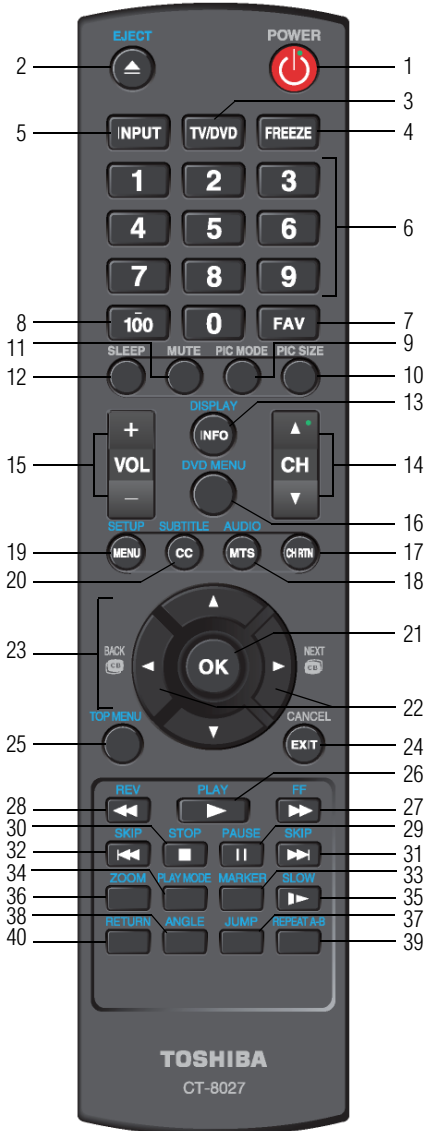

(Sample Illustration) Remote control overview

NOTE The error message "NOT AVAILABLE" may appear if you press a key for a function that is not available.

- 1 The **POWER** button turns the TV On and Off. When the TV is on, the power LED indicator on the TV front glows green.
- 2 The **EJECT** button ejects the disc from the disc slot.
- 3 The **TV/DVD** button switches between TV and DVD mode.
- 4 The **FREEZE** button freezes the picture. Press again to restore the video, see ["Using the FREEZE feature" on page 75](#).
- 5 The **INPUT** button selects the video input source, see ["Selecting the video input source" on page 59](#).
- 6 The **Channel Number** buttons directly tune channels.
- 7 The **FAV** button accesses the Favorites List in the Channel Browser, see ["Favorites browser" on page 64](#).
- 8 The **Dash/100** button allows you to enter two part channel numbers, see ["Tuning to a specific channel \(programmed or unprogrammed\)" on page 67](#) or to edit the Favorites List, see ["Favorites browser" on page 64](#).
- 9 The **PIC MODE** button selects the picture mode, see ["Selecting the picture mode" on page 76](#).
- 10 The **PIC SIZE** button cycles through the picture sizes ["Selecting the picture size" on page 69](#).
- 11 The **MUTE** button reduces or turns off the sound, see ["Muting the sound" on page 81](#).
- 12 The **SLEEP** button accesses the sleep timer, see ["Setting the sleep timer" on page 106](#).
- 13 The **DISPLAY/INFO** button displays TV status information as well as program details, when available, see ["Displaying TV status information" on page 112](#).
- 14 The **CH (▲/▼ arrow)** buttons cycle through programmed channels (when no on-screen menu is displayed), see .
- 15 The **VOL (+ -)** buttons adjust the volume level.
- 16 The **DVD MENU** button accesses the DVD menu, see ["DVD menu \(DVD\)" on page 130](#).

- 17 The **CH RTN** button returns to the last viewed channel or source, see [“Switching between two channels using Channel Return” on page 68](#); Also, the CH RTN button returns to the previous directory from a Media Player sub-folder or sub-menu, see [“Viewing photo files” on page 101](#).
- 18 The **AUDIO/MTS** button selects the audio mode in ANT/CABLE source, see [“Using the MTS button” on page 83](#); selects the DVD sound track language or VCD audio channel in DVD mode, see [“Sound track language/Audio channel/Subtitle” on page 131](#).
- 19 The **SETUP/MENU** button accesses the main TV menu system, see [“Navigating the menu system” on page 48](#); configures the disc playback settings in DVD mode, see [“Advanced Disc Playback” on page 124](#).
- 20 The **SUBTITLE/CC** button selects the subtitle language or switches subtitle off in DVD mode, see [“Viewing subtitles \(DVD\)” on page 131](#). CC: opens the closed caption selector in ANT/CABLE source.
- 21 The **OK** button activates highlighted items in the main menu system.
- 22 The (**◀/▶** arrow) buttons open the Channel Browser and tune to the previous/next channel in the channel history while watching TV, see [“Tuning channels using the Channel Browser” on page 63](#).
- 23 The **Arrow** buttons (**▲▼◀▶**) select or adjust programming menus when a menu is on-screen.
- 24 The **CANCEL/EXIT** button closes on-screen menus, or returns you to the previously view menu.
- 25 The **TOP MENU** button accesses the top menu of DVDs that contain two or more titles, see [“Disc playback” on page 119](#).
- 26 The **PLAY** button begins playback of the loaded disc, see [“Playing an audio file” on page 136](#).
- 27 The **FF** button fast-forwards playback of the disc, see [“Playing an audio file” on page 136](#).
- 28 The **REV** button fast-reverses playback of the disc, see [“Playing an audio file” on page 136](#).
- 29 The **PAUSE** button suspends disc playback temporarily or plays back disc frame by frame, see [“Playing an audio file” on page 136](#).

- 30 The **STOP** button stops playback of the loaded disc, see [“Playing an audio file” on page 136](#).
- 31 The **SKIP** forward button skips forward to locate later DVD chapters, see [“Playing an audio file” on page 136](#).
- 32 The **SKIP** reverse button skips back to locate the beginning of current DVD chapter or locate a previous chapter, see [“Playing an audio file” on page 136](#).
- 33 The **MARKER** button bookmarks specific points in the playback range for later access, see [“Bookmarking a scene \(DVD/VCD\)” on page 127](#).
- 34 The **PLAY MODE** button sets the disc playback repeat mode, see [“Disc playback” on page 119](#).
- 35 The **SLOW** button slow-forwards playback of the disc, see [“Disc playback” on page 119](#).
- 36 The **ZOOM** button zooms into the center of the image during disc playback, see [“Zoom function/Scene navigation” on page 124](#).
- 37 The **JUMP** button selects or locates a specific point within the disc playback, see [“Locating a specific scene” on page 125](#).
- 38 The **ANGLE** button changes the scene angle when playing back a DVD recorded with multi-angle scenes, see [“Changing the scene angle \(DVD\)” on page 130](#).
- 39 The **REPEAT A-B** button repeats playback of a specific section between two set points, see [“Enabling A-B repeat mode \(DVD/VCD/CD\)” on page 129](#).
- 40 The **RETURN** button returns to the root directory in audio CD playback, see [“Playing an audio file” on page 136](#).



Chapter 4



Menu Layout and Navigation

Main menu layout

The Installation menu contains the Terrestrial and System Status menus.

To open the Installation menu, press the **MENU** button on the remote control or **MENU** on the TV control panel, open the Setup menu, select Installation, and then press the **OK** button.



<i>Icon</i>	<i>Item</i>	<i>Option</i>
	Mode	Dynamic/Standard/Movie/PC/Preference
	Picture Settings	Opens the Picture Settings menu
	Noise Reduction	Opens the Noise Reduction menu
	Game Mode	Off/On
	Theater Settings	Opens the Theater Settings menu
	Digital Audio Selector	Launches the temporary Audio Selector
	Audio Settings	Opens the Audio Settings menu
	Audio Setup	Opens the Audio Setup menu

<i>Icon</i>	<i>Item</i>	<i>Option</i>
	Preferences	
	CC Selector	Launches the temporary CC Selector
	Base CC Mode	Off/CC1/CC2/CC3/CC4/T1/T2/T3/T4
	Digital CC Settings	Opens the Digital CC Settings menu
	Input Labeling	Opens the Input Labeling menu
	AV Input	Selects ColorStream® HD/Video input
	Menu Language	English/Français/Español
	Channel Browser Setup	Opens the Channel Browser Setup menu
	HDMI® CEC Player Control	Opens the HDMI® CEC Player Control menu
Energy Saving Settings	Opens the Energy Saving Settings menu	
	Locks	
	Enable Rating Blocking	Off/On
	Edit Rating Limits	Opens the Edit Rating Limits menu
	Input Lock	Off/Video/Video+
	Panel Lock	Off/On
	GameTimer®	Off/30 min/60 min/90 min/120 min
	Setup	
	Installation	Opens the Installation menu
	HDMI® CEC Setup	Opens the HDMI® CEC Setup menu
	Sleep Timer	10-minute increments, from 0 min to a maximum of 12 hours
	PC Settings	Opens the PC Settings menu
	Media Player	Opens the Media Player menu

Menu setup/installation/layout

The Installation menu contains the Terrestrial and System Status menus.

To open the Installation menu, press the **MENU** button on the remote control or **MENU** on the TV control panel, open the Setup menu, select **Installation**, and then press the **OK** button.

Icon	Item	Option
	Input Configuration	Opens the Input Configuration menu
	Channel Program	Start Scan > Scans for new channels on ANT/CABLE
	Channel Options	Opens the Skip/Lock Channel menu
	Time Zone	Eastern/Newfoundland/Atlantic/Hawaii/Alaska/Pacific/Mountain/Central
	Signal Meter	Opens the Signal Meter menu
System Status	System Information	Opens the System Information screen
		

Navigating the menu system

You can use the buttons on the remote control or TV control panel to access and navigate your TV's on-screen menu system.

- 1 Press the **MENU** button to open the menu system.

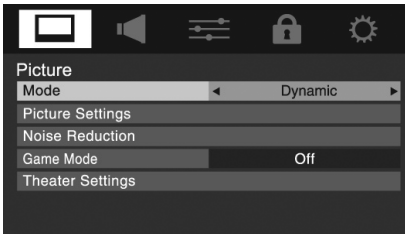

(Sample Image) Navigating the menu system

- 2 When a menu is open, use the (▲/▼/◀/▶ arrow) buttons on the remote control or the (▲/▼/◀/▶ + - arrow) buttons on the TV control panel to move in the corresponding direction in the menu.
- 3 Press the **OK** button to save your menu settings or select a highlighted item.

A highlighted menu item appears in a different color in the menu.

- 4 All menus close automatically if you do not make a selection within a few seconds, except the signal meter menu, which closes automatically after a few minutes.
 - 5 To close a menu instantly, press the **EXIT** button.
-

NOTE The menu background may sometimes appear black, depending on the signal the TV is receiving. This is not a sign of malfunction.

Chapter 5

Setting up your TV

Initial Setup

When you first turn on or reset the TV, the Initial Setup window will appear.

- 1 In the **Menu Language** field, press the (◀/▶ arrow) buttons.
- 2 Press the (◀/▶ arrow) buttons to select **Time Zone Setup** and set your desired time zone, using the (◀/▶ arrow) buttons, and then press the **OK** button.

The **Location** settings window appears.

- 3 For normal home use, press the (◀/▶ arrow) buttons to select **Home**, and then press the **OK** button.

The **ANT/CABLE In** setup window appears.

- 4 Press the (◀/▶ arrow) buttons to select the input source (**Cable** or **Antenna**), then press the **OK** button.
- 5 Press the **OK** button to select **Start Scan** and continue with the Auto Tuning.

You can stop the Initial Setup by pressing the **EXIT** button. However if you do not finish the entire Initial Setup process and press the **POWER** button before starting the auto tuning steps, the Initial Setup window will appear every time you turn on the TV.

Menu language

You can choose from three different menu language settings (English, Français, and Español). Your selection is the language all menus are displayed in.

To select the menu language:

- 1 Press the **MENU** button to open the **Preferences** menu, and highlight **Menu Language**.
- 2 Select **Settings, SETUP**, and then **Menu Language**.
- 3 Press the (◀/▶ arrow) buttons to select your preferred language.

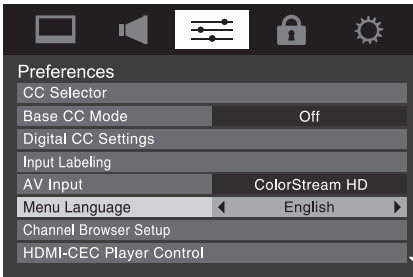

(Sample Image) Selecting the menu language

- 4 Press the **EXIT** button to close the **Preferences** menu.

ANT/CABLE IN

This setting configures the antenna input source for the ANT/CABLE terminal.

- 1 Press the **MENU** button to open the **Setup** menu.
- 2 Highlight **Installation**, and then press the **OK** button.
A new set of Installation menus appear.
- 3 Open the Terrestrial menu, highlight **Input Configuration**, and then press the **OK** button.

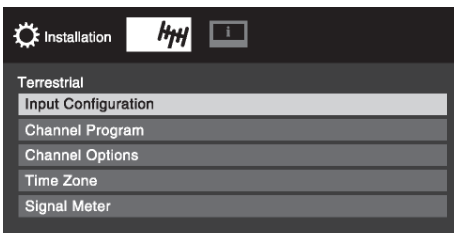

(Sample Image) Selecting the ANT/CABLE input source

- 4 Highlight **ANT/CABLE In** and press the (◀/▶ arrow) buttons to select the input source (**Cable** or **Antenna**).



(Sample Image) Selecting the ANT/CABLE input source

- 5 To save your new settings, highlight **Done**, and then press the **OK** button. To revert to your original settings, highlight **Cancel**, and then press the **OK** button.

Storing channels in memory (optional)

To make sure your TV stops only on the channels you want when you press the **CH Up/Down** arrow buttons on the remote control or the control panel, store those channels in the TV's memory.

Auto Tuning

You can configure the TV to detect all active channels in your area and store them in its memory. Then you can manually store or skip individual channels from memory.

- NOTE**
- ❖ You must configure the antenna/cable input source first.
 - ❖ The automatic channel programming process will erase channels that were previously programmed into the TV's memory.
 - ❖ To tune the TV to a channel not programmed in the channel memory, you must use the Channel Number buttons on the remote control.
 - ❖ Programming channels when the ANT/CABLE input is configured for Cable will take substantially longer than when the antenna input is configured for Antenna. This is normal; however, once channel programming is finished, you should not have to repeat the programming process again unless your Cable TV service lineup changes significantly.

To program channels automatically:

- 1 Configure the antenna input source, if you have not already done, see “**ANT/CABLE IN**” on page 51.
- 2 Press the **MENU** button to open the **Setup** menu.

- 3 Highlight **Installation**, and then press the **OK** button.

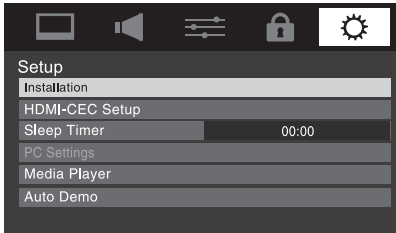

(Sample Image) Auto tuning program channels

A new set of **Installation** menus appear.

- 4 Open the **Terrestrial** menu, highlight **Channel Program** to open the **Start Scan** window, and then press the **OK** button to begin channel programming.

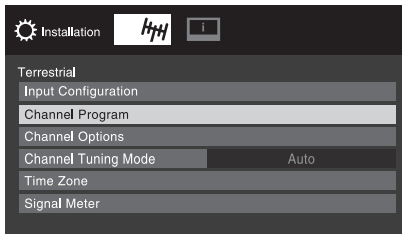

(Sample Image) Terrestrial menu - Channel Program selection

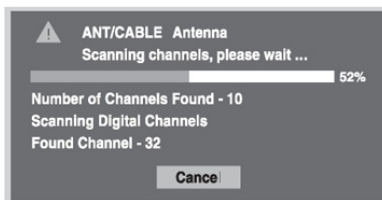

(Sample Image) Auto tuning program channels

The TV will automatically cycle through all the antenna channels, and store all active channels in the channel memory. While the TV is cycling through the channels, the message “Scanning channels, please wait” appears.

- 5 To cancel channel programming, press the **EXIT** button on the remote control or highlight **Cancel** in the on-screen display, and then press the **OK** button.

When channel programming is complete, press the **CH Up/Down** arrow buttons to view the programmed channels.

Setting channel skip

To prevent a channel from being viewed, you can set it to be skipped.

- 1 From the **Setup** menu, highlight Installation, and then press the **OK** button.
- 2 Press the (**▲/▼** arrow) buttons to select **Channel Options**, and then press the **OK** button.

The list of channels appears.

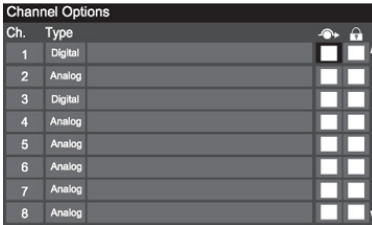

Ch.	Type	<input type="checkbox"/>	<input type="checkbox"/>
1	Digital	<input checked="" type="checkbox"/>	<input type="checkbox"/>
2	Analog	<input type="checkbox"/>	<input type="checkbox"/>
3	Digital	<input type="checkbox"/>	<input type="checkbox"/>
4	Analog	<input type="checkbox"/>	<input type="checkbox"/>
5	Analog	<input type="checkbox"/>	<input type="checkbox"/>
6	Analog	<input type="checkbox"/>	<input type="checkbox"/>
7	Analog	<input type="checkbox"/>	<input type="checkbox"/>
8	Analog	<input type="checkbox"/>	<input type="checkbox"/>

(Sample Illustration) List of channels

- 3 Press the (**▲/▼** arrow) buttons to select a channel position to be skipped, and then press the **OK** button.

To remove the check, press the **OK** button again.

To add a channel to the channel memory:

Highlight the checked box next to the channel number you wish to add, and then press the **OK** button to remove the check.

To block channels in the channel memory:

NOTE You will not be able to tune blocked channels unless you unlock them.

- 1 From the Channel Options menu, press the (**▶** arrow) button to move to the channel lock list.

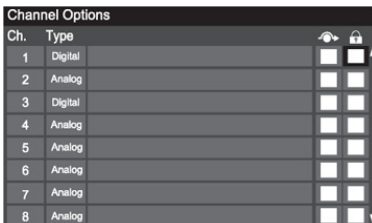

Ch.	Type	<input type="checkbox"/>	<input type="checkbox"/>
1	Digital	<input type="checkbox"/>	<input type="checkbox"/>
2	Analog	<input type="checkbox"/>	<input type="checkbox"/>
3	Digital	<input type="checkbox"/>	<input type="checkbox"/>
4	Analog	<input type="checkbox"/>	<input type="checkbox"/>
5	Analog	<input type="checkbox"/>	<input type="checkbox"/>
6	Analog	<input type="checkbox"/>	<input type="checkbox"/>
7	Analog	<input type="checkbox"/>	<input type="checkbox"/>
8	Analog	<input type="checkbox"/>	<input type="checkbox"/>

(Sample Illustration) Channel lock list

- 2 Press the (▲/▼ arrow) buttons to select a channel position to be locked, and then press the **OK** button. Enter your four-digit PIN code.

A check appears in the box. To remove the check, press the **OK** button again.

NOTE If the PIN code has not been set yet, a warning message appears.

- 3 To save the setting, press the **EXIT** button.

To manually add digital sub-channels on a physical channel:

Use the Channel Numbers and the **Dash/100** button on the remote control to enter the channel number (for example, 56–1). If the channel is found, the number will be added to the list and the box will be unchecked.

If the channel is not found, a message appears.

NOTE Skipped channels cannot be selected with the **CH Up/Down** arrow buttons; however, they can be accessed using the number keys on the remote control.

To remove encrypted channels from the channel memory:

If an encrypted channel is accidentally added to the channel list while programming channels, you can remove the unwanted encrypted (non-viewable) channel while you are channel surfing. When you tune to an encrypted channel, the following message appears.



Digital Channel Is Encrypted - Press 1 on remote to remove channel

(Sample Illustration) Removing an encrypted channel

Press the **1** button while the message is displayed to remove the unnecessary channel from the channel list.

Setting the HDMI® audio mode

To set the HDMI® audio mode:

- 1 Press the **MENU** button to open the **Sound** menu.
- 2 Highlight **Audio Setup**, and then press the **OK** button.

- 3 Press the (▲/▼ arrow) buttons to select **HDMI 1 Audio**, and then press the (◀/▶ arrow) buttons to select the HDMI 1 audio mode (**Auto**, **Digital**, or **Analog**). (**Auto** is the recommended mode.) See “Connecting an HDMI® or DVI device to the HDMI® input” on page 31.

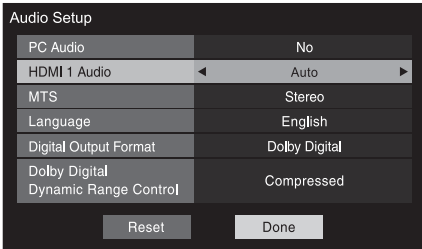

(Sample Image) HDMI® Audio mode screen

Mode:	Description:
Auto	When viewing the HDMI 1 input, if digital audio from the HDMI® input is available, it will be output. If not, the TV will automatically detect and output analog audio from the PC Audio input.
Digital	When viewing the HDMI 1 input, digital audio from the HDMI® input will be output.
Analog	When viewing the HDMI 1 input, analog audio from the PC Audio input will be output.

- 4 To save the setting, highlight **Done**, and then press the **OK** button.

NOTE Because the PC and HDMI 1 inputs share the same set of analog audio inputs, the PC Audio menu setting influences the HDMI 1 Audio menu setting. If PC Audio is set to “No” the HDMI 1 Audio setting changes to “Auto.” If PC Audio is set to “Yes” the HDMI 1 Audio setting is set to “Digital” and is grayed out in the menu. See “Setting the PC Audio” on page 98.

Viewing the Digital Signal Meter

You can view the digital signal meter in the ANT/ CABLE digital TV input source only.

To view the digital signal meter:

- 1 Press the **MENU** button to open the **Setup** menu.
- 2 Highlight **Installation**, and then press the **OK** button.
A new set of Installation menu icons appear.
- 3 Open the **Terrestrial** menu, highlight **Signal Meter**, and then press the **OK** button.
- 4 Press the (▲/▼/◀/▶ arrow) buttons to select the antenna input and digital channel signal you wish to check.
- 5 If you want detailed information of the presentation channel, Highlight **Advanced**, and then press the **OK** button.

NOTE

- ❖ The physical digital channel number listed in the Signal Meter screen may not correspond to a virtual TV channel number. Contact your local broadcasters to obtain the RF channel numbers for your local digital stations.
 - ❖ The signal strength does not change between virtual channels on the same physical channel.
-

To close the screen and return to the Installation menu:

Highlight **Done**, and then press the **OK** button.

To return to normal viewing, press the **CANCEL** button.

Setting the time zone

The Time Zone setup allows you to specify the correct time zone for your region. This feature allows the TV status information to display the correct time zone information for your viewing area.

- 1 In the **Setup** menu, highlight **Installation**, and then press the **OK** button.
- 2 Highlight **Time Zone**, and then press the **OK** button.
- 3 Press the (◀/▶ arrow) buttons to select the region, highlight **Done**, and then press the **OK** button.

After the time zone has been set, you will be asked to set the current Daylight Saving Time status.

To set the Daylight Saving Time status, press the (◀/▶ arrow) buttons to select **Yes** or **No**, highlight **Done**, and then press the **OK** button.

Viewing the system status

- 1 Press the **MENU** button to open the **Setup** menu.
- 2 Highlight **Installation**, and then press the **OK** button.
A new set of Installation menu icons appear.
- 3 Open the **System Status** menu, highlight **System Information**, and then press the **OK** button.
- 4 Press the (◀/▶ arrow) buttons to scroll through the menu bar to select **Factory Defaults** or **Support Information**.

The related information appears.

To close the screen and return to the Installation menu highlight **Done** in the Support Information screen or highlight **No** in the Factory Defaults screen, and then press the **OK** button.

To return to normal viewing, press the **CANCEL** button.

Reset Factory Defaults

- 1 Press the **MENU** button to open the **Setup** menu.
- 2 Highlight **Installation**, and then press the **OK** button.
A new set of Installation menu icons appear.
- 3 Open the **System Status** menu, highlight **System Information**, and then press the **OK** button.
- 4 Press the (◀/▶ arrow) buttons to scroll through the menu bar to select **Factory Defaults**.
- 5 Highlight **Yes**, and then press the **OK** button.
- 6 If a PIN code have been set, enter your PIN code.
- 7 Press the (◀/▶ arrow) buttons to select **Done**, and then press the **OK** button.

A warning message appears.

- 8 Select **Yes**, and then press the **OK** button.

the TV turns off automatically after a few seconds. After the TV turns off, unplug the TV power cord and then plug it in again to complete the reset process.

- 9 To cancel the reset process, select **No**, and press the **OK** button.

Chapter 6

Using the TV's features

Selecting the video input source

To select the video input source to view:

- 1 Press the **INPUT** button on the remote control or TV control panel.
- 2 Choose from the following options:
 - ❖ Press 0-5.
 - ❖ Repeatedly press the (▲/▼ arrow) buttons on the remote control, and then press the **OK** button to change the input setting.
 - ❖ Repeatedly press the **INPUT** button on the remote control or TV control panel to change the input setting.

- ❖ The current signal source displays in the top right corner of the Input Selection screen.

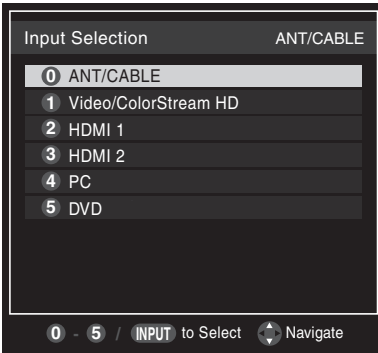

(Sample Image) Input Selection screen

NOTE

- ❖ You can label the video input sources according to the specific devices you have connected to the TV, see [“Labeling the video input sources” on page 61](#).
- ❖ Sources can be “hidden,” see [“Labeling the video input sources” on page 61](#).
- ❖ “No video signal” will appear randomly on the screen if no signal is received in video input mode.
- ❖ If CEC device is connected to an HDMI® input, the HDMI® CEC icon appears.

If a HDMI® CEC device with HDMI® switching capability (e.g. Audio Receiver) is connected to the HDMI® input, press the **INPUT** button on the remote control or TV control panel repeatedly to highlight **HDMI 1** or **HDMI 2**.

If the connected CEC device has any connected devices, a separate device selection pop-up window appears:

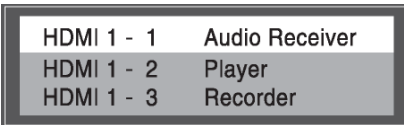

(Sample Illustration) HDMI® setting pop-up window

Press the **INPUT** button repeatedly to highlight the desired input source, and then press the **EXIT** button.

- NOTE**
- ❖ When selecting HDMI® CEC input sources from the pop-up window using the INPUT button, some HDMI® CEC devices may automatically turn on.
 - ❖ When selecting input sources using the (▲/▼ arrow) buttons, you will need to press the OK button to actually select a particular device from the pop-up window.
-

Labeling the video input sources

You can label each video input source according to the type of device you have connected to each source. Choose from the following preset list of labels:

- ❖ -- (default label)
- ❖ Audio Receiver
- ❖ Cable
- ❖ Compact Disc
- ❖ DTV
- ❖ DVD
- ❖ Game Console
- ❖ HDMI® Switch (HDMI® inputs only)
- ❖ Laser Disc
- ❖ Satellite/DSS
- ❖ VCR
- ❖ Video Recorder
- ❖ Hide (to hide an unused input in the Input Selection screen and in the Channel Browser Inputs list)

-
- NOTE** If you select PC in the Input Selection screen, you can choose only "--", "Game Console", or "Hide" as the label.
-

To label the video input sources:

- 1 Press the **MENU** button to open the **Preferences** menu.
- 2 Highlight **Input Labeling**, and then press the **OK** button.

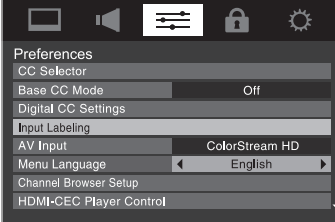

(Sample Image) Input Labeling screen

- 3 Press the (**▲/▼** arrow) buttons to highlight the video source you wish to label.
- 4 Press the (**◀/▶** arrow) buttons to select the desired label for that input source. If a particular input is not used, **Hide** can be selected as the label. This will cause that input to be “grayed out” in the Input Selection screen and skipped over when you press the **INPUT** button on the remote control.

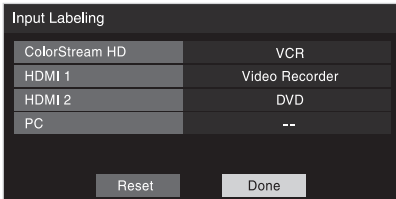

(Sample Image) Input Labeling screen - Done

- 5 To save the new input labels, highlight **Done**, and then press the **OK** button.

Input labeling example:

The screen below left shows the default Input Selection screen (with none of the inputs labeled as a specific device). The screen below (right) is an example of how you can label the inputs if you connected a VCR to ColorStream® HD, a video recorder to HDMI 1, and a DVD player to HDMI 2.

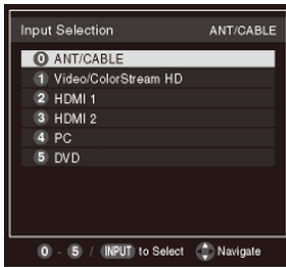

No inputs labeled

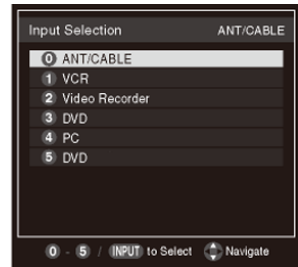

All inputs labeled

(Sample Image) Input selection screens

To clear the input labels:

- 1 Press the **MENU** button to open the **Preferences** menu.
- 2 Highlight **Input Labeling**, and then press the **OK** button.
- 3 Highlight **Reset**, and then press the **OK** button.

Tuning channels using the Channel Browser

The Channel Browser provides an easy navigation interface for all your channels and inputs. This feature allows you to:

- ❖ Navigate the contents of all of your inputs.
- ❖ Keep a list of your favorite channels, see [“Favorites browser” on page 64](#).
- ❖ Quickly surf and tune your recently viewed channels/inputs from the Channel Browser History List.
- ❖ Surf via Browse mode (to immediately tune channels as you highlight them in the Channel Browser) or Select mode (to surf over channels in the Channel Browser before you select one to tune).
- ❖ Quickly change inputs from the Inputs List.
- ❖ Quickly select HDMI® CEC devices from the HDMI® CEC List.

Favorites browser

The Favorites Browser allows you to quickly configure a favorite channels/inputs list that is integrated into the Channel Browser.

To add a favorite channel/input:

- 1 Tune to the channel or input.
- 2 Press and hold the **FAV** button for a few seconds.

NOTE The channel or input is added to the beginning of the Favorites list on the left side of the Channel Browser.

To delete a favorite channel/input:

- 1 Press the **FAV** button to open the Favorites browser list.
- 2 Highlight the channel or input to delete by pressing the **BACK CB/NEXT CB** buttons.
- 3 Press and hold the **Dash/100** button for a few seconds. The channel/input will be removed from the Favorites list.

To configure the Channel Browser:

- 1 In the Preferences menu, highlight **Channel Browser Setup**, and then press the **OK** button.
- 2 Press the (**▲** arrow) button to highlight **Navigation**, and then press the (**◀/▶** arrow) buttons to select either **Browse Mode** or **Select Mode**.

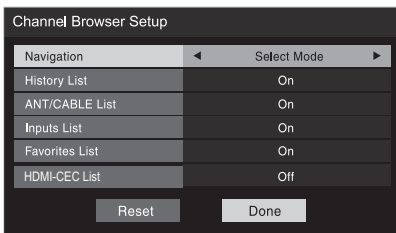

(Sample Image) Browser mode screen

- 3 Press the (**▼** arrow) button to highlight **History List**, and then press the (**◀/▶** arrow) buttons to select **On/Off**.

NOTE The History List will be cleared every time the TV is powered off.

- 4 Press the (**▼** arrow) button to highlight **ANT/CABLE List**, and then press the (**◀/▶** arrow) buttons to select **On/Off**.

Tuning channels using the Channel Browser

- 5 Press the (▼ arrow) button to highlight **Inputs List**, and then press the (◀/▶ arrow) buttons to select **On/Off**.
- 6 Press the (▼ arrow) button to highlight **Favorites List**, and then press the (◀/▶ arrow) buttons to select **On/Off**.
- 7 Press the (▼ arrow) button to highlight **HDMI® CEC List**, and then press the (◀/▶ arrow) buttons to select **On/Off**.

NOTE

HDMI® CEC List is automatically grayed out and set to Off when Enable HDMI® CEC is switched to Off. See "Using HDMI® CEC" on page 108.

- 8 To save the new entries, highlight **Done**, and then press the **OK** button. To return to factory defaults, highlight **Reset**, and then press the **OK** button.

To open the Channel Browser:

- ❖ Press the **BACK CB/NEXT CB** buttons on the remote control.
- ❖ Press the (◀ arrow) button to surf backward through the previously tuned channels in the History list, the channels in the ANT/ CABLE channel list, the inputs in the Inputs list, the favorite channels/inputs in the Favorites list, or the HDMI® CEC devices in the HDMI® CEC List.
- ❖ Press the (▶ arrow) button to surf forward through the channel History, the ANT/CABLE channel list, the Inputs list, the favorite channels/inputs in the Favorites list, or the HDMI® CEC List.

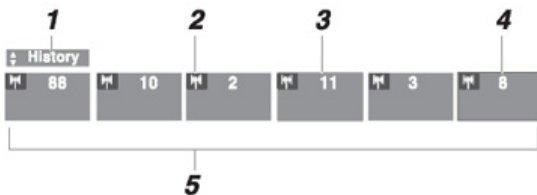
Elements of the Channel Browser

(Sample Illustration) Channel Browser elements

- 1 Current list (**History**, **ANT/CABLE**, **Inputs**, **Favorites**, or **HDMI® CEC**)
- 2 Input type
- 3 Channel or input currently being viewed

- 4 Channel or input that is currently highlighted in the browser
- 5 Channels stored in the History List

To toggle among the available lists:

After opening the Channel Browser, press the (▲/▼ arrow) buttons to toggle through the **History**, **ANT/CABLE**, **Inputs**, **Favorites**, or **HDMI® CEC** options.

NOTE

- ❖ The Channel Browser opens in History List by default. Once another list has been selected, the Channel Browser will open in the last selected list.
 - ❖ If all lists are turned off, pressing the **BACK CB/NEXT CB** buttons or the **FAV** button will not display the Channel Browser. If Favorites List is turned off, the **FAV** button will have no effect.
 - ❖ Pressing the **FAV** button will display the Channel Browser Favorites list regardless of the last selected list in the Channel Browser.
-

To tune to a channel or input in Browse mode:

- 1 While watching TV, press the **BACK CB/NEXT CB** buttons to display the Channel Browser and surf back to a previous item or surf forward to the next item in the list. In Browse mode, when you stop on an item in the Channel Browser, it is highlighted and the TV automatically tunes to the channel or input.
- 2 Press the **EXIT** button to close the Channel Browser.

To tune to a channel or input in Select mode:

- 1 While watching TV, press the **BACK CB/NEXT CB** buttons to display the Channel Browser and surf back to a previous item or surf forward to the next item in the list. In Select mode, when you stop on an item in the Channel Browser, it is highlighted, but you must press the **OK** button to tune the TV to the highlighted item.
- 2 Press the **OK** button to tune the TV to the highlighted item.
- 3 Press the **EXIT** button to close the Channel Browser.

Adding and clearing channels and inputs in the History List

Adding channels and inputs to the History List:

As a channel or input is tuned, the Channel Browser adds it to the History List and displays it on the right side of the Channel Browser. Previously tuned channels/inputs are shifted to the left, eventually moving off the left side. Press the **BACK CB** button to surf backward through the previously tuned channels/inputs. Any channel or input that is tuned repeatedly will not be repeated in the History List, but instead is moved to the end of the list on the right side of the Channel Browser.

The Channel Browser will store the following channels:

- ❖ All channels that are tuned using the numeric buttons on the remote control.
- ❖ All channels that are tuned using the **CH Up/Down** buttons on the remote control.

NOTE

Whenever an item is selected that cannot be tuned (for various reasons), the TV will automatically tune to the previously viewed channel or input.

Clearing channels from the History List:

- ❖ Reconfiguring the ANT/CABLE input will clear the History List.
- ❖ Turning off the TV will clear the History List.

Tuning channels

To tune to the next programmed channel, use the **CH Up/Down** buttons on the remote control or TV control panel.

Tuning to a specific channel (programmed or unprogrammed)

Tuning analog channels:

Press the Channel Number (0–9) buttons on the remote control. For example, to select channel 125, press 1, 2, 5, and then press the **OK** button.

Tuning digital channels:

Press the Channel Number (0–9) buttons on the remote control, followed by the **Dash/100** button, and then the sub-channel number. For example, to select digital channel 125-1, press 1, 2, 5, -, 1, and then press the **OK** button.

Tuning to the next programmed channel

Tuning analog channels:

Press the Channel Number (0–9) buttons on the remote control. For example, to select channel 125, press 1, 2, 5, and then press the **OK** button.

Tuning digital channels:

Press the Channel Number (0–9) buttons on the remote control, followed by the **Dash/100** button, and then the sub-channel number. For example, to select digital channel 125-1, press 1, 2, 5, –, 1, and then press the **OK** button.

NOTE If a digital channel is not programmed, either through the automatic channel scan or the Channel add function, see [“Auto Tuning” on page 52](#), you will have to tune the RF channel using the Channel Numbers and the Dash/100 button on the remote control.

Switching between two channels using Channel Return

The Channel Return feature allows you to switch between two channels without entering an actual channel number each time.

- 1 Select the first channel you want to view.
 - 2 Select a second channel using the Channel Number buttons (and the **Dash/100** button if selecting a digital channel).
 - 3 Press the **CH RTN** button on the remote control. The previous channel will display. Each time you press the **CH RTN** button, the TV will switch back and forth between the last two channels that were tuned.
-

NOTE If you press the CH RTN button from a non-antenna input, the TV will return to the last-viewed input.

Switching between two channels using SurfLock™

The SurfLock™ feature temporarily “memorizes” one channel to the **CH RTN** button, so you can return to that channel quickly from any other channel by pressing the **CH RTN** button.

To memorize a channel to the **CH RTN** button:

- 1 Tune the TV to the channel you wish to program into the **CH RTN** button.

- 2 Press and hold the **CH RTN** button for a few seconds until the message “Memorized” appears on the screen. The channel has been programmed to the **CH RTN** button.
- 3 You can then change channels repeatedly, and when you press the **CH RTN** button, the memorized channel will be tuned.

The TV will return to the memorized channel one time only. Once you press the **CH RTN** button and then change channels again, the CH RTN memory will be cleared and the button will function as Channel Return, by switching back and forth between the last two channels that are tuned. This feature also works for external inputs.

Selecting the picture size

You can view many program formats in several picture sizes—Native, 4:3, Full, TheaterWide 1, TheaterWide 2, TheaterWide 3, Normal, and Dot by Dot.

NOTE The picture size illustrations are examples only. The format of the image (in any of the picture sizes) depends on the format of the signal you are currently watching. Select the picture size that displays the current program in the way that looks best to you.

You can save separate picture size preferences for each input on your TV.

To select the picture size:

- 1 Press the **MENU** button on the remote.
- 2 With the Picture Size menu is displayed, do one of the following:
 - ❖ Repeatedly press the **PIC SIZE** button.
 - ❖ Press the corresponding number button (0-5) while the Picture Size menu is displayed.
 - ❖ Press the (**▲/▼** arrow) buttons while the Picture Size menu is displayed.

NOTE Using these functions to change the picture size (i.e., changing the height/width ratio) for any purpose other than your private viewing may be prohibited under the Copyright Laws of the United States and other countries, and may subject you to civil and criminal liability.

To select the picture size using the menus:

- 1 Select Picture Size in the Theater Settings menu.
- 2 Press the (◀/▶ arrow) buttons to select the desired picture size setting.
- 3 Highlight **Done**, and then press the **OK** button.

NOTE Some of the picture sizes may not be available depending on the receiving signal format (those will be "grayed out" in the Picture Size screen).

NOTE If you select a TheaterWide® picture size, the top and bottom edges of the picture (including subtitles or captions) may be hidden. To view these edges, adjust the Picture Position or try viewing the program in 4:3 or Full, see "[Scrolling the TheaterWide® picture \(TheaterWide 2 and 3 only\)](#)" on page 73.

Full

This setting is for viewing in the 16:9 (480i, 480p) source programs only.

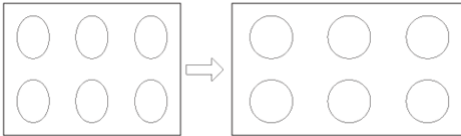

(Sample Illustration) Picture size - Full 16:9

If receiving a squeezed 4:3 format program, the picture is stretched horizontally to fill the width of the screen but not stretched vertically.

This setting is for viewing in the 1080i, 1080p, and 720p program source.

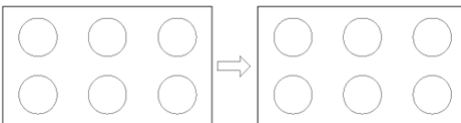

(Sample Illustration) Picture size - Full

The edges of the picture may be hidden.

TheaterWide 1

This setting is for viewing in 4:3 format programs.

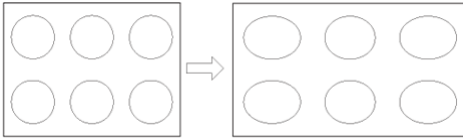

(Sample Illustration) Picture size - TheaterWide 1

The center of the picture remains close to its original proportion, but the left and right edges are stretched horizontally to fill the screen.

TheaterWide 2

This setting is for viewing letter box programs.

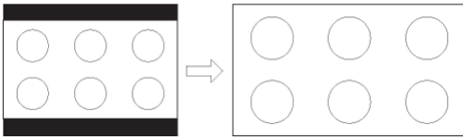

(Sample Illustration) Picture size - TheaterWide 2, letter box

The picture's top and bottom edges may be hidden*.

TheaterWide 3

This setting is for viewing letter box programs with subtitles.

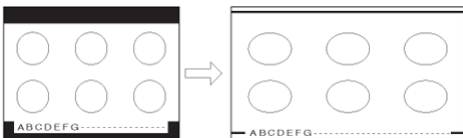

(Sample Illustration) Picture size - TheaterWide 3, letter box with subtitles

The picture's top and bottom edges are hidden*.

Native

These settings are for viewing in 480i (HDMI®), 480p (HDMI®), 720p, 1080i, and 1080p signal programs).

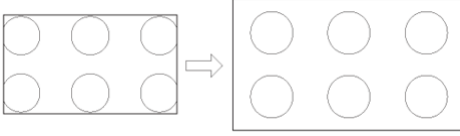

(Sample Illustration) Picture size - Native

- ❖ If receiving a 1080i, 1080p, 720p, 480i (HDMI®), or 480p (HDMI®) signal program, the video is scaled to display the entire picture within the borders of the screen (i.e. no over-scanning).
- ❖ This is especially useful for external HD sources such as DVHS movies, Video Games, or computer graphics.
- ❖ None of the picture is hidden.

NOTE

- ❖ This mode is supported only for HDMI® (1080i, 1080p, 720p, 480i, and 480p), ColorStream® (1080i and 720p), and ANT/CABLE (digital) inputs (1080i, 1080p, and 720p).
- ❖ Depending on the input signal, the picture's border may be hidden, displayed in black, or noisy.

4:3

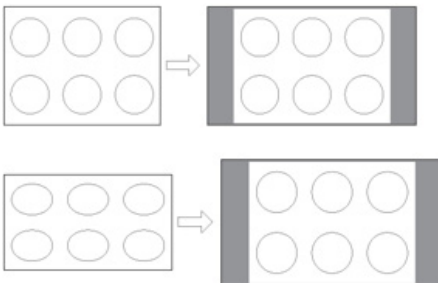

(Sample Illustration) Picture size - 4:3

Some program formats will display with sidebars and/or bars at the top and bottom.

*Scrolling the TheaterWide® picture (TheaterWide 2 and 3 only)***Normal**

This setting is for viewing VGA, SVGA, XGA, WXGA, and SXGA sources.

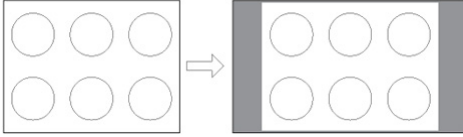

(Sample Illustration) Picture size - Normal

This size is a non-stretched display. Some input signal formats will display with sidebars and/or bars at the top and bottom.

Dot by Dot

This setting is for viewing VGA, SVGA, XGA, WXGA, and SXGA sources.

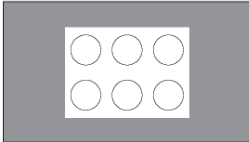

(Sample Illustration) Picture size - Dot by Dot

“Dot by Dot” is a non-scaling display. Depending on the input signal format, the picture appears with sidebars and/or bars at the top and bottom, for example, VGA input source).

* To view the hidden areas (such as subtitles or captions), see [“Scrolling the TheaterWide® picture \(TheaterWide 2 and 3 only\)”](#) on page 73.

Scrolling the TheaterWide® picture (TheaterWide 2 and 3 only)

You can set separate scroll settings for the TheaterWide 2 and TheaterWide 3 modes for each input.

To set the scroll settings:

- 1 Press the **MENU** button and open the **Picture** menu.

- Highlight **Theater Settings**, and then press the **OK** button.

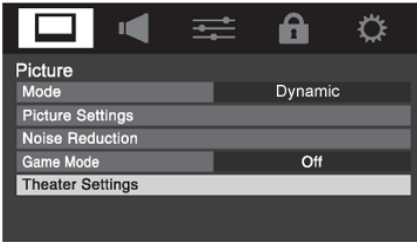

(Sample Image) Theater settings screen

- In the Picture Size field, select either **TheaterWide 2** or **TheaterWide 3**

NOTE You cannot scroll in any other mode.

- Press the (▼ arrow) button to select the **Picture Scroll** field.
- Press the (◀/▶ arrow) buttons to scroll the picture up and down as needed.
- To save the new settings, highlight **Done**, and then press the **OK** button. To revert to the factory defaults, highlight **Reset** and then press the **OK** button.

The adjustment range is from **-5** to **+10**.

Using the Auto Aspect feature

When this feature is set to On, the TV will automatically select the picture size when one of the following input sources is received:

- ❖ A 480i, 480p, 720p, 1080i digital signal from the ANT/CABLE input
- ❖ A 480i signal from the ColorStream® HD or Video input
- ❖ 480i, 480p, 720p, 1080i, 1080p, or VGA (60Hz) signal from the HDMI® 1/2 input

Aspect Ratio of Signal Source	Automatic Aspect Size (automatically selected when Auto Aspect is On)
4:3 Normal	4:3
4:3 Letter Box	TheaterWide 2
16:9 Full	Full

<i>Aspect Ratio of Signal Source</i>	<i>Automatic Aspect Size (automatically selected when Auto Aspect is On)</i>
--------------------------------------	--

Not defined (no ID-1 data or HDMI® aspect data)	The current picture size you set under, see “Selecting the picture size” on page 69.
---	--

NOTE The auto aspect ratio feature is not applicable to the PC input.

To turn on the auto aspect ratio feature:

- 1 Press the **MENU** button and open the **Picture** menu.
- 2 Highlight **Theater Settings**, and then press the **OK** button.
- 3 To save the new settings, highlight **Done**, and then press the **OK** button. To revert to the factory defaults, highlight **Reset** and then press the **OK** button.

To turn off the Auto Aspect ratio feature, Select **Off** in step 3 above.

Selecting the cinema mode

When you view a DVD (3:2 pulldown processed) from a DVD player connected to the **VIDEO**, **ColorStream® HD** (component video), or **HDMI®** inputs on the TV, smoother motion can be obtained by setting the **Cinema Mode** to **Film**.

To set the Cinema Mode to Film:
(available for 480i and 1080i signals)

- 1 Press the **MENU** button and open the **Picture** menu.
- 2 Highlight **Picture Settings**, and then press the **OK** button.
- 3 Highlight **Advanced Picture Settings**, and then press the **OK** button.
- 4 In the **Cinema Mode** field, select **Film**.
- 5 To set Cinema Mode to Video, Select **Video** in Step 4 above.

Using the FREEZE feature

To use the FREEZE feature:

- 1 When watching the TV, press the **FREEZE** button to freeze the picture.
- 2 To unfreeze the picture, press the **FREEZE** button again (or any other button).

NOTE Using the FREEZE function for any purpose other than your private viewing may be prohibited under the Copyright Laws of the United States and other countries, and may subject you to civil and criminal liability.

NOTE If the TV is left in FREEZE mode for more than 15 minutes, the FREEZE mode will automatically release and the TV returns to normal video.

Adjusting the picture

Selecting the picture mode

You can select your desired picture settings from the modes described below.

<i>Mode:</i>	<i>Description:</i>
Dynamic	Bright and dynamic picture (factory setting)
Standard	Standard picture settings (factory setting)
Movie	Lower contrast for darkened room (factory setting)
PC	Designed for viewing of PC tables and documents
Preference	Your personal preferences

NOTE PC mode is available for HDMI® and PC inputs only (other input sources are grayed out).

To select the picture mode using the menu system:

- 1 Press the **MENU** button and open the **Picture** menu.

- 2 Highlight **Mode**, and then press the **OK** button.

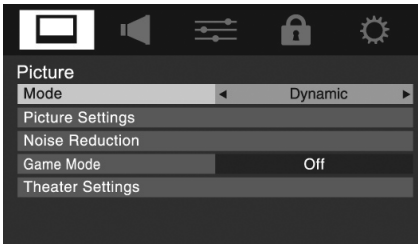

(Sample Image) Mode screen

- 3 Press the (▲/▼ arrow) buttons, and then press the **OK** button.

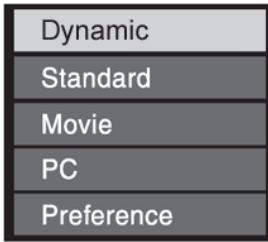

(Sample Image) Mode selections screen

Adjusting the picture quality

You can adjust the picture quality (Contrast, Backlight, DynaLight™, Brightness, Color, Tint, and Sharpness.) to your personal preferences.

<i>Selection</i>	<i>Pressing (◀)</i>	<i>Pressing (▶)</i>
Contrast	lower	higher
Backlight*	darker	lighter
DynaLight®**	On/Off	On/Off
Brightness	darker	lighter
Color	paler	deeper
Tint	reddish	greenish
Sharpness	softer	sharper

* **Backlight:** Adjusts the brightness of the entire screen. When in video mode and no signal is input, this selection is automatically set to 0. (Settings are stored in memory.)

**DynaLight®: This function automatically strengthens the black coloring of dark areas in the video according to the level of darkness.

To adjust the picture quality:

- 1 Press the **MENU** button and open the **Picture** menu.
- 2 Highlight **Picture Settings**, and then press the **OK** button.
- 3 Press the (▲/▼ arrow) buttons to select the picture quality you wish to adjust (Contrast, Backlight, DynaLight, Brightness, Color, Tint, or Sharpness), and then press the (◀/▶ arrow) buttons to adjust the setting.
- 4 To save the new settings, highlight **Done**, and then press the **OK** button. You can use any of the picture modes, see [“Selecting the picture mode” on page 76](#), as a starting point for adjusting the picture settings. To revert back to the base mode that you began adjusting the picture settings from, highlight **Reset**, and then press the **OK** button.

The picture qualities you adjusted are automatically saved in the Preference mode, see [“Selecting the picture mode” on page 76](#) until **Reset** is selected.

Using closed captions

Closed caption mode has two options:

- ❖ **Captions**—An on-screen display of the dialogue, narration and sound effects of TV programs and videos that are closed captioned (usually marked “CC” in program guides).
- ❖ **Text**—An on-screen display of information not related to the current program, such as weather or stock data (when provided by individual stations).

To view captions or text:

- 1 Press the **MENU** button to open the **Preferences** menu, and then highlight **Base CC Mode**.
- 2 Press the (◀/▶ arrow) buttons to select the desired closed caption mode, and then press the **OK** button.

To view captions, highlight **CC1**, **CC2**, **CC3**, or **CC4**.
(CC1 displays translation of the primary language in your area.)



(Sample Illustration) Viewing captions

NOTE If the program or video you selected is not closed captioned, no captions will display on-screen.

To view text, highlight **T1**, **T2**, **T3**, or **T4**.

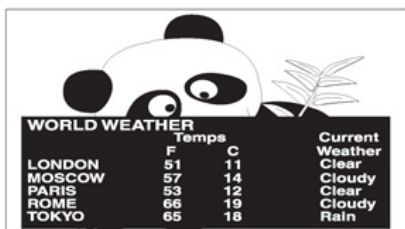

(Sample Illustration) Captions - text

NOTE If text is not available in your area, a black rectangle may appear on screen. If this happens, set the Base CC Mode to Off.

To turn off closed caption mode, select **Off** in step 2 above.

NOTE A closed caption signal may not display in the following situations:

- ❖ When a recording has been dubbed
- ❖ When the signal reception is weak
- ❖ When the signal reception is non-standard

Digital CC settings

You can customize the closed caption display characteristics by changing the background color, opacity, text size, type, edge, and color.

- NOTE**
- ❖ These settings are available for digital channels only.
 - ❖ You cannot set Caption Text and Background as the same color.

To customize closed captions:

- 1 Press the **MENU** button to open the **Preferences** menu.
- 2 Highlight **Digital CC Settings**, and then press the **OK** button.
- 3 Press the (▲/▼ arrow) buttons to highlight the characteristic you wish to change, and then press the (◀/▶ arrow) buttons to select the format for that characteristic.
- 4 To save the new settings, highlight **Done**, and then press the **OK** button.
- 5 To revert to the factory defaults, highlight **Reset**, and then press the **OK** button.

<i>Mode:</i>	<i>Description</i>
Caption size	Auto, Small, Standard, Large
Caption text type	Auto, Default, Mono (with Serif), Prop. (with Serif), Mono (without Serif), Prop. (without Serif), Casual, Cursive, Small Capitals
Caption text edge	Auto, None, Raised, Depressed, Uniform, Left Drop Shadow, Right Drop shadow
Caption text color	Auto, Black, White, Red, Green, Blue, Yellow, Magenta, Cyan
Text foreground opacity	Auto, Transparent, Translucent, Flashing, Solid
Background color	Auto, Black, White, Red, Green, Blue, Yellow, Magenta, Cyan
Text background opacity	Auto, Transparent, Translucent, Flashing, Solid
Caption text edge color	Auto, Black, White, Red, Green, Blue, Yellow, Magenta, Cyan

CC Selector

You can use the CC Selector to temporarily override the default analog caption mode (set in Base CC Mode) for a particular channel. However, once you change to another channel, the closed

caption setting will automatically change back to the current Base CC Mode setting.

You can also use the CC Selector to select digital closed caption services, if available. When such services are not available, the CC Selector presents a default list of services. If the selected service is not available, the next best service will be used.

To select closed captions:

- 1 Press the **MENU** button to open the **Preferences** menu.
- 2 Highlight **CC Selector**, and then press the **OK** button.
- 3 Press the (**▲/▼** arrow) buttons to select the Closed Caption, and then press the (**◀/▶** arrow) buttons to select the desired service.
- 4 To save the new settings, highlight **Done**, and then press the **OK** button.
- 5 Press the **EXIT** button.

NOTE You can also press the **SUBTITLE** button to open CC Selector and follow the instructions.

Adjusting the audio

Muting the sound

Press the **MUTE** button to partially reduce (1/2 Mute) or turn off (Mute) the sound. Each time you press the **MUTE** button, the mute mode changes in the following order: 1/2 Mute, Mute, Volume, 1/2 Mute, etc.



(Sample Image) Levels of mute

If closed caption mode is set to **Off** when selecting **MUTE** mode, the closed caption feature becomes active if the TV program is closed captioned. To mute the audio without activating the closed captioning, press the **VOL (-)** button to set the volume to 0.

For more information, see [“Using closed captions” on page 78](#).

NOTE If you modify items in the **SOUND** menu while Mute is active, Mute is cancelled.

Using the digital audio selector

You can use the Digital Audio Selector to conveniently switch between audio tracks on a digital channel (for those channels that have multiple audio tracks). This temporarily overrides the audio track chosen by the language option under Audio Setup, see “Selecting stereo/SAP broadcasts” on page 82.

- 1 Press the **MENU** button to open the **Sound** menu.
- 2 Highlight **Digital Audio Selector**, and then press the **OK** button.

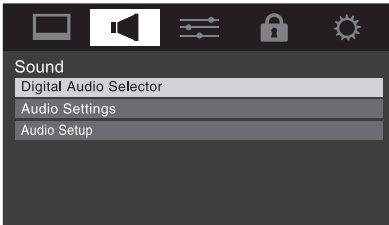

(Sample Image) Digital Audio Selector screen

- 3 Press the (◀/▶ arrow) buttons to select the desired service.
- 4 Press the **EXIT** button.

Selecting stereo/SAP broadcasts

The multi-channel TV sound (MTS) feature allows you to output high-fidelity stereo sound. MTS also can transmit a second audio program (SAP) containing a second language, music or other audio information (when provided by individual stations).

When the TV receives a stereo or SAP broadcast, the stereo mark or word “SAP” appears when the **DISPLAY** button is pressed. The MTS feature is only available for analog signals on the ANT/CABLE input.

To listen in stereo sound:

- 1 Press the **MENU** button to open the **Sound** menu.
- 2 Highlight **Audio Setup**, and then press the **OK** button.
- 3 In the **MTS** field, select **Stereo**.
- 4 To save the new settings, highlight **Done**, and then press the **OK** button.
- 5 To reset the settings to the factory defaults, highlight **Reset**, and then press the **OK** button.

-
- NOTE**
- ❖ You can typically leave the TV in Stereo mode because it outputs the type of sound being broadcast (stereo or monaural).
 - ❖ If the sound is noisy, select Mono to reduce the noise.
-

To listen to an alternate language on an ATSC digital station (if available), highlight the **Language** field in step 3 above, and then press the (◀/▶ arrow) buttons to select the language you prefer.

To listen to a second audio program on an analog station, if available, select **SAP** in step 3 above.

- 1 Press the **MENU** button. Select **Settings, SOUND, MTS**.
 - 2 Press the (◀/▶ arrow) buttons to select **SAP**. Press the **EXIT** button.
-

- NOTE**
- ❖ A second audio program (SAP) can be heard only on those TV stations that offer it. For example, a station might broadcast another language as a second audio program. If you have SAP on, you will see the current program on the screen but hear the other language instead of the program's normal audio.
 - ❖ If you have SAP on and the station you are watching is not broadcasting a second audio program, the station's normal audio will be output. However, occasionally there is no sound at all in SAP mode. If this happens, set the MTS feature to Stereo mode.
-

Using the MTS button

If you press the **AUDIO** button when an analog channel is tuned, the Analog Audio bar appears and displays Stereo, SAP, Mono as the options.

If you press the **AUDIO** button when a digital channel is tuned, the Digital Audio bar will appear and offer different audio choices for the digital channel.

If you press the **AUDIO** button when an external input is selected, no Audio bar appears.

Adjusting the audio quality

You can adjust the audio quality by adjusting the bass, treble and balance.

To adjust the audio quality:

- 1 Press the **MENU** button to open the **Sound** menu.
- 2 Highlight **Audio Setup**, and then press the **OK** button.
- 3 Press the (▲/▼ arrow) buttons to highlight the item you wish to adjust (Bass, Treble, or Balance).
- 4 Press the (◀/▶ arrow) buttons to adjust the level.
 - ❖ ◀ makes the bass or treble weaker or increases the balance in the left channel (depending on the item selected).
 - ❖ ▶ makes the bass or treble stronger or increases the balance in the right channel (depending on the item selected).
- 5 To save the new settings, highlight **Done**, and then press the **OK** button.
- 6 To reset the settings to the factory defaults, highlight **Reset**, and then press the **OK** button.

Audyssey Premium Television™

These televisions use a suite of technologies for better sound including:

- ❖ Audyssey EQ® - provides clear, accurate and natural sound right out of the box. This technology ensures you enjoy your audio experience as much as your video.
- ❖ Audyssey ABX™- technology uses sophisticated driver analysis and low frequency monitoring to extend the range and bass of small speakers. This enables the system to produce lower frequencies than otherwise would be possible.
- ❖ Audyssey® Dynamic Volume- automatically adjusts volume to provide a consistent sound level between television programs, commercials, and between the loud and soft passages of movies.

Audyssey ABX™

Audyssey ABX™ technology uses sophisticated driver analysis and low frequency monitoring to extend the range and bass of small speakers.

To turn on Audyssey ABX™:

- 1 Press the **MENU** button and open the **Sound** menu.
- 2 Highlight **Audio Settings**, and then press the **OK** button.

- 3 Press the (▲/▼ arrow) buttons to highlight the **Audyssey ABX™** field.
- 4 Press the (◀/▶ arrow) buttons to select **On**.

Using Audyssey Dynamic Volume®

This feature provides a consistent sound volume between television programs, commercials, and between the loud and soft passages of movies.

- 1 Press the **MENU** button. Select Settings, SOUND, Audyssey Premium Television, Dynamic Volume.
- 2 Press the (◀/▶ arrow) buttons to select **ON** or **Off**.

- NOTE**
- ❖ If Dynamic Range Control is set to On, this feature is automatically set to Off.
 - ❖ This feature does not affect the audio signal output from the DIGITAL AUDIO OUT terminal.

Selecting the optical audio output format

You can select the optical audio output format when you connect a Dolby® Digital decoder or other digital audio systems to the TV's Digital Audio Out terminal.

To select the optical audio output format:

- 1 Press the **MENU** button to open the **Sound** menu.
- 2 Highlight **Audio Setup**, and then press the **OK** button.
- 3 In the **Digital Output Format** field, select either **Dolby Digital** or **PCM**, depending on your device.
- 4 To save the new settings, highlight **Done**, and then press the **OK** button.
- 5 To reset the settings to the factory defaults, highlight **Reset**, and then press the **OK** button.

Using the Dolby® Digital Dynamic Range Control feature

You can further compress Dolby® Digital dynamic range, allowing you to switch from digital to analog broadcasts at the same dynamic range.

To use the Dolby® Digital Dynamic Range Control:

- 1 Press the **MENU** button to open the **Sound** menu.

- 2 Highlight **Audio Setup**, and then press the **OK** button.
- 3 In the **Dolby® Digital Dynamic Range Control** field, select either **Compressed**. When **Standard** is selected, the audio outputs with minimal compression.
- 4 To save the new settings, highlight **Done**, and then press the **OK** button.
- 5 To reset the settings to the factory defaults, highlight **Reset**, and then press the **OK** button.

- NOTE**
- ❖ This feature is available when tuned to a digital RF channel with the Dolby® Digital signal.
 - ❖ The Dolby® Digital Dynamic Range Control will function in relation to Digital Output Format (PCM mode).

Using the Locks menu

The Locks menu includes the Enable Rating Blocking, Edit Rating Limits, Input Lock, Panel Lock, GameTimer and New PIN Code features. You can use these features after entering the correct PIN code.

Entering the PIN code

- 1 Press the **MENU** button to open the **Locks** menu.



(Sample Image) Lock menu screen (for USA region)

- 2 Press the (▼ arrow) button to display the PIN code entry screen.

The Lock System screen appears if a PIN code has not been stored.

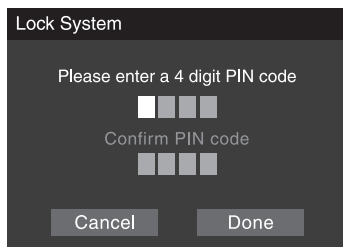

(Sample Image) Lock menu - store PIN screen

- 3 Press the Channel Number buttons to enter a new four-digit code, enter the code a second time to confirm, and then press the **OK** button.

The Locks/Active screen appears if the PIN code is already stored.

- 4 Use the Number buttons to enter your four-digit code, and then press the **OK** button.

NOTE If the wrong PIN code is entered, the message "Incorrect PIN code, please try again!" appears.

- 5 Highlight **Retry**, and then press the **OK** button.
- 6 Enter the code again, and then press the **OK** button.

When the correct PIN code is entered, the Locks menu opens.

Forgotten PIN code

While the PIN code entering screen is displayed, press the **INFO** button four times within five seconds. The PIN code will be cleared and you can enter a new PIN code.

Changing your PIN code

- 1 Press the **MENU** button to open the **Locks** menu.
- 2 Press the (▼ arrow) button to display the PIN code entering screen.
- 3 Enter your four-digit PIN code, and then press the **OK** button.

- 4 Press the (▼ arrow) button to highlight **New PIN Code**, and then press the **OK** button.
- 5 Press the Number buttons to enter a new four-digit code. Reenter the PIN code to confirm it.
- 6 Press the **OK** button.
The new PIN code is now active.

NOTE The PIN code cannot be set to "0000."

Using parental controls (for USA region)

Blocking TV programs and movies by rating (V-Chip)

Some TV programs and movies include signals that classify the content of the program (as unsuitable for younger viewers). The V-Chip feature in this TV detects the signals and blocks the programs according to the ratings you select.

- 1 Press the **MENU** button to open the **Locks** menu.
- 2 Press the (▼ arrow) button to display the PIN code entering screen.
- 3 Enter your four-digit PIN code, and then press the **OK** button.
- 4 Press the (▼ arrow) button to highlight **Enable Rating Blocking**, and then press the **OK** button.
- 5 Press the (▶ arrow) button to select **On**.



(Sample Image) Locks menu - Enable Rating Blocking selection (for USA region)

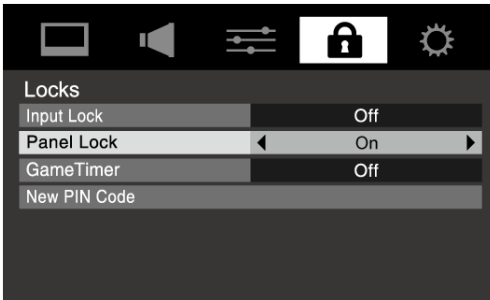

(Sample Image) Locks menu screen for other regions

- 6 Press the (▼ arrow) button to highlight **Edit Rating Limits**, and then press the **OK** button.
- 7 Press the (▲/▼/◀/▶ arrow) buttons, and then press the **OK** button.

A box with an “X” is a rating that will be blocked. As you highlight a rating, a definition for the rating appears at the bottom of the screen.

- 8 To save the new settings, highlight **Done**, and then press the **OK** button.

NOTE

Above selection of blocking level is for U.S V-Chip system. For Canada rating, you can highlight “Canada RS,” and then press the OK button. Another “Canadian Rating Menu” screen appears.

Downloading an additional rating system

In the future, an additional rating system may become available for use in selectively blocking TV programs and movies.

NOTE

The currently tuned station must be receiving a digital signal before an additional rating system can be downloaded.

To download the additional rating system, if available:

- 1 Press the **MENU** button to open the **Locks** menu.
- 2 Press the (▼ arrow) button to display the PIN code entering screen.
- 3 Enter your four-digit PIN code, and then press the **OK** button.
- 4 Press the (▼ arrow) button to highlight **Enable Rating Blocking**, and then press the **OK** button.

- 5 Press the (▶ arrow) button to select **On**.
- 6 Press the (▼ arrow) button to highlight **Edit Rating Limits**, and then press the **OK** button.

The Edit Rating Limits screen appears.

- 7 Highlight **Alt RS**, and then press the **OK** button.

The Edit Alternate Ratings screen appears.

NOTE

- ❖ The Alt RS button will only be available if an additional rating system is currently available.
 - ❖ It may take several minutes for the TV to download the additional rating system.
 - ❖ The information displayed in the Alternate Ratings screen will depend on the configuration of the additional rating system available at the time of download.
-

- 8 Press the (▲/▼/◀/▶ arrow) buttons, and then press the **OK** button.

A box with an “X” is a rating that will be blocked.

- 9 To save the new settings, highlight **Done**, and then press the **OK** button.

- 10 In the Edit Rating Limits screen, highlight **Done**, and then press the **OK** button.
-

NOTE

- ❖ The additional rating system can only be downloaded one time. You will not be able to download any updates to the rating system should such updates become available.
 - ❖ The additional rating system is not designed, transmitted or controlled by the TV or Toshiba, nor is the availability of an additional rating system determined or controlled by Toshiba. Similarly, the rating of programs in an additional rating system is not determined, transmitted or controlled by the TV or Toshiba.
 - ❖ The additional rating system is an evolving technology; therefore, availability, content and format may vary.
-

Rating system

Independent rating system for broadcasters:

<i>Ratings:</i>	<i>Description and Content themes:</i>
TV-MA	Mature Audience Only (This program is specifically designed to be viewed by adults and therefore may be unsuitable for children under 17. L) Crude or indecent language S) Explicit sexual activity V) Graphic violence
TV-14	Parents Strongly Cautioned (This program contains some material that many parents would find unsuitable for children under 14 years of age.) D) Intensely suggestive dialogue L) Strong, coarse language S) Intense sexual situations V) Intense violence
TV-PG	Parental Guidance Suggested (This program contains material parents may find unsuitable for younger children.) D) Some suggestive dialogue L) Infrequent coarse language S) Some sexual situations V) Moderate violence
TV-G	General Audience (Most parents would find this program suitable for all ages)
TV-Y7, TV-Y7FV	Directed to Older Children (This program is designed for children age 7 and above. NOTE: Programs in which fantasy violence may be more intense or more combative than other programs in this category are designated TV-Y7FV.)
TV-Y	All Children (This program is designed to be appropriate for all children)

Independent rating system for movies:

<i>Ratings:</i>	<i>Description and Content themes:</i>
X	X-rated (For adults only)
NC-17	Not intended for anyone 17 and under
R	Restricted (Under 17 requires accompanying parent or adult)
PG-13	Parents Strongly Cautioned (Some material may be inappropriate for children under 13)
PG	Parents Strongly Cautioned (Some material may be inappropriate for children under 13)
G	General Audience (Appropriate for all ages)

Indication other than rating system:

<i>Display:</i>	<i>Description:</i>
NONE	The program is rated None.
(No rating appears)	No rating information is provided.

NOTE

If you place an "X" in the box next to "None" Rated, programs rated "None" or "Not Rated" will be blocked; Programs that do not provide any rating information will not be blocked.

Displaying ratings

To display the rating of the program you are watching, press the **INFO** button on the remote control. If it is rated "None" the word "NONE" appears in the INFO screen. If rating information is not provided, no rating will appear in the INFO screen.



(Sample Image) Enable Rating Blocking screen

Blocking TV programs by Canada rating

- 1 Press the **MENU** button to open the **Locks** menu.
- 2 Press the (▼ arrow) button to display the PIN code entering screen.
- 3 Enter your four-digit PIN code, and then press the **OK** button.
- 4 Press the (▼ arrow) button to highlight **Enable Rating Blocking**.
- 5 Press the (▶ arrow) button to select **On**.
- 6 Press the (▼ arrow) button to highlight **Edit Rating Limits**, and then press the **OK** button.
The Edit Rating Limits screen appears.
- 7 Highlight **Canada RS**, and then press the **OK** button.
The Canadian Rating Menu screen appears.

Using parental controls (for USA region)

- 8 Press the (▲/▼/◀/▶ arrow) buttons, and then press the **OK** button to select the level of blocking you prefer.
A box with an “X” is a rating that will be blocked.
- 9 To save the new settings, highlight **Done**, and then press the **OK** button.
- 10 In the Edit Rating Limits screen, highlight **Done**, and then press the **OK** button.

Rating system for programs in English:

<i>Ratings:</i>	<i>Description and Content themes:</i>
E	Exempt shows
C	Children ages of 2 to 7 years
C8+	Children ages of 8 years and older
G	General programming
PG	Parental Guidance
14+	Viewers 14 and older
18+	Adult programming

Rating system for programs in French:

<i>Ratings:</i>	<i>Description and Content themes:</i>
E	Exempt shows
G	General programming
8 ans+	Not recommended for ages under 8
13 ans+	Not recommended for ages under 13
16 ans+	Not recommended for ages under 16
18 ans+	Programming restricted to adults

Unlocking programs temporarily

If you try to tune to a program that exceeds the rating limits you have set, the TV will enter program lock mode and a warning message appears on the screen. Follow the instructions to temporarily unlock the program.

This program exceeds the rating limit you set.
Push 'MUTE' to enter PIN.

(Sample Illustration) Warning - exceeded rating limit

You can either temporarily unlock the program or select an unlocked program to watch.

To temporarily unlock the program:

- 1 Press the **MUTE** button.
- 2 Enter your four-digit PIN code, and then press the **OK** button.

If the correct code is entered, the program lock mode is released and the normal picture appears. All locking will be enabled again when you change the channel.

Using the input lock feature

You can use the Input Lock feature to lock the video inputs (Video, ColorStream® HD, HDMI 1, HDMI 2, and PC) and channels 3 and 4. You will not be able to view the input sources or channels until you unlock the inputs.

To lock/unlock the video inputs:

- 1 From the Locks menu, press the (▼ arrow) button to display the PIN code entering screen.
- 2 Enter your four-digit PIN code, and then press the **OK** button.
- 3 Press the (▼ arrow) button to highlight Input Lock, and then press the (▶ arrow) button to select the level of video input locking you prefer.

<i>Mode:</i>	<i>Description:</i>
Video	Locks Video, ColorStream® HD, HDMI 1, HDMI 2 and PC.
Video+	Locks Video, ColorStream® HD, HDMI 1, HDMI 2, PC and channels 3 and 4. Select Video+ if you play video tapes via an ANT/CABLE input.
Off	Unlocks all video inputs and channels 3 and 4.

- 4 Press the **EXIT** button.

Locking channels



With the Lock feature, you can lock specific channels. Locked channels can only be accessed by entering the PIN code, see “Entering the PIN code” on page 86.

To lock channels:

- 1 From the Setup menu, highlight **Installation**, and then press the **OK** button.
- 2 Press the **OK** button to select **Terrestrial**.

- Press the (▲/▼ arrow) buttons to select **Channel Options**, and then press the **OK** button.

The list of channels appear.

Channel Options			
Ch.	Type		
1	Digital	<input type="checkbox"/>	<input type="checkbox"/>
2	Analog	<input type="checkbox"/>	<input type="checkbox"/>
3	Digital	<input type="checkbox"/>	<input type="checkbox"/>
4	Analog	<input type="checkbox"/>	<input type="checkbox"/>
5	Analog	<input type="checkbox"/>	<input type="checkbox"/>
6	Analog	<input type="checkbox"/>	<input type="checkbox"/>
7	Analog	<input type="checkbox"/>	<input type="checkbox"/>
8	Analog	<input type="checkbox"/>	<input type="checkbox"/>

(Sample Illustration) Channel options

- Press the (▶ arrow) button, and then press the (▲/▼ arrow) buttons to select a channel in the lock column.
- Press the **OK** button.
PIN code entry will be required to set a locked channel.

NOTE If the PIN code has not yet been set, a warning message appears.

- A check appears in the box.
- To remove the check, press the **OK** button.
- Press the **EXIT** button.

Using the GameTimer®

You can use the GameTimer® to set a time limit for playing a video game (30–120 minutes). When the GameTimer® expires, the TV enters Input Lock mode and locks out the input source for the video game device.

To set the GameTimer®:

- From the Locks menu, press the (▼ arrow) button to display the PIN code entering screen.
- Enter your Four-digit PIN code, and then press the **OK** button.
- Press the (▼ arrow) button to highlight **GameTimer**, and press the (▶ arrow) button to select the length of time until the Input Lock is activated (30, 60, 90 or 120 minutes).
- Press the (◀/▶ arrow) buttons to select **30**, **60**, **90**, or **120** minutes.

To cancel the GameTimer[®], select **Off** in step 3 above.

To deactivate the Input Lock once the GameTimer[®] has activated it:

- ❖ Set the Input Lock to **Off**, see “Using the GameTimer[®]” on page 95.

- NOTE**
- ❖ A message appears when 10 minutes, 3 minutes, and 1 minute are remaining.
 - ❖ If the TV loses power with time remaining, the TV will enter Input Lock mode when power is restored (as if the GameTimer had been activated). You must deactivate the Input Lock, see “Using the GameTimer[®]” on page 95.

Using the panel lock feature

You can lock the control panel to prevent your settings from being changed accidentally (by children, for example). When Panel Lock is set to **On**, none of the controls on the control panel operate except **POWER**.

To lock the control panel:

- 1 Press the **MENU** button to highlight the **Locks** menu.
- 2 Press the (▼ arrow) button to display the
- 3 Enter your four-digit PIN code, and then press the **OK** button.
- 4 Press the (▼ arrow) button to highlight **Panel Lock**.
- 5 Press the (▶ arrow) button to select **On**.

When the control panel is locked and any button on the control panel (except **POWER**) is pressed, the message “NOT AVAILABLE” appears.

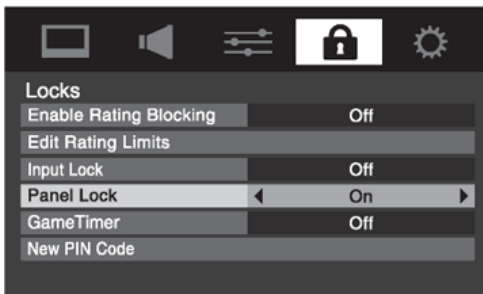

(Sample Illustration) Panel Lock screen

To unlock the control panel, select **Off** in Step 5 above or press and hold the **VOLUME (-)** button on the TV control panel for a few seconds until the volume icon appears.

Using the PC settings feature

You can view an image from a PC on the TV screen. When a PC is connected to the TV's PC IN terminal, you can use the PC Settings feature to make adjustments to the image. If the edges of the picture are cut off, readjust the Horizontal Position and Vertical Position. If the picture is affected by interference, readjust the Clock Phase and Sampling Clock.

To adjust the PC settings:

- 1 Repeatedly press the **INPUT** button to select **PC Input** mode, see “Adjusting the picture” on page 76.
- 2 Press the **MENU** button to open the **Setup** menu.
- 3 Press the (▲/▼ arrow) buttons to select **PC Settings**, and then press the **OK** button.

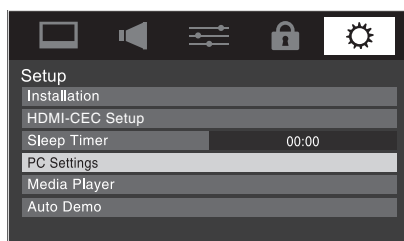

(Sample Image) PC Settings screen

NOTE If a computer is not connected or there is no PC input signal, this feature will be grayed out in the Setup menu.

- 4 Press the (▲/▼ arrow) buttons to select an item.
- 5 Press the (◀/▶ arrow) buttons to make the appropriate adjustments.

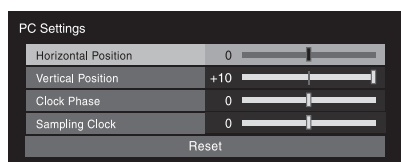

(Sample Image) PC Settings - adjustments screen

NOTE The screen is disrupted momentarily while adjusting the PC settings. This is not a sign of malfunction.

<i>Mode:</i>	<i>Description:</i>
Horizontal Position	Moves the picture left/right. The adjustment range is within ± 10 from center.*
Vertical Position	Moves the picture up/down. The adjustment range is within ± 10 from center.*
Clock Phase	Helps to reduce noise and sharpen the picture. The adjustment range is within ± 16 from center.*
Sampling Clocks	Helps to reduce noise and minimize periodic vertical stripes on the screen. The adjustment range is within ± 10 from center.*
Reset	Highlight this item, and then press the OK button to get an optimum adjustment automatically.

* The default settings and/or adjustment ranges may vary depending on the input signal format.

Setting the PC Audio

You can output or mute sound from your computer when connecting it to your TV, using the AUDIO IN terminal and PC audio cable.

To set the PC Audio:

- 1 Press the **MENU** button to open the **Sound** menu.
- 2 Highlight **Audio Setup**, and then press the **OK** button.
- 3 Press the ($\blacktriangle/\blacktriangledown$ arrow) buttons to select **PC Audio**, and then press the ($\blacktriangleleft/\blacktriangleright$ arrow) buttons to select **No** or **Yes**.
 - ❖ **Yes:** When viewing the PC input, the audio from the PC Audio input can be heard.
 - ❖ **No:** When viewing the PC input, there will be no audio.

NOTE Because the PC and HDMI 1 inputs share the same set of analog audio inputs, the PC Audio menu setting influences the HDMI 1 Audio menu setting. If PC Audio is set to "No" the HDMI 1 Audio setting changes to "Auto" If PC Audio is set to "Yes" the HDMI 1 Audio setting is set to "Digital" and is grayed out in the menu.

Using the Media Player

Using Media Player with a USB device

You can enjoy photos or music contents stored on a USB storage device.

Photo Viewer specifications:

- ❖ Data type: JPEG EXIF ver 2.1
- ❖ File format: JPEG
- ❖ Maximum photo size: 6 MB
- ❖ Maximum number of files: 500/folder
- ❖ Maximum photo resolution: 4096 x 4096 pixels
- ❖ Best photo resolution:
1920 x 1080 pixels

Music Player specifications:

- ❖ File format: MP3
- ❖ Sampling frequency: 16 kHz, 22.05 kHz, 24 kHz,
32 kHz, 44.1 kHz, 48 kHz
- ❖ Bit rate: from 8 to 320 kbps
- ❖ Maximum number of files: 500/folder

Supported file system: FAT16 and FAT32

-
- NOTE**
- ❖ Gently insert the USB device into the port and do not remove while viewing Media Player.
 - ❖ USB device: USB Mass Storage Class device (MSC)
 - ❖ Connectivity is not guaranteed for all devices.
 - ❖ Connect the USB device to the TV directly.
 - ❖ Do not use a USB Hub.
 - ❖ You must obtain any required permission from copyright owners to use copyright content. Toshiba cannot and does not grant such permission.
 - ❖ Depending on the file size and amount in your USB storage device, it may take some time for loading to view. A message will display on-screen when loading files from the USB storage device.
 - ❖ Only limited types of U3 USB device are supported. Therefore, it is suggested not to use U3 USB for playing Media Player.
 - ❖ Non-supported characters will be replaced with a square.
-

Auto Start function

When Auto Start is enabled, you will be asked if you want to start the Media Player when a USB device is inserted. If Auto Start is disabled, you must manually start the Media Player from the menu.

To change the Auto Start setting:

- 1 Press the **MENU** button to open the **Setup** menu.
- 2 Press the (▼ arrow) button, and then press the **OK** button.
- 3 Press the (▲/▼ arrow) buttons to highlight **Auto Start**.
- 4 Press the (◀/▶ arrow) buttons to select **On/Off**.

To open the Media Player

Auto Start:

- 1 Gently insert a supported USB storage device to the USB port on the rear side of the TV. A prompt will appear.

-
- NOTE** If you repeatedly insert and remove the USB connector, the prompt may not appear.
-

- 2 Press the (◀/▶ arrow) buttons to select **Yes**, and then press the **OK** button.

The Media Player menu will appear. When you select No, nothing happens.

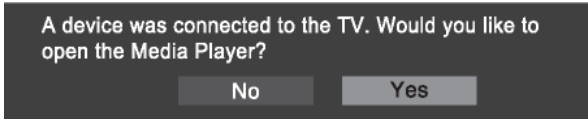

(Sample Image) Media Player - open screen

- NOTE**
- ❖ The prompt will disappear after about 10 sec.
 - ❖ If Auto Start is set to off, you can start the Media Player manually.

Manual Start:

- 1 Press the **MENU** button to open the **Setup** menu.
- 2 Press the (▼ arrow) button to select **Media Player**, and then press the **OK** button.
- 3 Press the (▲/▼ arrow) buttons to highlight **Photo** or **Music**, and then press the **OK** button.



(Sample Image) Media Play screen

- NOTE**
- ❖ The viewer will also open even if there are no photo or music files.
 - ❖ While the Media Player is active, the main menu cannot be displayed.

Viewing photo files

There are three types of view modes.

Multi View:

This view allows you to search for photos in a grid format. These pictures are displayed using thumbnail data in each image file.

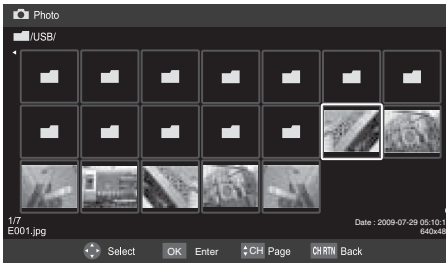

(Sample Image) Media Player - photos screen

- 1 Press the (▲/▼/◀/▶ arrow) buttons to move the highlight in one window. If all of the photos will not fit in one screen, when pressing the (◀ arrow) button at the top left thumbnail, the screen will move to the previous page. Conversely, when pressing the (▶ arrow) button at the bottom right thumbnail, the screen will move to the next page. **CH Up/Ch down** buttons can be used to page up/down the photo list when there are more photos than will fit onto one screen.
- 2 When you select a folder, press the **OK** button to move to the next layer, or press the **RETURN** button to return to the previous layer.
- 3 Press the **OK** button to view the selected photo in Single View mode.

Single view

In this view mode, only files located in the selected directory shall be displayed. This view allows you to change the photo content manually. When moving from Multi View to the Single View, the currently selected photo shall be displayed.

- 1 Press the (▶ arrow) button to view the next photo. Press the (◀ arrow) button to view the previous photo.
- 2 Press the (▲ arrow) button to rotate the image 90° counterclockwise. Press the (▼ arrow) button to rotate the image 90° clockwise.

Slide show

This view allows you to watch a slide show of the photos. In this mode, only files located in the selected directory will be played.

- 1 To start slide show, press the **OK** button to select **Single View** mode.
- 2 Press the (◀/▶ arrow) buttons to view the previous or next photo.

To set Interval Time and Repeat settings:

- 1 Press the **MENU** button to open the **Quick Menu**.
- 2 Press the (▲/▼ arrow) buttons to select either **Interval Time** or **Repeat**.
- 3 Press the (◀/▶ arrow) buttons to adjust the setting, and then press the **RETURN** button.

NOTE Zoom and Picture size functions are disable.

To close the Photo Viewer, press the **EXIT** button. The television will return to the last viewed channel or external input.

Playing music files

You can listen to music from a list of available files.

- 1 Press the **MENU** button to open the **Setup** menu.
- 2 Highlight **Media Player**, and then press the **OK** button.
- 3 Press the (▼ arrow) button to select **Music**.
- 4 Press the (▲/▼ arrow) buttons to select a file or folder. The **CH Up/CH Down** buttons can be used to page up/down the music list when there are more files than will fit onto one screen.
- 5 When you select a folder, press the **OK** button to move to the next layer. Press the **RETURN** button to move back to the previous layer.
- 6 With the desired file selected, press the **OK** or **PLAY** button to begin playback.
- 7 Press the **STOP** button to stop playback

-
- NOTE**
- ❖ If playback finishes before the **STOP** button is pressed, the next file automatically starts to play from the beginning.
 - ❖ Depending on the file size, it may take some time for playback to begin.
-

To pause playback:

- ❖ Press the **PAUSE** button to pause playback.
 - ❖ To resume normal playback, press the **PLAY** or **PAUSE** button.
 - ❖ To locate a specific file, press the **SKIP Reverse** or **SKIP Forward** button repeatedly.
 - ❖ To adjust volume, press **VOLUME (+ -)** buttons.
-

- NOTE** During playback, you can adjust the **SOUND** menu functions from the **Quick Menu**.
-

To set the repeat mode:

- 1 Press the **MENU** button to open the **Quick Menu**.
- 2 Highlight **Repeat**, and press the (**▲/▼** arrow) buttons to select **Off**, **All** or **1**.
- 3 Press the **CH RTN** button to close the Music Player, and then press the **EXIT** button.

Viewing photo files and playing music files at the same time

While viewing photo files, this allows you to listen to music from a list of available files.

- 1 While viewing photos in **Single View** or **Slide Show** mode, press the **MENU** button to open the **Quick Menu**.
- 2 Highlight **Background Music**, and then press the **OK** button. The music list appears.
- 3 Select a music file and press the **OK** button to start playback.
- 4 Press the **RETURN** button twice to return to photo view mode. The music is now playing in the background.

<i>Contents</i>	<i>Description</i>	<i>Description</i>
Photo	Photo list (Multi View)	See page 137
	Sorting	
	To sort the folders and files:	
	1 Press the MENU button to open the Quick Menu from Multi View mode.	
	2 Press the (▲/▼ arrow) buttons to select Sort .	
	3 Press the (◀/▶ arrow) buttons to select Title , New , or Old to set the sorting rule.	
	Title -File sorting rules:	
	1 Unicode priority	
	2 (0, 1-9), capital alphabet (A, B-Z), small alphabet (a, b-z), Chinese	
	3 Increasing order	
	New -From new to old (according to the date and time the picture was taken).	
	Old -From old to new (according to the date and time the picture was taken).	
	Single View mode	
	Slide Show mode	
	Skip to previous/next photo	
	Slide Show Repeat play	
	Slide Show Interval Time selection	

<i>Contents</i>	<i>Description</i>	<i>Description</i>
Music	Music list (Multi View)	See page 136
	Sorting	
	To sort the folders and files:	
	1 Press the MENU button to open the Quick Menu .	
	2 Press the (▲/▼ arrow) buttons to select Sort .	
	3 Press the (◀/▶ arrow) buttons to select Title , New , or Old to set the sorting rule.	
	Playback	
	Pause	
	Stop	
	Skip	
	Repeat play	
	Sound Settings (Adjusting the audio quality)	

NOTE During playback, you can adjust the SOUND menu functions from the Quick Menu.

Setting the sleep timer

You can set the sleep timer to turn off the TV after a set length of time (maximum of 12 hours).

To set the sleep timer using the remote control:

- 1 Press the **SLEEP** button on the remote control to set the length of time until the TV turns off.
- 2 Repeatedly press the **SLEEP** button to increase the time in 10-minute increments, or press the (▲/▼ arrow) buttons to increase or decrease the time in 10-minute increments, (maximum of 12 hours).

To set the sleep timer using the on-screen menus:

- 1 Press the **MENU** button to open the **Setup** menu.
- 2 Highlight **Sleep Timer**.

-
- 3 Press the Number buttons to enter the length of time (maximum of 12 hours) and then press the **OK** button. Or press the (◀/▶ arrow) buttons to increase or decrease in 10-minute increments, (maximum of 12 hours).
-

NOTE If a power failure occurs, the sleep timer setting may be cleared.

To display the time remaining until the TV turns off, press the **SLEEP** button.

NOTE A message displays on-screen when one minute is remaining on the sleep timer.

To cancel the sleep timer, Repeatedly press the **SLEEP** button until it is set to 0 minutes.

Automatic Power Down

The TV can be configured to automatically turn itself off after 4 hours if you do not operate the TV either from the remote control or the TV control panel.

- 1 From the Preferences menu, highlight **Energy Saving Settings**, and then press the **OK** button.
 - 2 Press the (▲/▼ arrow) buttons to select **Automatic Power Down**.
 - 3 Press the (◀/▶ arrow) buttons to select **On/Off**, and then press the **EXIT** button.
-

NOTE When the following features are set, the feature that is set for the nearest time will function.

- ❖ Automatic Power Down
- ❖ Sleep Timer
- ❖ Wallpaper/Auto Power Off
- ❖ Auto shutdown after 1 hour of inactivity (after powering on by On Timer)
- ❖ No signal auto power off (after 14 minutes of no signal)

No Signal Power Down

The TV will automatically turn itself off after 15 minutes when no signal is detected.

- ❖ You can change the setting to Off for the following functions:
 - ❖ Low signal strength of an analog channel (no signal detection)
 - ❖ Only Audio L/R is connected to external input to listen to music through the TV speakers.
- 1 From the Preferences menu, highlight **Energy Saving Settings**, and then press the **OK** button.
 - 2 Press the (▲/▼ arrow) buttons to select **No Signal Power Down**, and then press the **OK** button.
 - 3 Press the (▲/▼ arrow) buttons to highlight the item you wish to change, and then press the (◀/▶ arrow) buttons to select **On/Off**.

NOTE

- ❖ Default setting for each input is On.
- ❖ A warning message appears approximately 1 minute before the TV turns Off.

Using HDMI® CEC

This is a new feature that uses CEC technology and allows you to control Toshiba HDMI® CEC compatible devices from the TV remote control via an HDMI® connection.

When the Enable HDMI® CEC in the HDMI® CEC Setup menu is set to On, the following HDMI® CEC functions are enabled.

HDMI® CEC playback device (DVD player, etc.) control

With your TV's remote control, or using the HDMI® CEC Player Control menu, you can control the connected HDMI® CEC playback device you are watching.

Available remote control key functions:

<i>Button:</i>	<i>Description:</i>
PLAY	Begin playback
STOP	Stop playback
PAUSE	Pause the picture during play or record mode
SKIP Forward	Skip Forward

<i>Button:</i>	<i>Description:</i>
SKIP Reverse	Skip backward
FF	Fast forward
REV	Rewind/reverse
▲/▼/◀/▶	Navigates menu options
OK	Enters menu options
CANCEL	Return to the previous menu

NOTE These functions depend on the devices connected.

HDMI® CEC Player Control menu functions:

- 1 Press the **MENU** button, and then open the **Preferences** menu.
- 2 Highlight **HDMI® CEC Player Control**, and then press the **OK** button.

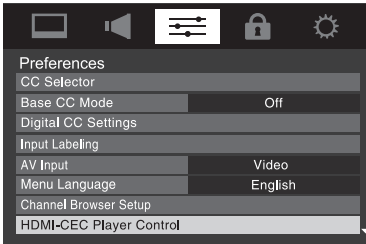

(Sample Image) HDMI® CEC Player Control screen

- 3 Press the (▲/▼ arrow) buttons to select the item you wish to control, and then press the **OK** button.

<i>Item:</i>	<i>Description:</i>
Power	Turns the selected device On/Off
Root Menu	Accesses the top menu of the selected device
Contents Menu	Accesses the contents list when you press the OK button. At this time, the HDMI® CEC Player Control menu disappears.
Setup Menu	Accesses the Setup menu of a DVD player
Top Menu	Accesses the top menu of a DVD
Menu	Accesses the menu of a DVD

- NOTE** These functions depend on the devices that are connected. The HDMI® CEC Player Control item will be grayed out in the following conditions:
- ❖ A non-HDMI® input is currently selected.
 - ❖ The Enable HDMI® CEC item is set to Off.
 - ❖ The connected CEC device is not a playback or recording device.
-

HDMI® CEC input source selection

If a HDMI® CEC device with HDMI® switching capability (e.g. Audio Receiver) is connected to the HDMI® input, you can select another HDMI® CEC device that is connected to the master HDMI® device using the TV's INPUT button, see [“Selecting the video input source” on page 59](#).

VOLUME and MUTE controls of Audio Receiver

With your TV's remote control, you can adjust or mute the sound volume of the Audio Receiver.

- ❖ **VOL (+ -)** buttons adjust the volume level.
- ❖ **MUTE** button turns off the sound.

To use this function:

- ❖ Set **Speaker Preference** to **Audio Receiver** in the **HDMI® CEC Setup** menu.
 - ❖ Confirm that a connected HDMI® CEC device (such as DVD player, etc.) is selected for the Audio Receiver input source.
-

- NOTE** These functions depend on the device connected.
-

Other HDMI® CEC functions

When the **Enable HDMI® CEC** and each item in the **HDMI® CEC Setup** menu are set to **On**, the following functions will be enabled.

<i>Item:</i>	<i>Description:</i>
TV Auto Input Switch	If a connected HDMI® device starts playing video or audio, the TV will automatically switch to the appropriate HDMI® input.
TV Auto Power	If a HDMI® CEC device is turned on, the TV turns on automatically.
Device Auto Standby	If the TV is turned off the TV will send a message to turn off all of the HDMI® CEC devices connected to the TV.
Speaker Preference	From this item, you can set your audio output preference to the TV speakers or the audio receiver speakers. When this item is set to Audio Receiver, the TV remote can be used to adjust or mute the volume of the audio. This item will be grayed out unless a HDMI® CEC compatible audio receiver is connected.

NOTE

When you turn on the Audio Receiver, change its input source or adjust the sound volume, the sound will be output from the audio receiver's speakers even if TV Speakers has been selected. Turn the TV off and on again to output the sound from the TV speakers.

To set the HDMI® CEC Setup:

- 1 From the Setup menu, highlight **HDMI® CEC Setup** and press the **OK** button.
- 2 Press the (▲/▼ arrow) buttons to highlight **Enable HDMI® CEC**.
- 3 Press the (◀/▶ arrow) buttons to select **On**.

NOTE

If you select Enable HDMI® CEC Off, the other items will be grayed out.

- 4 Press the (▲/▼ arrow) buttons to highlight the **HDMI® CEC Setup** item you wish to use, and press then press the (◀/▶ arrow) buttons to select **On** or the desired mode.
 - ❖ **TV Auto Input Switch:** On/Off
 - ❖ **TV Auto Power:** On/Off
 - ❖ **Device Auto Standby:** On/Off
 - ❖ **Speaker Preference:** TV Speakers/Audio Receiver

- 5 To save the new settings, highlight **Done** and press the **OK** button. To revert to the factory defaults, highlight **Reset** and press the **OK** button.

Displaying TV status information

To display TV status information:

- ❖ Press the **INFO** button on the remote control.

The following information will be displayed (if applicable):

- ❖ Current input (**ANT/CABLE**, **Video**, etc.)
- ❖ If ANT/CABLE is the current input, either “CABLE” (for cable TV) or “ANT” (for over-the-air broadcasts).
- ❖ Channel number (if in **ANT/CABLE** mode)
- ❖ Channel label, if applicable
- ❖ Digital signal strength indicator (bar graph in lower right corner of box; for ATSC signals only)
- ❖ Stereo, Mono, or SAP audio status (when in HDMI® input mode, PCM)
- ❖ Video resolution
- ❖ Aspect ratio of incoming video signal (4:3 or 16:9)
- ❖ V-Chip rating status
- ❖ GameTimer (if set)

To close the screen (except ANT/CABLE input), press the **INFO** button again.

The following additional information will display for ANT/CABLE input, if applicable:

- ❖ Title
- ❖ Duration
- ❖ Detailed description

To display the next program's information for digital channels, press the **INFO** button again. Pressing the **INFO** button a third time will remove the entire banner.

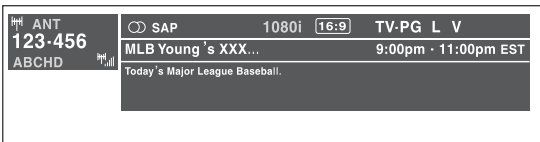

(Sample Illustration) Banner

NOTE The location of the banner can be moved to the top or bottom of the screen by pressing ▲ or ▼ while the INFO display is on-screen.

Understanding the auto power off feature

The TV will automatically turn itself off after approximately 15 minutes if it is tuned to a vacant channel or a station that completes its broadcast for the day.

- NOTE**
- ❖ If you want to set this feature to Off, see [“No Signal Power Down” on page 108](#).
 - ❖ If it is possible that you will be away from the TV for an extended period of time, you should unplug the power cord.
-

Understanding the last mode memory feature

If the power is cut off while you are viewing the TV, the Last Mode Memory feature automatically turns on the TV when the power is resupplied.

NOTE If it's possible, and you will be away from the TV for an extended period of time you should unplug the power cord.

Chapter 7

Using the TV's Advanced Features

Using the advanced picture settings

Dynamic Contrast

Dynamic Contrast detects changes in picture quality that affect the appearance of your contrast settings and then automatically adjusts the video.

To select Dynamic Contrast preference:

- 1 From the Picture menu, highlight **Picture Settings** and press the **OK** button.

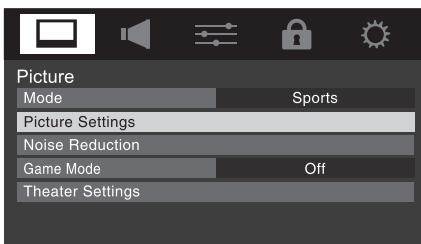

(Sample Image) Dynamic Contrast screen

- 2 Highlight **Advanced Picture Settings**, and then press the **OK** button.
- 3 Press the (**▲/▼** arrow) buttons to select **Dynamic Contrast**.

- 4 Press the (◀/▶ arrow) buttons to select **High, Middle, Low** or **Off**.

Static Gamma

The static gamma feature lets you adjust the levels of black in the picture.

To adjust the static gamma settings:

- 1 Press the **MENU** button to open the **Picture** menu.
- 2 Highlight **Picture Settings**, and then press the **OK** button.
- 3 Highlight **Advanced Picture Settings**, and then press the **OK** button.
 - ❖ In the **Static Gamma** field, press the (◀/▶ arrow) buttons to adjust the Static Gamma. (The adjustment range is within ± 5 from center).
 - ❖ If the setting is decreased, the detail of black colors is decreased.
 - ❖ If the setting is increased, the detail of black colors is increased.
- 4 To save the new settings, highlight **Done**, and then press the **OK** button.
- 5 To revert the factory defaults, highlight **Reset**, and then press the **OK** button.

NOTE

Note: If you select one of the factory-set picture modes (Dynamic, Standard, Movie or PC) and then change the Static Gamma setting, the picture mode automatically changes to Preference.

Color temperature

You can change the quality of the picture by selecting from three preset Color Temperatures (**Cool, Medium, and Warm**), as described below.

<i>Mode:</i>	<i>Picture Quality:</i>
Cool	blueish
Medium	neutral
Warm	reddish

- 1 Press the **MENU** button to open the **Picture** menu.

- 2 Highlight **Picture Settings**, and then press the **OK** button.
 - 3 Highlight **Advanced Picture Settings**, and then press the **OK** button.
 - 4 Highlight **Color Temperature**, and then press the **OK** button.
 - 5 In the **Color Temperature** field, press the (◀/▶ arrow) buttons to select the mode you prefer (**Cool**, **Medium**, or **Warm**).
 - 6 Press the (▲/▼ arrow) buttons to select either **B Drive** or **G Drive**, and then press the (◀/▶ arrow) buttons to adjust the settings:
 - ❖ **B Drive:** press the (▶ arrow) button to make the picture blueish.
 - ❖ **G Drive:** press the (▶ arrow) button to make the picture greenish.
-

NOTE

The B Drive and G Drive settings are connected to the Color Temperature settings and will change based on which setting is selected in step 5 above.

- 7 To save your new settings, highlight **Done**, and then press the **OK** button.
 - 8 To revert to your original settings, highlight **Reset**, and then press the **OK** button.
-

NOTE

If you select one of the factory set picture modes (Dynamic, Standard, Movie, or PC) and then change the Color Temperature mode, the picture mode automatically changes to Preference.

CableClear® digital Noise Reduction

The CableClear® digital Noise Reduction feature allows you to reduce visible interference in your TV picture. This may be useful when receiving a broadcast with a weak signal (especially a Cable channel) or playing a noisy video cassette or disc.

To change the CableClear settings:

- 1 Press the **MENU** button to open the **Picture** menu.
- 2 Highlight **Noise Reduction**, and then press the **OK** button.
- 3 In the **CableClear** field, select your desired setting.

- NOTE**
- ❖ If the current input is ANT/CABLE or VIDEO, the menu will display the text "CableClear". The available selections are Off, Low, Middle, and High.
 - ❖ If the current input is ColorStream® HD, HDMI 1 or HDMI 2, the menu will display the text "DNR". The available selections are Off, Low, Middle, and High. Low, Middle, and High will reduce the noise in varying degrees, from lowest to highest, respectively.

- 4 To save your new settings, highlight **Done**, and then press the **OK** button.
- 5 To revert to your original settings, highlight **Reset**, and then press the **OK** button.

MPEG Noise Reduction

The MPEG Noise Reduction feature allows you to reduce visible interference caused by MPEG compression. Choices for MPEG Noise Reduction are Off, Low, Middle, and High. Off is automatically selected when this feature is disabled ("grayed out").

To select the MPEG Noise Reduction level:

- 1 Press the **MENU** button to open the **Picture** menu.
- 2 Highlight **Noise Reduction**, and then press the **OK** button.
- 3 Press the (▲/▼ arrow) buttons to highlight the **MPEG Noise Reduction** field **G Drive**, and then press the (◀/▶ arrow) buttons to select either **Off**, **Low**, **Middle**, or **High**.
- 4 To save your new settings, highlight **Done**, and then press the **OK** button.
- 5 To revert to your original settings, highlight **Reset**, and then press the **OK** button.

Using the Game Mode feature

You can use the Game Mode feature for shorter frame delays when playing a video game requiring split-second timing between the on-screen display and input from the controller (such as music creation and high-action games).

This feature is more effective for 480i and 1080i input signals.

NOTE To use the Game Mode feature, the current video input must be Video, ColorStream® HD, HDMI 1 or HDMI 2. The Game Mode cannot be turned on when any other video input, other than the above mentioned is selected.

To turn on Game Mode:

- 1** Press the **MENU** button to open the **Picture** menu.
- 2** Press the (▲/▼ arrow) buttons to select **Game Mode**.
- 3** Press the **OK** button to toggle Game Mode **On/Off**.

To turn off Game Mode, toggle to **Off** in step 3 above, change the video input, or turn the TV off and then on again.

NOTE You can change the video input by pressing INPUT on the remote control.

Chapter 8

Basic Disc Playback

Disc playback

This section shows you the basics on how to play a disc.

Basic playback (DVD/VCD/CD)

- 1 Press the **POWER** button on the TV control panel or on the remote control.

The Power LED on the front of the LED TV/DVD combination changes to green. It may take approximately 10 seconds for a picture to appear on-screen. When using an amplifier, switch on the amplifier.

- 2 Press the **TV/DVD** button on the remote control to switch to DVD mode.

The DVD start-up screen appears.



(Sample Image) DVD start-up screen

- 3 Hold the disc by its edges and load it in the disc slot with the label side facing forward. The prompt “Close” changes to “Loading” and then playback begins.

NOTE

DO NOT touch the surface of the disc. This may leave a smudge that can cause playback errors.

If the disc has its own menu, it will be displayed on-screen. Press the (**▲/▼/◀/▶** arrow) buttons on the remote control to navigate the disc menu, then press the **OK** button to implement the selected menu option.

To adjust playback volume, press the **VOL (+ -)** buttons.

To temporarily suspend disc playback (still mode), press the **PAUSE** button.

To continue playback from still mode, press the **PLAY** button.

To stop playback, press the **STOP** button.

Playback resume function:

Your LED TV/DVD combination supports playback resume function.

If you stopped the disc playback before it is completed, the LED TV/DVD combination records the stop point.

Press the **PLAY** button to resume playback on the stop point. If you press the **STOP** button twice in quick succession or unload the disc, the LED TV/DVD combination will clear the stop point.

Higher quality picture:

High resolution pictures on some discs may occasionally cause noise on the picture display. If this is the case, reduce the **Sharpness** setting under the Picture Settings menu.

NOTE

- ❖ Keep your fingers well clear of the disc slot when a disc is loading or unloading. Failure to do so may cause serious personal injury.
 - ❖ Do not move the TV during playback. Doing so may damage the disc.
 - ❖ When a disc is inserted when the TV is not in DVD mode, the TV will automatically switch to DVD mode.
-

This indicates the kind of disc that can employ the function described under that heading.

- ❖ **DVD:** You can use this function with DVDs.
- ❖ **VCD:** You can use this function with Video CDs.
- ❖ **CD:** You can use this function with Audio CDs and CD-R/RW discs.

Removing a disc

- 1 Press the **EJECT** button on the TV control panel or on the remote control.
- 2 Wait for the disc to be ejected and then remove the disc from the slot.

Disc playback reminders

- ❖ If the LED TV/DVD combination does not operate properly, static electricity build-up may be the cause. Turn off the LED TV/DVD combination, then disconnect the power cord from the AC outlet. Reconnect the power cord, then press the **POWER** button to turn on the LED TV/DVD combination again.
- ❖ If an incompatible disc is loaded, one of the following error messages appears on-screen: “Incorrect Disc,” “Wrong Region,” or “Please Enter Pws.” If this is the case, check your disc again.
- ❖ In some instances the LED TV/DVD combination may take a few minutes to start disc playback.

- ❖ When you load a disc with the playback side facing backward, the message, “Loading” appears on the screen. It will be replaced by the message, “Incorrect Disc.” Eject the disc and load it again making sure the playback side is now facing forward.
- ❖ The playback resume function may not work on some discs.
- ❖ Some DVDs may have fixed playback operations designed by the DVD manufacturer. Your LED TV/DVD combination follows this fixed playback design. In such cases, some playback features may not be available. You may refer to the instructions accompanying the DVD.
- ❖ Do not put any objects other than compatible discs in the disc slot. Doing so may cause damage to the LED TV/DVD combination.
- ❖ There may be a few seconds between the action of pressing a button and the function it activates.
- ❖ Do not use 8cm DVD or CD Discs. These formats are not supported.

Playback navigation

Playing in fast reverse or fast forward direction (DVD/VCD/CD)

Press the **REV** button or the **FF** button during playback.

- ❖ **REV**: Fast reverse playback
- ❖ **FF**: Fast forward playback

Each time you press the **REV** button or the **FF** button, the playback speed changes.

To resume normal playback, press the **PLAY** button.

- NOTE**
- ❖ The sound is muted during reverse and forward scan.
 - ❖ The playback speed may differ depending on the disc.
 - ❖ You can use fast reverse/fast forward playback for MP3 and WMA discs.
-

Playing frame by frame (DVD/VCD)

Press the **PAUSE** button during playback. Each time you press the **PAUSE** button, the picture advances one frame.

To resume normal playback, press the **PLAY** button.

NOTE The sound is muted during frame by frame playback.

Playing in slow motion (DVD/VCD)

Press the **SLOW** button during playback. Each time you press the **SLOW** button, the slow motion speed changes.

To resume normal playback, press the **PLAY** button.

NOTE The sound is muted during slow motion playback.

Locating a chapter or track (DVD/VCD/CD)

Press the **SKIP Forward** button or the **SKIP Reverse** button repeatedly to locate the next or previous chapter or track you want to play.

- ❖ **SKIP Forward:** To locate succeeding chapters or tracks. Playback starts from the beginning of the selected chapter or track.
- ❖ **SKIP Reverse:** Playback starts from the beginning of the current chapter or track.

When you press the **SKIP Reverse** button twice in quick succession, or one time within 3 seconds from the beginning of the current chapter or track, playback starts from the beginning of the preceding chapter or track.

Chapter 9

Advanced Disc Playback

Zoom function/Scene navigation

You can change the viewing scale of a picture by using the Zoom function. Once the image has been rescaled, use the (▲/▼/◀/▶ arrow) buttons to pan the image.

Scene navigation options differ depending on the kind of disc. DVDs use the title, chapter or record time to locate the start point for playback. Audio CDs and Video CDs use the record time or track number.

Using Zoom (DVD/VCD)

- 1 Press the **ZOOM** button during playback. The view will zoom into the center of the image. Each time you press the **ZOOM** button, the scale increases by the following values: x2, x3, x4.

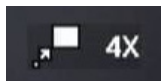

(Sample Image) Disc zoom

- 2 Press the (▲/▼/◀/▶ arrow) buttons to pan the scene and view different sections of the picture.
- 3 To return to normal view, in Zoom mode, press the **ZOOM** button repeatedly until picture size returns to normal viewing.

- NOTE**
- ❖ You can use the Pause, Slow and Search playback functions in Zoom mode.
 - ❖ Zoom function may not apply to some discs.

Locating a specific scene

- 1 Press the **JUMP** button during playback, still or stop mode.

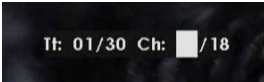

(Sample Image) Disc Jump - Title

- 2 Press the (◀/▶ arrow) buttons to select a navigation option.

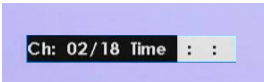

(Sample Image) Disc Jump - Chapter

- 3 Use the Channel Number buttons (0-9) to enter a value for the chapter number of the DVD option you selected.

Number entries must be entered in a two digit format, such as 08 or 09 instead of 8 or 9, while using this feature.

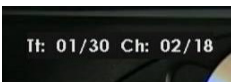

(Sample Image) Disc Jump - Chapter 12

If you input a wrong number, wait approximately 8 seconds for the screen to disappear and then press the **JUMP** button again. Refer to the disc package to check the correct number.

- 4 The DVD will change to the selected chapter after the chapter numbers are entered. For VCD, you must press the **PLAY** button or the **OK** button to start playback.

For Audio CDs and Video CDs, you can locate a scene by track number or record time.

VCD mode:



(Sample Image) Disc Jump - VCD mode

CD mode:



(Sample Image) Disc Jump - CD mode

NOTE

- ❖ When you use title navigation, playback starts from the first chapter of the selected title.
 - ❖ For PBC-enabled VCDs, turn off the PBC function first before using the Jump function.
 - ❖ Scene navigation may not apply to some discs.
-

Scene bookmark

Scene bookmarks refer to specific points in the playback range that have been marked for later access. You can create up to twelve markers per disc.

NOTE

The saved scene bookmarks are only accessible during the current session. Once you eject the disc or turn off the LED TV/DVD combination, all bookmarks will be cleared.

Bookmarking a scene (DVD/VCD)

- 1 During playback, press the **MARKER** button at the scene you would like to place the bookmark.



(Sample Image) Disc scene bookmarking

- 2 Press the (◀/▶ arrow) buttons to select a blank marker, and then press the **PLAY** button. Repeat these steps to save twelve more bookmarks.

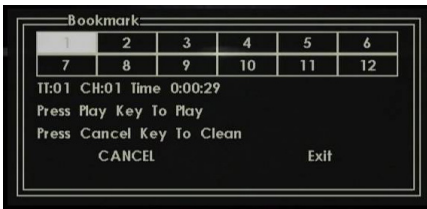

(Sample Image) Disc scene bookmarking

- 3 Press the **MARKER** button to exit and close the bookmark window. Select **Cancel** to cancel the bookmark and exit the screen.

NOTE

- ❖ In some cases, subtitles for the marked scene may not display.
- ❖ Bookmarking a scene may not apply to some discs.

Viewing a scene bookmark (DVD/VCD)

- 1 Press the **MARKER** button to open the bookmark window.
- 2 Press the (◀/▶ arrow) buttons to select the saved marker.

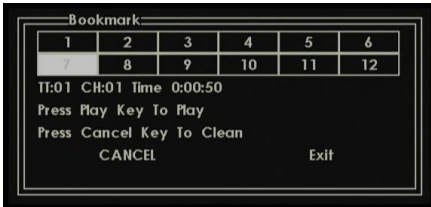

(Sample Image) Disc scene bookmarking

- 3 Press the **PLAY** button to start playback on the scene saved in the selected bookmark.

To delete a scene bookmark, perform steps 1 and 2 above, and then press the **EXIT** button.

Repeat playback/A-B repeat

You can choose to repeat DVD playback by title or chapter. For Audio CDs and Video CDs, you can repeat a single track or the entire disc.

The A-B repeat function lets you repeat a specific section between two set points. This section will be played repeatedly until you turn off the A-B repeat mode.

The repeat playback mode is not applicable to PBC-enabled Video CDs.

Enabling repeat playback (DVD/VCD)

- ❖ DVD:
 - ❖ Press the **PLAY MODE** button repeatedly to select a repeat mode. It can either be by **Chapter**, **Title**, or **All**.

The LED TV/DVD combination automatically starts repeat playback after finishing the current title or chapter.



(Sample Image) Disc enabling repeat playback

VCD:

- ❖ Press the **PLAY MODE** button repeatedly to select a repeat mode. The modes are listed by **Track**, **All**, or **Off**.



(Sample Image) Disc enabling repeat playback

NOTE If you set the repeat mode during stop mode, press the **PLAY** button to start Repeat playback.

To resume normal playback, select **Off** in the step above.

NOTE The Repeat playback function may not apply to some discs.

Enabling A-B repeat mode (DVD/VCD/CD)

- 1 During playback, press the **REPEAT A-B** button at the point where you would like the playback loop to begin. This sets your “A” point.

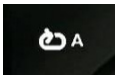

(Sample Image) Disc A-B repeat mode

- 2 When the playback reaches the point where you would like the playback loop to stop, press the **REPEAT A-B** button again. This sets your “B” point.



(Sample Image) Disc A-B repeat mode

The section between points A and B will be played repeatedly in a loop until you turn off the Repeat A-B mode.

To resume normal playback, press the **REPEAT A-B** button until "A-B repeat" disappears on the screen.

- NOTE**
- ❖ In some cases, subtitles for the repeated scene may not display.
 - ❖ The A-B repeat mode may not apply to some DVD scenes.
 - ❖ The A-B repeat mode is not applicable to interactive DVDs and JPEG CDs.
-

Scene angle/Title selection/DVD menu

Changing the scene angle (DVD)

- 1 Press the **ANGLE** button during playback.
 - 2 Press the **ANGLE** button repeatedly until the preferred scene angle is displayed.
-

- NOTE** Depending on the DVD, you may not be able to change the scene angle even if multi-angle data are recorded on the disc.
-

Selecting a DVD title (DVD)

Some DVDs contain two or more titles. If this is the case, you can select a particular title for playback.

- 1 Press the **TOPMENU** button during playback to display the title menu.
 - 2 Press the (**▲/▼/◀/▶** arrow) buttons to select the preferred title.
 - 3 Press the **PLAY** button or the **OK** button to start playback.
-

- NOTE**
- ❖ Title selection may not apply to some DVDs.
 - ❖ The title menu may simply be referred to a "menu" or "title" in the instructions supplied with the DVD.
-

DVD menu (DVD)

Some DVDs have an encoded menu that allows users to select a specific disc content, enable a particular DVD feature (e.g. subtitle or sound track language), or choose a particular title (for multi-title DVDs).

- 1 Press the **DVD MENU** button during playback.

- 2 Press the (▲/▼/◀/▶ arrow) buttons to select a DVD menu item, and then press the **OK** or **PLAY** button to access it. Use the same buttons to enable an option for the selected item. Repeat this step to configure other menu options.
- 3 Press the **DVD MENU** button again to resume playback on the scene that was playing when you pressed the **DVD MENU** button.

NOTE

Depending on the DVD, you may not be able to resume playback from the same scene that was playing when you pressed the DVD MENU button.

Sound track language/Audio channel/Subtitle

Selecting a sound track language (DVD)

You can select the sound track language when you play a multilingual DVD.

During playback, press the **AUDIO** button repeatedly until the preferred language track is selected.

Selecting the audio channel (VCD)

During playback, press the **AUDIO** button repeatedly until the preferred audio channel is heard. The available options are **Stereo**, **Left**, **Right**, and **Mix**.

NOTE

- ❖ If the preferred language option is not heard after selecting it for several times, that language is not recorded on the disc.
 - ❖ The sound track language selected is only applicable for the current session. When you stop playback and try to play the disc again, the default language track will be used.
-

Viewing subtitles (DVD)

When playing back a disc recorded with subtitles, you can select the subtitle language or turn the subtitle off.

To view subtitles:

Press the **SUBTITLE** button repeatedly during playback until the preferred language is selected.

The Subtitle prompt disappears after a few seconds.

To disable subtitles:

Press the **SUBTITLE** button until **Off** appears.

- NOTE**
- ❖ Not all DVDs have encoded subtitles.
 - ❖ The subtitle selection may revert to the default language when you stop playback and try to play the DVD again.
 - ❖ In some cases, the selected subtitle may not display immediately.

Playback information/VCD playback control

Viewing the playback info (DVD/VCD)

Press the **DISPLAY** button during playback.

DVD mode:



(Sample Image) Viewing the playback info - DVD mode

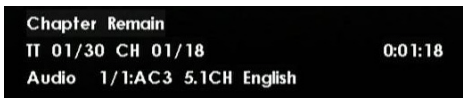

(Sample Image) Viewing the playback info - DVD mode

VCD mode:



(Sample Image) Viewing the playback info - VCD mode

To close the information display, press the **DISPLAY** button until "Display Off" appears.

- NOTE** Depending on the disc, this operation may not be available.

Enabling the Playback Control (PBC) function (VCD)

- 1 In the stop mode, press the **DVD MENU** button to select the PBC ON/OFF.



(Sample Image) Enabling the PBC function

When enabled, PBC allows interactive Video CD playback using the remote control.

MP3, WMA, JPEG, and Audio CD operation

This LED TV/DVD combination can play MP3, WMA, and JPEG files recorded on a DVD/CD-R or DVD/CD-RW disc. To create the MP3/WMA/JPEG disc, you need a Windows PC with a DVD/CD-RW drive and file encoding software. You must use a Windows® computer to create the MP3/WMA/JPEG disc.

This LED TV/DVD combination requires discs/recordings that meet certain technical standards in order to achieve optimal playback quality. There are many different types of recordable disc formats (including CD-R discs containing MP3 or WMA files). Not all recordable discs will produce optimal playback quality. The technical criteria set forth in this User's Guide are meant only as a guide. Use of DVD/CD-RW discs for recording MP3 files is not recommended.

You must obtain any required permission from copyright owners to download or use copyrighted content. Toshiba can not and does not grant such permission.

MP3/WMA/JPEG/Audio CD information

MP3/WMA/JPEG CD playback reminders

- ❖ Make sure the file name of the MP3, WMA, and JPEG files in the CD includes the 3-character file extension (“mp3”, “wma”, “jpg”) to make it compliant with the ISO 9660 standard.
- ❖ This LED TV/DVD combination can read 2000 files per disc. If a disc has more than 2000 files, it reads the first 2000 files, while the remaining files will be omitted.
- ❖ To play the files in sequence based on the recorded order:
 - ❖ Use an encoding software that records data alphabetically or numerically.
 - ❖ Include a two- or three-digit number prefix on the file name (ex. “01” “02” or “001” “002”).

- ❖ Refrain from making too many sub-folders.
- ❖ It may take more than one minute for this LED TV/DVD combination to read MP3, WMA, and JPEG files depending on the disc structure.
- ❖ Audio files recorded using the Joliet Recording Specification can be played back in this LED TV/DVD combination. The file name is displayed (up to 20 characters). Longer file names will be condensed.
- ❖ Music recorded based on the Joliet Recording Specification can be played back, the file name is displayed (within 20 letters) on the screen. Long file names will be condensed.
- ❖ This LED TV/DVD combination does not support data disc burned using the Apple Mac OS (Hierarchical File System, HFS format).
- ❖ MP3/WMA/JPEG CDs cannot be used for recording purpose.

File name display reminders

- ❖ The maximum number of characters for file name display is 20.
- ❖ Only the following characters will be displayed: A through Z (both upper and lower case), 0 through 9, and the underscore symbol (_).
- ❖ Non-supported characters will be replaced with a hyphen.

MP3/WMA/JPEG CD limitations

- ❖ Depending on the recording conditions, some MP3/WMA/JPEG CDs cannot be played back in your LED TV/DVD combination.
- ❖ Only MP3, WMA, and JPEG files recorded in the CD-R/RW disc will be played. Other files will not be read nor displayed.

MP3/WMA file encoding information

- ❖ MP3:
 - ❖ File format: MPEG-1 Audio
 - ❖ Sampling frequency: 32 kHz, 44.1 kHz, 48 kHz
 - ❖ Bit rate: 32 to 320 kbps (constant bit rate or variable bit rate)

The recommended recording setting for high-quality sound is 44.1 kHz sampling frequency and 128 kbps constant bit rate.

- ❖ WMA:
 - ❖ File format: WMA version 7 or 8
 - ❖ Sampling frequency: 32 kHz/48 kbps, 44.1 kHz/48 to 92 kbps, 48 kHz/128 to 192 kbps A file recorded in mono (48 kHz/48 kbps) is not supported by this LED TV/DVD combination.

About the file browser



(Sample Image) File browser (CD)

File icons:



(Sample Image) File browser (CD)

If a CD contains a mixture of MP3, WMA and JPEG files, and the **PLAY** button is pressed without selecting a file, playback automatically begins starting from the first file in the list.

Setting the file type listing:

You can choose the type of files listed in the file browser.

- 1 Press the (▶ arrow) button to highlight to the **Option** panel.
- 2 Press the (▲/▼ arrow) buttons to highlight **Select files**, and then press the **OK** button.
- 3 Press the (▲/▼ arrow) buttons to select a file type from the list **Audio** or **Photo**.
- 4 Press the **OK** button to add or remove the check mark next to each file type. The checked file type is displayed in the file browser.
- 5 Press the (◀ arrow) button twice to move the selection highlight back to the file list.

Viewing image files in thumbnail mode:

You can change the browser's view mode from list mode to thumbnail mode. This is convenient when browsing for JPEG files.

- 1 Press the **DVD MENU** button during JPEG playback.
- 2 Press the (**▲/▼/◀/▶** arrow) buttons to select an image file.
- 3 Press the **OK** button to play the image file.

To return the browser to list mode, press the **STOP** button.

To view the previous or next thumbnail page, press **SKIP REVERSE** or **SKIP BACKWARD**.

Playing an audio file

- 1 Load an MP3/WMA/Audio CD in the disc slot. The file browser appears on-screen. Press the (**▲/▼** arrow) buttons to select the audio file you wish to play. Press the **PLAY** button or the **OK** button to start playback.



(Sample Image) Playing an audio file

- 2 Press the (**▲/▼** arrow) buttons to select another audio file for playback.



(Sample Image) Playing an audio file

- 3 Press the **PLAY** button or the **OK** button to start playback.
To stop playback, press the **STOP** button.

- NOTE**
- ❖ If the current directory has more than eight files, press the (▲/▼ arrow) buttons to scroll the file list.
 - ❖ To see folder contents, select a folder and then press the **OK** button.
 - ❖ To return to the root directory, press the **RETURN** button or select "Go Up" icon and then press the **OK** button.
 - ❖ In thumbnail mode, press the **PIC SIZE** button repeatedly to change the thumbnail size.
 - ❖ The Repeat/Programmed playback modes can be enabled during Audio CD, MP3, or WMA playback.

Viewing a JPEG file

- 1 Load a disc containing JPEG files in the disc slot. The file browser appears on the screen.
- 2 Press the (▲/▼ arrow) buttons to select an image file to view. A preview of the selected file is displayed in the Preview panel.
- 3 Press the **OK** button or the **PLAY** button.
The selected image is displayed in full-screen mode. The Slide Show mode is enabled automatically. If you wish stop the Slide Show mode, press the **PAUSE** button.
- 4 Press the **SKIP Reverse** or **SKIP Forward** button to view the previous or next image file in the current directory.

To rotate an image:

Press the **ANGLE** button repeatedly until the preferred angle is obtained. The image angle is adjusted in 90° increments.

The current angle setting is shown on the screen: **90°**, **180°**, **270°** or **No rotation**.

To magnify an image, press the **ZOOM** button repeatedly until the image is displayed in the preferred scale.

The current zoom setting is indicated by the following: 100%, 125%, 150%, 200%, 50%, 75%.

To return to normal view, press the **ZOOM** button repeatedly until **ZOOM** disappears.

Viewing a slide show

If there are multiple JPEG files in the selected directory, you can view them in a slide show. The instructions on how to enable the slide show feature and set the interval period between pictures are listed below.

- 1 Open the file folder containing the JPEG files you want to include in the slide show.
- 2 Press the ($\blacktriangle/\blacktriangledown$ arrow) buttons to select the file you want to be the starting image for the slide show.

A preview of the selected file is displayed in the Preview panel.

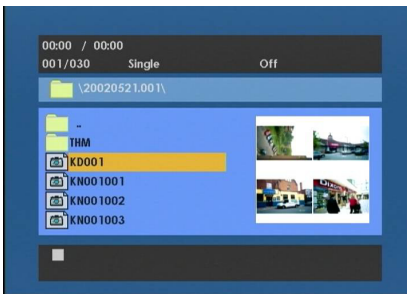

(Sample Image) Viewing a slide show

- 3 Press the **OK** button or the **PLAY** button.

The selected image is displayed in full-screen mode.

When the slide show is completed, the file browser appears.

To view the previous or next image in the slide show, press the **SKIP Reverse** or **SKIP Forward** button.

To temporarily stop the slide show, press the **SKIP Reverse** or **SKIP Forward** button.

To stop the slide show, press the **STOP** button. The file browser appears.

- NOTE**
- ❖ The Rotate mode is available in regular JPEG viewing and slide show modes.
 - ❖ The A-B repeat mode is not available when viewing JPEG images.
 - ❖ During a slide show, the interval time between images may increase if the file size is too big.
 - ❖ When an image exceeds 5760 x 3840 pixels, the image display can appear cropped. This applies when viewing the image in the Preview panel of the file browser; or when in the thumbnail, full-screen or slide show modes.

MP3, WMA, JPEG, and Audio CD playback modes

You can choose to repeat CD playback by track or the entire disc.

- NOTE** These playback modes are only applicable during the current session. Once you eject the disc or turn off the LED TV/DVD combination, these modes will be disabled.

Enabling repeat playback

- 1 During stop mode, press the **PLAY MODE** button repeatedly to select a repeat mode. The modes are **Single**, **Repeat One**, **Repeat Folder**, **Folder**.



(Sample Image) Enabling repeat playback

- 2 Press the **PLAY** button.
The LED TV/DVD combination automatically starts repeat playback from the current track.

To resume normal playback, select **Folder** in step 1 above.

Programming the playback sequence

- 1 In the file browser, press the **MARKER** button to open the file list



(Sample Image) Programming the playback sequence

NOTE You can not select the same file twice or more. A JPEG file cannot be added to a playlist.

- 2 Press the (**▲/▼** arrow) buttons to select a file, and then press the **OK** button to add it for inclusion in the programmed playlist.
Repeat step 1 to remove any other files you wish to add in the programmed playlist.



(Sample Image) Programming the playback sequence

- 3 Press the **MARKER** button,
The programmed files appear in the Playlist.



(Sample Image) Programming the playback sequence

- 4 In the programmed file list, press the ($\blacktriangle/\blacktriangledown$ arrow) buttons to select a file, and then press the **PLAY** button to start playback.
To remove a file from the programmed list:
 - 1 In the Playlist, press the ($\blacktriangle/\blacktriangledown$ arrow) buttons to select the file you wish to remove, and then press the **CANCEL** button.
 - 2 Repeat step 4 to mark any other files you wish to remove from the list.

Customizing disc playback

You can customize the disc playback settings to suit your preferences.

Configuring the disc playback settings (DVD/VCD/CD)

- 1 In DVD mode, press the **SETUP** button during stop mode.

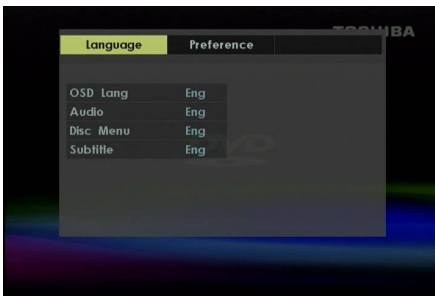

(Sample Image) Configuring disc playback settings

- 2 Press the (◀/▶ arrow) buttons to select a setup tab, and then press the (▼ arrow) button.

The first setup option is highlight.

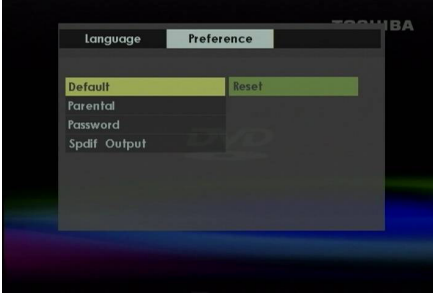

(Sample Image) Configuring disc playback settings

- 3 Press the (▲/▼ arrow) buttons to select the setup option you wish to customize.
- 4 Press the (▶ arrow) or the **OK** button to display a list of available option settings.
- 5 Press the (▲/▼ arrow) buttons to select an option setting, and then press the **OK** button to apply and save the setting.
- 6 To configure another option on the same setup tab, repeat steps 3–5.
- 7 To configure an option on another tab, press the (◀ arrow) button, and then use the (◀/▶ arrow) buttons to select a setup tab.
- 8 Repeat steps 3-5 to configure the preferred option.
- 9 To close the Setup screen, press the **SETUP** button.

Disc playback setup

	Option	Description	Page
Language	OSD Language	Selects the language for the setup screen display.	145
	Audio	Selects the audio language for disc playback.	145
	Disc Menu	Selects the language for the DVD menu display.	145
	Subtitle	Selects the subtitle language.	145
Preference	Default	Resets to default.	144
	Downmix	Selects the downmix to options like Stereo.	144
	Parental	Sets the restriction level for allowable disk content.	146
	Password	Changes the access password for the parental control setting.	147
	Spdif Output	Sets the sound format of the digital output.	147

NOTE These setup settings are retained in the LED TV/DVD combination's memory. It remains active even if the power is turned off.

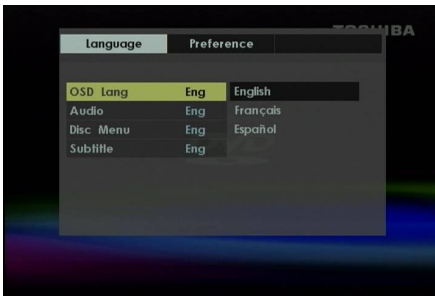

(Sample Image) Playback settings

OSD Language

Select the language for the DVD and Setup menu display. The available options are English, French, or Spanish.

Subtitle/Audio

Select the language you wish to display the **Audio**, **Disc Menu**, and **Subtitle** settings in during disc playback. The available options are English, French, Spanish, Italian or German.

The selected language will be heard or seen.

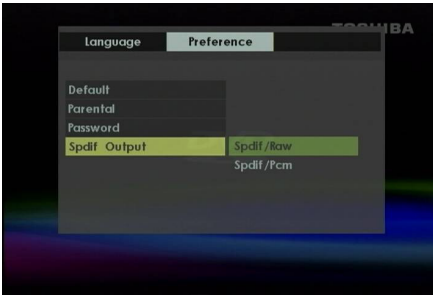

(Sample Image) Playback settings

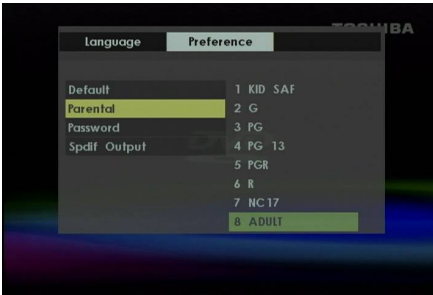

(Sample Image) Playback settings

Parental

A DVD is usually encoded with a rating level to indicate the recommended audience age. You have the option to select the content rating level allowed for playback in your LED TV/DVD combination.

Press the (▲/▼ arrow) buttons to select the allowable rating level, and then press the **OK** button. You will then need to type in the system password to save the setting.

- ❖ **Level 1–5:** Discs of varied non-adult ratings will be played back. The higher the number, the more severe the content is.
- ❖ **Level 6–8:** Discs of varied adult only ratings can be played back.

NOTE ❖ The Parental rating levels correspond to the US movie ratings.

Level 1 – Kids Safe	Level 5 – PG–R
Level 2 – G	Level 6 – R
Level 3 – PG	Level 7 – NC–17
Level 4 – PG–13	Level 8 – Adult

❖ Some discs may not have their rating level encoded on the disc though it's indicated on the disc jacket. Playback restriction will not apply to these discs so make sure to restrict access to it manually.

To temporarily cancel the parental restriction:

- 1 Load the restricted content DVD that you want to play.
- 2 Use the Channel Number buttons (0–9) to input the system password after the “Enter Password” message, and then press the **OK** button.

This suspension of the parental restriction setting applies until the disc is ejected.

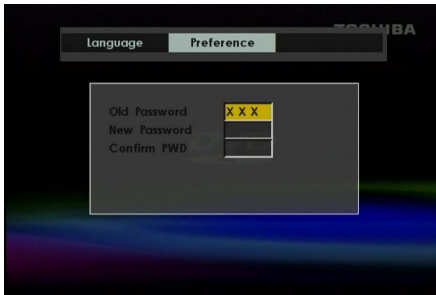

(Sample Image) Playback settings

Password

Select this option to change the access password for the parental control setting.

- 1 Press the (▲/▼ arrow) buttons to select Password, and then press the **OK** button.
- 2 Highlight **Change**, and then press the **OK** button.

- 3 Use the Channel Number buttons (0–9) to input the current password.
If the password has not been set yet, key in “0000.” This is the factory default password.
- 4 Use the Channel Number buttons (0–9) to input the new password.
You will be prompted to confirm the new password.
- 5 Use the Channel Number buttons (0–9) to input the new password again.
- 6 Note this new password for future reference.

If you forget the system password:

- 1 Make sure there is no disc in the disc slot.
- 2 Press and hold down the **VOLUME** (–) button on the TV control panel, and then press the number 4 button on the remote control for a few seconds.

The “Initializing” message appears on-screen to indicate that the password has been reset to its default factory setting “0000.” All DVD Setup related settings will also be reset to their default factory values.

Spdif Output (Digital Out)

Select the sound format of the digital output depending on the enabled signal connection.

- ❖ **Spdif/Raw:** Select this option to output the signal in its native format.
- ❖ **Spdif/Pcm:** Changes Dolby® Digital output to PCM. Select this option when using a two-channel digital stereo amplifier.

NOTE

MPEG audio will always be in PCM format regardless of the Digital Output setting.

Chapter 10

Troubleshooting

General troubleshooting

Before calling a service technician, review this chapter or visit the Toshiba technical support Web site at support.toshiba.com for possible causes/solutions for the problem you are experiencing.

Before you begin to troubleshoot any problem, first unplug the TV from the AC wall outlet, wait approximately one minute, and then plug the TV back into the AC wall outlet. If the problem still exists attempt to troubleshoot the problem.

Black box on-screen.

The closed caption feature is set to one of the Text modes (T1, T2, T3, or T4). Set the closed caption feature to Off, see “Using closed captions” on page 78.

TV stops responding to controls.

If the TV stops responding to the buttons on the remote control or TV control panel and you cannot turn off the TV, press and hold the **POWER** button on the TV control panel for several seconds to reset the TV. If the TV does not power off using this method, unplug the TV from the AC wall outlet and plug it back in.

If you cause a static discharge when touching the TV and the TV fails to function, simply unplug the TV from the AC outlet and plug it back in. The TV should return to normal operation.

Other problems.

If your TV's problem is not addressed in this Troubleshooting chapter or the recommended solution has not worked, use the Reset Factory Defaults procedure, see [“Reset Factory Defaults” on page 58](#).

TV will not turn on.

Ensure the power cord is plugged in properly, and then press the **POWER** button.

Replace the batteries in the remote control, see [“Installing batteries” on page 40](#).

Try the control panel buttons on the TV.

Picture problems**General picture problems.**

Check the antenna/cable connections, see [“Connecting Your TV” on page 24](#).

Press the **INPUT** button on the remote control or on the TV and select a valid video input source, see [“Selecting the video input source” on page 59](#). If no device is connected to an input on the TV, no picture appears when you select that particular input source. For device connection details, see [“Connecting Your TV” on page 24](#).

Antenna reception may be poor. Use a highly directional outdoor antenna (if applicable).

The station may be having broadcast difficulties. Try another channel.

Adjust the picture quality, see [“Using the advanced picture settings” on page 114](#).

Cannot view external signals or channel 3 or 4.

If you cannot view signals from external devices connected to VIDEO, ColorStream® HD1, ColorStream® HD, HDMI 1, HDMI 2, PC, or from channel 3 or 4, ensure that the Input Lock is set to **Off**, see [“Using the Locks menu” on page 86](#).

Noisy picture.

If you are watching an analog channel (off-air broadcast or cable TV), you can set the CableClear® feature to reduce visible interference in the TV picture, see [“CableClear® digital Noise Reduction” on page 116](#).

Video Input Selection problems.

If the Input Selection window does not appear when you press INPUT on the remote control or TV, press INPUT a second time. This will cause a change to the next video input source and display the Input Selection window.

Poor display color or no color.

The station may be having broadcast difficulties. Try another channel.

Adjust the Tint and/or Color, see. [“Adjusting the picture quality” on page 77](#)

Poor composite picture.

If the TV is connected to an external A/V device (e.g. DVD player, video game system, set-top box, etc.) try using a ColorStream® or HDMI® video connection instead.

Picture and sound are out of sync.

As with all products that contain a digital display, this may occur in rare instances, when viewing certain content (e.g. television broadcasts, video games, DVDs). The cause may include, without limitation, video processing within the TV, video processing in an attached gaming system, and video processing or different compression rates used by broadcasters in their programming.

Try the following:

- ❖ If the TV is connected to an A/V receiver that has a programmable audio delay feature, use this feature to help synchronize the sound to the picture.
- ❖ If the problem occurs only on certain TV channels, inform your local broadcast, cable, or satellite provider.
- ❖ Digital audio settings may not be correct. Check the connections, see [“Connecting a digital audio system” on page 35](#).
- ❖ Turn off and unplug the TV from the AC wall outlet for a few seconds and plug it back in.

Sound problems

Check the antenna/cable connections, see [“Connecting a VCR, antenna, or cable TV” on page 27](#).

The station may be having broadcast difficulties. Try another channel.

The sound may be muted. Press the **VOL (+)** button.

If you hear no sound, try setting the MTS feature to Stereo mode, see [“Using the MTS button” on page 83](#).

If you are not receiving a second audio program from a known SAP source, make sure the MTS feature is set to SAP mode, see [“Selecting stereo/SAP broadcasts” on page 82](#).

If you hear audio that seems incorrect for the program you are watching (such as music or a foreign language), the SAP mode may be on. Set the MTS feature to Stereo mode, see [“Selecting stereo/SAP broadcasts” on page 82](#).

If you connect a computer using either the PC IN terminal or an HDMI® terminal, make sure that the audio setting is properly set, see [“Setting the HDMI® audio mode” on page 55](#)

Remote control problems

Remove all obstructions between the remote control and the TV.

Replace the remote control’s batteries, see [“Installing batteries” on page 40](#).

Your TV’s remote control may not operate certain features on your external device. Refer to the User’s Guide for your other device to determine its available features. If your TV remote control does not operate a specific feature on another device, use the remote control that came with the device, see [“Learning about the remote control” on page 42](#).

If the TV still does not act as expected, perform the Reset Factory Defaults procedure, see [“Reset Factory Defaults” on page 58](#).

Channel tuning problems

Ensure that the remote control is set to the correct device mode, see [“Learning about the remote control” on page 42](#).

The Auto Tuning feature may have erased the channel from memory. Add the channel to the channel memory, see [“Storing channels in memory \(optional\)” on page 52](#).

The Lock feature may have blocked the channel. Unblock the channel, see [“Locking channels” on page 94](#).

If you cannot tune digital channels, check the antenna configuration. If the problem persists, clear all channels from the channel list and reprogram channels into the memory, see [“Storing channels in memory \(optional\)” on page 52](#). For additional information, see [“TV stops responding to controls.” on page 147](#). If the problem persists, use the Reset Factory Defaults procedure, see [“Reset Factory Defaults” on page 58](#).

Closed caption problems

If the program or video you have selected is not closed captioned, no captions appear on the screen.

If text is not available, a black rectangle may appear. If this happens, turn off the closed caption feature, see [“Using closed captions” on page 78](#).

A closed caption signal may not display correctly under the following circumstances:

- ❖ The recording is dubbed
- ❖ The signal reception is weak
- ❖ The signal reception is non-standard

For additional information, see [“Using closed captions” on page 78](#).

Rating blocking (V-Chip) problems

Forgotten PIN code.

When the PIN code screen appears, press the **INFO** button 4 times within approximately 5 seconds. The old PIN code is cleared, see [“Forgotten PIN code” on page 87](#).

The V-Chip feature is available for U.S. V-Chip systems only, see [“Using parental controls \(for USA region\)” on page 88](#).

No HDMI® CEC operation

The HDMI® CEC feature is available for Toshiba HDMI® CEC compatible devices.

Ensure that HDMI® cables with the (**HDMI**) Logo are used.

When the connected HDMI® CEC device does not work correctly after you have changed device’s settings, turn off your TV and unplug the power cord, then plug it in and turn on again.

If several devices are connected, the HDMI® CEC feature may not operate properly.

Read the instruction manual provided with the connected HDMI® CEC device.

HDMI® problems

HDMI® cables.

Ensure that HDMI® cables with the (**HDMI**) Logo are used, see [“Connecting an HDMI® or DVI device to the HDMI® input” on page 31](#).

Legacy HDMI® sources.

Some legacy HDMI® sources may not work properly with the latest HDMI® TV products, due to new standard adoption.

Media Player problems

Incorrect functionality may occur when using a USB HUB connection.

Photo files that were processed and edited using the computer's application software may not be viewable.

The TV may select one format automatically and play it when contents that support two or more formats are played.

Confirm that the contents of the USB storage device are in formats that are supported by this TV, see [“Using the Media Player” on page 99](#).

Disc playback problems**Playback does not start.**

No disc is loaded.

The disc may be dirty. Clean the disc.

The disc format is not supported, see [“Disc playback” on page 119](#).

No picture.

The TV is not in DVD mode.

No sound.

The TV is in the special playback mode, see [“Disc playback” on page 119](#).

If an external speaker is connected, check its volume control.

Picture distortion during fast reverse/forward playback.

The picture will be distorted occasionally. This is normal.

Playback features failure.

The playback features such as stopping, searching, slow motion play, repeat play or programmed play, etc. are not applicable to all discs.

Playback does not start when the title is selected.

The disc may not be compliant with the “Parental” setting, see [“Customizing disc playback” on page 141](#).

The audio sound track and/or subtitle language cannot be changed.

The disc has no multi-language option encoded on it, see “[Sound track language/Audio channel/Subtitle](#)” on page 131.

No subtitle.

The disc has no subtitle encoded on it.

Subtitles are disabled. Press the **SUB TITLE** button, see “[Viewing subtitles \(DVD\)](#)” on page 131.

Scene angle cannot be changed.

The disc has no multi-angle scenes, see “[Sound track language/Audio channel/Subtitle](#)” on page 131. An “**X**” appears on the screen.

The function is not applicable to the disc or to the current mode.

light indicator

The Power light on the front of the TV indicates the TV’s status, as described below.

Power indicator

The Power indicator glows green when the TV power is On.

If the problem persists after trying the solutions

Contact Toshiba at:

Toshiba’s Support Web site: support.toshiba.com.

For technical support, call the Toshiba Customer Support Center:

Within the United States, at 800-631-3811

Outside the United States, at 949-583-3050

Appendix A

Specifications

NOTE

- ❖ These models comply with the specifications listed below.
 - ❖ Designs and specifications are subject to change without notice.
 - ❖ These models may not be compatible with features and/or specifications that may be added in the future.
-

Television system

NTSC standard	
ATSC standard	8VSB
Digital Cable	64 QAM, 256 QAM; in-the-clear, unencrypted

Channel coverage

VHF	2 through 13
UHF	14 through 69
Cable TV	Mid band (A-8 through A-1, A through I)
	Super band (J through W)
	Hyper band (AA through ZZ, AAA, BBB)
	Ultra band (65 through 94, 100 through 135)

Power source

120 V AC, 60 Hz

Power maximum current

24V4210U	0.65 A
24V4260U	0.65 A

Power consumption

24V4210U	0.65 A (maximum current) 0.2W (Standby mode)
24V4260U	0.65 A (maximum current) 0.2W (Standby mode)

Audio power

24V4210U	5W + 5W
24V4260U	5W + 5W

Speaker type

24V4210U	Two 3 5/8 x 1 x 7/8 inches (91 x 25 x 23mm)
24V4260U	Two 3 5/8 x 1 x 7/8 inches (91 x 25 x 23mm)

Video/audio terminals

Video/audio input

Video	1 V (p-p), 75 ohm, negative sync.
Audio	200 mV(rms) (-20dBFS, 47K ohm or greater)

ColorStream[®] (component video) HD input

Video	Y: 1V(p-p), 75 ohm, negative sync.
	Y: 1V(p-p), 75 ohm, negative sync.
	PB: 0.7 V(p-p), 75 ohm
	Suggested formats: 1080i, 720p, 480p, 480i
Audio	200 mV(rms) (-20dBFS, 47K ohm or greater)

HDMI® input

HDMI® compliant	
HDCP compliant	
HDMI® Audio	2-channel Linear-PCM; 32/44.1/48 kHz sampling frequency; 16/ 20/24 bits per sample

Digital audio output

Optical type

PC input

15-Pin D-sub Analog RGB

DVD/CD player

Signal system	NTSC
Supported disc size	12 cm
Pickup mechanism	1-lens, 2-beams

Dimensions

24V4210U	Width	22.94" (583.1mm)
	Height	16.17" (410.9mm)
	Depth	9.18" (233.2mm)
24V4260U	Width	22.94" (583.1mm)
	Height	16.17" (410.9mm)
	Depth	9.18" (233.2mm)

Mass (weight)

24V4210U	13.2 lbs (6.0 kg)
24V4260U	13.2 lbs (6.0 kg)

Operating conditions

Temperature	32 - 95° F (0 - 35° C)
Humidity	20 - 80% (no moisture condensation)

Supplied accessories

- ❖ Remote control with two size “AAA” batteries
- ❖ Resource Guide
- ❖ Quick Start Guide
- ❖ Pedestal stand
- ❖ Warranty

Acceptable signal formats for PC IN, HDMI®

PC IN signal formats

NOTE Depending on the connected PC, the following status may occur; incorrect display, false format detection, picture position failure, blur, or judder. But this is not a malfunction of your TV.

<i>Format</i>	<i>Resolution</i>	<i>V. Frequency</i>	<i>H. Frequency</i>	<i>Pixel Clock Frequency</i>
VGA	640 x 480	59.940/60 Hz	31.469 kHz	25.175 MHz
SVGA	800 x 600	60.317 Hz	37.879 kHz	40.000 MHz
XGA	1024 x 768	60.004 Hz	48.363 kHz	65.000 MHz
WXGA	1280 x 768	59.870 Hz	47.776 kHz	79.500 MHz
	1360 x 768	60.015 Hz	47.712 kHz	85.500 MHz
SXGA	1280 x 1024	60.020 Hz	63.981 kHz	108.000 MHz

HDMI® signal formats

<i>Format</i>	<i>Resolution</i>	<i>V. Frequency</i>	<i>H. Frequency</i>	<i>Pixel Clock Frequency</i>
VGA	640 x 480	59.940 Hz	31.469 kHz	25.175 MHz
SVGA	800 x 600	60.317 Hz	37.879 kHz	40.000 MHz
XGA	1024 x 768	60.004 Hz	48.363 kHz	65.000 MHz
WXGA	1280 x 768	59.870 Hz	47.776 kHz	79.500 MHz
	1360 x 768	60.015 Hz	47.712 kHz	85.500 MHz
SXGA	1280 x 1024	60.020 Hz	63.981 kHz	108.000 MHz

Acceptable signal formats for PC IN, HDMI®

<i>Format</i>	<i>Resolution</i>	<i>V. Frequency</i>	<i>H. Frequency</i>	<i>Pixel Clock Frequency</i>
480i	720 x 480i	59.940 Hz	15.734 kHz	27.000 MHz
480p	720 x 480p	59.940 Hz	31.469 kHz	27.000 MHz
720p	1280 x 720p	60.000 Hz	45.000 kHz	74.250 MHz
1080i	1920 x 1080i	60.000 Hz	33.750 kHz	74.250 MHz
1080p	1920 x 1080p	24.000 Hz	27.000 kHz	74.250 MHz
		60.000 Hz	67.500 kHz	148.500 MHz

NOTE

- ❖ Some illustrations in this User's Guide are for explanation purposes and may differ from the actual unit.
- ❖ Designs and specifications are subject to change without notice.
- ❖ These models may not be compatible with features and/or specifications that may be added in the future.

Appendix B

License Agreement

License Information on the software used in the TOSHIBA Digital TV

The software pre-installed in the TOSHIBA Digital Televisions consists of multiple, independent software components. Each software component is copyrighted by TOSHIBA or a third party.

The TOSHIBA Digital Televisions uses software components that are distributed as freeware under a third-party end-user license agreement or copyright notice (hereinafter referred to as a "EULA"). Some EULAs require that the source code of the applicable component be disclosed as the condition for distributing the software component in executable format.

In addition, some of the software components which are used in Toshiba Digital Televisions include the software that are made or developed originally by TOSHIBA. These software and accompanied documents are copyrighted by TOSHIBA, and protected by Copyright Act, an international treaty's articles and other governing laws. The software components which are made or developed originally by TOSHIBA and not subject to EULAs are not a target of source code offering.

The Toshiba warranty provided in respect of the Digital TV is the only warranty provided and no additional warranties are provided in respect of the software components subject to EULAs.

Some of the software components distributed under EULAs are made available for use by the user on the premise that they are not copyrighted or warranted by TOSHIBA or any third party. These software components are licensed to the user free of charge and therefore not covered by any warranty within the scope of the applicable laws. These software components are provided in "as is" condition without any warranty, whether express or implied. "Warranty" here includes, but not limited to, an implied warranty for marketability

or fitness for specific uses. All risks associated with the quality or performance of these software components are assumed by the user. TOSHIBA shall not be liable whatsoever for any cost of repair or correction or other incidental expense incurred in connection with a defect found in any of these software components. Unless specified under the applicable laws or in a written agreement, a party who changes or redistributes the software with consent from the copyright holders or based on the aforementioned licenses shall not be held liable whatsoever for any loss arising from the use of or inability to use such software components. The same applies even when the copyright holders or relevant third parties have been informed of the possibility of such loss. "Loss" here includes normal, special, incidental and indirect loss (including, but not limited to, the loss of data or its accuracy; loss incurred by the user or any third party; and interface incompatibility with other software). Please read each EULA for details on the use conditions and items that must be observed regarding these software components.

The table below lists the software components pre-installed in the TOSHIBA Digital Televisions, which are subject to EULAs. The user should read the applicable EULAs carefully before using these software components. The EULAs are exhibited in their original text (English) as exactly written by the respective parties other than TOSHIBA.

For at least three (3) years from the date of distribution of the this product, Toshiba will give to anyone who contacts Toshiba Consumer Solutions at (800) 631-3811, for a charge of no more than our cost of physically performing source code distribution, a complete machine-readable copy of the complete corresponding GPL and LGPL source code for the version of the GPL and LGPL code that we distributed to you in this product.

Pre-Installed Software - EULA

jpeglib.h - Exhibit A

FreeType 2.2.0 - Exhibit B

scalfact.c - Exhibit C

Exhibit A

The authors make NO WARRANTY or representation, either express or implied, with respect to this software, its quality, accuracy, merchantability, or fitness for a particular purpose. This software is provided "AS IS", and you, its user, assume the entire risk as to its quality and accuracy.

This software is copyright (C) 1991-2011, Thomas G. Lane, Guido Vollbeding.

All Rights Reserved except as specified below.

Permission is hereby granted to use, copy, modify, and distribute this software (or portions thereof) for any purpose, without fee, subject to these conditions:

- (1) If any part of the source code for this software is distributed, then this README file must be included, with this copyright and no-warranty notice unaltered; and any additions, deletions, or changes to the original files must be clearly indicated in accompanying documentation.
- (2) If only executable code is distributed, then the accompanying documentation must state that "this software is based in part on the work of the Independent JPEG Group".

(3) Permission for use of this software is granted only if the user accepts full responsibility for any undesirable consequences; the authors accept NO LIABILITY for damages of any kind.

These conditions apply to any software derived from or based on the IJG code, not just to the unmodified library. If you use our work, you ought to acknowledge us.

Permission is NOT granted for the use of any IJG author's name or company name in advertising or publicity relating to this software or products derived from it. This software may be referred to only as "the Independent JPEG Group's software".

We specifically permit and encourage the use of this software as the basis of commercial products, provided that all warranty or liability claims are assumed by the product vendor. ansi2knr.c is included in this distribution by permission of L. Peter Deutsch, sole proprietor of its copyright holder, Aladdin Enterprises of Menlo Park, CA. ansi2knr.c is NOT covered by the above copyright and conditions, but instead by the usual distribution terms of the Free Software Foundation; principally, that you must include source code if you redistribute it. (See the file ansi2knr.c for full details.) However, since ansi2knr.c is not needed as part of any program generated from the IJG code, this does not limit you more than the foregoing paragraphs do.

The Unix configuration script "configure" was produced with GNU Autoconf. It is copyright by the Free Software Foundation but is freely distributable. The same holds for its supporting scripts (config.guess, config.sub, ltmain.sh). Another support script, install-sh, is copyright by X Consortium but is also freely distributable.

The IJG distribution formerly included code to read and write GIF files. To avoid entanglement with the Unisys LZW patent, GIF reading support has been removed altogether, and the GIF writer has been simplified to produce "uncompressed GIFs." This technique does not use the LZW algorithm; the resulting GIF files are larger than usual, but are readable by all standard GIF decoders.

We are required to state that

"The Graphics Interchange Format(c) is the Copyright property of CompuServe Incorporated. GIF(sm) is a Service Mark property of CompuServe Incorporated."

Exhibit B

The FreeType Project LICENSE

2002-Apr-11

Copyright 1996-2002 by

David Turner, Robert Wilhelm, and Werner Lemberg

Introduction

The FreeType Project is distributed in several archive packages; some of them may contain, in addition to the FreeType font engine, various tools and contributions which rely on, or relate to, the FreeType Project.

This license applies to all files found in such packages, and which do not fall under their own explicit license. The license affects thus the FreeType font engine, the test programs, documentation and makefiles, at the very least.

This license was inspired by the BSD, Artistic, and IJG (Independent JPEG Group) licenses, which all encourage inclusion and use of free software in commercial and freeware products alike. As a consequence, its main points are that:

- ❖ We don't promise that this software works. However, we will be interested in any kind of bug reports. (‘as is’ distribution)
- ❖ You can use this software for whatever you want, in parts or full form, without having to pay us. (‘royalty-free’ usage)
- ❖ You may not pretend that you wrote this software. If you use it, or only parts of it, in a program, you must acknowledge somewhere in your documentation that you have used the FreeType code. (‘credits’)

We specifically permit and encourage the inclusion of this software, with or without modifications, in commercial products. We disclaim all warranties covering The FreeType Project and assume no liability related to The FreeType Project.

Finally, many people asked us for a preferred form for a credit/disclaimer to use in compliance with this license. We thus encourage you to use the following text:

Portions of this software are copyright © 1996-2002 The FreeType
Project (www.freetype.org). All rights reserved.

Exhibit C

scalfact.c Scalefactors for layer I and II This program is free software; you can redistribute it and/or modify it under the terms of the GNU General Public License as published by the Free Software Foundation; either version 2 of the License, or (at your option) any later version. This program is distributed in the hope that it will be useful, but WITHOUT ANY WARRANTY; without even the implied warranty of MERCHANTABILITY or FITNESS FOR A PARTICULAR PURPOSE. See the GNU General Public License for more details. You should have received a copy of the GNU General Public License along with this program; if not, write to the Free Software Foundation, Inc., 675 Mass Ave, Cambridge, MA 02139, USA.

Index

A

- advanced picture settings
 - CableClear® digital Noise Reduction 116
 - Color temperature 115
 - Dynamic Contrast 114
 - Game Mode feature 117
 - MPEG Noise Reduction 117
 - Static Gamma 115
 - using 114
- audio
 - adjusting quality 83
 - Audyssey ABX™ 84
 - Dolby® Digital Dynamic Range Control 85
 - MTS button 83
 - muting sound 81
 - optical audio output format 85
 - stereo/SAP broadcasts 82
- Auto Aspect
 - using 74
- auto power down
 - set 107
- auto power off feature 113

- Auto Start function
 - Media Player 100

B

- blocking programs
 - Canada rating 92

C

- cables
 - 3.5mm to RCA Y-cable 26
 - analog RGB (15-pin) 26
 - coaxial (F-type) 24
 - component video (red/white/yellow) 25
 - HDMI® 25
 - optical audio 26
 - overview of cables 24
 - standard A/V (red/white/yellow) 25
- channel
 - switching between two channels 68
 - tuning channels 67
 - tuning to a specific channel 68
- Channel Browser
 - elements 65

- tuning channels 63
- Channel Return
 - switching between two channels 68
- channels
 - auto tuning 52
 - locking channels 94
 - skipping 54
 - specific channel 67
 - storing in memory 52
- cinema mode
 - selecting 75
- closed captions
 - CC selector 80
 - Digital CC settings 80
 - using 78
- computer
 - setting the audio 98
 - using with the TV 97
- connecting
 - a computer 37
 - audio system 35
 - cable TV 27
 - camcorder 28
 - computer to TV's PC IN 37
 - DVD player with ColorStream® 29
 - DVI device to HDMI® input 31
 - HDMI® device to HDMI® input 31
 - HDMI®-CEC 34
 - satellite receiver 30
 - TV's HDMI® 39
 - VCR and antenna 27

D

- digital audio selector
 - using 82
- Digital Signal Meter
 - viewing 57
- Disc
 - audio channel 131
 - DVD menu 130
 - playback information 132
 - scene angle 130
 - scene bookmark 126
 - sound track language 131
 - subtitle 131
 - title selection 130
 - VCD playback control 132
- disc
 - /A-B repeat mode (DVD/VCD/CD) 129
 - audio channel (VCD) 131
 - DVD menu 130
 - DVD title 130
 - enable repeat playback 128
 - enabling PBC function 132
 - enabling repeat playback 139
 - file browser 135
 - locating a scene 125
 - playback info (DVD/VCD) 132
 - playback options 143
 - playback sequence 140
 - playback setting 141
 - playback/A-B repeat 128
 - playing audio file 136
 - scene 124
 - scene angle DVD 130
 - scene bookmark (DVD/VCD) 127
 - sound track language (DVD) 131
 - viewing JPEG file 137
 - viewing scene bookmark 128
 - viewing slide show 138
 - viewing subtitles (DVD) 131
 - zoom 124
 - zoom DVD/VCD 124
- disc playback 119
 - customizing 141
 - DVD/VCD/CD 119
 - playback reminders 121
 - removing a disc 121
- disc playback navigation 122

- chapter or track 123
- fast reverse, fast forward 122
- frame by frame 123
- slow motion 123

E

Elements 65

F

- factory defaults
 - reset 58
- favorites browser 64
- features 18
- Freeze
 - feature 75

G

- GameTimer®
 - using 95

H

- HDMI® audio mode
 - setting 55
- HDMI®-CEC
 - additional functions 111
 - using 108
 - volume/mute controls 110
- History List
 - adding/clearing channels 67
 - adding/clearing inputs 67

I

- information
 - MP3/WMA/JPEG/Audio 133
- Initial setup 50
- initial setup
 - main menu layout 46
- input lock feature
 - using 94

L

- last mode memory feature 113
- Locks menu
 - setting pin code 86

M

- Media Player
 - open 100
 - photo files 101
 - playing music files 103
 - using 99
- menu
 - layout 47
 - navigation 48
 - setup 47

N

- no signal power down
 - set 108

O

- operation
 - MP3/WMA/JPEG/Audio CD 133
- overview
 - installation 19
 - setup 19
 - use 19

P

- panel lock feature
 - using 96
- parental controls
 - blocking programs/movies by rating (V-Chip) 88
 - using 88
- PC Audio
 - setting 98
- PC settings feature
 - using 97
- picture
 - adjusting 76
 - adjusting quality 77
- picture mode
 - selecting 76
- picture size
 - 4

- Dot by Dot 73
- Full 70
- Native 72
- Normal 73
- selecting 69
- TheaterWide 1 71
- TheaterWide 2 71
- TheaterWide 3 71
- pin code
 - changing 87
 - entering PIN code 86
 - forgotten 87
- playback modes
 - MP3/WMA/JPEG/Audio CD 139
- program ratings
 - displaying 92
 - unlocking programs 93
- Q**
- quick setup
 - ANT/CABLE IN 51
 - menu language 51
- R**
- rating system 91
 - downloading additional 89
- S**
- screen angle
 - adjusting 22
- scrolling
 - TheaterWide® picture 73
- specifications
 - acceptable signal formats 158
 - audio power 155
 - channel coverage 154
 - ColorStream® HD input 156
 - Digital audio output 157
 - dimensions 157
 - DVD/CD player 157
 - HDMI® input 157
 - HDMI® signal formats 158
 - mass (weight) 157
 - operating conditions 157
 - PC IN signal formats 158
 - PC input 157
 - power consumption 155
 - power maximum current 155
 - power source 155
 - speaker type 155
 - supplied accessories 158
 - TV system 154
 - video/audio terminals 155
- SurfLock™
 - switching between two channels 68
- system status
 - viewing 58
- T**
- time zone
 - setting 57
- timer
 - sleep timer 106
- troubleshooting 147
 - channel tuning problems 150
 - closed caption problems 151
 - contact Toshiba 153
 - disc playback problems 152
 - HDMI® 151
 - light indicator 153
 - media player problems 152
 - No HDMI®-CEC operation 151
 - picture problems 148
 - power indicator functions 153
 - Rating blocking problems 151
 - remote control problems 150
 - sound problems 149
- Tuning 63
- TV connections
 - front 20
 - side 20
- TV panel connections
 - back 22

TV panel controls

front 20

left side 20

side 20

TV remote

functionality 42

install batteries 40

TV remote control

using 40

TV status information

show 112

V

video input source

selecting 59

video input sources

labeling 61