

TAP 3/8" - 16 UNC
 1.12" DEEP MAX.
 CLASS 3 R.H.

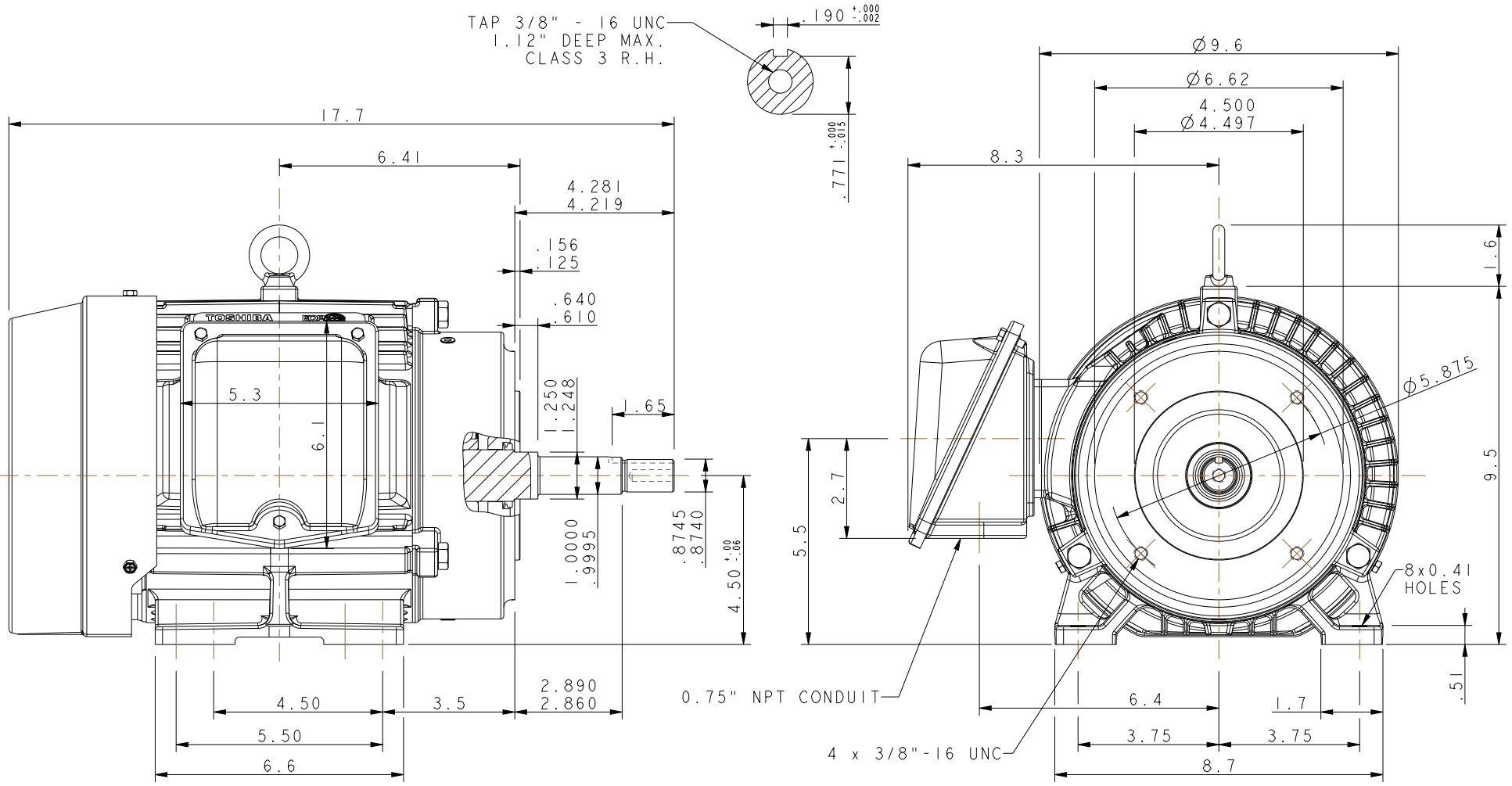

UNITS: INCHES
 ROTATION FROM NDE

CCW CW

NOTES:
 1. MAIN CONDUIT BOX MAY BE ROTATED IN 90° INCREMENTS
 2. STANDARD PRODUCT USES BI-DIRECTIONAL FAN. OPPOSITE ROTATION AVAILABLE ONLY BY CONNECTION CHANGE.
 3. KEY DIMENSIONS EQUAL 0.188"x 0.188"x 1.65"(MOTOR SUPPLIED WITH KEY)

TOSHIBA RESERVES THE RIGHT TO MAKE CHANGES OF TECHNICAL IMPROVEMENT AND THE DATA MAY CHANGE WITHOUT NOTICE PRELIMINARY
 DO NOT USE FOR CONSTRUCTION, INSTALLATION, OR APPLICATION PURPOSES UNLESS THE DRAWING IS MARKED AS CERTIFIED CERTIFIED

TOSHIBA SEVERE DUTY
www.toshiba.com/tic **EQP Global SD**
TOSHIBA INTERNATIONAL CORPORATION

**TOTALLY ENCLOSED FAN COOLED
 HORIZONTAL FOOT MOUNTED
 3 PHASE INDUCTION MOTOR
 182JM/184JM F1 ASSEMBLY**

DRAWING #: MDSLVI08-02
REV. DATE: 10/14/22 **REV. #:** 5 **PER.:** M. O'DOWD
REV. DESCRIP.: UPDATED TOLERANCES

TYPICAL MOTOR PERFORMANCE DATA

Model: 0032SDJC41M-P

HP	kW	Pole	FL RPM	Frame	Voltage	Hz	Phase	FL Amps
3	2.2	2	3500	182JM		60	3	6.0/3.0
Enclosure	IP	Ins. Class	S.F.	Duty	NEMA Nom. Eff.	NEMA Design	kVA Code	Ambient (°C)
TEFC	55	F	1.15	CONT	86.5	B		40 C

Load	HP	kW	Amperes	Efficiency (%)	Power Factor (%)
Full Load	3.00	2.2	3.0	86.7	88.7
¾ Load	2.25	1.7	2.2	86.6	85.6
½ Load	1.50	1.1	1.7	84.6	78.1
¼ Load	0.75	0.6	1.1	77.3	63.7
No Load			1.0		
Locked Rotor			24		50.4

Torque				Rotor wk ² Inertia (lb-ft ²)
Full Load (lb-ft)	Locked Rotor (% FLT)	Pull Up (% FLT)	Break Down (% FLT)	
4.50	185	165	350	0.13

Safe Stall Time(s)		Sound Pressure dB(A) @ 1M	Bearings*		Approx. Motor Weight (lbs)
Cold	Hot		DE	NDE	
35	15	-	6306ZZC3	6306ZZC3	80

*Bearings are the only recommended spare part(s).

Motor Options:
Product Family:EQP Global JM
Mounting:Footed,Shaft:JM Shaft

Customer	
Customer PO	
Sales Order	
Project #	

Tag:

All characteristics are average expected values.

TOSHIBA INTERNATIONAL CORPORATION · HOUSTON, TEXAS U.S.A.

Engineering	aacosta	Doc. Written By	D. Suarez	Doc.# / Rev	MPCF-1119 / 0
Engr. Date	4/19/2012	Doc. Approved By	M. Campbell	Doc. Issued	6/8/2011

SPEED TORQUE/CURRENT CURVE

Model: 0032SDJC41M-P

HP	kW	Pole	FL RPM	Frame	Voltage	Hz	Phase	FL Amps
3	2.2	2	3500	182JM		60	3	6.0/3.0
Enclosure	IP	Ins. Class	S.F.	Duty	NEMA Nom. Eff.	NEMA Design	kVA Code	Ambient (°C)
TEFC	55	F	1.15	CONT	86.5	B		40 C
Locked Rotor Amps	Rotor wk ² Inertia (lb-ft ²)	Torque						
		Full Load (lb-ft)	Locked Rotor (%)	Pull Up (%)	Break Down (%)			
24	0.13	4.50	185	165	350			

Design Values

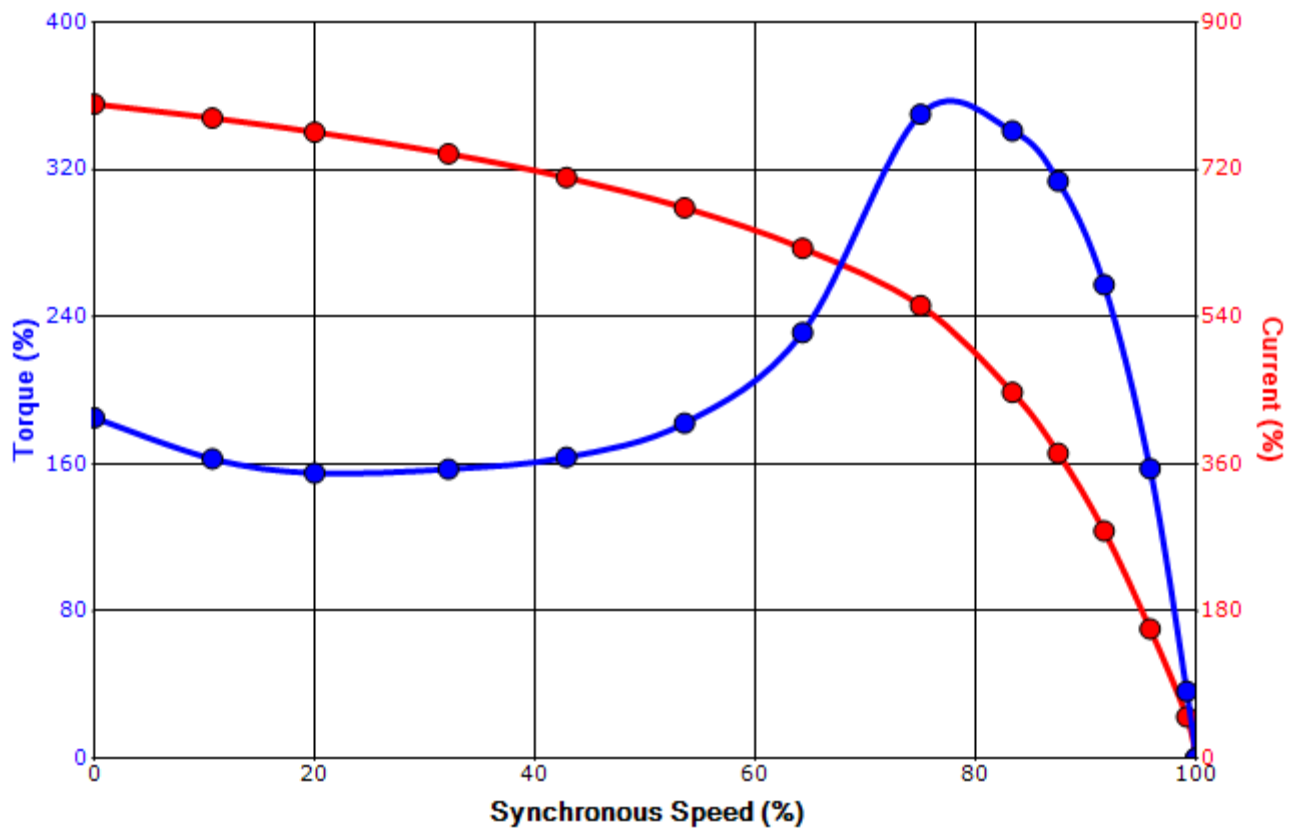

Customer		wk ² Load Inertia (lb-ft ²)	-
Customer PO		Load Type	-
Sales Order		Voltage (%)	100
Project #		Accel. Time	-

Tag:

All characteristics are average expected values.

TOSHIBA INTERNATIONAL CORPORATION · HOUSTON, TEXAS U.S.A.

Engineering	aacosta	Doc. Written By	D. Suarez	Doc.# / Rev	MPCF-1121 / 0
Engr. Date	4/19/2012	Doc. Approved By	M. Campbell	Doc. Issued	6/8/2011

Motor Connection Diagram

3 Leads - Wye Connection

Single Voltage



Switch L1 and L2 to reverse rotation

Each lead may consist of more than one cable.
If multiple cables represent a single lead, each one of them will be labeled with the appropriate lead number.