

TAP 3/8" - 16 UNC  
1.12" DEEP MAX.  
CLASS 3 R.H.

.190 <sup>+0.000</sup>/<sub>-.002</sub>

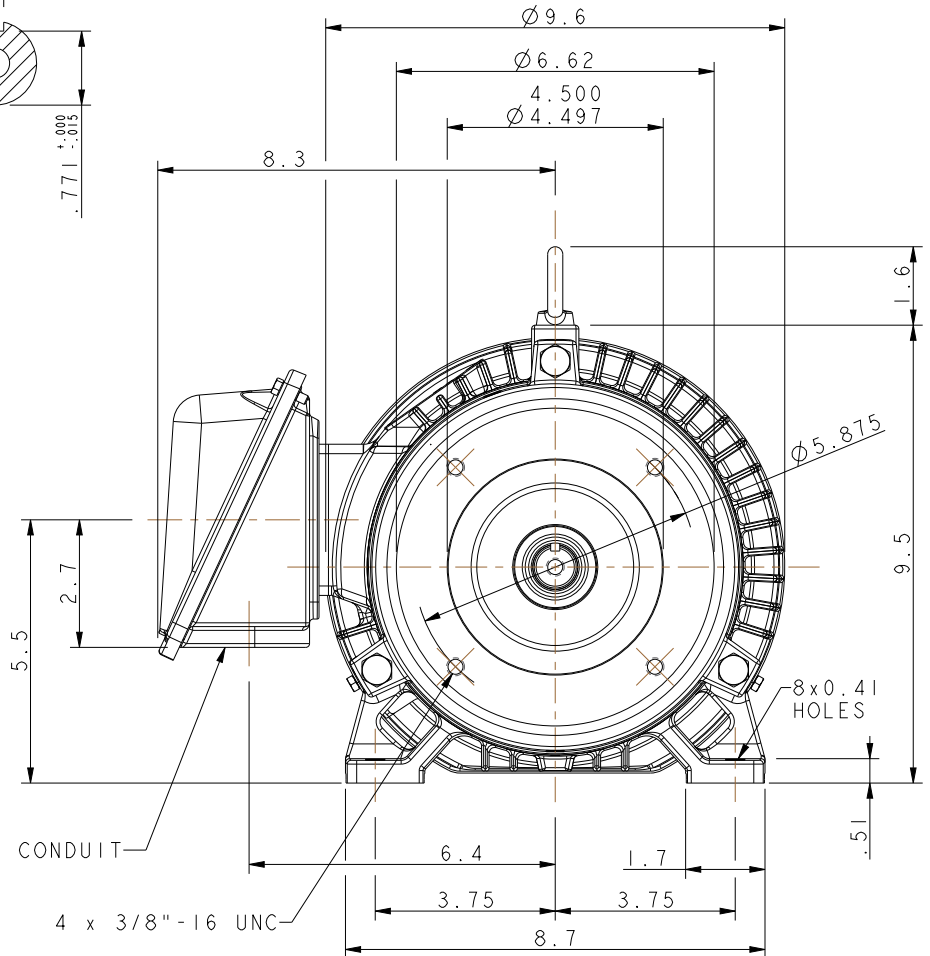
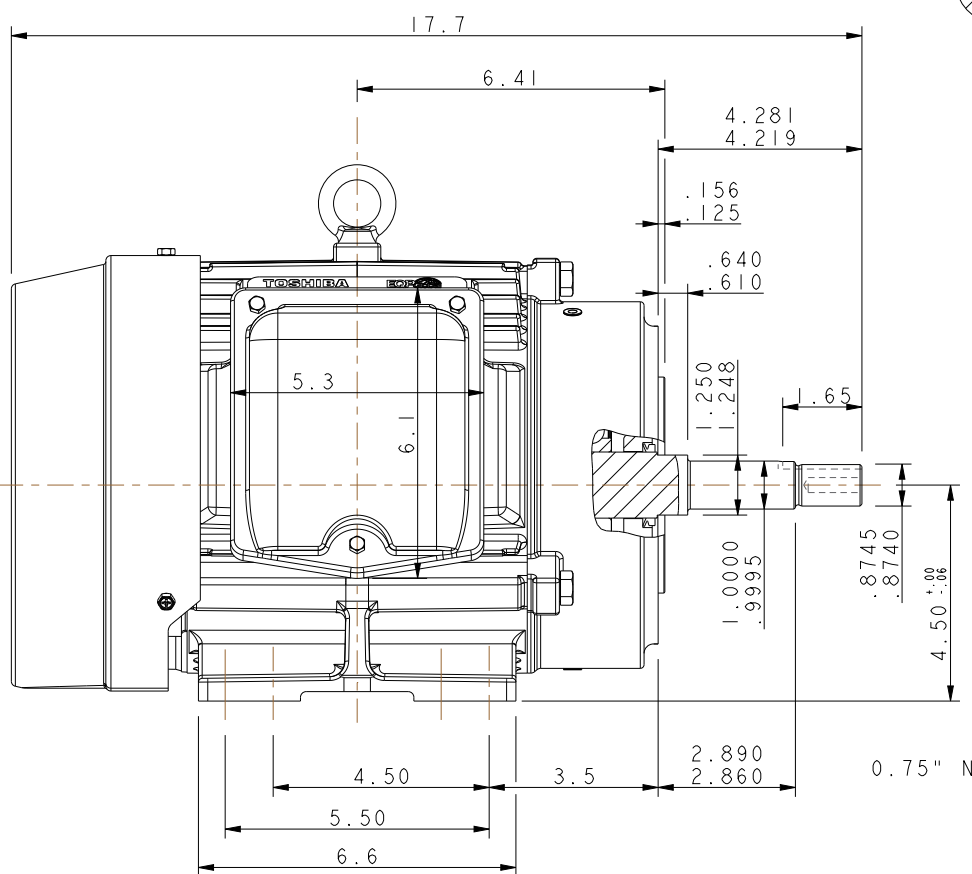
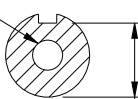

UNITS: INCHES

ROTATION FROM NDE

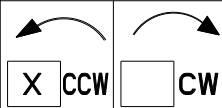

NOTES:

1. MAIN CONDUIT BOX MAY BE ROTATED IN 90° INCREMENTS
2. STANDARD PRODUCT USES BI-DIRECTIONAL FAN. OPPOSITE ROTATION AVAILABLE ONLY BY CONNECTION CHANGE.
3. KEY DIMENSIONS EQUAL 0.188"x 0.188"x 1.65"(MOTOR SUPPLIED WITH KEY)

TOSHIBA RESERVES THE RIGHT TO MAKE CHANGES OF TECHNICAL IMPROVEMENT AND THE DATA MAY CHANGE WITHOUT NOTICE  PRELIMINARY

DO NOT USE FOR CONSTRUCTION, INSTALLATION, OR APPLICATION PURPOSES UNLESS THE DRAWING IS MARKED AS CERTIFIED  CERTIFIED

**TOSHIBA** SEVERE DUTY  
www.toshiba.com/tic **EQP Global SD**  
**TOSHIBA INTERNATIONAL CORPORATION**

**TOTALLY ENCLOSED FAN COOLED  
HORIZONTAL FOOT MOUNTED  
3 PHASE INDUCTION MOTOR  
182JM/184JM F1 ASSEMBLY**

**DRAWING #:** MDSLVI08-02  
**REV. DATE:** 10/14/22 **REV. #:** 5 **PER.:** M. O'DOWD  
**REV. DESCRIP.:** UPDATED TOLERANCES

**TYPICAL MOTOR PERFORMANCE DATA**

Model: 0034SDJC41M-P

HP	kW	Pole	FL RPM	Frame	Voltage	Hz	Phase	FL Amps
3	2.2	4	1760	182JM	575	60	3	3.1
Enclosure	IP	Ins. Class	S.F.	Duty	NEMA Nom. Eff.	NEMA Design	kVA Code	Ambient (°C)
TEFC	55	F	1.15	CONT	89.5	B		40 C

Load	HP	kW	Amperes	Efficiency (%)	Power Factor (%)
Full Load	3.00	2.2	3.1	90.2	80.4
¾ Load	2.25	1.7	2.4	89.5	76.2
½ Load	1.50	1.1	1.9	86.9	67.5
¼ Load	0.75	0.6	1.3	78.6	52.9
No Load			1.3		6.6
Locked Rotor			25		47.1

Torque				Rotor wk <sup>2</sup>
Full Load (lb-ft)	Locked Rotor (% FLT)	Pull Up (% FLT)	Break Down (% FLT)	Inertia (lb-ft <sup>2</sup> )
8.96	280	215	355	0.43

Safe Stall Time(s)		Sound Pressure dB(A) @ 1M	Bearings*		Approx. Motor Weight (lbs)
Cold	Hot		DE	NDE	
35	15	-	6306ZZC3	6306ZZC3	92

\*Bearings are the only recommended spare part(s).

**Motor Options:**  
Product Family:EQP Global JM  
Mounting:Footed,Shaft:JM Shaft

Customer	
Customer PO	
Sales Order	
Project #	

Tag:

All characteristics are average expected values.

**TOSHIBA INTERNATIONAL CORPORATION · HOUSTON, TEXAS U.S.A.**

Engineering	bmmamen	Doc. Written By	D. Suarez	Doc.# / Rev	MPCF-1119 / 0
Engr. Date	7/24/2024	Doc. Approved By	M. Campbell	Doc. Issued	6/8/2011

**SPEED TORQUE/CURRENT CURVE**

Model: 0034SDJC41M-P

HP	kW	Pole	FL RPM	Frame	Voltage	Hz	Phase	FL Amps
3	2.2	4	1760	182JM	575	60	3	3.1
Enclosure	IP	Ins. Class	S.F.	Duty	NEMA Nom. Eff.	NEMA Design	kVA Code	Ambient (°C)
TEFC	55	F	1.15	CONT	89.5	B		40 C
Locked Rotor Amps	Rotor wk <sup>2</sup> Inertia (lb-ft <sup>2</sup> )	Torque						
		Full Load (lb-ft)	Locked Rotor (%)	Pull Up (%)	Break Down (%)			
25	0.43	8.96	280	215	355			

**Design Values**

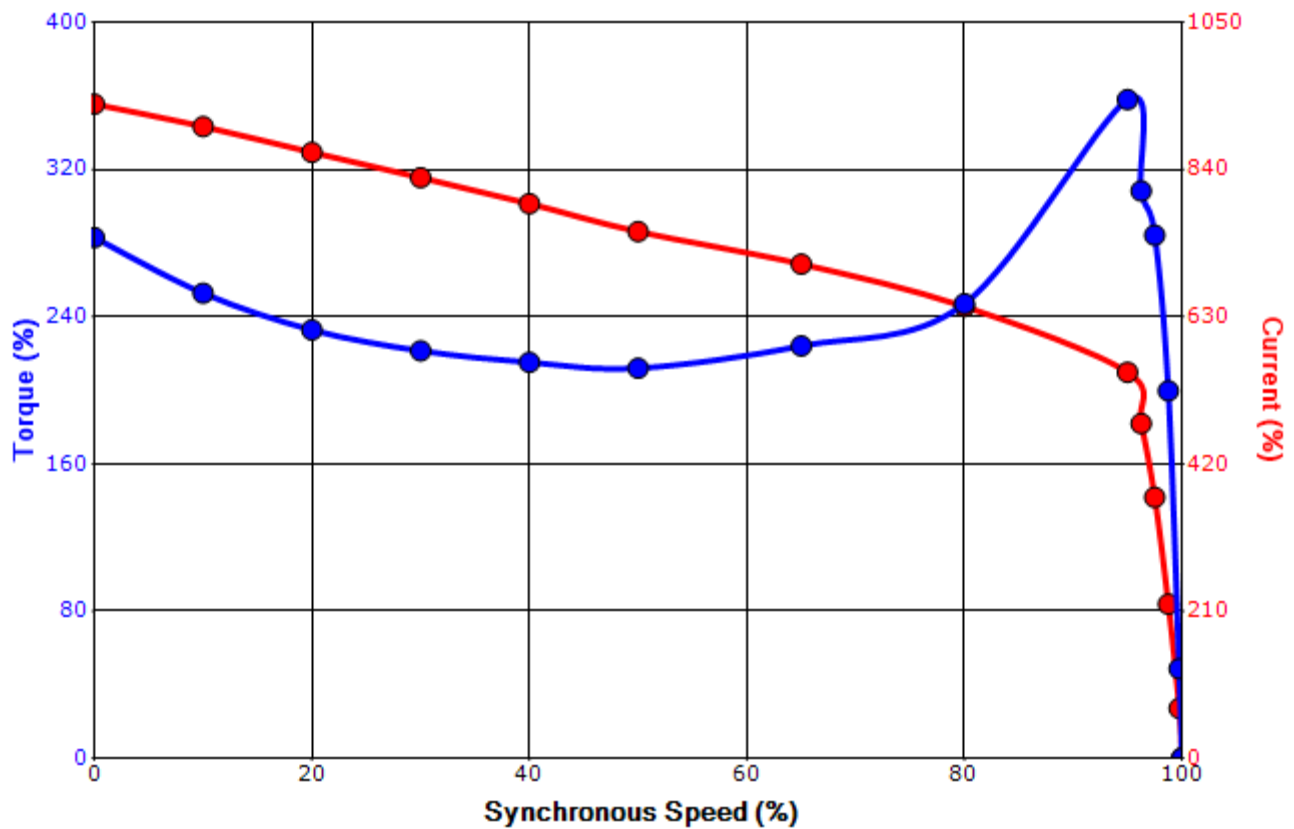

Customer		wk <sup>2</sup> Load Inertia (lb-ft <sup>2</sup> )	-
Customer PO		Load Type	-
Sales Order		Voltage (%)	100
Project #		Accel. Time	-

Tag:

All characteristics are average expected values.

**TOSHIBA INTERNATIONAL CORPORATION · HOUSTON, TEXAS U.S.A.**

Engineering	bmmamen	Doc. Written By	D. Suarez	Doc.# / Rev	MPCF-1121 / 0
Engr. Date	7/24/2024	Doc. Approved By	M. Campbell	Doc. Issued	6/8/2011

# Motor Connection Diagram

## 3 Leads - Wye Connection

### Single Voltage



Switch L1 and L2 to reverse rotation

Each lead may consist of more than one cable.  
If multiple cables represent a single lead, each one of them will be labeled with the appropriate lead number.