

INDEX	SAS013488
REV. LEVEL	01
SHEET	1 OF 1

TOSHIBA/HOUSTON

OPEN DRIP-PROOF
HORIZONTAL FOOT-MOUNTED

Fr. 284T

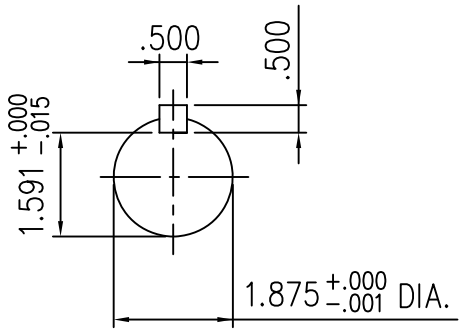
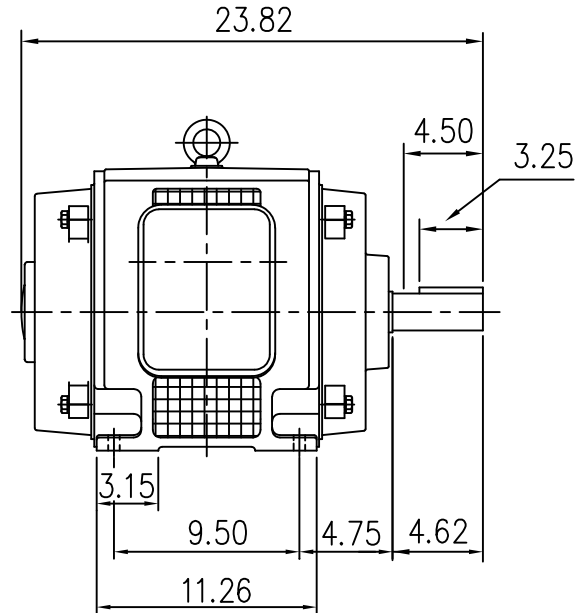
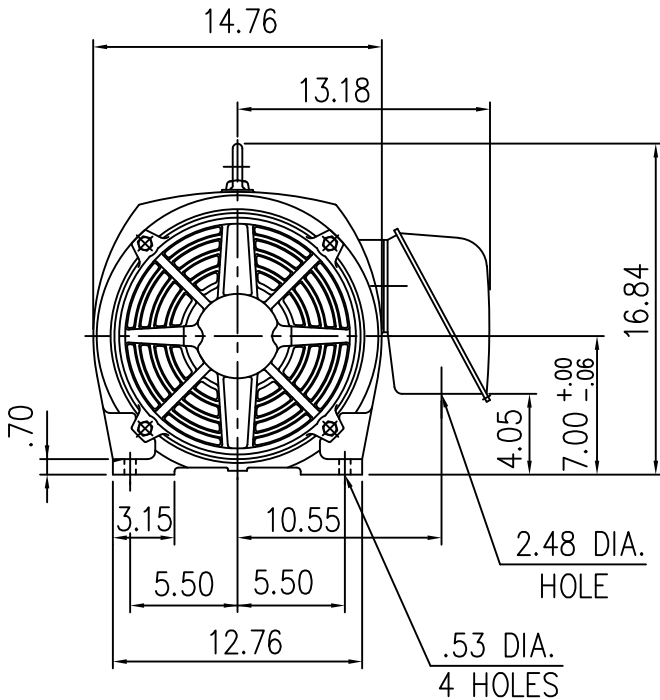

- (1) DIMENSIONS ARE IN INCHES
- (2) DRIVE END BEARING 6312C3
OPPOSITE DRIVE END BEARING 6312C3
- (3) LEAD WIRE: 8 FEET LENGTH

ALL DATA SUBJECT TO CHANGE WITHOUT NOTICE.
FOR CONSTRUCTION USE ONLY CERTIFIED DATA.

CERTIFIED DATA

CUSTOMER: _____ P.O. NO.: _____ TAG NO.: _____
 MOTOR MODEL NO.: _____ TOSHIBA FILE NO.: _____
 HP: _____ RPM (SYN.): _____ VOLTAGE: _____ Hz: _____
 FRAME SIZE: _____ LOG NO.: _____ LOG REV. LEVEL: _____
 REMARKS: _____

PER: _____ ISSUE DATE: _____ SUPERSEDES: _____

TYPICAL MOTOR PERFORMANCE DATA

Model: 0108DPKB31A-PY

HP	kW	Pole	FL RPM	Frame	Voltage	Hz	Phase	FL Amps
10	7.5	8	885	284T	460	60	3	15.1
Enclosure	IP	Ins. Class	S.F.	Duty	NEMA Nom. Eff.	NEMA Design	kVA Code	Ambient (°C)
ODP	22	H	1.15	CONT.	90.2	B	G	115

Load	HP	kW	Amperes	Efficiency (%)	Power Factor (%)
Full Load	10	7.5	15.1	90.2	69
¾ Load	7.5	5.63	12.4	89.6	63.3
½ Load	5	3.75	10.36	87.6	51.6
¼ Load	2.5	1.86	8.85	80.4	32.9
No Load			8		
Locked Rotor			75		

Torque				Rotor wk ² Inertia (lb-ft ²)
Full Load (lb-ft)	Locked Rotor (% FLT)	Pull Up (% FLT)	Break Down (% FLT)	
59.2	194	150	249	18.78

Safe Stall Time(s)		Sound Pressure dB(A) @ 1M	Bearings*		Approx. Motor Weight (lbs)
Cold	Hot		DE	NDE	
24	12	67	6312C3	6212C3	380

*Bearings are the only recommended spare part(s).

Motor Options:

Customer	
Customer PO	
Sales Order	
Project #	

Tag:

All characteristics are average expected values. The declared locked rotor current has a tolerance of 20%.

TOSHIBA INTERNATIONAL CORPORATION · HOUSTON, TEXAS U.S.A.

Engineering		Doc. Written By		Doc.# / Rev	
Engr. Date		Doc. Approved By		Doc. Issued	

TOSHIBA

Three Phase Motor Wiring Diagram
"Across the line" (Full Voltage) Starting

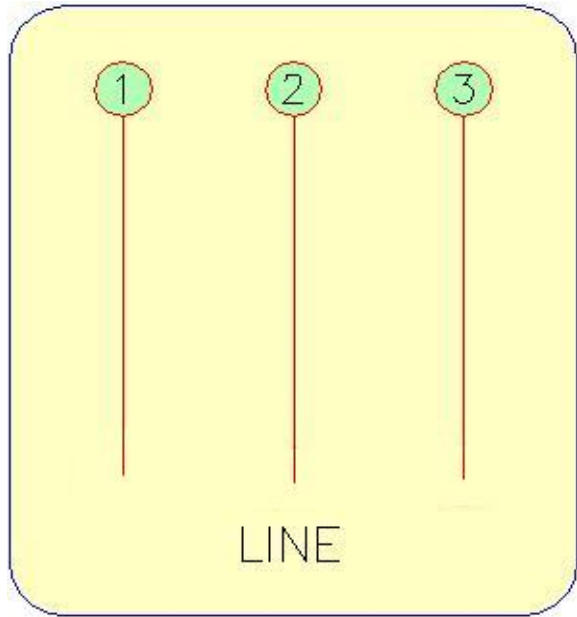

Customer Name:	
PO No.:	
Customer Tag:	
TIC File No.:	
Motor Model No.	

For Further Information Regarding Toshiba motor starting, maintenance or wiring,
Please refer to the "Toshiba - A Quality Product for World Energy" Installation and
Maintenance Manual, or contact the Toshiba Low Voltage Motor Marketing Department.
(800) 231-1412

Prepared By: D. Schoeck
Date: 10-Jan-2019

TOSHIBA

TOSHIBA INTERNATIONAL CORPORATION

INDUSTRIAL DIVISION

PO BOX 40906

HOUSTON TX 77240

(713) 466-0277

(800) 231-1412

FAX (713) 466-8773

SPARE PARTS (RECOMMENDED)

OTHER THAN THE GREASE USED FOR RE-GREASABLE BEARINGS, **TOSHIBA** ADVISES THAT THERE ARE NO "USE" PARTS. THE ONLY INSURANCE SPARES THAT **TOSHIBA** SUGGESTS FOR THESE SQUIRREL CAGE INDUCTION MOTORS ARE INDUSTRY STANDARD, AND COMMERCIALY AVAILABLE ANTI-FRICTION BEARINGS, AS NOTED BELOW.

MOTOR COMPONENTS (SUCH AS TERMINAL BOXES, FAN COVERS, MACHINED PARTS) ARE AVAILABLE UPON SPECIAL REQUEST. IN THIS CASE, PLEASE ADVISE OUR ORDER ENTRY DEPARTMENT THE MODEL AND SERIAL NUMBERS (FOUND ON THE MOTOR NAMEPLATE) , AND A DESCRIPTION OF THE COMPONENT REQUIRED. THEY WILL THEN FURNISH THE CURRENT PART NUMBER, PRICE AND AVAILABILITY.

(NOTE: OUR INTERNAL PART NUMBERS ARE SUBJECT TO CHANGE WITHOUT NOTICE, AND ARE NOT PUBLISHED).

PLEASE ADVISE IF YOU HAVE ANY QUESTIONS.

CUSTOMER:

PURCHASE ORDER #

Customer Tag:

TOSHIBA FILE #

MODEL #

HP / RPM / ENCL / FRAME:

DRIVE END BEARING:

OPPOSITE DRIVE END BEARING:

Prepared By: D. Schoeck

Date: 10-Jan-2019