

NOTE:
LIFTING RINGS
(2) 180° APART
FOR MOTOR
LIFTING ONLY

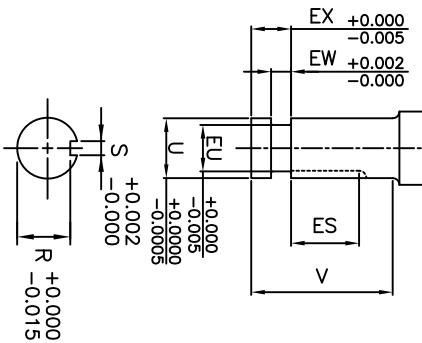
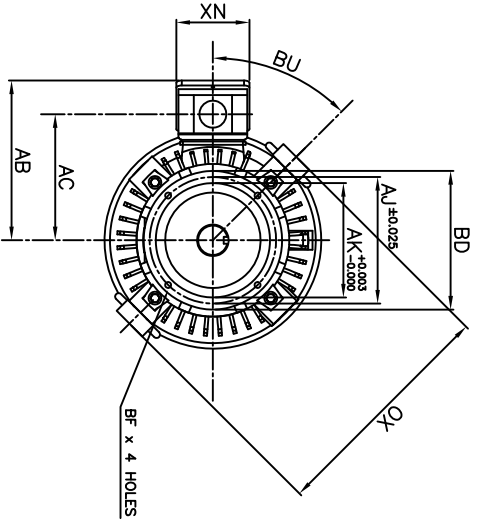
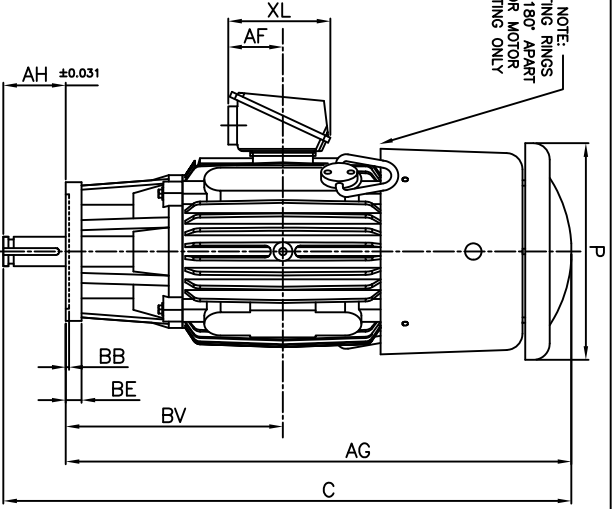

UNITS: INCHES

FRAME SIZE	MOTOR DIMENSIONS											P-FLANGE DIMENSIONS						SHAFT EXTENSION DIMENSIONS					
	AG	C	P	OX	BU	BB	BE	BF	BD	BV	AK	AU	AH	EU	U	V	R	S	ES	EW	EX		
250HP10	36.5	39.3	15.7	17.1	45°	0.25	1.0	0.44	10.0	15.7	8.25	9.125	2.75	0.875	1.125	2.75	0.986	0.25	1.28	0.375	0.75		
250HP12	36.5	39.3	15.7	17.1	45°	0.25	1.0	0.44	12.0	15.7	8.25	9.125	2.75	0.875	1.125	2.75	0.986	0.25	1.28	0.375	0.75		
250LP10	36.5	39.3	15.7	17.1	45°	0.25	1.0	0.44	10.0	15.7	8.25	9.125	2.75	1.250	1.625	2.75	1.416	0.375	1.28	0.375	0.75		
250LP12	36.5	39.3	15.7	17.1	45°	0.25	1.0	0.44	12.0	15.7	8.25	9.125	2.75	1.250	1.625	2.75	1.416	0.375	1.28	0.375	0.75		
280HP10	36.5	39.3	15.7	17.1	45°	0.25	1.0	0.44	10.0	15.7	8.25	9.125	2.75	0.875	1.125	2.75	0.986	0.25	1.28	0.375	0.75		
280HP12	36.5	39.3	15.7	17.1	45°	0.25	1.0	0.44	12.0	15.7	8.25	9.125	2.75	0.875	1.125	2.75	0.986	0.25	1.28	0.375	0.75		
280LP10	36.5	41.0	15.7	17.1	45°	0.25	1.0	0.44	10.0	15.7	8.25	9.125	4.50	1.750	2.125	4.50	1.845	0.50	3.03	0.375	0.75		
280LP12	36.5	41.0	15.7	17.1	45°	0.25	1.0	0.44	12.0	15.7	8.25	9.125	4.50	1.750	2.125	4.50	1.845	0.50	3.03	0.375	0.75		
280HP10	36.5	41.0	15.7	17.1	45°	0.25	1.0	0.44	10.0	15.7	8.25	9.125	4.50	1.250	1.625	4.50	1.416	0.375	3.03	0.375	0.75		
280HP12	36.5	41.0	15.7	17.1	45°	0.25	1.0	0.44	12.0	15.7	8.25	9.125	4.50	1.250	1.625	4.50	1.416	0.375	3.03	0.375	0.75		
280LP12	36.5	41.0	15.7	17.1	45°	0.25	1.0	0.44	12.0	15.7	8.25	9.125	4.50	1.250	1.625	4.50	1.416	0.375	3.03	0.375	0.75		
280HP16	36.5	41.0	15.7	17.1	45°	0.25	1.0	0.69	16.5	15.7	13.50	14.75	4.50	1.750	2.125	4.50	1.845	0.50	3.03	0.375	0.75		
280LP16	36.5	41.0	15.7	17.1	45°	0.25	1.0	0.69	16.5	15.7	13.50	14.75	4.50	1.250	2.125	4.50	1.416	0.375	3.03	0.375	0.75		
280HPA16	36.5	41.0	15.7	17.1	45°	0.25	1.0	0.69	16.5	15.7	13.50	14.75	4.50	1.250	1.625	4.50	1.416	0.375	1.28	0.375	0.75		

CONDUIT BOX DIMENSIONS							
MIN	WPT	AB	AC	AF	XL	XN	MAXIMUM WEIGHT
1.50	10.7	8.3	4.0	7.4	5.3	500	lbs

FRAME SIZE	LS	OS	BEARINGS
250HP	6309C3	6310C3	
250LP	6309C3	7309BEGAM x 2	
280HP	6309C3	6310C3	
280LP	6312C3	7309BEGAM x 2	

- NOTES:
- DIMENSION V REPRESENTS LENGTH OF STRAIGHT PART OF SHAFT
 - MAIN CONDUIT BOX MAY BE ROTATED IN 90° INCREMENTS
 - KEY DIMENSIONS EQUAL S x S x ES (MOTOR SUPPLIED WITH KEY)
 - MOTOR WEIGHT SHOWN IS MAXIMUM HORSEPOWER IN FRAME
 - STANDARD PRODUCT USE BI-DIRECTIONAL FAN, OPPOSITE ROTATION AVAILABLE ONLY BY CONNECTION CHANGE

CUSTOMER: _____ MOTOR MODEL NO.: _____ TAG NO's.: _____

P.O. NO.: _____ HP: _____ VOLTAGE: _____ RPM(SYN.): _____ HZ: _____

FRAME SIZE: _____ PRODUCT TYPE: VERTICAL SOLID SHAFT ROUND BODY P-FLANGE

COMMENTS: _____

PER: _____ DATE: _____

STANDARD (NO AUX. BOXES)

RTD AUX. BOX

SPACE HEATER AUX. BOX

BEARING RTD's

TOSHIBA RESERVES THE RIGHT TO MAKE CHANGES OF TECHNICAL IMPROVEMENT AND THE DATA MAY CHANGE WITHOUT NOTICE PRELIMINARY

DO NOT USE FOR CONSTRUCTION, INSTALLATION, OR APPLICATION PURPOSES UNLESS THE DRAWING IS MARKED AS CERTIFIED CERTIFIED

TOTALLY-ENCLOSED FAN-COOLED
VERTICAL SOLID SHAFT ROUND BODY P-FLANGE
3 PHASE INDUCTION MOTOR
F1 ASSEMBLY

TOSHIBA

TOSHIBA INTERNATIONAL CORPORATION

XT SERIES
VISIT OUR WEBSITE AT:
www.toshiba.com/ind



Issued Date	9/24/2019	Transmit #	
Issued By	dschoeck	Issued Rev	

TYPICAL MOTOR PERFORMANCE DATA

Model: 0304FTVB3PX-A

HP	kW	Pole	FL RPM	Frame	Voltage	Hz	Phase	FL Amps
30	22	4	1770	280LP10	460	60	3	35
Enclosure	IP	Ins. Class	S.F.	Duty	NEMA Nom. Eff.	NEMA Design	kVA Code	Ambient (°C)
TEFC	54	F	1.15	CONT	93.6	B	G	40 C

Load	HP	kW	Amperes	Efficiency (%)	Power Factor (%)
Full Load	30	22.4	34.9	93.4	86.0
¾ Load	22.50	16.8	27.0	93.4	83.5
½ Load	15.00	11.2	19.8	92.5	76.5
¼ Load	7.50	5.6	14.1	88.4	56.3
No Load			11.1		5.0
Locked Rotor			217		46.8

Torque				Rotor wk ² Inertia (lb-ft ²)
Full Load (lb-ft)	Locked Rotor (% FLT)	Pull Up (% FLT)	Break Down (% FLT)	
89	260	245	260	4.89

Safe Stall Time(s)		Sound Pressure dB(A) @ 1M	Bearings*		Approx. Motor Weight (lbs)
Cold	Hot		DE	NDE	
29	14	-	6312C3	7309B	500

*Bearings are the only recommended spare part(s).

Motor Options:
 Product Family:EQPIII Vertical Medium Thrust
 Mounting:10 P-Base (180-280 Frame),Shaft:LP Solid Shaft Medium Thrust

Customer	
Customer PO	
Sales Order	
Project #	

Tag:

All characteristics are average expected values.

TOSHIBA INTERNATIONAL CORPORATION · HOUSTON, TEXAS U.S.A.

Engineering	bmmamen	Doc. Written By	D. Suarez	Doc.# / Rev	MPCF-1119 / 1
Engr. Date	4/10/2014	Doc. Approved By	M. Campbell	Doc. Issued	9/20/2019



Issued Date	9/24/2019	Transmit #	
Issued By	dschoeck	Issued Rev	

SPEED TORQUE/CURRENT CURVE

Model: 0304FTVB3PX-A

HP	kW	Pole	FL RPM	Frame	Voltage	Hz	Phase	FL Amps
30	22	4	1770	280LP10	460	60	3	35
Enclosure	IP	Ins. Class	S.F.	Duty	NEMA Nom. Eff.	NEMA Design	kVA Code	Ambient (°C)
TEFC	54	F	1.15	CONT	93.6	B	G	40 C
Locked Rotor Amps	Rotor wk ² Inertia (lb-ft ²)	Torque				Pull Up (%)	Break Down (%)	
		Full Load (lb-ft)	Locked Rotor (%)					
217	4.89	89	260		245	260		

Design Values

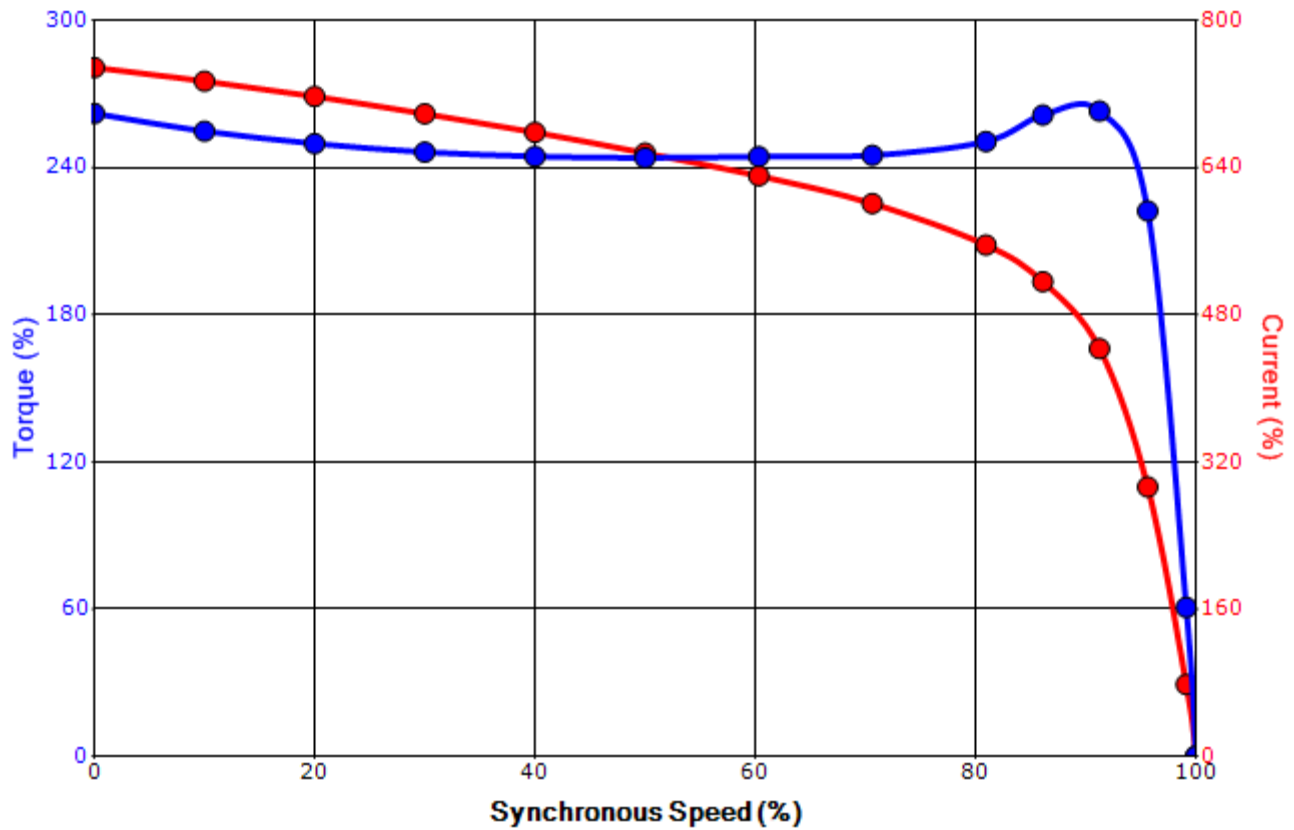

Customer		wk ² Load Inertia (lb-ft ²)	-
Customer PO		Load Type	-
Sales Order		Voltage (%)	100
Project #		Accel. Time	-

Tag:

All characteristics are average expected values.

TOSHIBA INTERNATIONAL CORPORATION · HOUSTON, TEXAS U.S.A.

Engineering	bmammen	Doc. Written By	D. Suarez	Doc.# / Rev	MPCF-1121/1
Engr. Date	4/10/2014	Doc. Approved By	M. Campbell	Doc. Issued	9/20/2019

Motor Connection Diagram
3 Leads - Delta Connection



Switch L1 and L2 to reverse rotation

Each lead may consist of more than one cable.
If multiple cables represent a single lead, each one
of them will be labeled with the appropriate lead number.