

ROTATION FROM NDE

CCW

CW

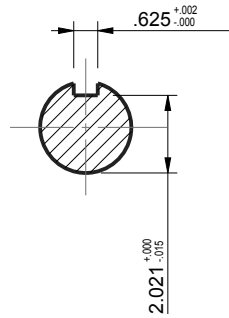
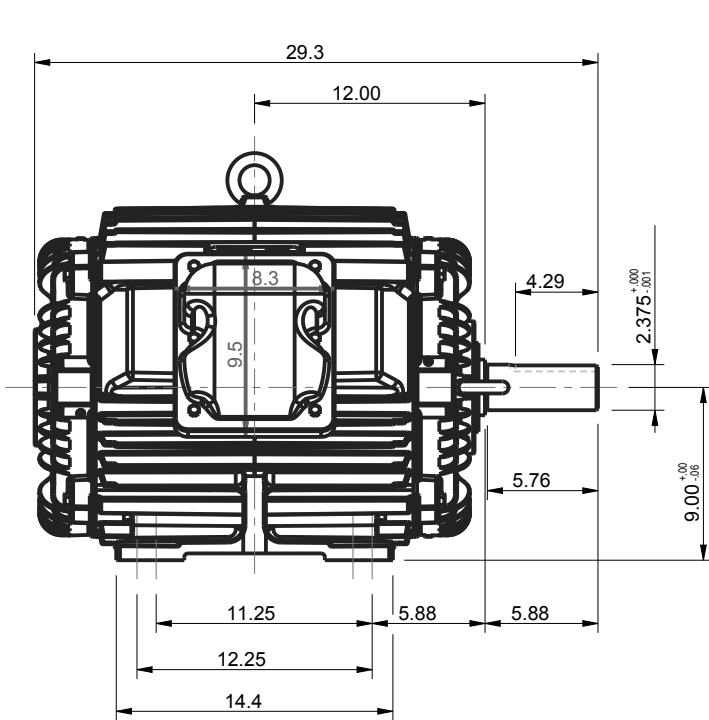

3.00" NPT CONDUIT

EYEBOLTS FOR VERTICAL LIFTING

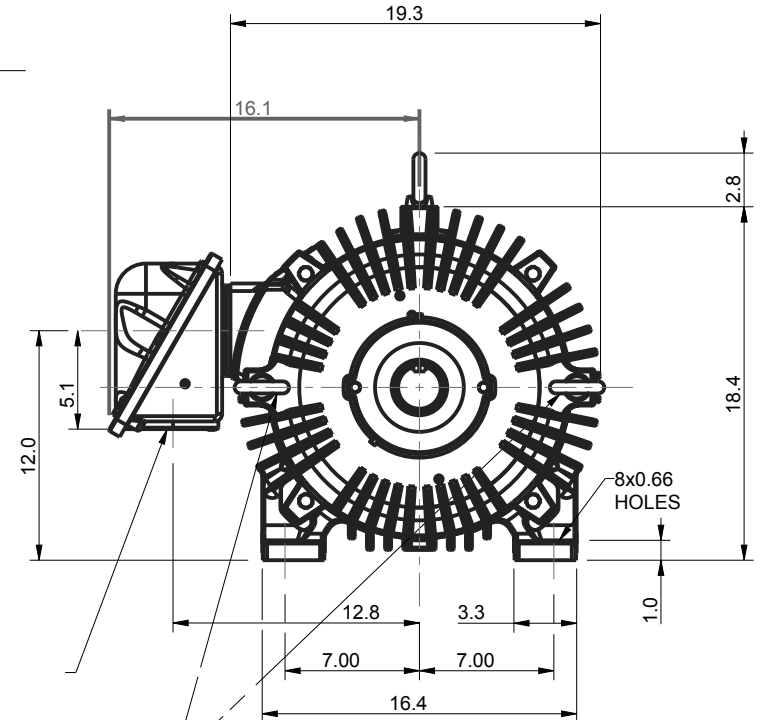

- NOTES:
1. MAIN CONDUIT BOX MAY BE ROTATED IN 90 INCREMENTS
 2. STANDARD PRODUCT USE BI-DIRECTIONAL FAN. OPPOSITE ROTATION AVAILABLE ONLY BY CONNECTION CHANGE.
 3. KEY DIMENSIONS EQUAL 0.625" x 0.625" x 4.25" (MOTOR SUPPLIED WITH KEY)

UNITS: INCHES

BEARINGS		APPROX. WEIGHT
LS	OS	
6314ZZC3	6312ZZC3	893 lbs

CUSTOMER: _____ MOTOR MODEL NO.: _____

P.O. NO.: _____ HP: _____ VOLTAGE: _____ RPM(SYN.): _____ HZ: _____

FRAME SIZE: 360T PRODUCT TYPE: COOLING TOWER

COMMENTS: _____

PER: _____ DATE: _____

TAG NUMBERS

- STANDARD (NO AUX. BOXES)
- RTD AUX. BOX
- SPACE HEATER AUX. BOX
- BEARING RTD's

TOSHIBA RESERVES THE RIGHT TO MAKE CHANGES OF TECHNICAL IMPROVEMENT AND THE DATA MAY CHANGE WITHOUT NOTICE

PRELIMINARY

DO NOT USE FOR CONSTRUCTION, INSTALLATION, OR APPLICATION PURPOSES UNLESS THE DRAWING IS MARKED AS CERTIFIED

CERTIFIED

TOSHIBA

TOSHIBA INTERNATIONAL CORPORATION

MDSLV505-07

TOTALLY ENCLOSED AIR OVER

3 PHASE INDUCTION MOTOR

F1 ASSEMBLY

SEVERE DUTY

EQP Global CT

XT SERIES

www.toshiba.com/ind

TYPICAL MOTOR PERFORMANCE DATA

Model: 0506FAGC41A-P

HP	kW	Pole	FL RPM	Frame	Voltage	Hz	Phase	FL Amps
50	37	6	1180	365T	575	60	3	47
Enclosure	IP	Ins. Class	S.F.	Duty	NEMA Nom. Eff.	NEMA Design	kVA Code	Ambient (°C)
TEAO	56	F	1.15	CONT	94.1	B		40 C

Load	HP	kW	Amperes	Efficiency (%)	Power Factor (%)
Full Load	50.00	37.3	47	94.6	83.5
¾ Load	37.50	28.0	36	94.6	80.5
½ Load	25.00	18.6	27	93.5	73.0
¼ Load	12.50	9.3	16.5	90.4	62.5
No Load			16.6		3.5
Locked Rotor			315		34.6

Torque				Rotor wk ² Inertia (lb-ft ²)
Full Load (lb-ft)	Locked Rotor (% FLT)	Pull Up (% FLT)	Break Down (% FLT)	
223	210	135	265	20.06

Safe Stall Time(s)		Sound Pressure dB(A) @ 1M	Bearings*		Approx. Motor Weight (lbs)
Cold	Hot		DE	NDE	
32	15	-	6314ZZC3	6312ZZC3	

*Bearings are the only recommended spare part(s).

Motor Options:
Product Family:EQP Global Cooling Tower
Mounting:Footed,Shaft:T Shaft

Customer	
Customer PO	
Sales Order	
Project #	

Tag:

All characteristics are average expected values.

TOSHIBA INTERNATIONAL CORPORATION · HOUSTON, TEXAS U.S.A.

Engineering	zxie	Doc. Written By	D. Suarez	Doc.# / Rev	MPCF-1119 / 0
Engr. Date	7/15/2024	Doc. Approved By	M. Campbell	Doc. Issued	6/8/2011

Issued Date	12/19/2024	Transmit #	
Issued By	dschoeck	Issued Rev	

SPEED TORQUE/CURRENT CURVE

Model: 0506FAGC41A-P

HP	kW	Pole	FL RPM	Frame	Voltage	Hz	Phase	FL Amps
50	37	6	1180	365T	575	60	3	47
Enclosure	IP	Ins. Class	S.F.	Duty	NEMA Nom. Eff.	NEMA Design	kVA Code	Ambient (°C)
TEAO	56	F	1.15	CONT	94.1	B		40 C
Locked Rotor Amps	Rotor wk ² Inertia (lb-ft ²)	Torque						Break Down (%)
		Full Load (lb-ft)	Locked Rotor (%)	Pull Up (%)				
315	20.06	223	210	135			265	

Design Values

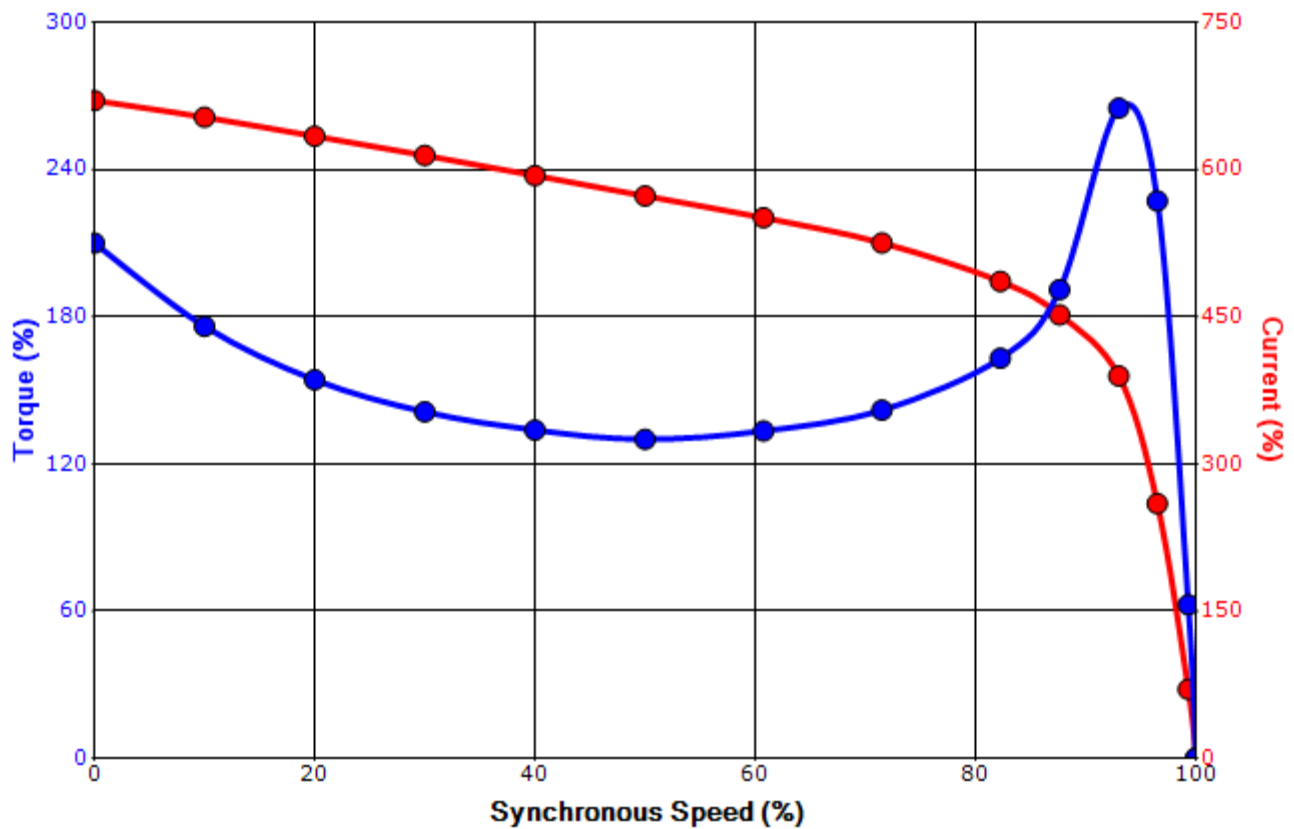

Customer		wk ² Load Inertia (lb-ft ²)	-
Customer PO		Load Type	-
Sales Order		Voltage (%)	100
Project #		Accel. Time	-

Tag:

All characteristics are average expected values.

TOSHIBA INTERNATIONAL CORPORATION · HOUSTON, TEXAS U.S.A.

Engineering	zxie	Doc. Written By	D. Suarez	Doc.# / Rev	MPCF-1121 / 0
Engr. Date	7/15/2024	Doc. Approved By	M. Campbell	Doc. Issued	6/8/2011

Motor Connection Diagrams
6 Leads

Across the Line Starting / Run - Delta:



Alternate Starting Connection - Wye:



Switch L1 and L2 to reverse rotation