

NOTE:
LIFTING RINGS
(2) 180° APART
FOR MOTOR
LIFTING ONLY

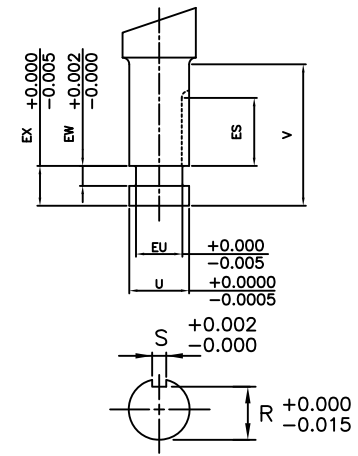
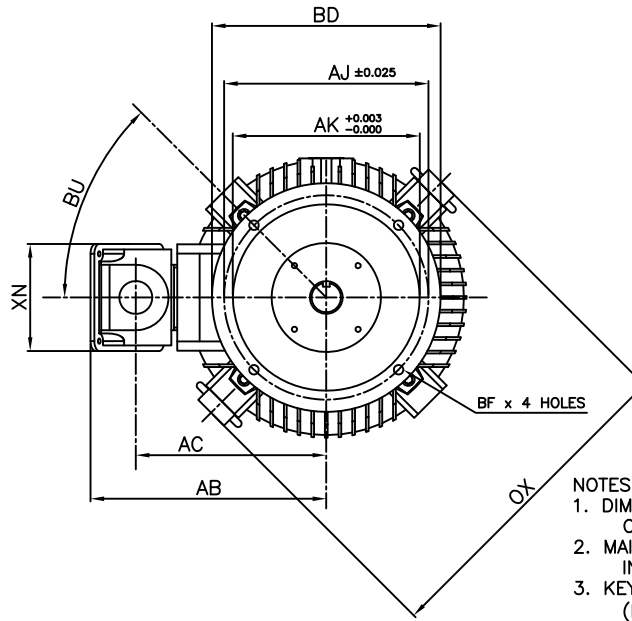

- NOTES:
1. DIMENSION V REPRESENTS LENGTH OF STRAIGHT PART OF SHAFT
 2. MAIN CONDUIT BOX MAY BE ROTATED IN 90° INCREMENTS
 3. KEY DIMENSIONS EQUAL S x S x ES (MOTOR SUPPLIED WITH KEY)
 4. MOTOR WEIGHT SHOWN IS MAXIMUM HORSEPOWER IN FRAME
 5. STANDARD PRODUCT USE BI-DIRECTIONAL FAN. OPPOSITE ROTATION AVAILABLE ONLY BY CONNECTION CHANGE

UNITS: INCHES

FRAME SIZE	MOTOR DIMENSIONS				P-FLANGE DIMENSIONS								SHAFT EXTENSION DIMENSIONS									
	AG	C	P	OX	BU	BB	BE	BF	BD	BV	AK	AJ	AH	EU	U	V	R	S	ES	EW	EX	
400HP16	45.4	49.9	19.8	23.6	45°	0.25	1.0	0.69	16.5	19.0	13.50	14.75	4.50	1.25	1.625	4.50	1.416	0.375	3.03	0.375	0.75	
400HPH16	45.4	49.9	19.8	23.6	45°	0.25	1.0	0.69	16.5	19.0	13.50	14.75	4.50	1.75	2.125	4.50	1.845	0.500	3.03	0.375	0.75	
400LP16	45.4	49.9	19.8	23.6	45°	0.25	1.0	0.69	16.5	19.0	13.50	14.75	4.50	1.75	2.125	4.50	1.845	0.500	3.03	0.375	0.75	

CONDUIT BOX DIMENSIONS						MAXIMUM WEIGHT
AA(NPT)	AB	AC	AF	XL	XN	
3.00	17.1	13.8	5.2	9.1	7.8	500 lbs

FRAME SIZE	BEARINGS	
	LS	OS
HP	6313C3	6313C3
LP	6313C3	7313BEGAM x 2

CUSTOMER: _____ MOTOR MODEL NO.: _____ TAG NO's.: _____

P.O. NO.: _____ HP: _____ VOLTAGE: _____ RPM(SYN.): _____ Hz: _____

FRAME SIZE: _____ PRODUCT TYPE: VERTICAL SOLID SHAFT ROUND BODY P-FLANGE

COMMENTS: _____

PER: _____ DATE: _____

STANDARD (NO AUX. BOXES)

RTD AUX. BOX

SPACE HEATER AUX. BOX

BEARING RTD's

TOSHIBA RESERVES THE RIGHT TO MAKE CHANGES OF TECHNICAL IMPROVEMENT AND THE DATA MAY CHANGE WITHOUT NOTICE PRELIMINARY

DO NOT USE FOR CONSTRUCTION, INSTALLATION, OR APPLICATION PURPOSES UNLESS THE DRAWING IS MARKED AS CERTIFIED CERTIFIED

TOSHIBA

TOSHIBA INTERNATIONAL CORPORATION

TOTALLY-ENCLOSED FAN-COOLED
VERTICAL SOLID SHAFT ROUND BODY P-FLANGE
3 PHASE INDUCTION MOTOR
F1 ASSEMBLY

XT SERIES

VISIT OUR WEBSITE AT:
www.toshiba.com/ind



Issued Date	9/24/2019	Transmit #	
Issued By	dschoeck	Issued Rev	

TYPICAL MOTOR PERFORMANCE DATA

Model: 1002FTVB3RW-A

HP	kW	Pole	FL RPM	Frame	Voltage	Hz	Phase	FL Amps
100	75	2	3555	400HP16	460	60	3	112
Enclosure	IP	Ins. Class	S.F.	Duty	NEMA Nom. Eff.	NEMA Design	kVA Code	Ambient (°C)
TEFC	54	F	1.15	CONT	95	B	G	40 C

Load	HP	kW	Amperes	Efficiency (%)	Power Factor (%)
Full Load	100	74.6	112.0	95.0	87.8
¾ Load	75.00	55.9	86.8	95.0	86.2
½ Load	50.00	37.3	62.5	94.8	81.0
¼ Load	25.00	18.6	41.9	87.7	63.7
No Load			26.0		6.5
Locked Rotor			725		34.1

Torque				Rotor wk ² Inertia (lb-ft ²)
Full Load (lb-ft)	Locked Rotor (% FLT)	Pull Up (% FLT)	Break Down (% FLT)	
148	215	145	260	17.36

Safe Stall Time(s)		Sound Pressure dB(A) @ 1M	Bearings*		Approx. Motor Weight (lbs)
Cold	Hot		DE	NDE	
15	5	-	6313C3	6313C3	1300

*Bearings are the only recommended spare part(s).

Motor Options:

Product Family:EQPIII Vertical Normal Thrust
Mounting:16 P-Base (280-440 Frame),Shaft:HP Solid Shaft Normal Thrust

Customer	
Customer PO	
Sales Order	
Project #	

Tag:

All characteristics are average expected values.

TOSHIBA INTERNATIONAL CORPORATION · HOUSTON, TEXAS U.S.A.

Engineering	gminetos	Doc. Written By	D. Suarez	Doc.# / Rev	MPCF-1119 / 1
Engr. Date	7/25/2013	Doc. Approved By	M. Campbell	Doc. Issued	9/20/2019



Issued Date	9/24/2019	Transmit #	
Issued By	dschoeck	Issued Rev	

SPEED TORQUE/CURRENT CURVE

Model: 1002FTVB3RW-A

HP	kW	Pole	FL RPM	Frame	Voltage	Hz	Phase	FL Amps
100	75	2	3555	400HP16	460	60	3	112
Enclosure	IP	Ins. Class	S.F.	Duty	NEMA Nom. Eff.	NEMA Design	kVA Code	Ambient (°C)
TEFC	54	F	1.15	CONT	95	B	G	40 C
Locked Rotor Amps	Rotor wk ² Inertia (lb-ft ²)	Torque				Pull Up (%)	Break Down (%)	
		Full Load (lb-ft)	Locked Rotor (%)					
725	17.36	148	215		145	260		

Design Values

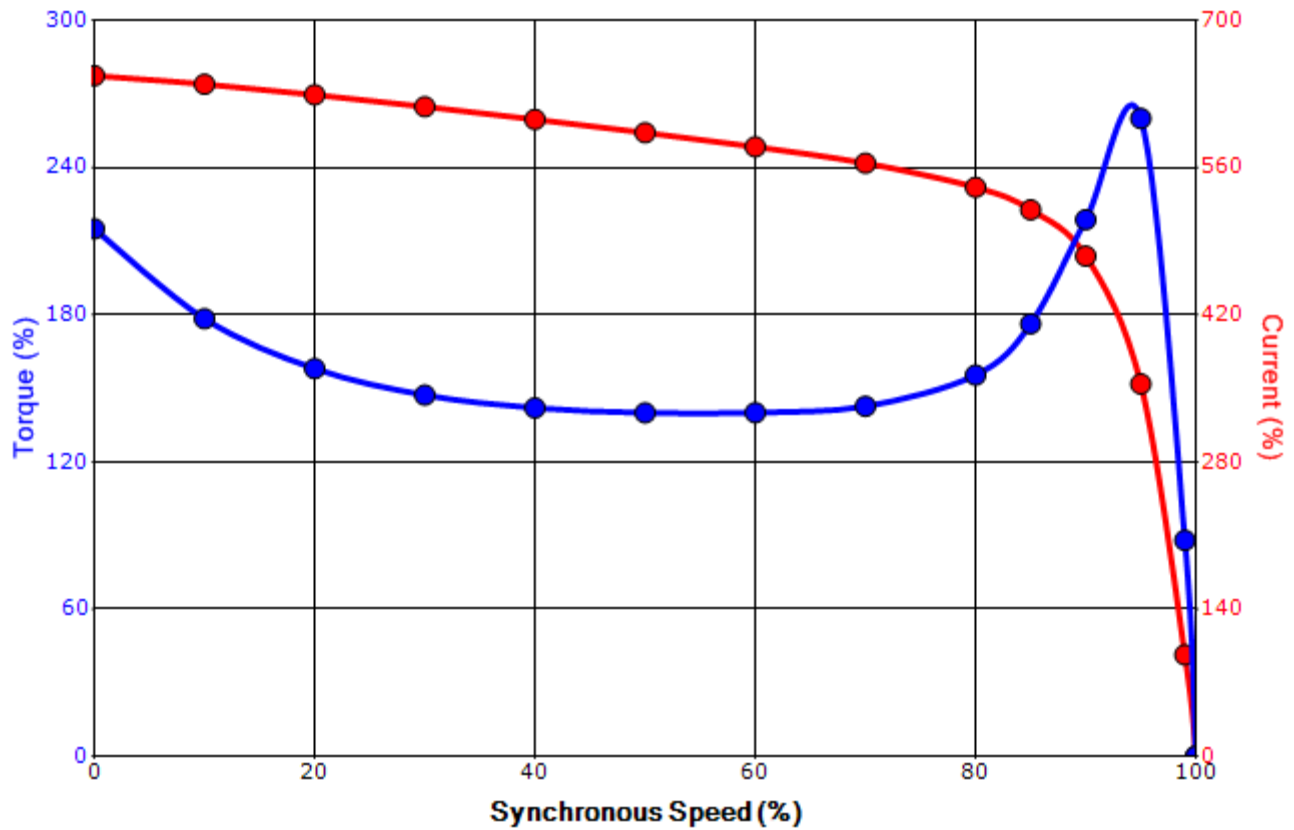

Customer		wk ² Load Inertia (lb-ft ²)	-
Customer PO		Load Type	-
Sales Order		Voltage (%)	100
Project #		Accel. Time	-

Tag:

All characteristics are average expected values.

TOSHIBA INTERNATIONAL CORPORATION · HOUSTON, TEXAS U.S.A.

Engineering	gminetos	Doc. Written By	D. Suarez	Doc.# / Rev	MPCF-1121/1
Engr. Date	7/25/2013	Doc. Approved By	M. Campbell	Doc. Issued	9/20/2019

Motor Connection Diagram
3 Leads - Delta Connection



Switch L1 and L2 to reverse rotation

Each lead may consist of more than one cable.
If multiple cables represent a single lead, each one
of them will be labeled with the appropriate lead number.