

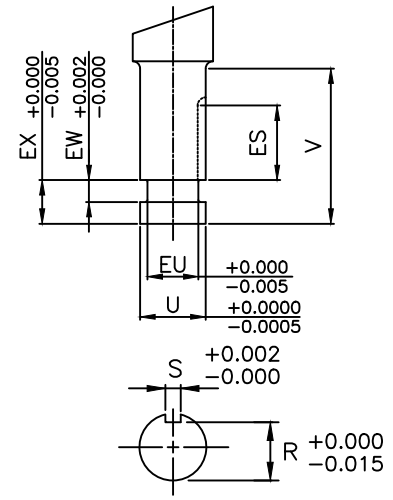

NOTE:
LIFTING RINGS
(2) 180° APART
FOR MOTOR
LIFTING ONLY

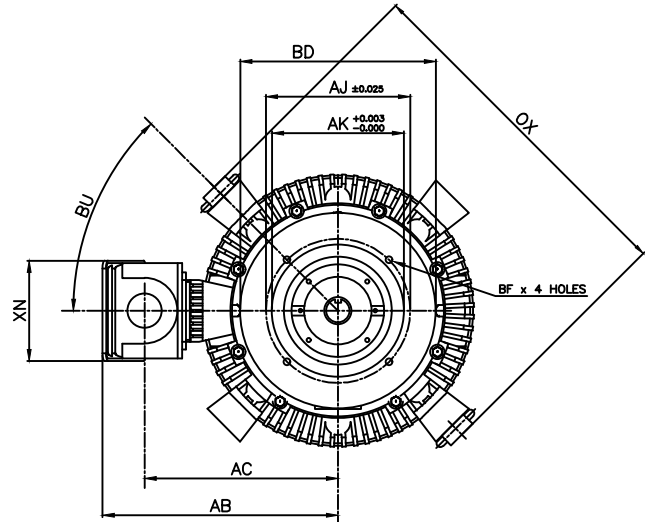
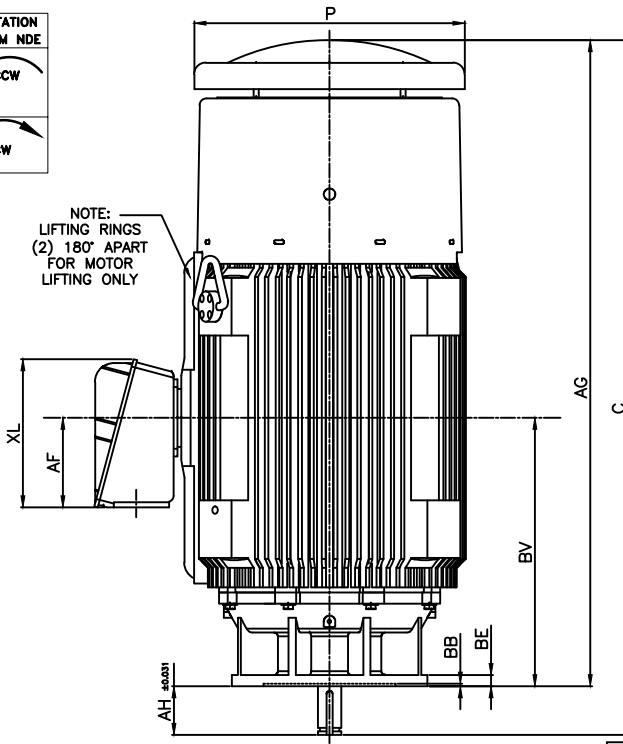

- NOTES:
1. DIMENSION V REPRESENTS LENGTH OF STRAIGHT PART OF SHAFT
 2. MAIN CONDUIT BOX MAY BE ROTATED IN 90° INCREMENTS
 3. KEY DIMENSIONS EQUAL S x S x ES (MOTOR SUPPLIED WITH KEY)
 4. MOTOR WEIGHT SHOWN IS MAXIMUM HORSEPOWER IN FRAME
 5. STANDARD PRODUCT USE BI-DIRECTIONAL FAN. OPPOSITE ROTATION AVAILABLE ONLY BY CONNECTION CHANGE

UNITS: INCHES

FRAME SIZE	MOTOR DIMENSIONS				P-FLANGE DIMENSIONS							
	AG	C	P	OX	BU	BB	BE	BF	BD	BV	AK	AJ
N449HP20	66.1	71.1	27.7	35.9	45°	0.25	1.0	0.69	20.0	27.5	13.50	14.75
N449HP24	66.1	71.1	27.7	35.9	45°	0.25	1.0	0.69	24.0	27.5	13.50	14.75
N449LP20	66.1	71.1	27.7	35.9	45°	0.25	1.0	0.69	20.0	27.5	13.50	14.75
N449LP24	66.1	71.1	27.7	35.9	45°	0.25	1.0	0.69	24.0	27.5	13.50	14.75

POLE SPEED	HORSE POWER	SHAFT EXTENSION DIMENSIONS									
		AH	EU	U	V	R	S	ES	EW	EX	
2	250~350	4.50	1.75	2.125	4.50	1.845	0.500	3.03	0.375	0.75	
	350~300	4.50	1.75	2.125	4.50	1.845	0.500	3.03	0.375	0.75	
4	350	5.00	2.00	2.375	5.00	2.021	0.625	3.53	0.375	0.75	
	200	4.50	1.75	2.125	4.50	1.845	0.500	3.03	0.375	0.75	
6	250	5.00	2.00	2.375	5.00	2.021	0.625	3.53	0.375	0.75	
	300~350	5.00	2.25	2.625	5.00	2.275	0.625	3.53	0.375	0.75	
8	150	5.00	2.00	2.375	5.00	2.021	0.625	3.53	0.375	0.75	
	200~250	5.00	2.25	2.625	5.00	2.275	0.625	3.53	0.375	0.75	

CONDUIT BOX DIMENSIONS						MAXIMUM WEIGHT
AA/NPT	AB	AC	AF	XL	XN	
3.00	24.1	19.8	9.2	15.2	10.3	3800 LBS

FRAME SIZE	BEARINGS	
	LS	OS
2 POLE HP	6313C3	6315C3
2 POLE LP	6313C3	7315BEGAM x 2
4~8 POLE HP	6318C3	6315C3
4~8 POLE LP	6318C3	7315BEGAM x 2

CUSTOMER: _____ MOTOR MODEL NO.: _____ TAG NO's.: _____

P.O. NO.: _____ HP: _____ VOLTAGE: _____ RPM(SYN.): _____ Hz: _____

FRAME SIZE: _____ PRODUCT TYPE: VERTICAL SOLID SHAFT ROUND BODY P-FLANGE

COMMENTS: _____

PER: _____ DATE: _____

STANDARD (NO AUX. BOXES)

RTD AUX. BOX

SPACE HEATER AUX. BOX

BEARING RTD's

TOSHIBA RESERVES THE RIGHT TO MAKE CHANGES OF TECHNICAL IMPROVEMENT AND THE DATA MAY CHANGE WITHOUT NOTICE PRELIMINARY

DO NOT USE FOR CONSTRUCTION, INSTALLATION, OR APPLICATION PURPOSES UNLESS THE DRAWING IS MARKED AS CERTIFIED CERTIFIED

TOSHIBA
TOSHIBA INTERNATIONAL CORPORATION

TOTALLY-ENCLOSED FAN-COOLED
VERTICAL SOLID SHAFT ROUND BODY P-FLANGE
3 PHASE INDUCTION MOTOR
F1 ASSEMBLY

XT SERIES
VISIT OUR WEBSITE AT:
www.toshiba.com/ind

TYPICAL MOTOR PERFORMANCE DATA

Model: 2006FTVB3SW-A

HP	kW	Pole	FL RPM	Frame	Voltage	Hz	Phase	FL Amps
200	150	6	1185	N449HP20	460	60	3	234
Enclosure	IP	Ins. Class	S.F.	Duty	NEMA Nom. Eff.	NEMA Design	kVA Code	Ambient (°C)
TEFC	54	F	1.15	CONT	96.2	B		40 C

Load	HP	kW	Amperes	Efficiency (%)	Power Factor (%)
Full Load	200.00	149.1	234	96.2	83.1
¾ Load	150.00	111.9	191	95.5	80.3
½ Load	100.00	74.6	143	93.8	72.7
¼ Load	50.00	37.3	105	88.1	50.2
No Load			89.0		3.7
Locked Rotor			1398		23.3

Torque				Rotor wk ²
Full Load (lb-ft)	Locked Rotor (% FLT)	Pull Up (% FLT)	Break Down (% FLT)	Inertia (lb-ft ²)
886	150	125	240	130.94

Safe Stall Time(s)		Sound Pressure dB(A) @ 1M	Bearings*		Approx. Motor Weight (lbs)
Cold	Hot		DE	NDE	
26	13	-	6318C3	6315C3	3200

*Bearings are the only recommended spare part(s).

Motor Options:
Product Family:EQPIII Vertical Normal Thrust
Mounting:20 P-Base (440 Frame),Shaft:HP Solid Shaft Normal Thrust

Customer	
Customer PO	
Sales Order	
Project #	

Tag:

All characteristics are average expected values.

TOSHIBA INTERNATIONAL CORPORATION · HOUSTON, TEXAS U.S.A.

Engineering	gminetos	Doc. Written By	D. Suarez	Doc.# / Rev	MPCF-1119 / 0
Engr. Date	7/25/2013	Doc. Approved By	M. Campbell	Doc. Issued	6/8/2011

SPEED TORQUE/CURRENT CURVE

Model: 2006FTVB3SW-A

HP	kW	Pole	FL RPM	Frame	Voltage	Hz	Phase	FL Amps
200	150	6	1185	N449HP20	460	60	3	234
Enclosure	IP	Ins. Class	S.F.	Duty	NEMA Nom. Eff.	NEMA Design	kVA Code	Ambient (°C)
TEFC	54	F	1.15	CONT	96.2	B		40 C
Locked Rotor Amps	Rotor wk ² Inertia (lb-ft ²)	Torque						Break Down (%)
		Full Load (lb-ft)	Locked Rotor (%)	Pull Up (%)				
1398	130.94	886	150	125			240	

Design Values

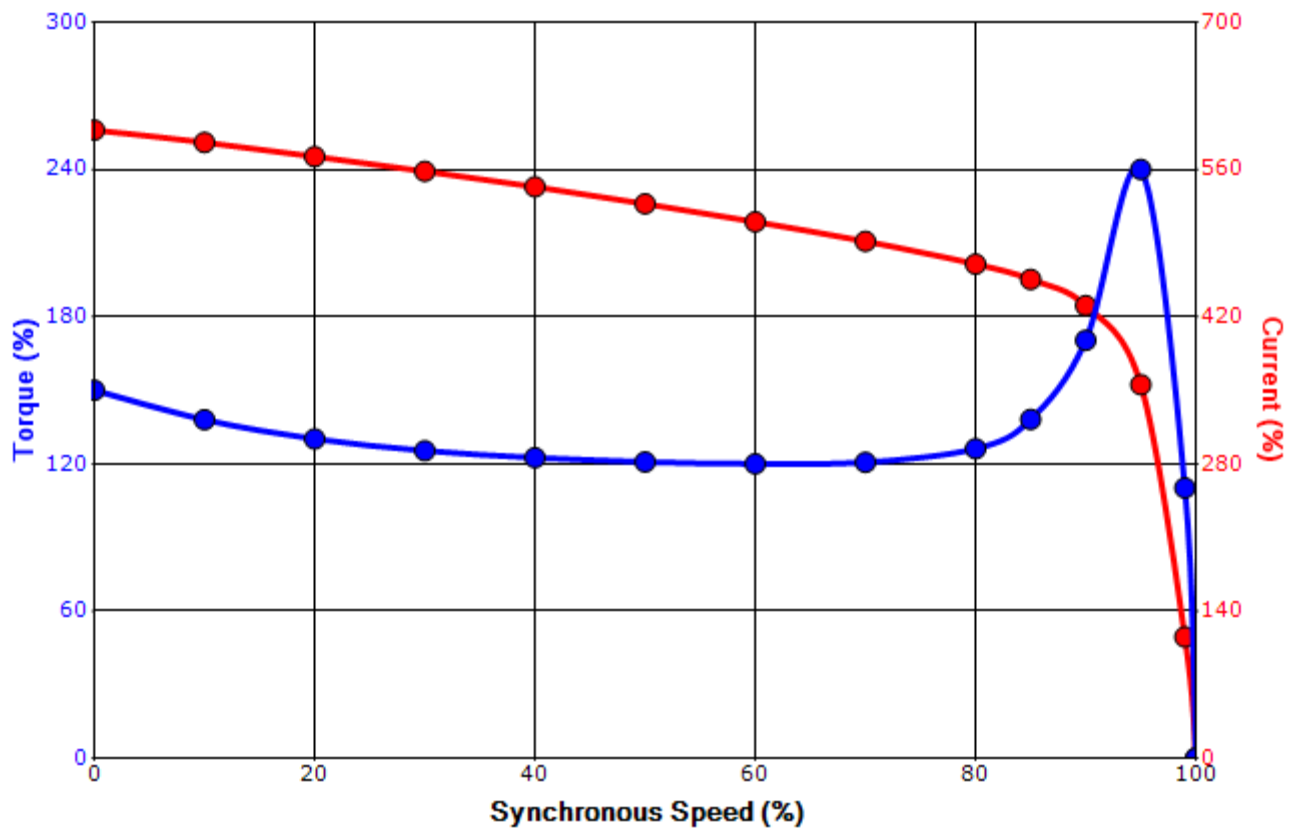

Customer		wk ² Load Inertia (lb-ft ²)	-
Customer PO		Load Type	-
Sales Order		Voltage (%)	100
Project #		Accel. Time	-

Tag:

All characteristics are average expected values.

TOSHIBA INTERNATIONAL CORPORATION · HOUSTON, TEXAS U.S.A.

Engineering	gminetos	Doc. Written By	D. Suarez	Doc.# / Rev	MPCF-1121 / 0
Engr. Date	7/25/2013	Doc. Approved By	M. Campbell	Doc. Issued	6/8/2011

Motor Connection Diagram
3 Leads - Delta Connection



Switch L1 and L2 to reverse rotation

Each lead may consist of more than one cable.
If multiple cables represent a single lead, each one
of them will be labeled with the appropriate lead number.