

C<sub>1</sub> FOR 400HP/350HP - 2 POLES (NOTE 6)

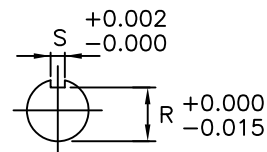
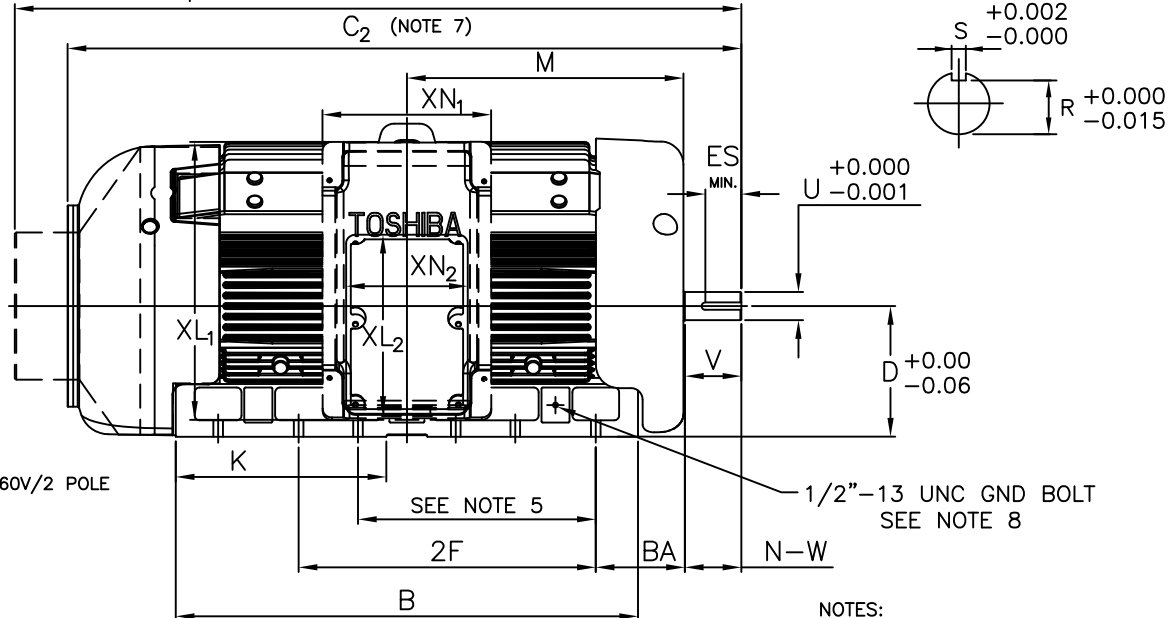

UNITS: INCHES

FRAME SIZE	MOTOR DIMENSIONS											
	A	B	C <sub>1</sub>	C <sub>2</sub>	D	G	J	K	M	O	P	T
B447TS/B449TS	22.0	38.9	61.1	56.7	11.00	1.4	4.5	17.7	23.3	25.1	27.9	1.3

FRAME SIZE	CONDUIT BOX											
	AA[NPT]	AB <sub>1</sub>	AB <sub>2</sub>	AC <sub>1</sub>	AC <sub>2</sub>	AE	AF <sub>1</sub>	AF <sub>2</sub>	XL <sub>1</sub>	XL <sub>2</sub>	XN <sub>1</sub>	XN <sub>2</sub>
B447TS/B449TS	4.00	29.8	23.8	22.4	19.6	11.00	9.6	9.1	23.4	15.2	14.2	10.2

FRAME SIZE	MOUNTING				SHAFT EXTENSION			KEY SEAT			BEARINGS		MAXIMUM WEIGHT
	E	2F	H	BA	N-W	V	U	R	S	ES	LS	OS	
B447TS/B449TS	9.00	20.00/25.00	0.81	7.50	4.75	4.50	2.375	2.021	0.625	3.03	6313C3	6313C3	4000 lbs.

- NOTES:
- DIMENSION V REPRESENTS LENGTH OF STRAIGHT PART OF SHAFT
  - MAIN CONDUIT BOX MAY BE ROTATED IN 90° INCREMENTS
  - KEY DIMENSIONS EQUAL S x s x 3.00 (MOTOR SUPPLIED WITH KEY).
  - MOTOR WEIGHT SHOWN IS MAXIMUM HORSEPOWER IN FRAME.
  - THIS DIMENSION EQUALS 2F FOR B447T MOUNTING.
  - 400HP/350HP 2 POLE STANDARD PRODUCT USE UNI-DIRECTIONAL FAN. OPPOSITE ROTATION AVAILABLE ONLY BY FAN AND CONNECTION CHANGE.
  - 300HP/250HP 2 POLE STANDARD PRODUCT USE BI-DIRECTIONAL FAN. OPPOSITE ROTATION AVAILABLE BY CONNECTION CHANGE.
  - FRAME GROUND BOLT STANDARD ON 841 PRODUCT.

CUSTOMER: \_\_\_\_\_ MOTOR MODEL NO.: \_\_\_\_\_

P.O. NO.: \_\_\_\_\_ HP: \_\_\_\_\_ VOLTAGE: \_\_\_\_\_ RPM(SYN.): \_\_\_\_\_ Hz: \_\_\_\_\_

FRAME SIZE: \_\_\_\_\_ PRODUCT TYPE: TEFC EQP III SD & 841

COMMENTS: \_\_\_\_\_

PER: \_\_\_\_\_ DATE: \_\_\_\_\_

TAG NO's: \_\_\_\_\_

<input checked="" type="checkbox"/>	STANDARD (NO AUX. BOXES)
<input type="checkbox"/>	RTD AUX. BOX
<input type="checkbox"/>	SPACE HEATER AUX. BOX
<input type="checkbox"/>	BEARING RTD's

TOSHIBA RESERVES THE RIGHT TO MAKE CHANGES OF TECHNICAL IMPROVEMENT AND THE DATA MAY CHANGE WITHOUT NOTICE  PRELIMINARY

DO NOT USE FOR CONSTRUCTION, INSTALLATION, OR APPLICATION PURPOSES UNLESS THE DRAWING IS MARKED AS CERTIFIED  CERTIFIED

# TOSHIBA

TOSHIBA INTERNATIONAL CORPORATION

TOTALLY-ENCLOSED FAN-COOLED  
HORIZONTAL FOOT-MOUNTED  
3 PHASE INDUCTION MOTOR  
F1 ASSEMBLY

## XT SERIES

VISIT OUR WEBSITE AT:  
[www.toshiba.com/ind](http://www.toshiba.com/ind)

**TYPICAL MOTOR PERFORMANCE DATA**

Model: 3002XDSB41B

HP	kW	Pole	FL RPM	Frame	Voltage	Hz	Phase	FL Amps
300	224	2	3580	B449TS	460	60	3	325
Enclosure	IP	Ins. Class	S.F.	Duty	NEMA Nom. Eff.	NEMA Design	kVA Code	Ambient (°C)
TEFC	56	F	1.15	CONT	95.8	A		40 C

Load	HP	kW	Amperes	Efficiency (%)	Power Factor (%)
Full Load	300.00	223.7	324	95.8	90.4
¾ Load	225.00	167.8	248	94.7	89.5
½ Load	150.00	111.9	176	92.4	86.2
¼ Load	75.00	55.9	111	85.9	73.6
No Load			73.9		7.2
Locked Rotor			2358		22.7

Torque				Rotor wk <sup>2</sup>
Full Load (lb-ft)	Locked Rotor (% FLT)	Pull Up (% FLT)	Break Down (% FLT)	Inertia (lb-ft <sup>2</sup> )
440	165	135	255	135.14

Safe Stall Time(s)		Sound Pressure dB(A) @ 1M	Bearings*		Approx. Motor Weight (lbs)
Cold	Hot		DE	NDE	
35	15	85	6313C3	6313C3	

\*Bearings are the only recommended spare part(s).

**Motor Options:**  
Product Family:EQP Global 841  
Mounting:Footed,Shaft:TS Shaft

Customer	
Customer PO	
Sales Order	
Project #	

Tag:

All characteristics are average expected values.

**TOSHIBA INTERNATIONAL CORPORATION · HOUSTON, TEXAS U.S.A.**

Engineering	SSuryani	Doc. Written By	D. Suarez	Doc.# / Rev	MPCF-1119 / 0
Engr. Date	4/13/2020	Doc. Approved By	M. Campbell	Doc. Issued	6/8/2011

**SPEED TORQUE/CURRENT CURVE**

Model: 3002XDSB41B

HP	kW	Pole	FL RPM	Frame	Voltage	Hz	Phase	FL Amps
300	224	2	3580	B449TS	460	60	3	325
Enclosure	IP	Ins. Class	S.F.	Duty	NEMA Nom. Eff.	NEMA Design	kVA Code	Ambient (°C)
TEFC	56	F	1.15	CONT	95.8	A		40 C
Locked Rotor Amps	Rotor wk <sup>2</sup> Inertia (lb-ft <sup>2</sup> )	Torque						Break Down (%)
		Full Load (lb-ft)	Locked Rotor (%)	Pull Up (%)				
2358	135.14	440	165	135			255	

**Design Values**

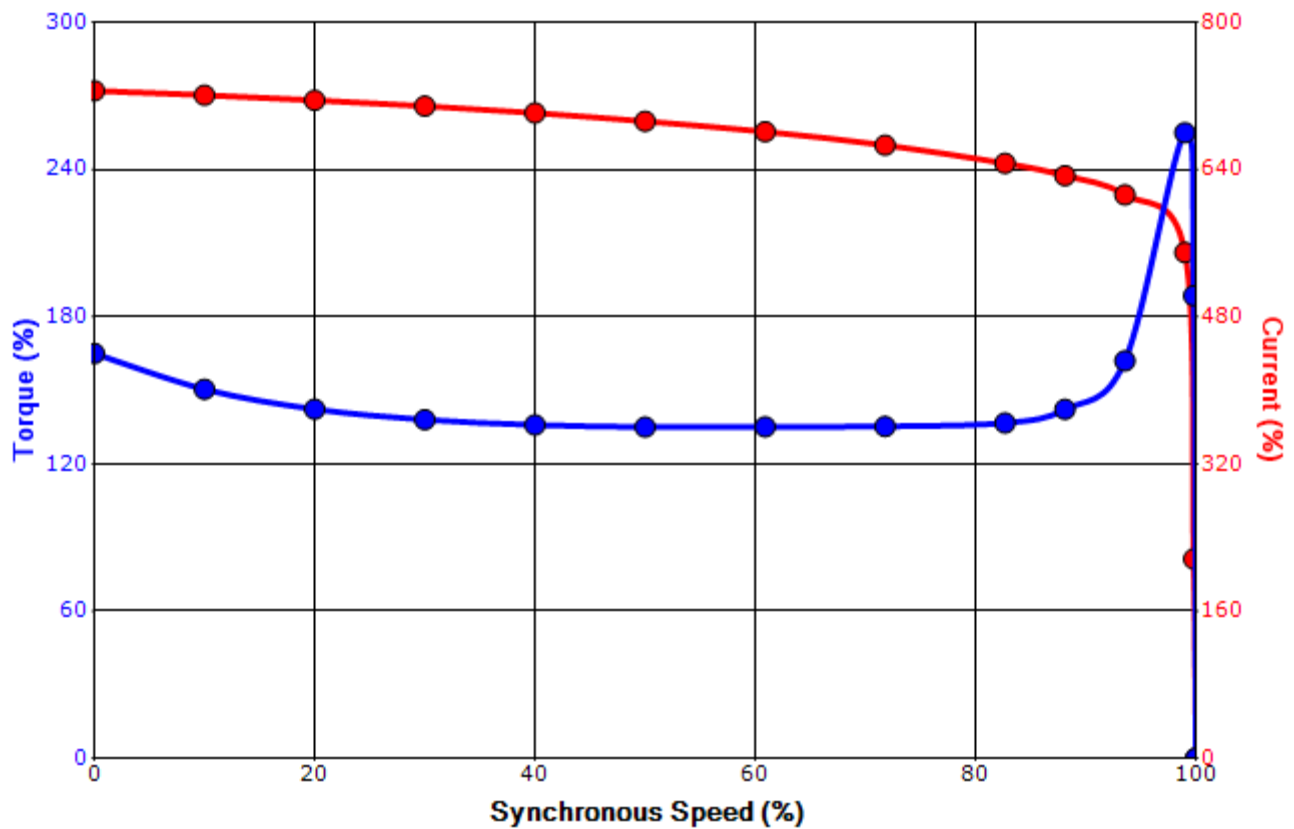

Customer		wk <sup>2</sup> Load Inertia (lb-ft <sup>2</sup> )	-
Customer PO		Load Type	-
Sales Order		Voltage (%)	100
Project #		Accel. Time	-

Tag:

All characteristics are average expected values.

**TOSHIBA INTERNATIONAL CORPORATION · HOUSTON, TEXAS U.S.A.**

Engineering	SSuryani	Doc. Written By	D. Suarez	Doc.# / Rev	MPCF-1121 / 0
Engr. Date	4/13/2020	Doc. Approved By	M. Campbell	Doc. Issued	6/8/2011

**Motor Connection Diagram**  
3 Leads - Delta Connection

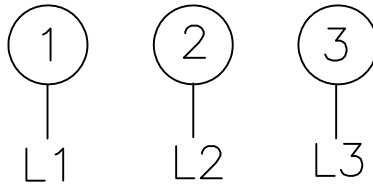
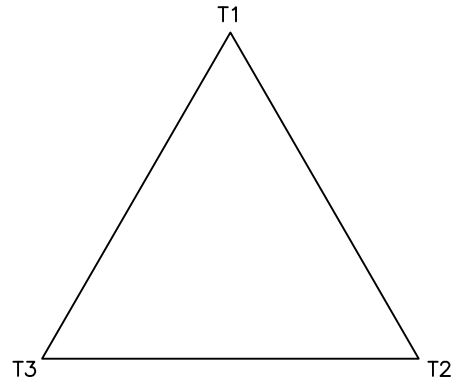

Switch L1 and L2 to reverse rotation

Each lead may consist of more than one cable.  
If multiple cables represent a single lead, each one  
of them will be labeled with the appropriate lead number.