

C₁ FOR 400HP/350HP - 2 POLES (NOTE 6)

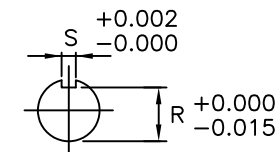
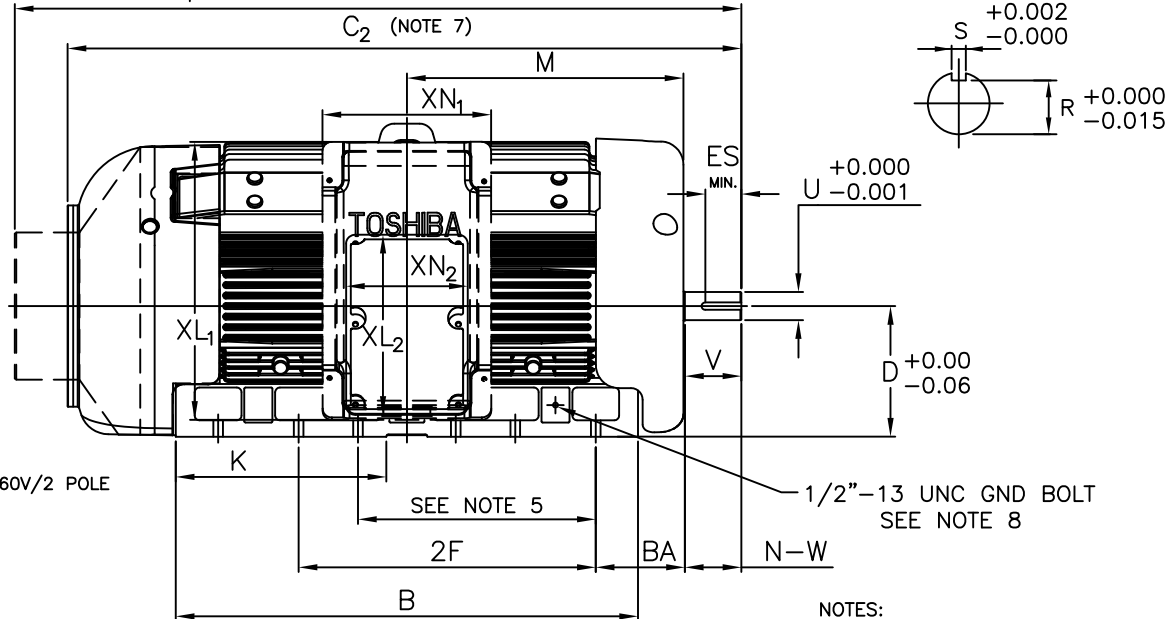

UNITS: INCHES

FRAME SIZE	MOTOR DIMENSIONS											
	A	B	C ₁	C ₂	D	G	J	K	M	O	P	T
B447TS/B449TS	22.0	38.9	61.1	56.7	11.00	1.4	4.5	17.7	23.3	25.1	27.9	1.3

FRAME SIZE	CONDUIT BOX											
	AA[NPT]	AB ₁	AB ₂	AC ₁	AC ₂	AE	AF ₁	AF ₂	XL ₁	XL ₂	XN ₁	XN ₂
B447TS/B449TS	4.00	29.8	23.8	22.4	19.6	11.00	9.6	9.1	23.4	15.2	14.2	10.2

FRAME SIZE	MOUNTING				SHAFT EXTENSION			KEY SEAT			BEARINGS		MAXIMUM WEIGHT
	E	2F	H	BA	N-W	V	U	R	S	ES	LS	OS	
B447TS/B449TS	9.00	20.00/25.00	0.81	7.50	4.75	4.50	2.375	2.021	0.625	3.03	6313C3	6313C3	4000 lbs.

NOTES:

- DIMENSION V REPRESENTS LENGTH OF STRAIGHT PART OF SHAFT
- MAIN CONDUIT BOX MAY BE ROTATED IN 90° INCREMENTS
- KEY DIMENSIONS EQUAL S x s x 3.00 (MOTOR SUPPLIED WITH KEY).
- MOTOR WEIGHT SHOWN IS MAXIMUM HORSEPOWER IN FRAME.
- THIS DIMENSION EQUALS 2F FOR B447T MOUNTING.
- 400HP/350HP 2 POLE STANDARD PRODUCT USE UNI-DIRECTIONAL FAN. OPPOSITE ROTATION AVAILABLE ONLY BY FAN AND CONNECTION CHANGE.
- 300HP/250HP 2 POLE STANDARD PRODUCT USE BI-DIRECTIONAL FAN. OPPOSITE ROTATION AVAILABLE BY CONNECTION CHANGE.
- FRAME GROUND BOLT STANDARD ON 841 PRODUCT.

CUSTOMER: _____ MOTOR MODEL NO.: _____

P.O. NO.: _____ HP: _____ VOLTAGE: _____ RPM(SYN.): _____ Hz: _____

FRAME SIZE: _____ PRODUCT TYPE: TEFC EQP III SD & 841

COMMENTS: _____

PER: _____ DATE: _____

TAG NO's: _____

<input checked="" type="checkbox"/>	STANDARD (NO AUX. BOXES)
<input type="checkbox"/>	RTD AUX. BOX
<input type="checkbox"/>	SPACE HEATER AUX. BOX
<input type="checkbox"/>	BEARING RTD's

TOSHIBA RESERVES THE RIGHT TO MAKE CHANGES OF TECHNICAL IMPROVEMENT AND THE DATA MAY CHANGE WITHOUT NOTICE PRELIMINARY

DO NOT USE FOR CONSTRUCTION, INSTALLATION, OR APPLICATION PURPOSES UNLESS THE DRAWING IS MARKED AS CERTIFIED CERTIFIED

TOSHIBA

TOSHIBA INTERNATIONAL CORPORATION

TOTALLY-ENCLOSED FAN-COOLED
HORIZONTAL FOOT-MOUNTED
3 PHASE INDUCTION MOTOR
F1 ASSEMBLY

XT SERIES

VISIT OUR WEBSITE AT:
www.toshiba.com/ind

TYPICAL MOTOR PERFORMANCE DATA

Model: 3002XSSC41B

HP	kW	Pole	FL RPM	Frame	Voltage	Hz	Phase	FL Amps
300	224	2	3580	B449TS	575	60	3	260
Enclosure	IP	Ins. Class	S.F.	Duty	NEMA Nom. Eff.	NEMA Design	kVA Code	Ambient (°C)
TEFC	56	F	1.15	CONT	95.8	A		40 C

Load	HP	kW	Amperes	Efficiency (%)	Power Factor (%)
Full Load	300.00	223.7	259	95.8	90.4
¾ Load	225.00	167.8	198	94.7	89.5
½ Load	150.00	111.9	140	92.4	86.2
¼ Load	75.00	55.9	88	85.9	73.6
No Load			59.1		
Locked Rotor			1886		22.8

Torque				Rotor wk ²
Full Load (lb-ft)	Locked Rotor (% FLT)	Pull Up (% FLT)	Break Down (% FLT)	Inertia (lb-ft ²)
440	165	135	255	135.14

Safe Stall Time(s)		Sound Pressure dB(A) @ 1M	Bearings*		Approx. Motor Weight (lbs)
Cold	Hot		DE	NDE	
35	15		6308ZZC3 INS	6308ZZC3 INS	

*Bearings are the only recommended spare part(s).

Motor Options:
Mounting:Footed,Shaft:TS Shaft

Customer	
Customer PO	
Sales Order	
Project #	

Tag:

All characteristics are average expected values.

TOSHIBA INTERNATIONAL CORPORATION · HOUSTON, TEXAS U.S.A.

Engineering	SSuryani	Doc. Written By	D. Suarez	Doc.# / Rev	MPCF-1119 / 0
Engr. Date	4/16/2020	Doc. Approved By	M. Campbell	Doc. Issued	6/8/2011

SPEED TORQUE/CURRENT CURVE

Model: 3002XSSC41B

HP	kW	Pole	FL RPM	Frame	Voltage	Hz	Phase	FL Amps
300	224	2	3580	B449TS	575	60	3	260
Enclosure	IP	Ins. Class	S.F.	Duty	NEMA Nom. Eff.	NEMA Design	kVA Code	Ambient (°C)
TEFC	56	F	1.15	CONT	95.8	A		40 C
Locked Rotor Amps	Rotor wk ² Inertia (lb-ft ²)	Torque						Break Down (%)
		Full Load (lb-ft)	Locked Rotor (%)	Pull Up (%)				
1886	135.14	440	165	135			255	

Design Values

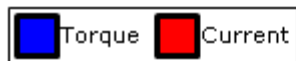
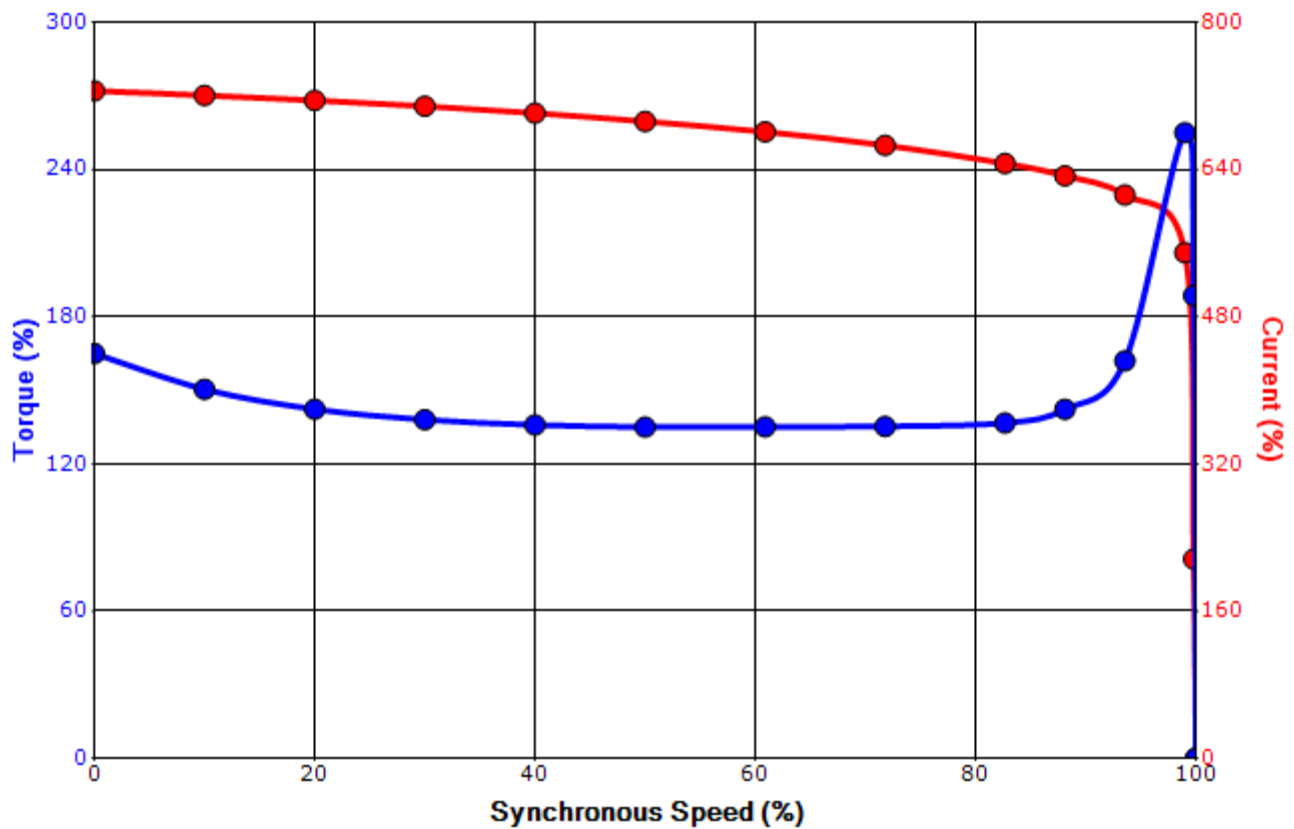

Customer		wk ² Load Inertia (lb-ft ²)	-
Customer PO		Load Type	-
Sales Order		Voltage (%)	100
Project #		Accel. Time	-

Tag:

All characteristics are average expected values.

TOSHIBA INTERNATIONAL CORPORATION · HOUSTON, TEXAS U.S.A.

Engineering	SSuryani	Doc. Written By	D. Suarez	Doc.# / Rev	MPCF-1121 / 0
Engr. Date	4/16/2020	Doc. Approved By	M. Campbell	Doc. Issued	6/8/2011

Motor Connection Diagram 3 Leads - Delta Connection



Switch L1 and L2 to reverse rotation

Each lead may consist of more than one cable.
If multiple cables represent a single lead, each one
of them will be labeled with the appropriate lead number.