

TYPE HS SQUIREL CAGE INDUCTION MOTOR
ENCLOSURE - TOTALLY ENCLOSED FAN COOLED
AND EXPLOSION PROOF
BEARING - ANTI-FRICTION

NOTES

- A- THIS DRAWING IS NOT TO BE REGARDED AS INDICATING EXACT DETAILS OF CONSTRUCTION. IT IS PROPERLY DIMENSIONED FOR ERECTION PURPOSES ONLY.
- B- MOUNTING BOLTS, DOWELS AND COUPLING NOT SUPPLIED BY TOSHIBA UNLESS SPECIFICALLY ORDERED.
- C- WHEN MOUNTING MOTOR, SHIM COMPLETE FOOT PAD AREA.
- D- ANTI-FRICTION BEARINGS MUST BE REGREASED WHILE MOTOR IS RUNNING.
- E- FOR MOUNTING OF MOTOR USE .875-9 THD/INCH HOLD DOWN BOLTS.
- F- NON DRIVE END BEARING INSULATED.

DEVICES

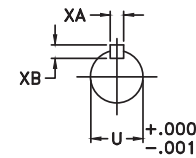
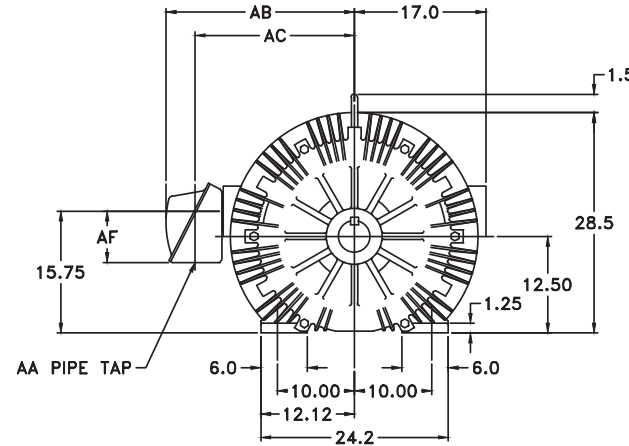
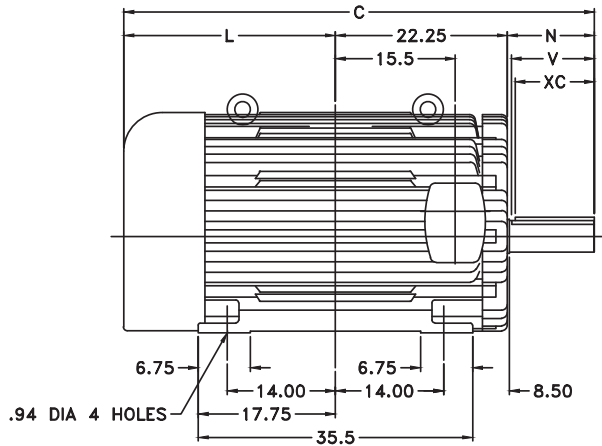

END VIEW OF SHAFT

FRAME SIZE	REAR SHAFT EXTENSION						RECOMMENDED COUPLING BORE		APPROX WEIGHT		
	U	KEY SIZE			N	V	C	L		MIN.	MAX.
D509US	2.375	.625	.625	3.00	4.69	4.25	54.31	27.38	2.3730	2.3740	4000
D509E	2.875	.625	.625	3.75	5.12	4.62	54.75	27.38	2.8730	2.8740	4000
D509G	4.125	.875	.875	10.25	11.25	10.75	60.88	27.38	4000
D509H	5.000	1.250	1.250	11.00	13.25	12.75	62.88	27.38	4000
H509US	2.375	.625	.625	3.00	4.69	4.25	59.81	32.88	2.3730	2.3740	5000
H509E	2.875	.625	.625	3.75	5.12	4.62	60.25	32.88	2.8730	2.8740	5000
H509G	4.125	.875	.875	10.25	11.25	10.75	66.38	32.88	5000
H509H	5.000	1.250	1.250	11.00	13.25	12.75	68.38	32.88	5000

CONDUIT BOX							
FAN COOLED - STANDARD				EXPLOSION PROOF			
AA	AB	AC	AF	AA	AB	AC	AF
3.00	24.38	20.62	6.63	3.00	25.06	20.44	7.00
FAN COOLED - ALTERNATE							
3.50	28.38	22.50	9.38				

THIS DRAWING WAS PREPARED IN ACCORDANCE WITH THE NORMAL AND ACCEPTED STANDARDS WITHIN THE ELECTRICAL INDUSTRY FOR THE PURPOSE OF OBTAINING CUSTOMER APPROVAL. AS PART OF THE MANUFACTURING OR PRODUCTION PROCESS, ANY USE OR COMPARISON OF THIS DRAWING BY THE CUSTOMER CONCERNING THE DRAWING SHALL BE THE SOLE RESPONSIBILITY OF THE CUSTOMER.

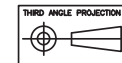

THESE DIMENSIONS REFER TO THE POSITION OF THE CENTER OF GRAVITY OF THE MOTOR. THE MOTOR SHALL BE MOUNTED ON ISOLATORS, AND NO PORTION OF THE MOTOR SHALL BE SUPPORTED OR USED WITHOUT THE EXPRESS PERMISSION OF THE COMPANY.

TOSHIBA INDUSTRIAL PRODUCTS CANADA

TOSHIBA

TITLE TYPE HS MOTOR FRAME D509/H509
OUTLINE - TEFC/TEXP ENCLOSURE

DESIGNED BY	SCALE: N.T.S.	SHEET: 1	OF 1
CHECKED BY	DATE: 1/28/99	APP'VD BY	
DESIGNED BY	N.WEST	APP'VD BY	
CHECKED BY		APP'VD BY	

E10D118

STANDARD
REVISIONS
ISSUE 1



Issued Date

Transmit #

Issued By

Issued Rev

TYPICAL MOTOR PERFORMANCE DATA

Model: 3003XPAL11F-C

HP	kW	Pole	FL RPM	Frame	Voltage	Hz	Phase	FL Amps
300 hp	224 kW	2	3569 rpm	H509US	4000 V	60	3	36.6 A
Enclosure	IP	Ins. Class	S.F.	Duty	NEMA Nom. Eff.	NEMA Design	kVA Code	Ambient (°C)
TEXP	55	F	1.15	Cont.	93.8	B	F	40

Load	HP	kW	Amperes	Efficiency (%)	Power Factor (%)
Full Load	300	224	36.6	93.8	94.3
¾ Load	225	168	27.7	93.2	93.8
½ Load	150	112	19.3	91.7	91.3
¼ Load	75	56			
No Load			6.8		14.5
Locked Rotor			234.8		19.3

Torque				Rotor wk ² Inertia (lb-ft ²)
Full Load (lb-ft)	Locked Rotor (% FLT)	Pull Up (% FLT)	Break Down (% FLT)	
443	84	84	258	101

Safe Stall Time(s)		Sound Pressure dB(A) @ 1M	Bearings*		Approx. Motor Weight (lbs)
Cold	Hot		DE	NDE	
24	19	-	6313Z-C3	6313Z-C3	5000

*Bearings are the only recommended spare part(s).

Motor Options:

Customer	
Customer PO	
Sales Order	
Project #	

Tag:

All characteristics are average expected values.

TOSHIBA INTERNATIONAL CORPORATION · HOUSTON, TEXAS U.S.A.

Engineering		Doc. Written By		Doc.# / Rev	
Engr. Date		Doc. Approved By		Doc. Issued	



Issued Date

Transmit #

Issued By

Issued Rev

NAMEPLATE DATA

Model: 3003XPAL11F-C

HP	kW	Pole	FL RPM	Frame	Voltage	Hz	Phase	FL Amps
300	223.707	2	3569	H509US	4000	60	3	36.63
Enclosure	IP	Ins. Class	S.F.	Duty	NEMA Nom. Eff.	NEMA Design	kVA Code	Ambient (°C)
TEXP	55	F	1.15	Cont.	93.8	B	F	40

Type: HSB

Form:

Drive End Bearing: 6313Z-C3

Non-Drive End Bearing: 6313Z-C3

Power Factor: 94.3

Max Safe RPM:

Comments 1:

Comments 2:

Comments 3:

Comments 4:

Customer

Customer PO

Sales Order

Project #

Tag:

All characteristics are average expected values.

TOSHIBA INTERNATIONAL CORPORATION · HOUSTON, TEXAS U.S.A.

Engineering	Doc. Written By	D. Suarez	Doc.# / Rev	MPCF-1120 / 0
Engr. Date	Doc. Approved By	M. Campbell	Doc. Issued	6/8/2011



Issued Date		Transmit #	
Issued By		Issued Rev	

SPEED TORQUE/CURRENT CURVE

Model: 3003XPAL11F-C

HP	kW	Pole	FL RPM	Frame	Voltage	Hz	Phase	FL Amps
300	223.707	2	3569	H509US	4000	60	3	36.63
Enclosure	IP	Ins. Class	S.F.	Duty	NEMA Nom. Eff.	NEMA Design	kVA Code	Ambient (°C)
TEXP	55	F	1.15	Cont.	93.8	B	F	40
Locked Rotor Amps	Rotor wk ² Inertia (lb-ft ²)	Torque				Pull Up (%)	Break Down (%)	
		Full Load (lb-ft)	Locked Rotor (%)					
234.75	101	443.01	84.29606555		84.29606555		258.427101	

Design Values

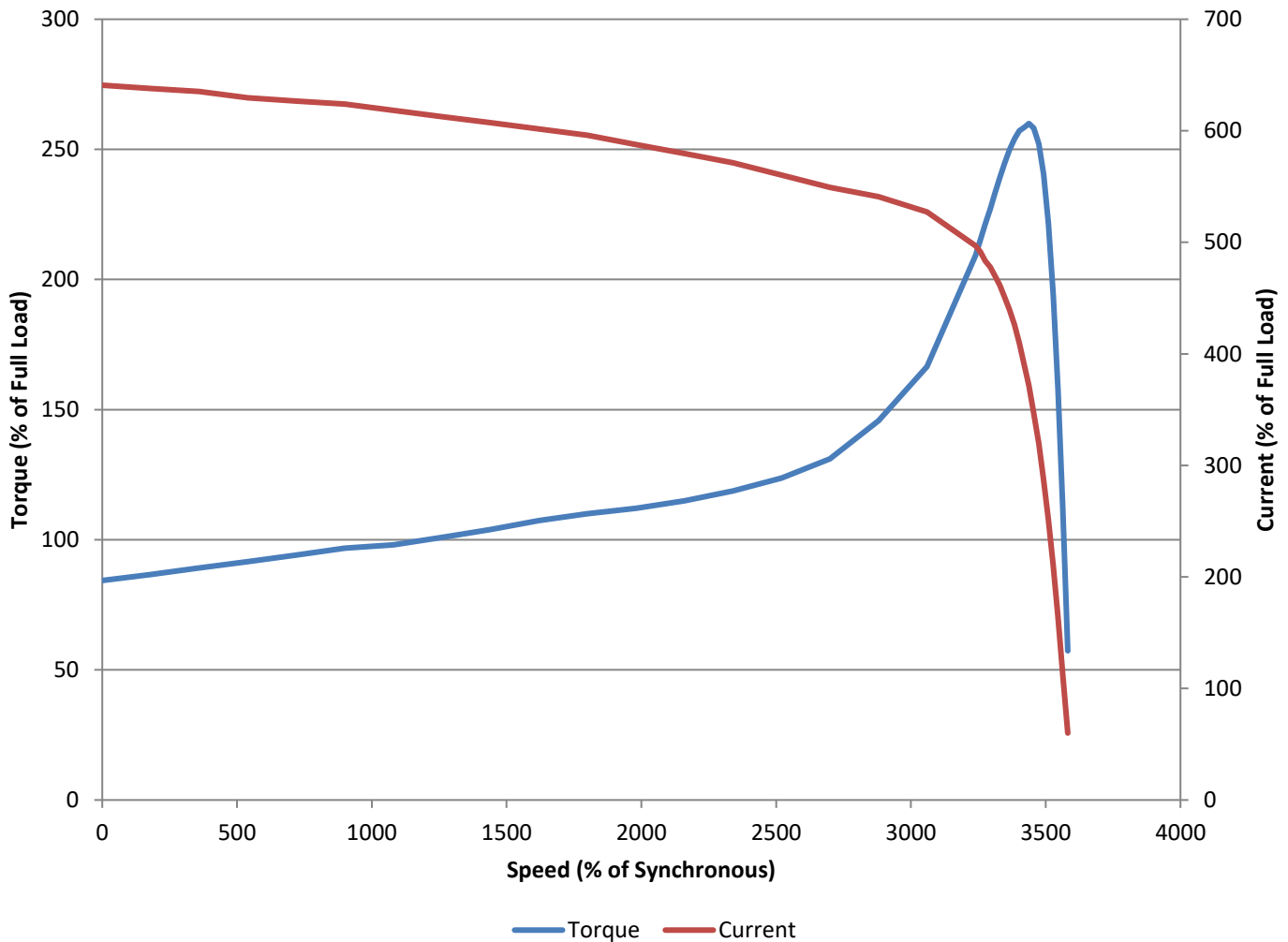

Customer		wk ² Load Inertia (lb-ft ²)		
Customer PO			Load Type	
Sales Order			Voltage (%)	100
Project #			Accel. Time	

Tag:

All characteristics are average expected values.

TOSHIBA INTERNATIONAL CORPORATION · HOUSTON, TEXAS U.S.A.

Engineering		Doc. Written By	D. Suarez	Doc.# / Rev	MPCF-1121/0
Engr. Date		Doc. Approved By	M. Campbell	Doc. Issued	6/8/2011



Issued Date

Transmit #

Issued By

Issued Rev

SPARE PARTS LIST*

Model: 3003XPAL11F-C

HP	kW	Pole	FL RPM	Frame	Voltage	Hz	Phase	FL Amps
300	223.707	2	3569	H509US	4000	60	3	36.63
Enclosure	IP	Ins. Class	S.F.	Duty	NEMA Nom. Eff.	NEMA Design	kVA Code	Ambient (°C)
TEXP	55	F	1.15	Cont.	93.8	B	F	40

Bearings DE 6313Z-C3

Bearings NDE 6313Z-C3

*Bearings are the only recommended spare part(s).

Other than the grease used for regreasable bearings and the oil used for oil-lubricated bearings, Toshiba advises that there are no "use" parts. The only insurance spares that Toshiba suggests for these squirrel-cage induction motors are industry-standard and commercially available off-the-shelf bearings as noted above.

Motor components such as terminal boxes, fan covers and other machined parts are available on special request. In these cases, please advise our order entry department of the model and serial numbers found on the motor nameplate and a description of the needed components. With this information they will be able to furnish the current part number, price and availability.

Note: Our internal part numbers are subject to change without notice and are not published.

Customer	
Customer PO	
Sales Order	
Project #	

Tag:

All characteristics are average expected values.

TOSHIBA INTERNATIONAL CORPORATION · HOUSTON, TEXAS U.S.A.

Engineering		Doc. Written By	D. Suarez	Doc.# / Rev	MPCF-1125 / 0
Engr. Date		Doc. Approved By	M. Campbell	Doc. Issued	6/8/2011