

NOTE:
LIFTING RINGS
(2) 180° APART
FOR MOTOR
LIFTING ONLY

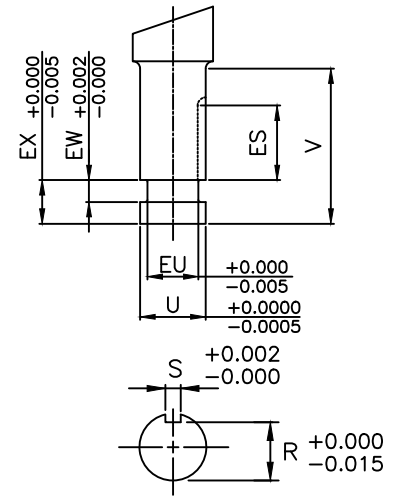
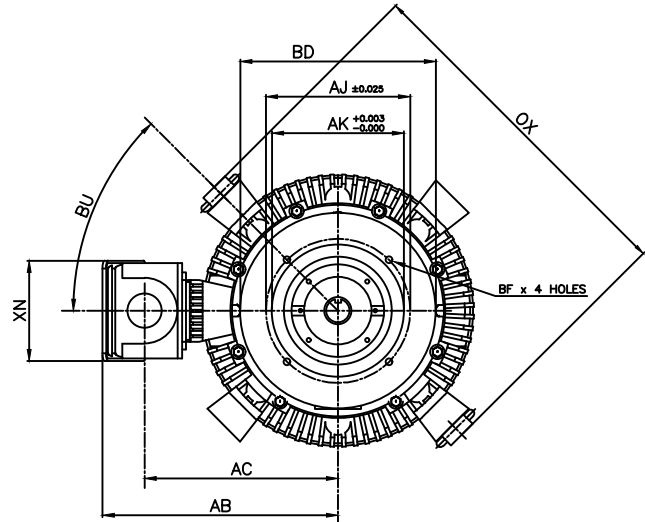
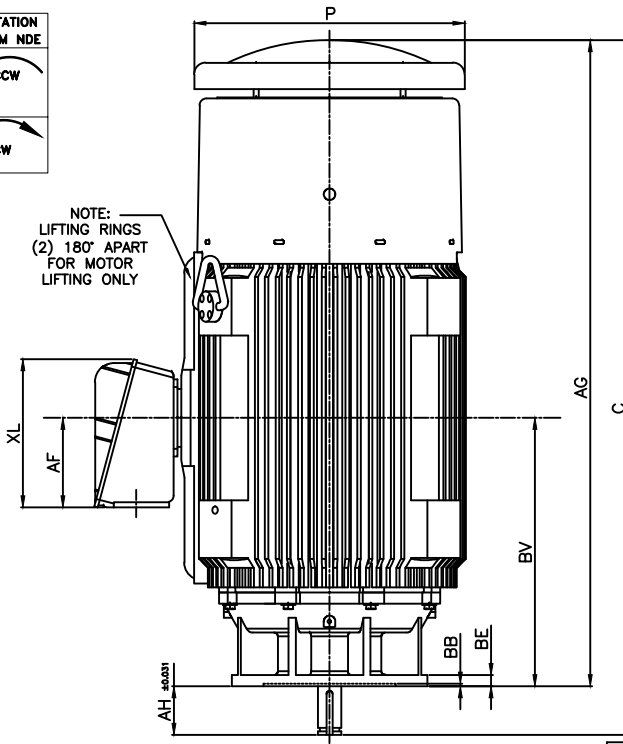

- NOTES:
1. DIMENSION V REPRESENTS LENGTH OF STRAIGHT PART OF SHAFT
 2. MAIN CONDUIT BOX MAY BE ROTATED IN 90° INCREMENTS
 3. KEY DIMENSIONS EQUAL S x S x ES (MOTOR SUPPLIED WITH KEY)
 4. MOTOR WEIGHT SHOWN IS MAXIMUM HORSEPOWER IN FRAME
 5. STANDARD PRODUCT USE BI-DIRECTIONAL FAN. OPPOSITE ROTATION AVAILABLE ONLY BY CONNECTION CHANGE

UNITS: INCHES

FRAME SIZE	MOTOR DIMENSIONS				P-FLANGE DIMENSIONS							
	AG	C	P	OX	BU	BB	BE	BF	BD	BV	AK	AJ
N449HP20	66.1	71.1	27.7	35.9	45°	0.25	1.0	0.69	20.0	27.5	13.50	14.75
N449HP24	66.1	71.1	27.7	35.9	45°	0.25	1.0	0.69	24.0	27.5	13.50	14.75
N449LP20	66.1	71.1	27.7	35.9	45°	0.25	1.0	0.69	20.0	27.5	13.50	14.75
N449LP24	66.1	71.1	27.7	35.9	45°	0.25	1.0	0.69	24.0	27.5	13.50	14.75

POLE SPEED	HORSE POWER	SHAFT EXTENSION DIMENSIONS									
		AH	EU	U	V	R	S	ES	EW	EX	
2	250~350	4.50	1.75	2.125	4.50	1.845	0.500	3.03	0.375	0.75	
	350~300	4.50	1.75	2.125	4.50	1.845	0.500	3.03	0.375	0.75	
4	350	5.00	2.00	2.375	5.00	2.021	0.625	3.53	0.375	0.75	
	200	4.50	1.75	2.125	4.50	1.845	0.500	3.03	0.375	0.75	
6	250	5.00	2.00	2.375	5.00	2.021	0.625	3.53	0.375	0.75	
	300~350	5.00	2.25	2.625	5.00	2.275	0.625	3.53	0.375	0.75	
8	150	5.00	2.00	2.375	5.00	2.021	0.625	3.53	0.375	0.75	
	200~250	5.00	2.25	2.625	5.00	2.275	0.625	3.53	0.375	0.75	

CONDUIT BOX DIMENSIONS						MAXIMUM WEIGHT
AA/NPT	AB	AC	AF	XL	XN	
3.00	24.1	19.8	9.2	15.2	10.3	3800 LBS

FRAME SIZE	BEARINGS	
	LS	OS
2 POLE HP	6313C3	6315C3
2 POLE LP	6313C3	7315BEGAM x 2
4~8 POLE HP	6318C3	6315C3
4~8 POLE LP	6318C3	7315BEGAM x 2

CUSTOMER: _____ MOTOR MODEL NO.: _____ TAG NO's.: _____

P.O. NO.: _____ HP: _____ VOLTAGE: _____ RPM(SYN.): _____ Hz: _____

FRAME SIZE: _____ PRODUCT TYPE: VERTICAL SOLID SHAFT ROUND BODY P-FLANGE

COMMENTS: _____

PER: _____ DATE: _____

STANDARD (NO AUX. BOXES)

RTD AUX. BOX

SPACE HEATER AUX. BOX

BEARING RTD's

TOSHIBA RESERVES THE RIGHT TO MAKE CHANGES OF TECHNICAL IMPROVEMENT AND THE DATA MAY CHANGE WITHOUT NOTICE PRELIMINARY

DO NOT USE FOR CONSTRUCTION, INSTALLATION, OR APPLICATION PURPOSES UNLESS THE DRAWING IS MARKED AS CERTIFIED CERTIFIED

TOSHIBA
TOSHIBA INTERNATIONAL CORPORATION

TOTALLY-ENCLOSED FAN-COOLED
VERTICAL SOLID SHAFT ROUND BODY P-FLANGE
3 PHASE INDUCTION MOTOR
F1 ASSEMBLY

XT SERIES
VISIT OUR WEBSITE AT:
www.toshiba.com/ind

TYPICAL MOTOR PERFORMANCE DATA

Model: 3004FTVB3SX-A

HP	kW	Pole	FL RPM	Frame	Voltage	Hz	Phase	FL Amps
300	224	4	1780	N449LP20	460	60	3	328
Enclosure	IP	Ins. Class	S.F.	Duty	NEMA Nom. Eff.	NEMA Design	kVA Code	Ambient (°C)
TEFC	54	F	1.15	CONT	95.4	B		40 C

Load	HP	kW	Amperes	Efficiency (%)	Power Factor (%)
Full Load	300.00	223.7	328	95.6	89.6
¾ Load	225.00	167.8	250	95.1	89.2
½ Load	150.00	111.9	174	93.7	86.4
¼ Load	75.00	55.9	106	90.0	73.4
No Load			69.0		4.9
Locked Rotor			2178		27.2

Torque				Rotor wk ² Inertia (lb-ft ²)
Full Load (lb-ft)	Locked Rotor (% FLT)	Pull Up (% FLT)	Break Down (% FLT)	
885	185	180	230	158.12

Safe Stall Time(s)		Sound Pressure dB(A) @ 1M	Bearings*		Approx. Motor Weight (lbs)
Cold	Hot		DE	NDE	
22	11	-	6318C3	7315B	3600

*Bearings are the only recommended spare part(s).

Motor Options:
Product Family:EQPIII Vertical Medium Thrust
Mounting:20 P-Base (440 Frame),Shaft:LP Solid Shaft Medium Thrust

Customer	
Customer PO	
Sales Order	
Project #	

Tag:

All characteristics are average expected values.

TOSHIBA INTERNATIONAL CORPORATION · HOUSTON, TEXAS U.S.A.

Engineering	jaustin	Doc. Written By	D. Suarez	Doc.# / Rev	MPCF-1119 / 0
Engr. Date	6/27/2014	Doc. Approved By	M. Campbell	Doc. Issued	6/8/2011

SPEED TORQUE/CURRENT CURVE

Model: 3004FTVB3SX-A

HP	kW	Pole	FL RPM	Frame	Voltage	Hz	Phase	FL Amps
300	224	4	1780	N449LP20	460	60	3	328
Enclosure	IP	Ins. Class	S.F.	Duty	NEMA Nom. Eff.	NEMA Design	kVA Code	Ambient (°C)
TEFC	54	F	1.15	CONT	95.4	B		40 C
Locked Rotor Amps	Rotor wk ² Inertia (lb-ft ²)	Torque						Break Down (%)
		Full Load (lb-ft)	Locked Rotor (%)	Pull Up (%)				
2178	158.12	885	185	180			230	

Design Values

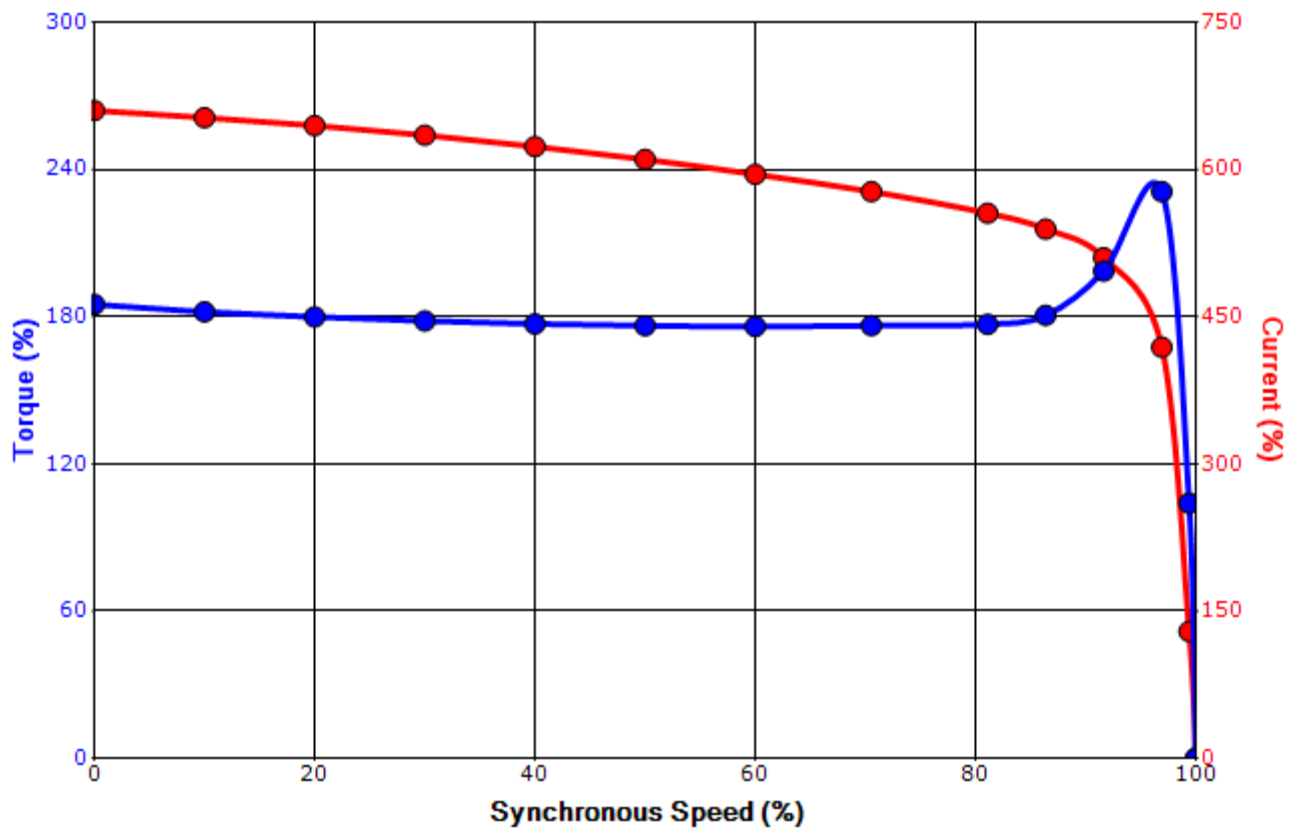

Customer		wk ² Load Inertia (lb-ft ²)	-
Customer PO		Load Type	-
Sales Order		Voltage (%)	100
Project #		Accel. Time	-

Tag:

All characteristics are average expected values.

TOSHIBA INTERNATIONAL CORPORATION · HOUSTON, TEXAS U.S.A.

Engineering	jaustin	Doc. Written By	D. Suarez	Doc.# / Rev	MPCF-1121 / 0
Engr. Date	6/27/2014	Doc. Approved By	M. Campbell	Doc. Issued	6/8/2011