

TECHNICAL INFORMATION

1. BEARING LUBRICATION DE: TURBINE OIL ISO VG32
ODE: TURBINE OIL ISO VG32
2. BEARING TYPE DE: M9-90-INS
ODE: M9-90-INS
3. WINDING TEMP. DETECTORS
NUMBER AND TYPE: 6xRTD(Pt0°C-100ohm)
LOCATION: IN STATOR SLOT
4. BEARING TEMP. DETECTORS
NUMBER AND TYPE: _____
5. SPACE HEATER 1 PHASE
VOLTS: 120 WATTS: 400
6. ROTATION: CCW VIEWED FROM NON DRIVE END
THIS MOTOR IS UNI DIRECTIONAL
7. MOTOR PAINT COLOR: _____
8. APPROX. WEIGHT: 5100 Lbs
9. ACCESORIES: _____

DRAWING LIST

MAIN TERMINAL BOX					
AUX TERMINAL BOX FOR					
SPACE HEATER					
R.T.D.		1	CHANGE AUX BOX DIM FROM 12.3	HL	3/16/20
THERMISTOR					
		0	FIRST ISSUE	TZ	3/8/05
PRODUCTION #		NO.	REVISION	BY	DATE

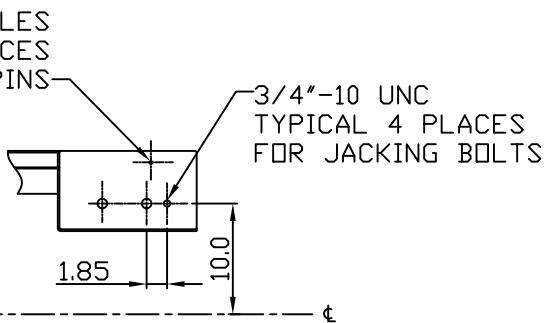

MOTOR OUTLINE FOR THREE PHASE INDUCTION MOTOR						
CUSTOMER NAME			P.O. NO.		MOTOR TAG NO.	
OUTPUT HP	POLE	VOLTAGE	FREQUENCY	FULL LOAD SPEED	TOSHIBA MODEL NO.	
	2	2300/4000 V	60 Hz	(min ⁻¹)		
TYPE	FORM	INS. CLASS	RATING	FRAME	S.F.	ENCLOSURE
		F	CONT.	5011/12	1.15	WP-II
TOSHIBA INTERNATIONAL CORPORATION HOUSTON, TEXAS U.S.A.						
3rd ANGLE PROJ.	PREPARED BY:	DATE:	CHECKED BY:	DATE:	DRAWING NO.:	REV.
	T. ZIEBRO	3/8/05			MDSL0087-07	1

TYPICAL MOTOR PERFORMANCE DATA

Model: 4003WTQK11F-A

HP	kW	Pole	FL RPM	Frame	Voltage	Hz	Phase	FL Amps
400	298	2	3555	5012USS	4000	60	3	53
Enclosure	IP	Ins. Class	S.F.	Duty	NEMA Nom. Eff.	NEMA Design	kVA Code	Ambient (°C)
WP-II	24	F	1.15	CONT	93.5	-		40 C

Load	HP	kW	Amperes	Efficiency (%)	Power Factor (%)
Full Load	400.00	298.3	53	93.5	86.4
¾ Load	300.00	223.7	41	93.1	83.4
½ Load	200.00	149.1	30	91.9	75.9
¼ Load	100.00	74.6	22	87.5	55.4
No Load			14.0		7.1
Locked Rotor			299		23.3

Torque				Rotor wk ²
Full Load (lb-ft)	Locked Rotor (% FLT)	Pull Up (% FLT)	Break Down (% FLT)	Inertia (lb-ft ²)
591	125	65	250	81.10

Safe Stall Time(s)		Sound Pressure dB(A) @ 1M	Bearings*		Approx. Motor Weight (lbs)
Cold	Hot		DE	NDE	
15	10		M9-90 INS	M9-90 INS	0

*Bearings are the only recommended spare part(s).

Motor Options:
Product Family:WP-II
Mounting:Footed,Shaft:USS Shaft

Customer	
Customer PO	
Sales Order	
Project #	

Tag:

All characteristics are average expected values.

TOSHIBA INTERNATIONAL CORPORATION · HOUSTON, TEXAS U.S.A.

Engineering	bmmamen	Doc. Written By	D. Suarez	Doc.# / Rev	MPCF-1119 / 0
Engr. Date	7/22/2014	Doc. Approved By	M. Campbell	Doc. Issued	6/8/2011

SPEED TORQUE/CURRENT CURVE

Model: 4003WTQK11F-A

HP	kW	Pole	FL RPM	Frame	Voltage	Hz	Phase	FL Amps
400	298	2	3555	5012USS	4000	60	3	53
Enclosure	IP	Ins. Class	S.F.	Duty	NEMA Nom. Eff.	NEMA Design	kVA Code	Ambient (°C)
WP-II	24	F	1.15	CONT	93.5	-		40 C
Locked Rotor Amps	Rotor wk ² Inertia (lb-ft ²)	Torque						Break Down (%)
		Full Load (lb-ft)	Locked Rotor (%)	Pull Up (%)				
299	81.10	591	125	65			250	

Design Values

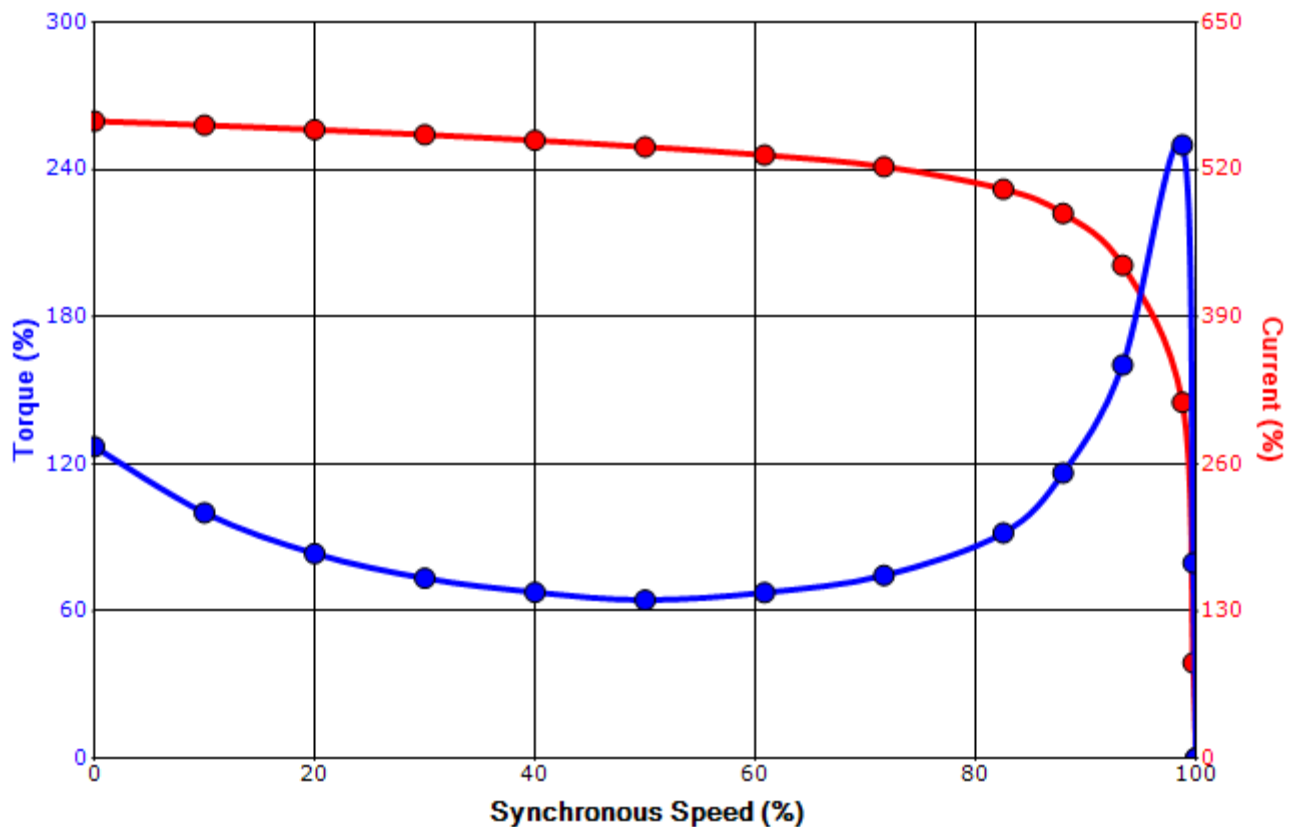

Customer		wk ² Load Inertia (lb-ft ²)	-
Customer PO		Load Type	-
Sales Order		Voltage (%)	100
Project #		Accel. Time	-

Tag:

All characteristics are average expected values.