

**TECHNICAL INFORMATION**

1. BEARING LUBRICATION DE: MOBIL POLYREX EM  
ODE: MOBIL POLYREX EM
2. BEARING TYPE DE: 6321C3  
ODE: 6321C3 (INSULATED)
3. WINDING TEMP. DETECTORS  
NUMBER AND TYPE: 6xRTD(Pt0°C-100ohm)  
LOCATION: IN STATOR SLOT
4. BEARING TEMP. DETECTORS  
NUMBER AND TYPE: N/A
5. SPACE HEATER 1 PHASE  
VOLTS: 120 WATTS: 400
6. ROTATION: CCW VIEWED FROM NON DRIVE END  
THIS MOTOR IS BI DIRECTIONAL
7. MOTOR PAINT COLOR: GRAY
8. APPROX. WEIGHT: 5000 Lbs.
9. ACCESORIES:

DRAWING LIST		NO.	REVISION	BY	DATE
MAIN TERMINAL BOX 130-7622-55					
AUX TERMINAL BOX FOR SPACE HEATER 130-7520-50 R.T.D. 130-7522-51 THERMISTOR -					
PRODUCTION #	-	0	FIRST ISSUE	MH	012904
UNITS:	INCHES				

MOTOR OUTLINE FOR THREE PHASE INDUCTION MOTOR						
CUSTOMER NAME			P.O. NO.		MOTOR TAG NO.	
OUTPUT HP	POLE	VOLTAGE V	FREQUENCY Hz	FULL LOAD SPEED (min <sup>-1</sup> )	TOSHIBA MODEL NO.	
TYPE	FORM	INS. CLASS F	RATING CONT.	FRAME 5011/12US	S.F.	ENCLOSURE WP-I
<b>TOSHIBA INTERNATIONAL CORPORATION HOUSTON, TEXAS U.S.A.</b>						
3rd ANGLE PROJ.	PREPARED BY: M.HO	DATE: 012904	CHECKED BY: D. HENSLEY	DATE: 012904	DRAWING NO.: MDSL0086-06	REV. 1

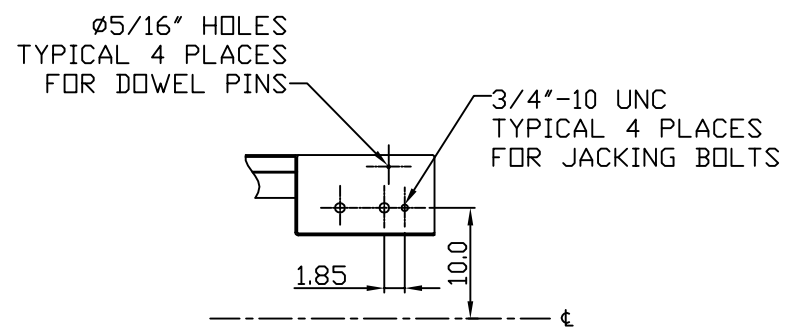

**TYPICAL MOTOR PERFORMANCE DATA**

Model: 4506WPAK11E-C

HP	kW	Pole	FL RPM	Frame	Voltage	Hz	Phase	FL Amps
450	336	6	1180	5012US	4000	60	3	66
Enclosure	IP	Ins. Class	S.F.	Duty	NEMA Nom. Eff.	NEMA Design	kVA Code	Ambient (°C)
WP-I	23	F	1.15	CONT	93	-	H	40 C

Load	HP	kW	Amperes	Efficiency (%)	Power Factor (%)
Full Load	450	335.6	65.0	93.5	79.7
¾ Load	337.50	251.7	52.0	93.3	74.9
½ Load	225.00	167.8	40.7	92.3	64.5
¼ Load	112.50	83.9	32.4	88.5	42.2
No Load			25.7		3.3
Locked Rotor			452.00		27.9

Torque				Rotor wk <sup>2</sup> Inertia (lb-ft <sup>2</sup> )
Full Load (lb-ft)	Locked Rotor (% FLT)	Pull Up (% FLT)	Break Down (% FLT)	
2005	170	105	305	218.85

Safe Stall Time(s)		Sound Pressure dB(A) @ 1M	Bearings*		Approx. Motor Weight (lbs)
Cold	Hot		DE	NDE	
24.5	14.7	-	6321C3	6321C3 INS	

\*Bearings are the only recommended spare part(s).

**Motor Options:**  
Product Family:ODP & WP-I  
Mounting:Footed,Shaft:US Shaft

Customer	
Customer PO	
Sales Order	
Project #	

Tag:

All characteristics are average expected values.

**TOSHIBA INTERNATIONAL CORPORATION · HOUSTON, TEXAS U.S.A.**

Engineering	bmammen	Doc. Written By	D. Suarez	Doc.# / Rev	MPCF-1119 / 0
Engr. Date	8/18/2014	Doc. Approved By	M. Campbell	Doc. Issued	6/8/2011

**SPEED TORQUE/CURRENT CURVE**

Model: 4506WPAK11E-C

HP	kW	Pole	FL RPM	Frame	Voltage	Hz	Phase	FL Amps
450	336	6	1180	5012US	4000	60	3	66
Enclosure	IP	Ins. Class	S.F.	Duty	NEMA Nom. Eff.	NEMA Design	kVA Code	Ambient (°C)
WP-I	23	F	1.15	CONT	93	-	H	40 C
Locked Rotor Amps	Rotor wk <sup>2</sup> Inertia (lb-ft <sup>2</sup> )	Torque						Break Down (%)
		Full Load (lb-ft)	Locked Rotor (%)	Pull Up (%)				
452.00	218.85	2005	170	105			305	

**Design Values**

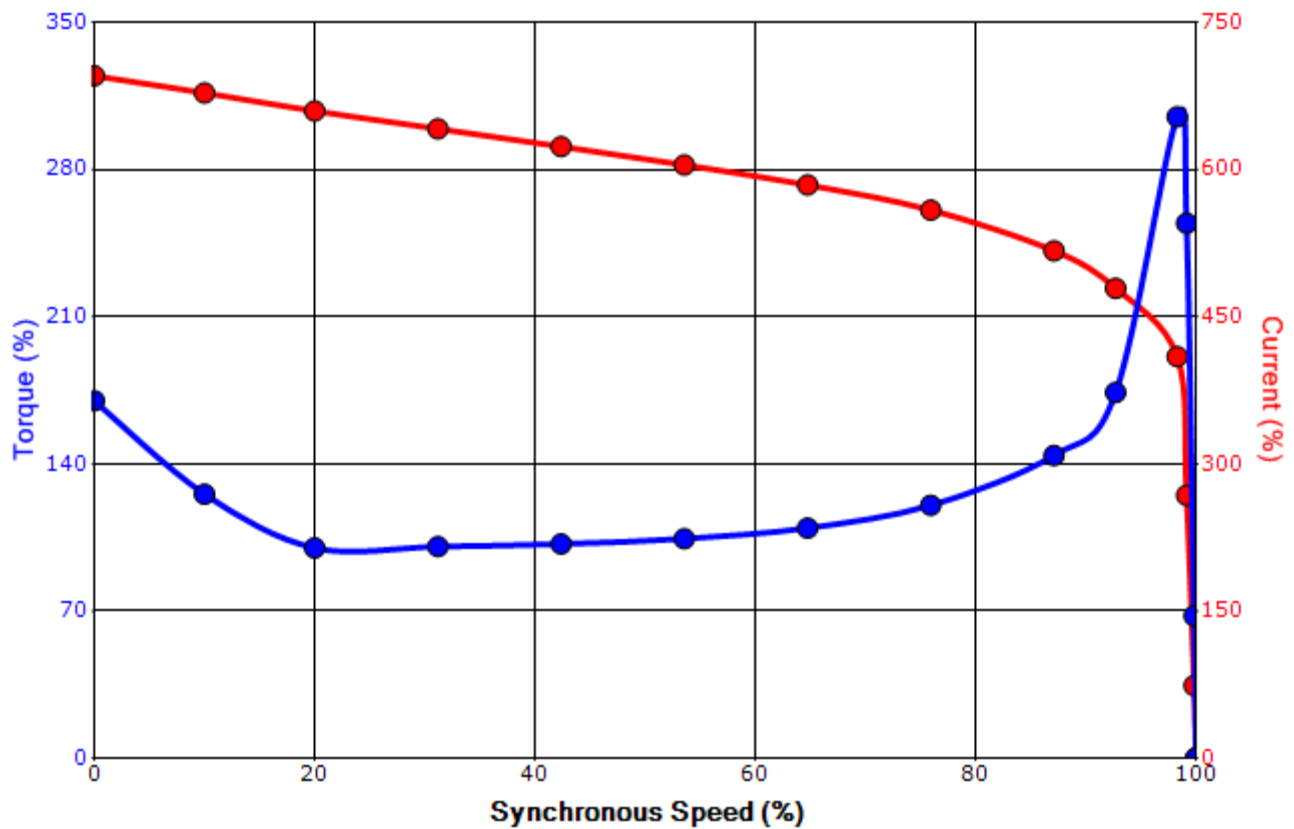

Customer		wk <sup>2</sup> Load Inertia (lb-ft <sup>2</sup> )	-
Customer PO		Load Type	-
Sales Order		Voltage (%)	100
Project #		Accel. Time	-

Tag:

All characteristics are average expected values.

**TOSHIBA INTERNATIONAL CORPORATION · HOUSTON, TEXAS U.S.A.**

Engineering	bmammen	Doc. Written By	D. Suarez	Doc.# / Rev	MPCF-1121 / 0
Engr. Date	8/18/2014	Doc. Approved By	M. Campbell	Doc. Issued	6/8/2011