

TECHNICAL INFORMATION

1. BEARING LUBRICATION DE: MOBIL POLYREX EM
ODE: MOBIL POLYREX EM
2. BEARING TYPE DE: 6315C3
ODE: 6315C3 INSULATED
3. WINDING TEMP. DETECTORS
NUMBER AND TYPE: 6xRTD(Pt0°C-100ohm)
LOCATION: IN STATOR SLOT
4. BEARING TEMP. DETECTORS
NUMBER AND TYPE: N/A
5. SPACE HEATER 1 PHASE
VOLTS: 120 WATTS: 400
6. ROTATION: CCW VIEWED FROM NON DRIVE END
THIS MOTOR IS UNI DIRECTIONAL
7. MOTOR PAINT COLOR: GRAY
8. APPROX. WEIGHT: 5000 Lbs.
9. ACCESORIES:

DRAWING LIST	
MAIN TERMINAL BOX 130-7622-55	
AUX TERMINAL BOX FOR SPACE HEATER 130-7520-50	2
R.T.D. 130-7522-51	1
THERMISTOR -	
PRODUCTION # -	0
UNITS: INCHES	

NO.	REVISION	BY	DATE
2	CHANGE AUX BOX DIM FROM 12.3	HL	3/16/20
1	GRS FROM SRI	RWS	1/2/14
0	FIRST ISSUE	MH	012904

MOTOR OUTLINE FOR THREE PHASE INDUCTION MOTOR						
CUSTOMER NAME			P.O. NO.		MOTOR TAG NO.	
OUTPUT HP	POLE	VOLTAGE V	FREQUENCY Hz	FULL LOAD SPEED (min ⁻¹)	TOSHIBA MODEL NO.	
TYPE	FORM	INS. CLASS F	RATING CONT.	FRAME 5011/12USS	S.F.	ENCLOSURE WP-II
TOSHIBA INTERNATIONAL CORPORATION HOUSTON, TEXAS U.S.A.						
3rd ANGLE PROJ.	PREPARED BY: M.HO	DATE: 012904	CHECKED BY: D. HENSLEY	DATE: 012904	DRAWING NO.: MDSL0087-05	REV. 2

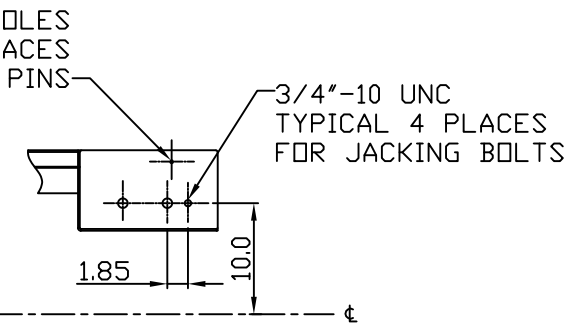

TYPICAL MOTOR PERFORMANCE DATA

Model: 5003WTAK11F-C

HP	kW	Pole	FL RPM	Frame	Voltage	Hz	Phase	FL Amps
500	373	2	3575	5012USS	4000	60	3	66
Enclosure	IP	Ins. Class	S.F.	Duty	NEMA Nom. Eff.	NEMA Design	kVA Code	Ambient (°C)
WP-II	24	F	1.15	CONT	93.3	B		40 C

Load	HP	kW	Amperes	Efficiency (%)	Power Factor (%)
Full Load	500.00	372.9	65	93.6	87.3
¾ Load	375.00	279.6	51	93.3	84.9
½ Load	250.00	186.4	37	92.2	78.4
¼ Load	125.00	93.2	25	88.3	58.8
No Load			15.7		9.4
Locked Rotor			345		17.7

Torque				Rotor wk ² Inertia (lb-ft ²)
Full Load (lb-ft)	Locked Rotor (% FLT)	Pull Up (% FLT)	Break Down (% FLT)	
735	80	90	245	92.35

Safe Stall Time(s)		Sound Pressure dB(A) @ 1M	Bearings*		Approx. Motor Weight (lbs)
Cold	Hot		DE	NDE	
35	15		6315C3	6315C3 INS	5000

*Bearings are the only recommended spare part(s).

Motor Options:
Product Family:WP-II
Mounting:Footed,Shaft:USS Shaft

Customer	
Customer PO	
Sales Order	
Project #	

Tag:

All characteristics are average expected values.

TOSHIBA INTERNATIONAL CORPORATION · HOUSTON, TEXAS U.S.A.

Engineering	bmmamen	Doc. Written By	D. Suarez	Doc.# / Rev	MPCF-1119 / 0
Engr. Date	7/14/2014	Doc. Approved By	M. Campbell	Doc. Issued	6/8/2011

SPEED TORQUE/CURRENT CURVE

Model: 5003WTAK11F-C

HP	kW	Pole	FL RPM	Frame	Voltage	Hz	Phase	FL Amps
500	373	2	3575	5012USS	4000	60	3	66
Enclosure	IP	Ins. Class	S.F.	Duty	NEMA Nom. Eff.	NEMA Design	kVA Code	Ambient (°C)
WP-II	24	F	1.15	CONT	93.3	B		40 C
Locked Rotor Amps	Rotor wk ² Inertia (lb-ft ²)	Torque						Break Down (%)
		Full Load (lb-ft)	Locked Rotor (%)	Pull Up (%)				
345	92.35	735	80	90			245	

Design Values

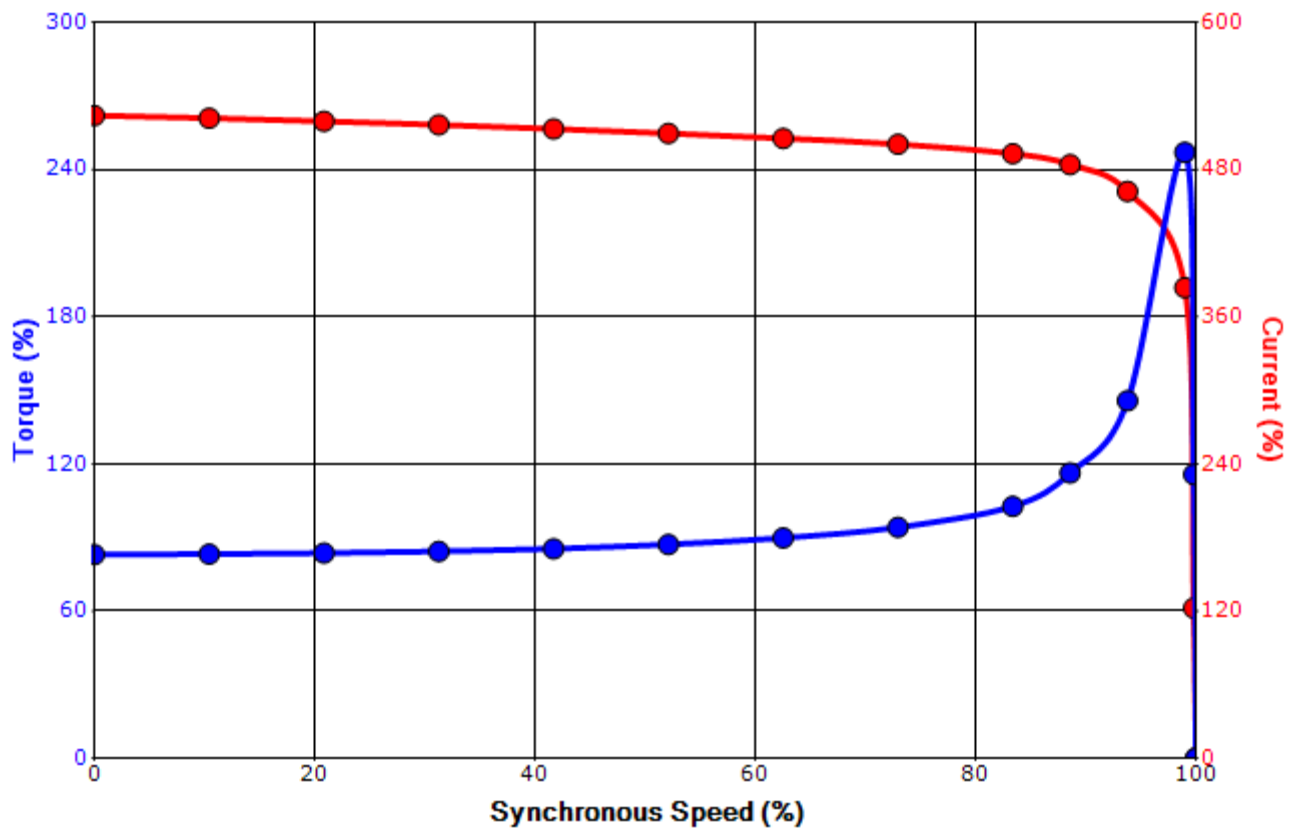

Customer		wk ² Load Inertia (lb-ft ²)	-
Customer PO		Load Type	-
Sales Order		Voltage (%)	100
Project #		Accel. Time	-

Tag:

All characteristics are average expected values.

TOSHIBA INTERNATIONAL CORPORATION · HOUSTON, TEXAS U.S.A.

Engineering	bmammen	Doc. Written By	D. Suarez	Doc.# / Rev	MPCF-1121 / 0
Engr. Date	7/14/2014	Doc. Approved By	M. Campbell	Doc. Issued	6/8/2011