

Ø3/4"-10 UNC 4 PLACES FOR JACKING BOLTS

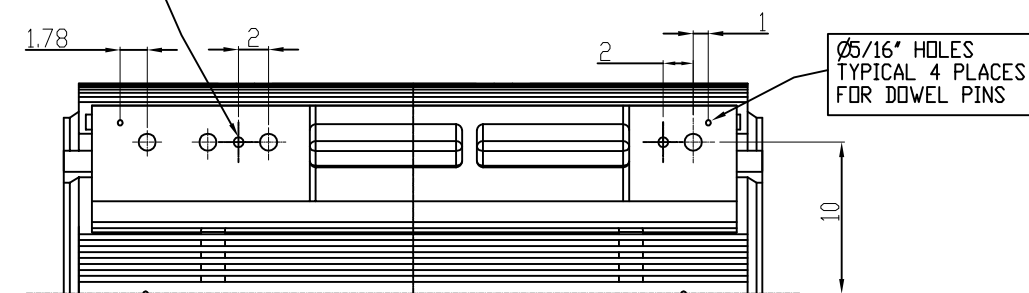

UNITS: INCHES

TECHNICAL INFORMATION

1. BEARING LUBRICATION DE: TURBINE OIL ISO VG32
ODE: TURBINE OIL ISO VG32
2. BEARING TYPE DE: M9-90 INS
ODE: M9-90 INS
3. WINDING TEMP. DETECTORS
NUMBER AND TYPE: 6xRTD(Pt0°C-100ohm)
LOCATION: IN STATOR SLOT
4. BEARING TEMP. DETECTORS
NUMBER AND TYPE: _____
5. SPACE HEATER 1 PHASE
VOLTS: 120 WATTS: 240
6. ROTATION: CCW VIEWED FROM NON DRIVE END
THIS MOTOR IS BI DIRECTIONAL
7. MOTOR PAINT COLOR: GRAY
8. APPROX. WEIGHT: 5000 Lbs
9. ACCESSORIES:

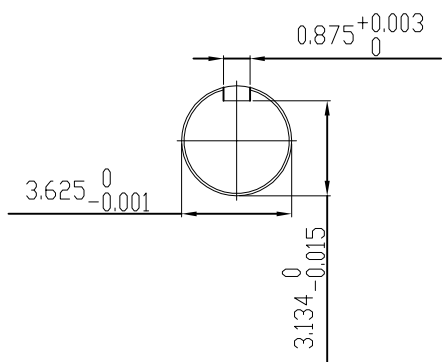

DRAWING LIST	
MAIN TERMINAL BOX	130-7622-55
AUX TERMINAL BOX FOR	
SPACE HEATER	130-7520-50
R.T.D.	130-7522-51
THERMISTOR	N/A
PRODUCTION #	N/A

NO.	REVISION	BY	DATE
1	JACKING TO INLINE ADD DOWELS	RWS	1/6/14
0	FIRST ISSUE	BCS	7/15/09

MOTOR OUTLINE FOR THREE PHASE INDUCTION MOTOR						
CUSTOMER NAME			P.O. NO.	MOTOR TAG NO.		
OUTPUT HP	POLE	VOLTAGE V	FREQUENCY Hz	FULL LOAD SPEED (min ⁻¹)	TOSHIBA MODEL NO.	
TYPE	FORM	INS. CLASS	RATING	FRAME	S.F.	ENCLOSURE
		F	CONT.	5011US		TEFC
TOSHIBA INTERNATIONAL CORPORATION HOUSTON, TEXAS U.S.A.						
3rd ANGLE PROJ.	PREPARED BY:	DATE:	CHECKED BY:	DATE:	DRAWING NO.:	REV.
	B SIDLE	7/15/09	EDDIE R.	7/16/09	MDSL0071-21	1

TYPICAL MOTOR PERFORMANCE DATA

Model: 5004FTQL11E-C

HP	kW	Pole	FL RPM	Frame	Voltage	Hz	Phase	FL Amps
500	373	4	1780	5011US	4000	60	3	62
Enclosure	IP	Ins. Class	S.F.	Duty	NEMA Nom. Eff.	NEMA Design	kVA Code	Ambient (°C)
TEFC	44	F	1.15	CONT	94.1	B	F	40 C

Load	HP	kW	Amperes	Efficiency (%)	Power Factor (%)
Full Load	500	372.9	61.7	94.4	92.4
¾ Load	375.00	279.6	46.5	94.3	92.0
½ Load	250.00	186.4	32.2	93.5	89.2
¼ Load	125.00	93.2	19.5	90.2	76.2
No Load			11.9		7.9
Locked Rotor			399.00		31.9

Torque				Rotor wk ²
Full Load (lb-ft)	Locked Rotor (% FLT)	Pull Up (% FLT)	Break Down (% FLT)	Inertia (lb-ft ²)
1474	170	175	270	199.27

Safe Stall Time(s)		Sound Pressure dB(A) @ 1M	Bearings*		Approx. Motor Weight (lbs)
Cold	Hot		DE	NDE	
39	15.6	-	M9-90 INS	M9-90 INS	

*Bearings are the only recommended spare part(s).

Motor Options:
Product Family:TEFC
Mounting:Footed,Shaft:US Shaft

Customer	
Customer PO	
Sales Order	
Project #	

Tag:

All characteristics are average expected values.

TOSHIBA INTERNATIONAL CORPORATION · HOUSTON, TEXAS U.S.A.

Engineering	bmmamen	Doc. Written By	D. Suarez	Doc.# / Rev	MPCF-1119 / 0
Engr. Date	7/9/2014	Doc. Approved By	M. Campbell	Doc. Issued	6/8/2011

SPEED TORQUE/CURRENT CURVE

Model: 5004FTQL11E-C

HP	kW	Pole	FL RPM	Frame	Voltage	Hz	Phase	FL Amps
500	373	4	1780	5011US	4000	60	3	62
Enclosure	IP	Ins. Class	S.F.	Duty	NEMA Nom. Eff.	NEMA Design	kVA Code	Ambient (°C)
TEFC	44	F	1.15	CONT	94.1	B	F	40 C
Locked Rotor Amps	Rotor wk ² Inertia (lb-ft ²)	Torque						Break Down (%)
		Full Load (lb-ft)	Locked Rotor (%)	Pull Up (%)				
399.00	199.27	1474	170	175			270	

Design Values

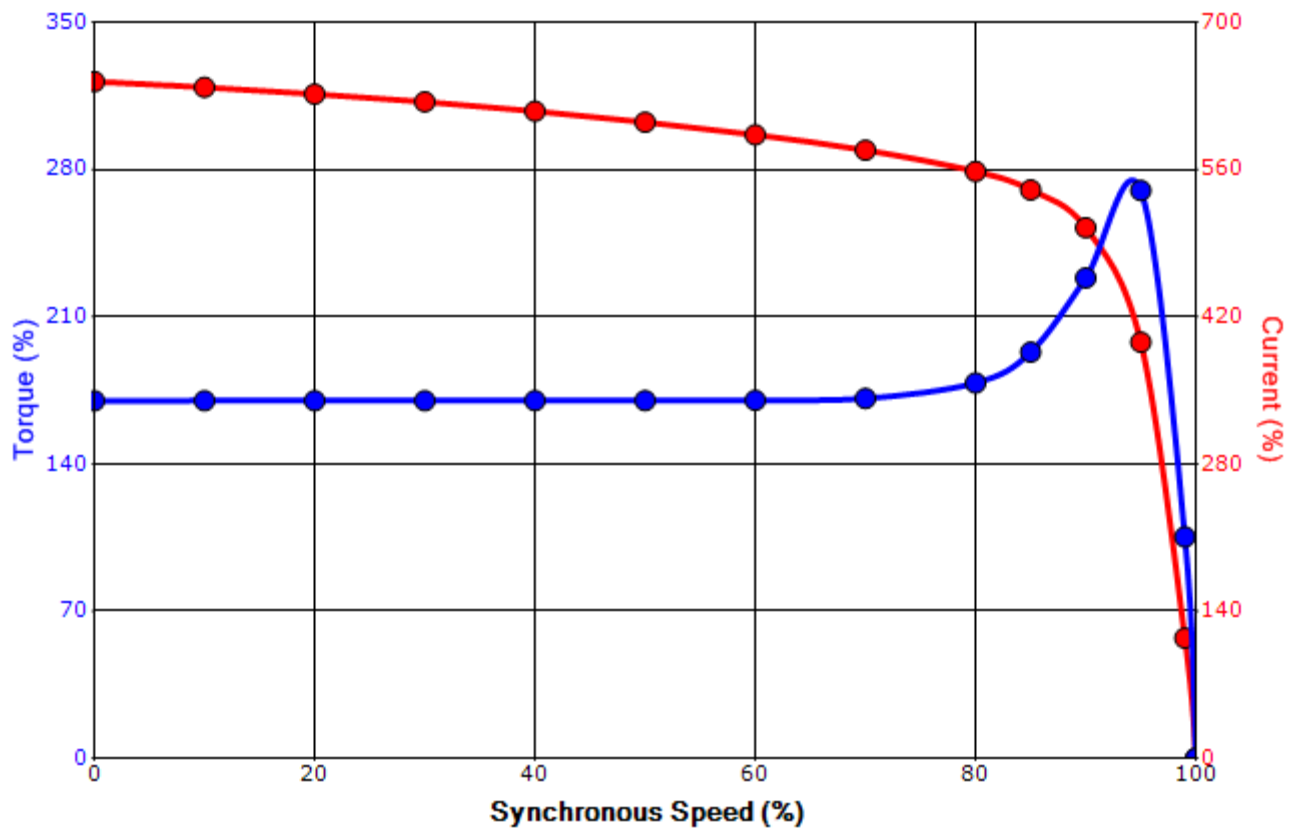

Customer		wk ² Load Inertia (lb-ft ²)	-
Customer PO		Load Type	-
Sales Order		Voltage (%)	100
Project #		Accel. Time	-

Tag:

All characteristics are average expected values.

TOSHIBA INTERNATIONAL CORPORATION · HOUSTON, TEXAS U.S.A.

Engineering	bmammen	Doc. Written By	D. Suarez	Doc.# / Rev	MPCF-1121 / 0
Engr. Date	7/9/2014	Doc. Approved By	M. Campbell	Doc. Issued	6/8/2011

Motor Connection Diagrams
6 Leads

Across the Line Starting / Run - Delta:



Alternate Starting Connection - Wye:



Switch L1 and L2 to reverse rotation