

TECHNICAL INFORMATION

- BEARING LUBRICATION DE: MOBIL POLYREX EM
ODE: MOBIL POLYREX EM
- BEARING TYPE DE: 6315C3
ODE: 6315C3 (INSULATED)
- WINDING TEMP. DETECTORS
NUMBER AND TYPE: 6xRTD(Pt0°C-100ohm)
LOCATION: IN STATOR SLOT
- BEARING TEMP. DETECTORS
NUMBER AND TYPE: N/A
- SPACE HEATER 1 PHASE
VOLTS: 120 WATTS: 400
- ROTATION: CCW VIEWED FROM NON DRIVE END
THIS MOTOR IS UNI DIRECTIONAL
- MOTOR PAINT COLOR: GRAY
- APPROX. WEIGHT: 5000 Lbs.
- ACCESSORIES:

DRAWING LIST

MAIN TERMINAL BOX 130-7622-55					
AUX TERMINAL BOX FOR					
SPACE HEATER	130-7520-50				
R.T.D.	130-7522-51				
THERMISTOR	-	1	UPDATE	RWS	1/2/14
PRODUCTION #	-	0	FIRST ISSUE	MH	012904
UNITS:	INCHES	NO.	REVISION	BY	DATE

**MOTOR OUTLINE FOR
THREE PHASE INDUCTION MOTOR**

CUSTOMER NAME			P.O. NO.		MOTOR TAG NO.	
OUTPUT 600 HP	POLE 2	VOLTAGE 2300 / 4160V	FREQUENCY 60 Hz	FULL LOAD SPEED 3575 (min ⁻¹)	TOSHIBA MODEL NO. 6003WPAK11F-C	
TYPE TIKE	FORM DCK1	INS. CLASS F	RATING CONT.	FRAME 5011/12USS	S.F. 1.15	ENCLOSURE WP-I
TOSHIBA INTERNATIONAL CORPORATION HOUSTON, TEXAS U.S.A.						
3rd ANGLE PROJ.	PREPARED BY: M.HO	DATE: 012904	CHECKED BY: D. HENSLEY	DATE: 012904	DRAWING NO.: MDSL0086-05	REV. 1

TOSHIBA INTERNATIONAL CORPORATION
Industrial Division / Houston Motor Plant

**SQUIRREL CAGE INDUCTION MOTOR
 PERFORMANCE SPECIFICATIONS**

INDEX	MPCF-1033
SHEET NO.	1 of 1
ISSUED	11/08/96
SUPERSEDES	10/06/95
REVISION	1
WRITTEN BY	R. EVANS
APPROVED BY	<i>Jay Bugbee</i>

Customer Tag:

CUSTOMER:
 TIC SR No.:
 Customer PO:

MOTOR NAMEPLATE DATA

H.P.: 600	VOLTS: 2300 / 4160	3 Ø / 60	Hz	S. RPM: 3600
FRAME: 5011/12 USS	ENCL: WPI	FLAMPS: 137 / 79		FLRPM: 3575
FORM: DCK1	S.F.: 1.15	NEMA DESIGN:		INSUL CLASS: F
TYPE: TIKE	AMB.: 40	CODE: E		DUTY: CONT.
MODEL No.: 6003WPAK11F-C		kW: 445		Serial No.:
NOM. EFF.: 94.1	MIN. EFF.: 93.0	P.F.: 87.4		

AMPERAGE Locked Rotor: 740 / 427	TORQUES FULL LOAD (lb-ft.): 881 LOCKED ROTOR (%): 85 BREAK DOWN (%): 255	** BEARINGS: Drive End: 6315C3 Opposite Drive End: 6315C3 INS
--	--	--

EFFICIENCY (%) FULL LOAD: 94.1 3/4 LOAD: 93.7 1/2 LOAD: 92.7	POWER FACTOR (%) FULL LOAD: 87.4 3/4 LOAD: 84.8 1/2 LOAD: 78.1
--	--

ALL CHARACTERISTICS ARE AVERAGE EXPECTED VALUES BASED UPON RATED VOLTAGE, FREQUENCY AND SINEWAVE POWER INPUT.

* TEMPERATURE RISE WILL BE CONSISTENT WITH INSULATION, AMBIENT AND SERVICE FACTOR AS DEFINED BY NEMA-MG-12.43 OR -20.40.

** BEARINGS ARE THE ONLY RECOMMENDED SPARE PART(S).

CERTIFIED BY:
DATE:

TOSHIBA

Reliability in Motion

TOSHIBA INTERNATIONAL CORPORATION

INDUSTRIAL DIVISION

PO BOX 40906

HOUSTON TX 77240

(713) 466-0277

(800) 231-1412

FAX (713) 466-8773

SPARE PARTS (RECOMMENDED)

OTHER THAN THE GREASE USED FOR RE-GREASABLE BEARINGS, **TOSHIBA** ADVISES THAT THERE ARE NO "USE" PARTS. THE ONLY INSURANCE SPARES THAT **TOSHIBA** SUGGESTS FOR THESE SQUIRREL CAGE INDUCTION MOTORS ARE INDUSTRY STANDARD, AND COMMERCIALY AVAILABLE ANTI-FRICTION BEARINGS, AS NOTED BELOW.

MOTOR COMPONENTS (SUCH AS TERMINAL BOXES, FAN COVERS, MACHINED PARTS) ARE AVAILABLE UPON SPECIAL REQUEST. IN THIS CASE, PLEASE ADVISE OUR ORDER ENTRY DEPARTMENT THE MODEL AND SERIAL NUMBERS (FOUND ON THE MOTOR NAMEPLATE) , AND A DESCRIPTION OF THE COMPONENT REQUIRED. THEY WILL THEN FURNISH THE CURRENT PART NUMBER, PRICE AND AVAILABILITY.

(NOTE: OUR INTERNAL PART NUMBERS ARE SUBJECT TO CHANGE WITHOUT NOTICE, AND ARE NOT PUBLISHED).

PLEASE ADVISE IF YOU HAVE ANY QUESTIONS.

CUSTOMER:
PURCHASE ORDER #
Customer Tag:

TOSHIBA FILE #
MODEL # 6003WPAK11F-C
HP / RPM / ENCL / FRAME: 600 / 3600 / WPI / 5011/12 USS
DRIVE END BEARING: 6315C3
OPPOSITE DRIVE END BEARING: 6315C3 INS

Prepared By:
Date:

Three Phase Motor Wiring Diagram
"Across the line" (Full Voltage) Starting

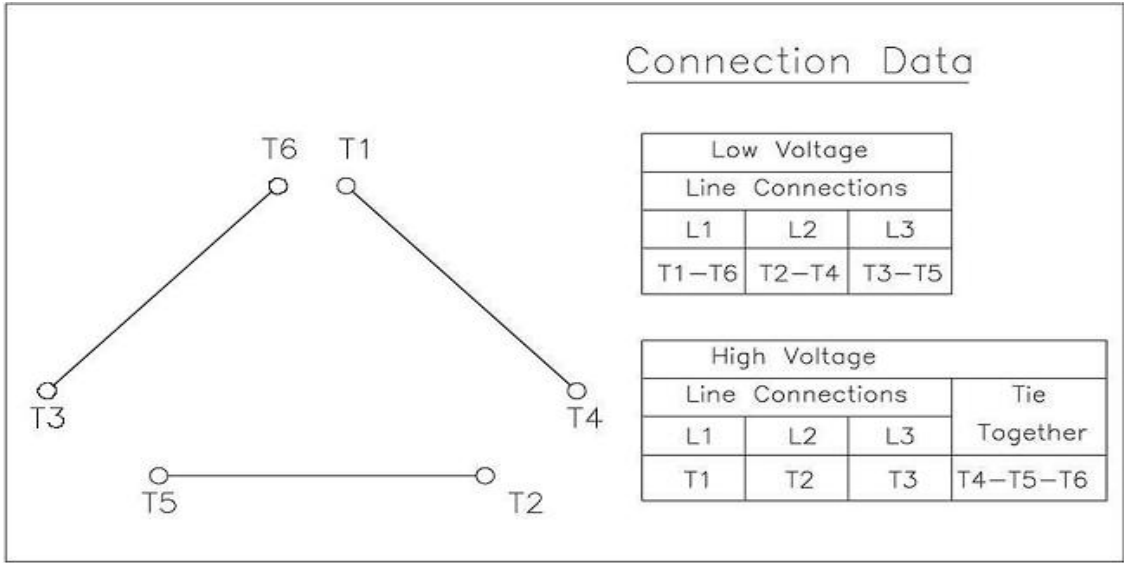

Customer Name:	
PO No.:	
Customer Tag:	
TIC File No.:	
Motor Model No.	6003WPAK11F-C

For Further Information Regarding Toshiba motor starting, maintenance or wiring,
 Please refer to the "Toshiba - A Quality Product for World Energy" Installation and
 Maintenance Manual, or contact the Toshiba Low Voltage Motor Marketing Department.
 (800) 231-1412

Prepared By:
 Date: