

**TECHNICAL INFORMATION**

1. BEARING LUBRICATION DE: MOBIL POLYREX EM  
ODE: MOBIL POLYREX EM
2. BEARING TYPE DE: 6315C3  
ODE: 6315C3 INSULATED
3. WINDING TEMP. DETECTORS  
NUMBER AND TYPE: 6xRTD(Pt0°C-100ohm)  
LOCATION: IN STATOR SLOT
4. BEARING TEMP. DETECTORS  
NUMBER AND TYPE: N/A
5. SPACE HEATER 1 PHASE  
VOLTS: 120 WATTS: 400
6. ROTATION: CCW VIEWED FROM NON DRIVE END  
THIS MOTOR IS UNI DIRECTIONAL
7. MOTOR PAINT COLOR: GRAY
8. APPROX. WEIGHT: 5000 Lbs.
9. ACCESORIES:

DRAWING LIST		NO.	REVISION	BY	DATE
MAIN TERMINAL BOX 130-7622-55					
AUX TERMINAL BOX FOR SPACE HEATER	130-7520-50	2	CHANGE AUX BOX DIM FROM 12.3	HL	3/16/20
R.T.D.	130-7522-51	1	GRS FROM SRI	RWS	1/2/14
THERMISTOR	-				
PRODUCTION #	-	0	FIRST ISSUE	MH	012904
UNITS:	INCHES				

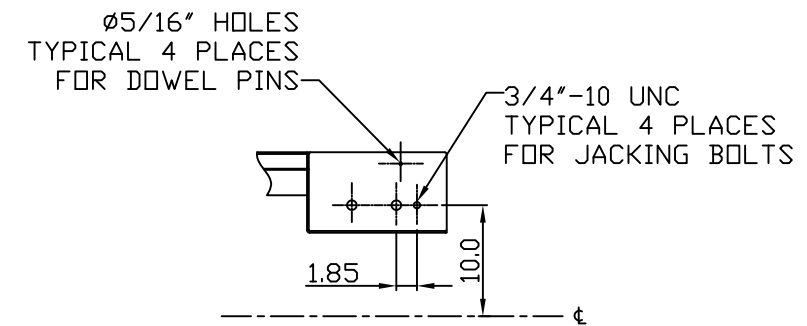

MOTOR OUTLINE FOR THREE PHASE INDUCTION MOTOR						
CUSTOMER NAME			P.O. NO.		MOTOR TAG NO.	
OUTPUT HP	POLE	VOLTAGE V	FREQUENCY Hz	FULL LOAD SPEED (min <sup>-1</sup> )	TOSHIBA MODEL NO.	
TYPE	FORM	INS. CLASS F	RATING CONT.	FRAME 5011/12USS	S.F.	ENCLOSURE WP-II
TOSHIBA INTERNATIONAL CORPORATION HOUSTON, TEXAS U.S.A.						
3rd ANGLE PROJ.	PREPARED BY: M.HO	DATE: 012904	CHECKED BY: D. HENSLEY	DATE: 012904	DRAWING NO.:	REV.
					MDSL0087-05	2

**TYPICAL MOTOR PERFORMANCE DATA**

Model: 6003WTAK11F-C

HP	kW	Pole	FL RPM	Frame	Voltage	Hz	Phase	FL Amps
600	447	2	3575	5012USS	4000	60	3	79
Enclosure	IP	Ins. Class	S.F.	Duty	NEMA Nom. Eff.	NEMA Design	kVA Code	Ambient (°C)
WP-II	24	F	1.15	CONT	94.3	-		40 C

Load	HP	kW	Amperes	Efficiency (%)	Power Factor (%)
Full Load	600.00	447.4	78	94.3	87.3
¾ Load	450.00	335.6	60	93.9	84.7
½ Load	300.00	223.7	44	92.9	78.0
¼ Load	150.00	111.9	27	89.4	65.9
No Load			18.8		8.8
Locked Rotor			427		17.4

Torque				Rotor wk <sup>2</sup>
Full Load (lb-ft)	Locked Rotor (% FLT)	Pull Up (% FLT)	Break Down (% FLT)	Inertia (lb-ft <sup>2</sup> )
881	85	90	255	103.60

Safe Stall Time(s)		Sound Pressure dB(A) @ 1M	Bearings*		Approx. Motor Weight (lbs)
Cold	Hot		DE	NDE	
26	19		6315C3	6315C3 INS	4500

\*Bearings are the only recommended spare part(s).

**Motor Options:**  
Product Family:WP-II  
Mounting:Footed,Shaft:USS Shaft

Customer	
Customer PO	
Sales Order	
Project #	

Tag:

All characteristics are average expected values.

**TOSHIBA INTERNATIONAL CORPORATION · HOUSTON, TEXAS U.S.A.**

Engineering	bammen	Doc. Written By	D. Suarez	Doc.# / Rev	MPCF-1119 / 0
Engr. Date	7/10/2014	Doc. Approved By	M. Campbell	Doc. Issued	6/8/2011

**SPEED TORQUE/CURRENT CURVE**

Model: 6003WTAK11F-C

HP	kW	Pole	FL RPM	Frame	Voltage	Hz	Phase	FL Amps
600	447	2	3575	5012USS	4000	60	3	79
Enclosure	IP	Ins. Class	S.F.	Duty	NEMA Nom. Eff.	NEMA Design	kVA Code	Ambient (°C)
WP-II	24	F	1.15	CONT	94.3	-		40 C
Locked Rotor Amps	Rotor wk <sup>2</sup> Inertia (lb-ft <sup>2</sup> )	Torque						Break Down (%)
		Full Load (lb-ft)	Locked Rotor (%)	Pull Up (%)				
427	103.60	881	85	90			255	

**Design Values**

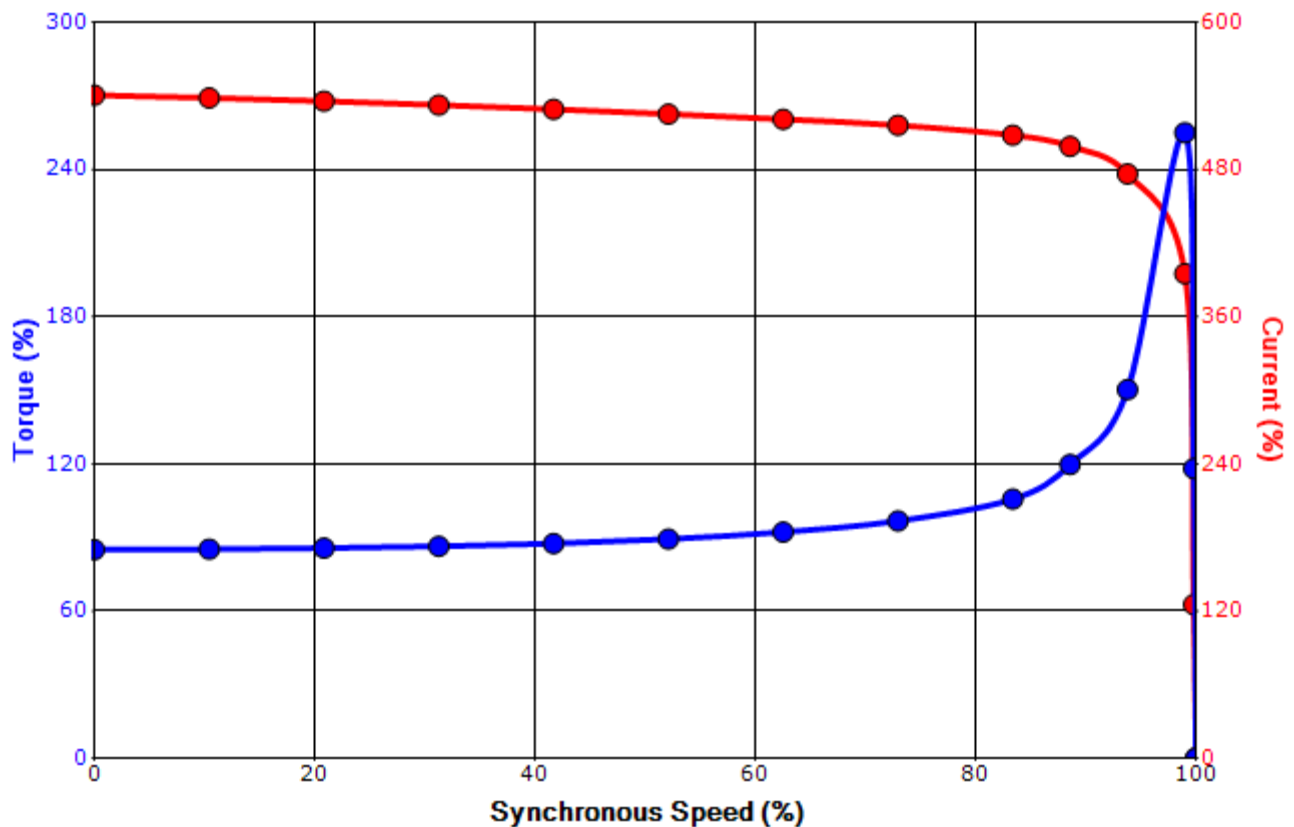

Customer		wk <sup>2</sup> Load Inertia (lb-ft <sup>2</sup> )	-
Customer PO		Load Type	-
Sales Order		Voltage (%)	100
Project #		Accel. Time	-

Tag:

All characteristics are average expected values.

**TOSHIBA INTERNATIONAL CORPORATION · HOUSTON, TEXAS U.S.A.**

Engineering	bmammen	Doc. Written By	D. Suarez	Doc.# / Rev	MPCF-1121 / 0
Engr. Date	7/10/2014	Doc. Approved By	M. Campbell	Doc. Issued	6/8/2011