

TYPE HS SQUIRREL CAGE INDUCTION MOTOR
ENCLOSURE - TOTALLY ENCLOSED FAN COOLED
AND EXPLOSION PROOF
BEARING - ANTI-FRICTION AND SOLID SLEEVE

NOTES

- A- THIS DRAWING IS NOT TO BE REGARDED AS INDICATING EXACT DETAILS OF CONSTRUCTION. IT IS PROPERLY DIMENSIONED FOR ERECTION PURPOSES ONLY.
- B- MOUNTING BOLTS, DOWELS AND COUPLING NOT SUPPLIED BY TOSHIBA UNLESS SPECIFICALLY ORDERED.
- C- WHEN MOUNTING MOTOR, SHIM COMPLETE FOOT PAD AREA.
- D- SLEEVE BEARINGS HAVE 0.50 MINIMUM ENDPLAY. COUPLING ENDFLOAT SHOULD BE 0.19 MAXIMUM WITH ROTOR LOCATED ON MECHANICAL CENTERLINE.
- E- UNLESS OTHERWISE SPECIFIED, CABLE PLATE OF THE MAIN CONDUIT BOX TO BE DRILLED BY CUSTOMER.
- F- FOR MOUNTING OF MOTOR USE 1.25-7 THD/INCH HOLD DOWN BOLTS.
- G- NON DRIVE END BEARING INSULATED.

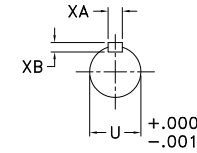
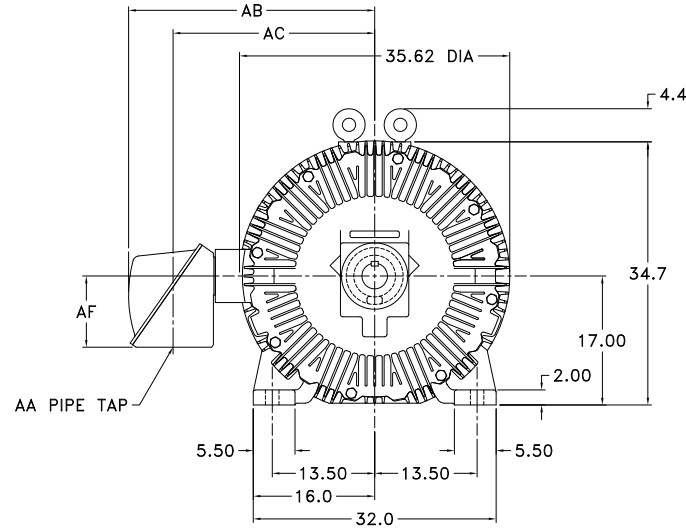
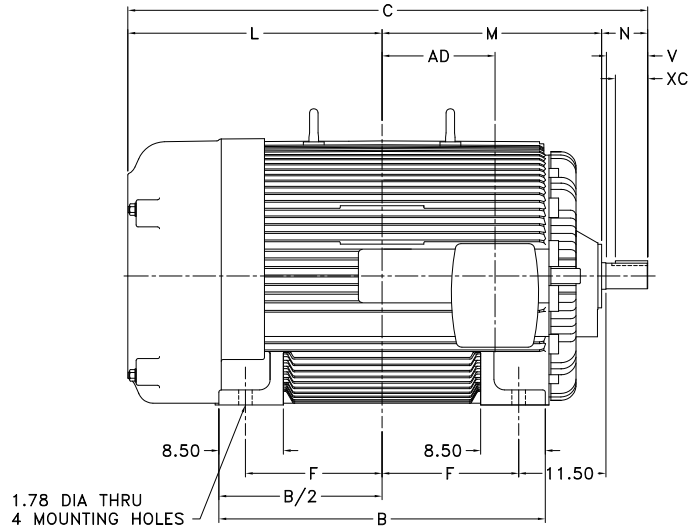

END VIEW OF SHAFT

FRAME SIZE	REAR SHAFT EXTENSION											RECOMMENDED COUPLING BORE		APPROX WEIGHT	
	U	KEY SIZE			N	V	B	C	F	L	M	AD	MIN.		MAX.
		XA	XB	XC											
686D	4.125	.937	.625	11.75	14.18	13.68	35.0	68.75	14.00	29.50	25.06	10.88	5725
686S	3.375	.937	.625	4.25	5.94	5.44	35.0	60.50	14.00	29.50	25.06	10.88	3.3720	3.3735	5675
686H	2.625	.625	.500	3.50	5.18	4.68	35.0	59.75	14.00	29.50	25.06	10.88	2.6230	2.6240	5650
688D	4.125	.937	.625	11.75	14.18	13.68	43.0	76.75	18.00	33.50	29.06	14.88	7000
688S	3.375	.937	.625	4.25	5.94	5.44	43.0	68.50	18.00	33.50	29.06	14.88	3.3720	3.3735	6950
688H	2.625	.625	.500	3.50	5.18	4.68	43.0	67.75	18.00	33.50	29.06	14.88	2.6230	2.6240	6925

CONDUIT BOX							
FAN COOLED - STANDARD				EXPLOSION PROOF			
AA	AB	AC	AF	AA	AB	AC	AF
3.00	32.50	26.56	9.38	3.00	35.75	27.50	13.00

THESE DRAWINGS ARE PREPARED IN ACCORDANCE WITH THE NORMAL AND ACCEPTED STANDARDS WITHIN THE ELECTRICAL INDUSTRY FOR THE PURPOSE OF OBTAINING CUSTOMER APPROVAL AS PART OF THE MANUFACTURING OR PRODUCTION PROCESS. ANY USE OR COMMUNICATION OF THE DRAWINGS BY THE CUSTOMER (OTHER THAN FOR OBTAINING APPROVAL) SHALL BE THE SOLE RESPONSIBILITY OF THE CUSTOMER.

PRELIMINARY SHAFT AND MOUNTING ONLY

G.O. _____ S.O. _____ CUST. ORDER _____

CUST. _____

RATING _____

PER: _____ DATE _____

TOSHIBA INDUSTRIAL PRODUCTS CANADA, STONEY CREEK

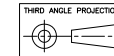

TOSHIBA INDUSTRIAL PRODUCTS CANADA

TITLE TYPE HS MOTOR FRAME 680

OUTLINE - TEFC/TEXP ENCLOSURE

SCALE: N.T.S. SHEET: OF

DATE: APPR BY: DATE: OF

DESIGNED: N.WEST APPR BY: SHEET: OF

E10D119

ISSUE 1 STANDARD REVISIONS



Issued Date

Transmit #

Issued By

Issued Rev

TYPICAL MOTOR PERFORMANCE DATA

Model: 6003XPQL11F-C

HP	kW	Pole	FL RPM	Frame	Voltage	Hz	Phase	FL Amps
600 hp	447 kW	2	3571 rpm	688H	4000 V	60	3	72.5 A
Enclosure	IP	Ins. Class	S.F.	Duty	NEMA Nom. Eff.	NEMA Design	kVA Code	Ambient (°C)
TEXP	55	F	1.15	Cont.	94.8	B	E	40

Load	HP	kW	Amperes	Efficiency (%)	Power Factor (%)
Full Load	600	447	72.5	94.8	94.4
¾ Load	450	336	53.9	94.5	95.3
½ Load	300	224	36.5	93.4	95.0
¼ Load	150	112			
No Load			8.5		14.9
Locked Rotor			455.2		20.3

Torque				Rotor wk ² Inertia (lb-ft ²)
Full Load (lb-ft)	Locked Rotor (% FLT)	Pull Up (% FLT)	Break Down (% FLT)	
886	96	96	213	174

Safe Stall Time(s)		Sound Pressure dB(A) @ 1M	Bearings*		Approx. Motor Weight (lbs)
Cold	Hot		DE	NDE	
36	32	-	Sleeve	Sleeve	7500

*Bearings are the only recommended spare part(s).

Motor Options:

Customer	
Customer PO	
Sales Order	
Project #	

Tag:

All characteristics are average expected values.

TOSHIBA INTERNATIONAL CORPORATION · HOUSTON, TEXAS U.S.A.

Engineering		Doc. Written By		Doc.# / Rev	
Engr. Date		Doc. Approved By		Doc. Issued	



Issued Date		Transmit #	
Issued By		Issued Rev	

NAMEPLATE DATA

Model: 6003XPQL11F-C

HP	kW	Pole	FL RPM	Frame	Voltage	Hz	Phase	FL Amps
600	447.414	2	3571	688H	4000	60	3	72.48
Enclosure	IP	Ins. Class	S.F.	Duty	NEMA Nom. Eff.	NEMA Design	kVA Code	Ambient (°C)
TEXP	55	F	1.15	Cont.	94.8	B	E	40

Type: HSB _____

Form: _____

Drive End Bearing: Sleeve _____

Non-Drive End Bearing: Sleeve _____

Power Factor: 94.4 _____

Max Safe RPM: _____

Comments 1: _____

Comments 2: _____

Comments 3: _____

Comments 4: _____

Customer		
Customer PO		
Sales Order		
Project #		

Tag:

All characteristics are average expected values.

TOSHIBA INTERNATIONAL CORPORATION · HOUSTON, TEXAS U.S.A.					
Engineering		Doc. Written By	D. Suarez	Doc.# / Rev	MPCF-1120 / 0
Engr. Date		Doc. Approved By	M. Campbell	Doc. Issued	6/8/2011



Issued Date		Transmit #	
Issued By		Issued Rev	

SPEED TORQUE/CURRENT CURVE

Model: 6003XPQL11F-C

HP	kW	Pole	FL RPM	Frame	Voltage	Hz	Phase	FL Amps
600	447.414	2	3571	688H	4000	60	3	72.48
Enclosure	IP	Ins. Class	S.F.	Duty	NEMA Nom. Eff.	NEMA Design	kVA Code	Ambient (°C)
TEXP	55	F	1.15	Cont.	94.8	B	E	40
Locked Rotor Amps	Rotor wk ² Inertia (lb-ft ²)	Torque						Break Down (%)
		Full Load (lb-ft)	Locked Rotor (%)	Pull Up (%)				
421.44	174	886.14	95.88552599		95.88552599		213.1028957	

Design Values

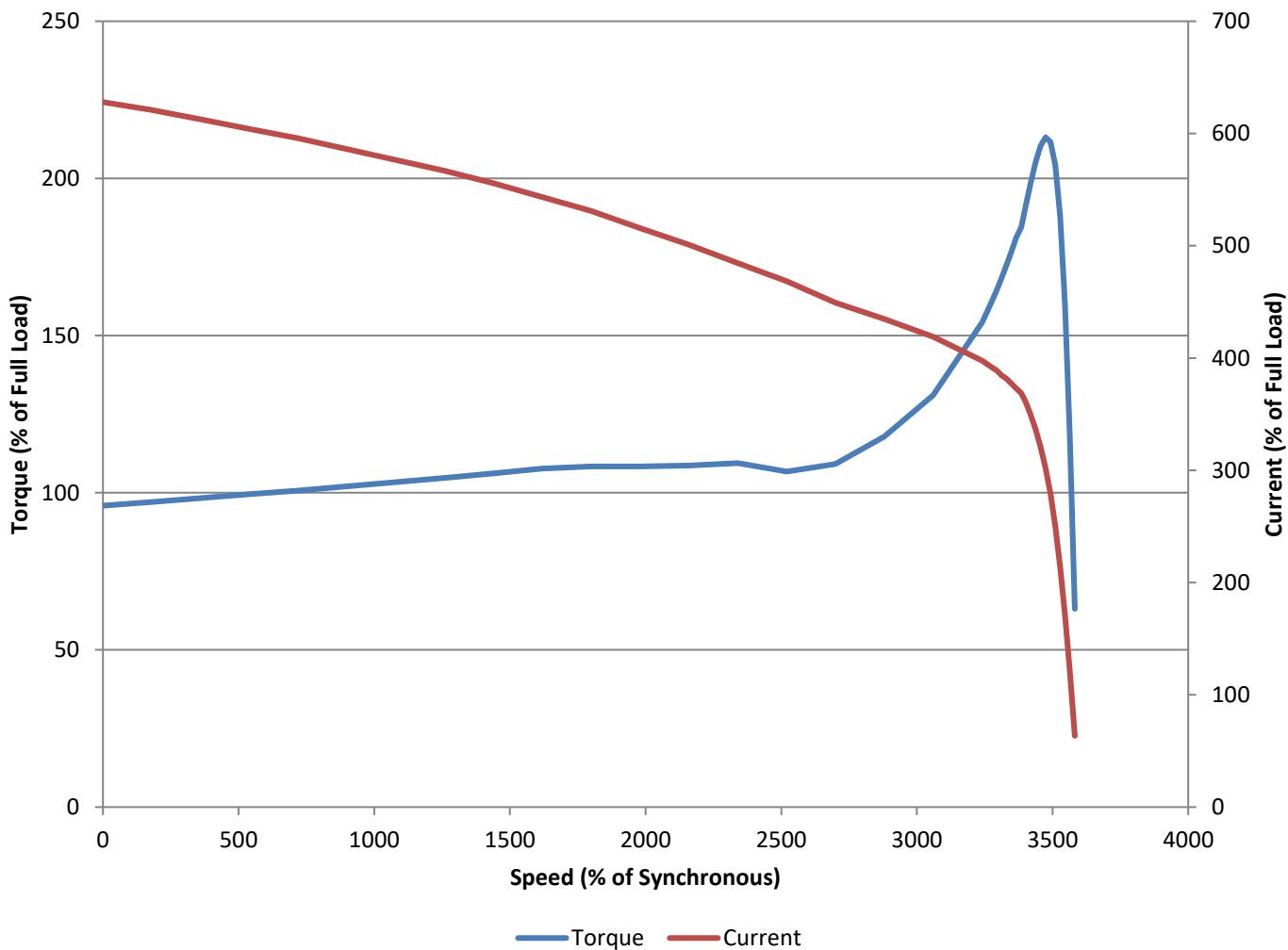

Customer		wk ² Load Inertia (lb-ft ²)		
Customer PO			Load Type	
Sales Order			Voltage (%)	100
Project #			Accel. Time	

Tag:

All characteristics are average expected values.

TOSHIBA INTERNATIONAL CORPORATION · HOUSTON, TEXAS U.S.A.

Engineering		Doc. Written By	D. Suarez	Doc.# / Rev	MPCF-1121/0
Engr. Date		Doc. Approved By	M. Campbell	Doc. Issued	6/8/2011



Issued Date

Transmit #

Issued By

Issued Rev

SPARE PARTS LIST*

Model: 6003XPQL11F-C

HP	kW	Pole	FL RPM	Frame	Voltage	Hz	Phase	FL Amps
600	447.414	2	3571	688H	4000	60	3	72.48
Enclosure	IP	Ins. Class	S.F.	Duty	NEMA Nom. Eff.	NEMA Design	kVA Code	Ambient (°C)
TEXP	55	F	1.15	Cont.	94.8	B	E	40

Bearings DE Sleeve

Bearings NDE Sleeve

*Bearings are the only recommended spare part(s).

Other than the grease used for regreasable bearings and the oil used for oil-lubricated bearings, Toshiba advises that there are no "use" parts. The only insurance spares that Toshiba suggests for these squirrel-cage induction motors are industry-standard and commercially available off-the-shelf bearings as noted above.

Motor components such as terminal boxes, fan covers and other machined parts are available on special request. In these cases, please advise our order entry department of the model and serial numbers found on the motor nameplate and a description of the needed components. With this information they will be able to furnish the current part number, price and availability.

Note: Our internal part numbers are subject to change without notice and are not published.

Customer	
Customer PO	
Sales Order	
Project #	

Tag:

All characteristics are average expected values.

TOSHIBA INTERNATIONAL CORPORATION · HOUSTON, TEXAS U.S.A.

Engineering		Doc. Written By	D. Suarez	Doc.# / Rev	MPCF-1125 / 0
Engr. Date		Doc. Approved By	M. Campbell	Doc. Issued	6/8/2011