

TECHNICAL INFORMATION

- BEARING LUBRICATION DE: MOBIL POLYREX EM
ODE: MOBIL POLYREX EM
- BEARING TYPE DE: 6326C3
ODE: 6326C3 INSULATED
- WINDING TEMP. DETECTORS
NUMBER AND TYPE: 6xRTD(Pt0°C-100ohm)
LOCATION: IN STATOR SLOT
- BEARING TEMP. DETECTORS
NUMBER AND TYPE: _____
- SPACE HEATER 1 PHASE
VOLTS: 120 WATTS: 400
- ROTATION: CCW VIEWED FROM NON DRIVE END
THIS MOTOR IS BI DIRECTIONAL
- MOTOR PAINT COLOR: _____
- APPROX. WEIGHT: 7300 Lbs
- ACCESORIES: _____

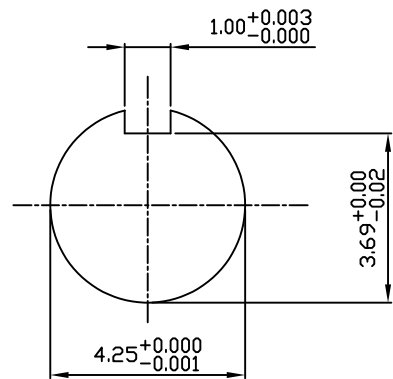

DRAWING LIST

MAIN TERMINAL BOX 130-7532-02					
AUX TERMINAL BOX FOR					
SPACE HEATER	130-7520-50				
R.T.D.	130-7522-51				
THERMISTOR	N/A				
		5	CHANGE AUX BOX DIM FROM 14.6 CHANGE JACKING BOLTS FROM 4	HL	3/16/20
PRODUCTION #	N/A	NO.	REVISION	BY	DATE

**MOTOR OUTLINE FOR
THREE PHASE INDUCTION MOTOR**

CUSTOMER NAME				P.O. NO.	MOTOR TAG NO.	
OUTPUT HP	POLE 8	VOLTAGE V	FREQUENCY Hz	FULL LOAD SPEED (min ⁻¹)	TOSHIBA MODEL NO.	
TYPE	FORM	INS. CLASS F	RATING CONT.	FRAME 5810/11/12	S.F.	ENCLOSURE WP-II
TOSHIBA INTERNATIONAL CORPORATION HOUSTON, TEXAS U.S.A.						
3rd ANGLE PROJ.	PREPARED BY: R.WILKINS	DATE: 03/25/03	CHECKED BY: M. HO	DATE: 04/01/03	DRAWING NO.: MDSL 0087-04	REV. 5

TYPICAL MOTOR PERFORMANCE DATA

Model: 6008WTAL11E-C

HP	kW	Pole	FL RPM	Frame	Voltage	Hz	Phase	FL Amps
600	447	8	890	5812US	4000	60	3	83
Enclosure	IP	Ins. Class	S.F.	Duty	NEMA Nom. Eff.	NEMA Design	kVA Code	Ambient (°C)
WP-II	24	F	1.15	CONT	95.4	-		40 C

Load	HP	kW	Amperes	Efficiency (%)	Power Factor (%)
Full Load	600.00	447.4	82	95.6	81.6
¾ Load	450.00	335.6	65	95.5	76.8
½ Load	300.00	223.7	51	94.6	66.3
¼ Load	150.00	111.9	41	91.0	43.2
No Load			34.3		4.1
Locked Rotor			439		25.7

Torque				Rotor wk ²
Full Load (lb-ft)	Locked Rotor (% FLT)	Pull Up (% FLT)	Break Down (% FLT)	Inertia (lb-ft ²)
3541	140	145	250	483.87

Safe Stall Time(s)		Sound Pressure dB(A) @ 1M	Bearings*		Approx. Motor Weight (lbs)
Cold	Hot		DE	NDE	
35	15	-	6326C3	6326C3 INS	

*Bearings are the only recommended spare part(s).

Motor Options:
Product Family:WP-II
Mounting:Footed,Shaft:US Shaft

Customer	
Customer PO	
Sales Order	
Project #	

Tag:

All characteristics are average expected values.

TOSHIBA INTERNATIONAL CORPORATION · HOUSTON, TEXAS U.S.A.

Engineering	bmmamen	Doc. Written By	D. Suarez	Doc.# / Rev	MPCF-1119 / 0
Engr. Date	7/14/2014	Doc. Approved By	M. Campbell	Doc. Issued	6/8/2011

SPEED TORQUE/CURRENT CURVE

Model: 6008WTAL11E-C

HP	kW	Pole	FL RPM	Frame	Voltage	Hz	Phase	FL Amps
600	447	8	890	5812US	4000	60	3	83
Enclosure	IP	Ins. Class	S.F.	Duty	NEMA Nom. Eff.	NEMA Design	kVA Code	Ambient (°C)
WP-II	24	F	1.15	CONT	95.4	-		40 C
Locked Rotor Amps	Rotor wk ² Inertia (lb-ft ²)	Torque						Break Down (%)
		Full Load (lb-ft)	Locked Rotor (%)	Pull Up (%)				
439	483.87	3541	140	145			250	

Design Values

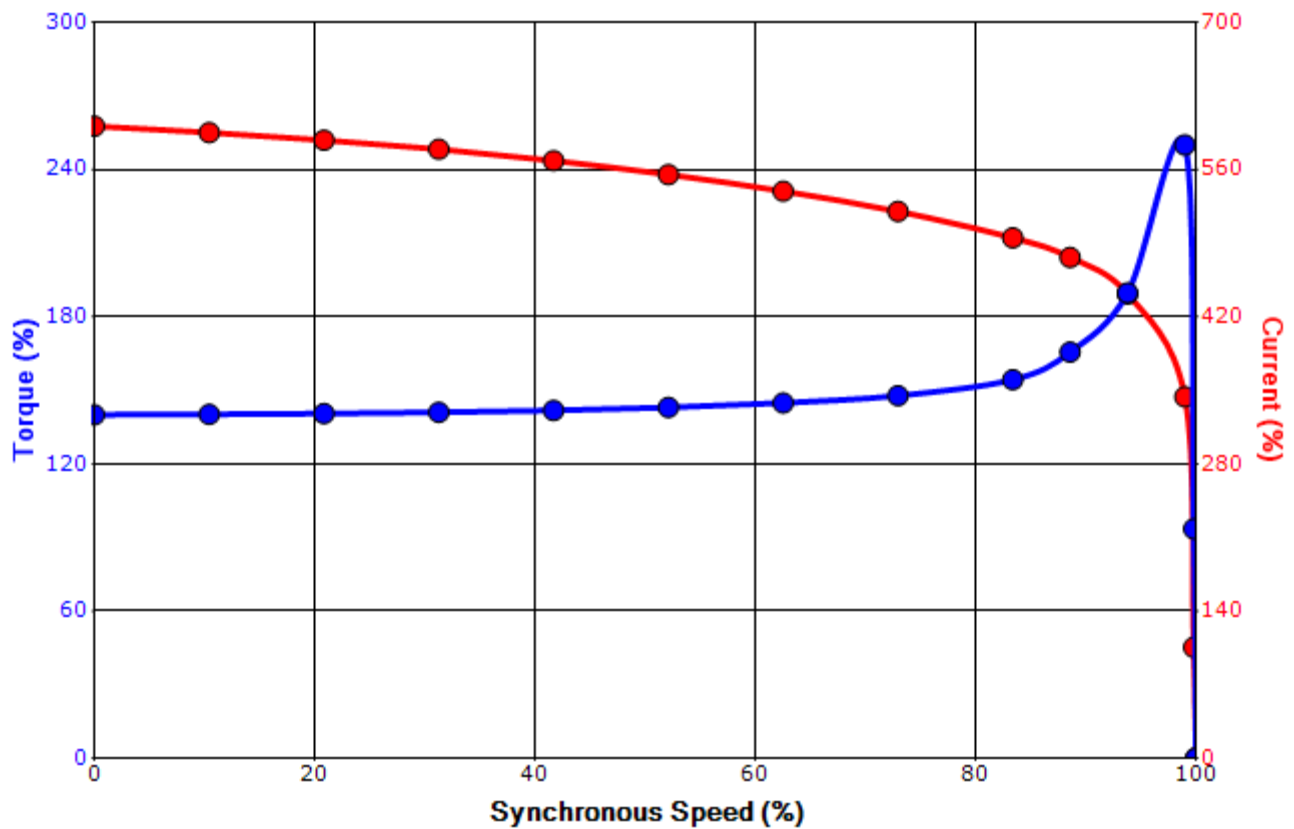

Customer		wk ² Load Inertia (lb-ft ²)	-
Customer PO		Load Type	-
Sales Order		Voltage (%)	100
Project #		Accel. Time	-

Tag:

All characteristics are average expected values.

TOSHIBA INTERNATIONAL CORPORATION · HOUSTON, TEXAS U.S.A.

Engineering	bmammen	Doc. Written By	D. Suarez	Doc.# / Rev	MPCF-1121 / 0
Engr. Date	7/14/2014	Doc. Approved By	M. Campbell	Doc. Issued	6/8/2011