

**TYPE HS SQUIRREL CAGE INDUCTION MOTOR ENCLOSURE - TOTALLY ENCLOSED FAN COOLED AND EXPLOSION PROOF BEARING - ANTI-FRICTION AND SOLID SLEEVE**

- NOTES**
- A- THIS DRAWING IS NOT TO BE REGARDED AS INDICATING EXACT DETAILS OF CONSTRUCTION. IT IS PROPERLY DIMENSIONED FOR ERECTION PURPOSES ONLY.
  - B- AIR INLET OPENINGS ARE ON BOTH ENDS OF MOTOR. WHEN INSTALLING MOTOR, AVOID LOCATING MOTOR SO THAT ADJACENT STRUCTURES ARE CLOSER THAN 12 INCHES TO MOTOR ENDS. ALSO THAT NO ADJACENT STRUCTURE CAUSES EXHAUST AIR TO BE DIRECTED INTO INLET OPENINGS.
  - C- MOUNTING BOLTS, DOWELS AND COUPLING NOT SUPPLIED BY TOSHIBA UNLESS SPECIFICALLY ORDERED.
  - D- EACH FOOT MUST BE MOUNTED ON A BASE EQUAL TO OR LARGER THAN THE PAD AREA.
  - E- SLEEVE BEARINGS HAVE 0.50 MINIMUM ENDPLAY. COUPLING ENDFLOAT SHOULD BE 0.19 MAXIMUM WITH ROTOR LOCATED ON MECHANICAL CENTERLINE.
  - F- FOR MOUNTING OF MOTOR USE .875-9 THD/INCH HOLD DOWN BOLTS.
  - G- NON DRIVE END BEARING INSULATED.
- DEVICES

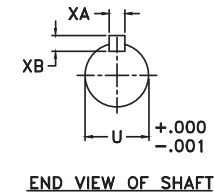
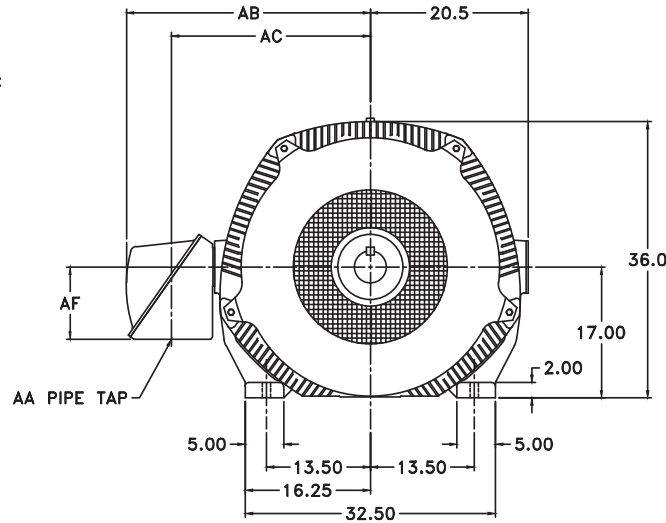
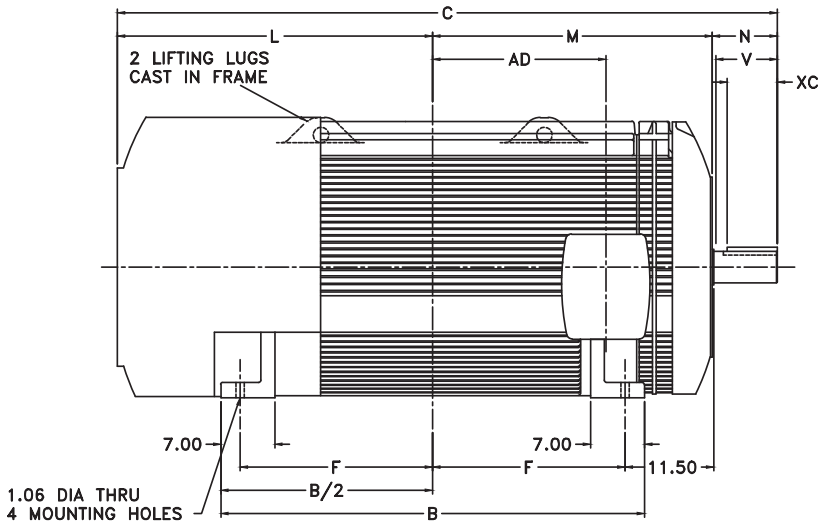

FRAME SIZE	REAR SHAFT EXTENSION							RECOMMENDED COUPLING BORE		APPROX WEIGHT					
	U	KEY SIZE			N	V	B	C	F		L	M	AD	MIN.	MAX.
		XA	XB	XC											
6809H	2.875	.750	.750	4.00	5.94	5.50	45.0	73.20	20.00	35.94	31.32	17.50	2.8730	2.8740	9400
6809L	4.125	1.000	1.000	6.50	8.44	8.00	45.0	75.70	20.00	35.94	31.32	17.50	4.1215	4.1230	10090
6810H	2.875	.750	.750	4.00	5.94	5.50	50.0	78.20	22.50	38.44	33.82	20.00	2.8730	2.8740	10430
6810L	4.125	1.000	1.000	6.50	8.44	8.00	50.0	80.70	22.50	38.44	33.82	20.00	4.1215	4.1230	11230
6811H	2.875	.750	.750	4.00	5.94	5.50	55.0	83.20	25.00	40.94	36.32	22.50	2.8730	2.8740	11610
6811L	4.125	1.000	1.000	6.50	8.44	8.00	55.0	85.70	25.00	40.94	36.32	22.50	4.1215	4.1230	12350

CONDUIT BOX							
FAN COOLED - STANDARD				EXPLOSION PROOF			
AA	AB	AC	AF	AA	AB	AC	AF
3.00	31.68	25.81	9.38	3.00	35.00	26.50	13.00

THESE DRAWINGS ARE PREPARED IN ACCORDANCE WITH THE NORMAL AND ACCEPTED STANDARDS WITHIN THE ELECTRICAL INDUSTRY FOR THE PURPOSE OF OBTAINING CUSTOMER APPROVAL AS PART OF THE MANUFACTURING OR PRODUCTION PROCESS. ANY USE OR COMPARISON OF THE DIMENSIONS BY THE CUSTOMER (OTHER THAN FOR GRANTING APPROVAL) SHALL BE THE SOLE RESPONSIBILITY OF THE CUSTOMER.

PRELIMINARY SHAFT AND MOUNTING ONLY  
 G.O. \_\_\_\_\_ S.O. \_\_\_\_\_ CUST. ORDER \_\_\_\_\_  
 CUST. \_\_\_\_\_  
 RATING \_\_\_\_\_  
 PER: \_\_\_\_\_ DATE \_\_\_\_\_  
 TOSHIBA INDUSTRIAL PRODUCTS CANADA, STONEY CREEK

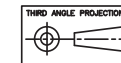

<small>THE INFORMATION CONTAINED HEREIN IS THE PROPERTY OF TOSHIBA INDUSTRIAL PRODUCTS CANADA - IT MUST NOT BE REPRODUCED OR DISCLOSED TO ANY OTHER PARTY WITHOUT THE EXPRESS PERMISSION OF TOSHIBA INDUSTRIAL PRODUCTS CANADA.</small>				<b>TOSHIBA</b>	
TITLE TYPE HS MOTOR FRAME 6800					
OUTLINE - TEFC/TEXP ENCLOSURE					
ENGINEER	SCALE	N.T.S.	SHEET	OF	
DESIGNED BY	DATE	APP'D	DATE		
CHECKED	N.WEST	APP'D			
CHECKED		APP'D			

E10D120

STANDARD REVISIONS  
 1



Issued Date

Transmit #

Issued By

Issued Rev

## TYPICAL MOTOR PERFORMANCE DATA

Model: 7003XPQL11F-C

HP	kW	Pole	FL RPM	Frame	Voltage	Hz	Phase	FL Amps
700 hp	522 kW	2	3580 rpm	6810H	4000 V	60	3	86.0 A
Enclosure	IP	Ins. Class	S.F.	Duty	NEMA Nom. Eff.	NEMA Design	kVA Code	Ambient (°C)
TEXP	55	F	1.15	Cont.	94.9	B	F	40

Load	HP	kW	Amperes	Efficiency (%)	Power Factor (%)
Full Load	700	522	86.0	94.9	92.9
¾ Load	525	391	66.3	94.2	92.5
½ Load	350	261	45.6	92.5	89.4
¼ Load	175	130			
No Load			17.4		12.2
Locked Rotor			541.6		12.3

Torque				Rotor wk <sup>2</sup> Inertia (lb-ft <sup>2</sup> )
Full Load (lb-ft)	Locked Rotor (% FLT)	Pull Up (% FLT)	Break Down (% FLT)	
1032	78	75	246	310

Safe Stall Time(s)		Sound Pressure dB(A) @ 1M	Bearings*		Approx. Motor Weight (lbs)
Cold	Hot		DE	NDE	
62	54	-	Sleeve	Sleeve	11000

\*Bearings are the only recommended spare part(s).

## Motor Options:

Customer	
Customer PO	
Sales Order	
Project #	

Tag:

All characteristics are average expected values.

TOSHIBA INTERNATIONAL CORPORATION · HOUSTON, TEXAS U.S.A.

Engineering		Doc. Written By		Doc.# / Rev	
Engr. Date		Doc. Approved By		Doc. Issued	



Issued Date

Transmit #

Issued By

Issued Rev

NAMEPLATE DATA

Model: 7003XPQL11F-C

HP	kW	Pole	FL RPM	Frame	Voltage	Hz	Phase	FL Amps
700	521.983	2	3580	6810H	4000	60	3	85.95
Enclosure	IP	Ins. Class	S.F.	Duty	NEMA Nom. Eff.	NEMA Design	kVA Code	Ambient (°C)
TEXP	55	F	1.15	Cont.	94.9	B	F	40

Type: HSB

Form:

Drive End Bearing: Sleeve

Non-Drive End Bearing: Sleeve

Power Factor: 92.9

Max Safe RPM:

Comments 1:

Comments 2:

Comments 3:

Comments 4:

Customer

Customer PO

Sales Order

Project #

Tag:

All characteristics are average expected values.

TOSHIBA INTERNATIONAL CORPORATION · HOUSTON, TEXAS U.S.A.

Engineering	Doc. Written By	D. Suarez	Doc.# / Rev	MPCF-1120 / 0
Engr. Date	Doc. Approved By	M. Campbell	Doc. Issued	6/8/2011



Issued Date		Transmit #	
Issued By		Issued Rev	

### SPEED TORQUE/CURRENT CURVE

Model: 7003XPQL11F-C

HP	kW	Pole	FL RPM	Frame	Voltage	Hz	Phase	FL Amps
700	521.983	2	3580	6810H	4000	60	3	85.95
Enclosure	IP	Ins. Class	S.F.	Duty	NEMA Nom. Eff.	NEMA Design	kVA Code	Ambient (°C)
TEXP	55	F	1.15	Cont.	94.9	B	F	40
Locked Rotor Amps	Rotor wk <sup>2</sup> Inertia (lb-ft <sup>2</sup> )	Torque				Pull Up (%)	Break Down (%)	
		Full Load (lb-ft)	Locked Rotor (%)					
520.77	310	1032.17	78.49288392		75.29450288	246.4787777		

### Design Values

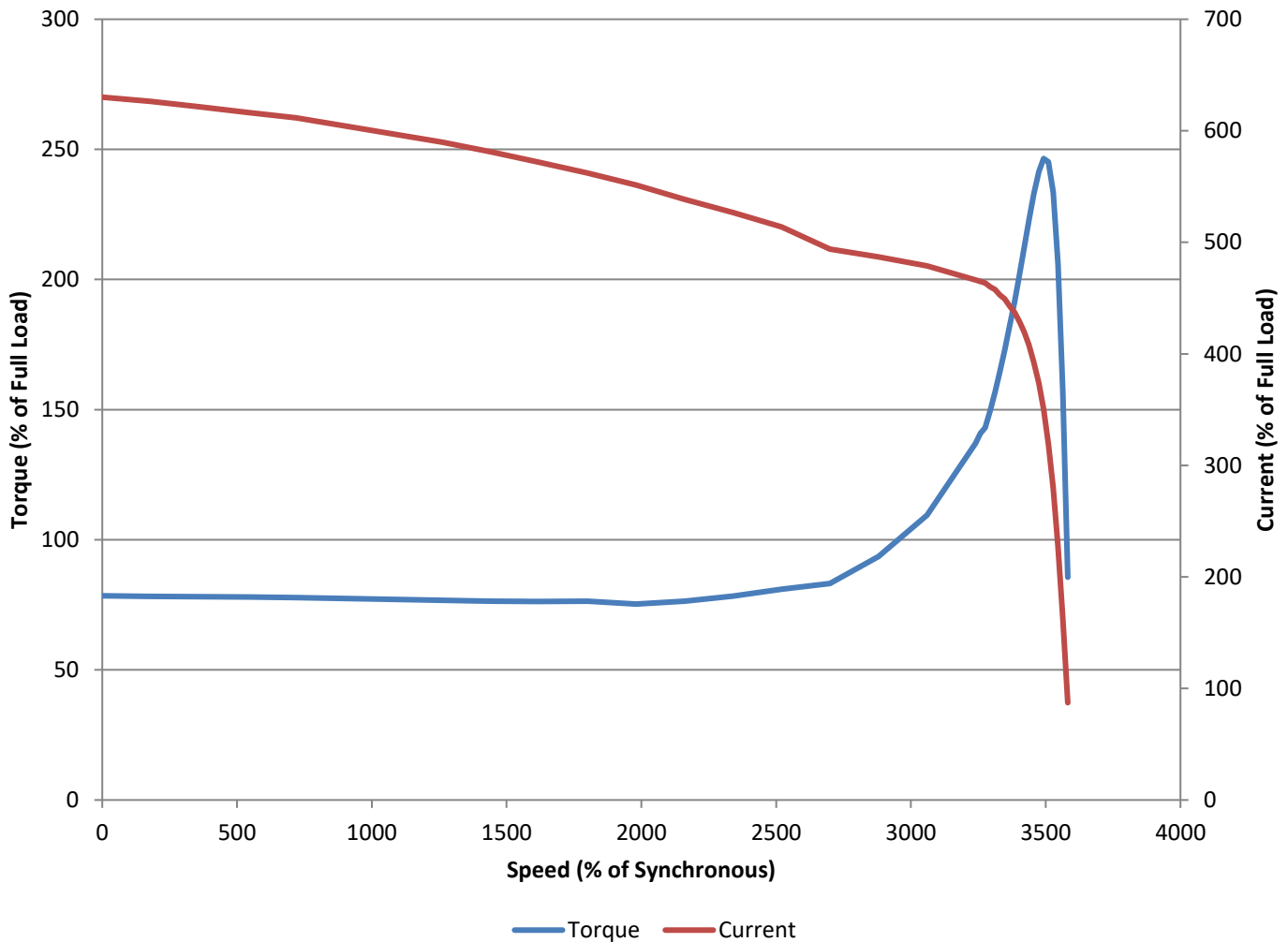

Customer		wk <sup>2</sup> Load Inertia (lb-ft <sup>2</sup> )		
Customer PO			Load Type	
Sales Order			Voltage (%)	100
Project #			Accel. Time	

Tag:

All characteristics are average expected values.

TOSHIBA INTERNATIONAL CORPORATION · HOUSTON, TEXAS U.S.A.

Engineering		Doc. Written By	D. Suarez	Doc.# / Rev	MPCF-1121/0
Engr. Date		Doc. Approved By	M. Campbell	Doc. Issued	6/8/2011



Issued Date

Transmit #

Issued By

Issued Rev

## SPARE PARTS LIST\*

Model: 7003XPQL11F-C

HP	kW	Pole	FL RPM	Frame	Voltage	Hz	Phase	FL Amps
700	521.983	2	3580	6810H	4000	60	3	85.95
Enclosure	IP	Ins. Class	S.F.	Duty	NEMA Nom. Eff.	NEMA Design	kVA Code	Ambient (°C)
TEXP	55	F	1.15	Cont.	94.9	B	F	40

Bearings DE Sleeve

Bearings NDE Sleeve

\*Bearings are the only recommended spare part(s).

Other than the grease used for regreasable bearings and the oil used for oil-lubricated bearings, Toshiba advises that there are no "use" parts. The only insurance spares that Toshiba suggests for these squirrel-cage induction motors are industry-standard and commercially available off-the-shelf bearings as noted above.

Motor components such as terminal boxes, fan covers and other machined parts are available on special request. In these cases, please advise our order entry department of the model and serial numbers found on the motor nameplate and a description of the needed components. With this information they will be able to furnish the current part number, price and availability.

Note: Our internal part numbers are subject to change without notice and are not published.

Customer	
Customer PO	
Sales Order	
Project #	

Tag:

All characteristics are average expected values.

TOSHIBA INTERNATIONAL CORPORATION · HOUSTON, TEXAS U.S.A.

Engineering		Doc. Written By	D. Suarez	Doc.# / Rev	MPCF-1125 / 0
Engr. Date		Doc. Approved By	M. Campbell	Doc. Issued	6/8/2011