

TECHNICAL INFORMATION

1. BEARING LUBRICATION DE: MOBIL POLYREX EM
ODE: MOBIL POLYREX EM
2. BEARING TYPE DE: 6326C3
ODE: 6326C3 INSULATED
3. WINDING TEMP. DETECTORS
NUMBER AND TYPE: 6xRTD(Pt0°C-100ohm)
LOCATION: IN STATOR SLOT
4. BEARING TEMP. DETECTORS
NUMBER AND TYPE: _____
5. SPACE HEATER 1 PHASE
VOLTS: 120 WATTS: 400
6. ROTATION: CCW VIEWED FROM NON DRIVE END
THIS MOTOR IS BI DIRECTIONAL
7. MOTOR PAINT COLOR: _____
8. APPROX. WEIGHT: 7300 Lbs
9. ACCESORIES: _____

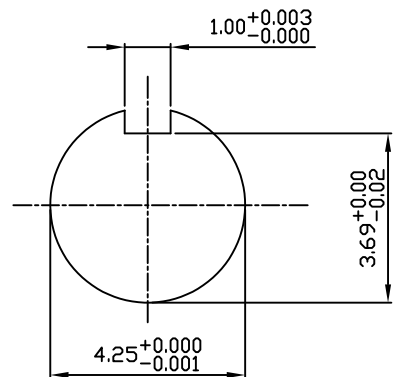

DRAWING LIST

MAIN TERMINAL BOX					
130-7532-02					
AUX TERMINAL BOX FOR					
SPACE HEATER	130-7520-50				
R.T.D.	130-7522-51				
THERMISTOR	N/A				
		5	CHANGE AUX BOX DIM FROM 14.6	HL	3/16/20
			CHANGE JACKING BOLTS FROM 4		
PRODUCTION #	N/A	NO.	REVISION	BY	DATE

**MOTOR OUTLINE FOR
THREE PHASE INDUCTION MOTOR**

CUSTOMER NAME				P.O. NO.	MOTOR TAG NO.	
OUTPUT HP	POLE 8	VOLTAGE V	FREQUENCY Hz	FULL LOAD SPEED (min ⁻¹)	TOSHIBA MODEL NO.	
TYPE	FORM	INS. CLASS F	RATING CONT.	FRAME 5810/11/12	S.F.	ENCLOSURE WP-II
TOSHIBA INTERNATIONAL CORPORATION HOUSTON, TEXAS U.S.A.						
3rd ANGLE PROJ.	PREPARED BY: R.WILKINS	DATE: 03/25/03	CHECKED BY: M. HO	DATE: 04/01/03	DRAWING NO.: MDSL 0087-04	REV. 5

TYPICAL MOTOR PERFORMANCE DATA

Model: 7008WTAL11E-A

HP	kW	Pole	FL RPM	Frame	Voltage	Hz	Phase	FL Amps
700	522	8	885	5812US	4000	60	3	108
Enclosure	IP	Ins. Class	S.F.	Duty	NEMA Nom. Eff.	NEMA Design	kVA Code	Ambient (°C)
WP-II	24	F	1.15	CONT	94.1	-		40 C

Load	HP	kW	Amperes	Efficiency (%)	Power Factor (%)
Full Load	700.00	522.0	108	94.2	73.8
¾ Load	525.00	391.5	88	94.1	68.0
½ Load	350.00	261.0	71	93.3	56.7
¼ Load	175.00	130.5	59	89.9	35.3
No Load			52.3		2.3
Locked Rotor			618		22.8

Torque				Rotor wk ² Inertia (lb-ft ²)
Full Load (lb-ft)	Locked Rotor (% FLT)	Pull Up (% FLT)	Break Down (% FLT)	
4154	155	95	245	518.44

Safe Stall Time(s)		Sound Pressure dB(A) @ 1M	Bearings*		Approx. Motor Weight (lbs)
Cold	Hot		DE	NDE	
11	5		6326C3	6326C3 INS	0

*Bearings are the only recommended spare part(s).

Motor Options:
Product Family:WP-II
Mounting:Footed,Shaft:US Shaft

Customer	
Customer PO	
Sales Order	
Project #	

Tag:

All characteristics are average expected values.

TOSHIBA INTERNATIONAL CORPORATION · HOUSTON, TEXAS U.S.A.

Engineering	bmmamen	Doc. Written By	D. Suarez	Doc.# / Rev	MPCF-1119 / 0
Engr. Date	7/14/2014	Doc. Approved By	M. Campbell	Doc. Issued	6/8/2011

SPEED TORQUE/CURRENT CURVE

Model: 7008WTAL11E-A

HP	kW	Pole	FL RPM	Frame	Voltage	Hz	Phase	FL Amps
700	522	8	885	5812US	4000	60	3	108
Enclosure	IP	Ins. Class	S.F.	Duty	NEMA Nom. Eff.	NEMA Design	kVA Code	Ambient (°C)
WP-II	24	F	1.15	CONT	94.1	-		40 C
Locked Rotor Amps	Rotor wk ² Inertia (lb-ft ²)	Torque						Break Down (%)
		Full Load (lb-ft)	Locked Rotor (%)	Pull Up (%)				
618	518.44	4154	155	95			245	

Design Values

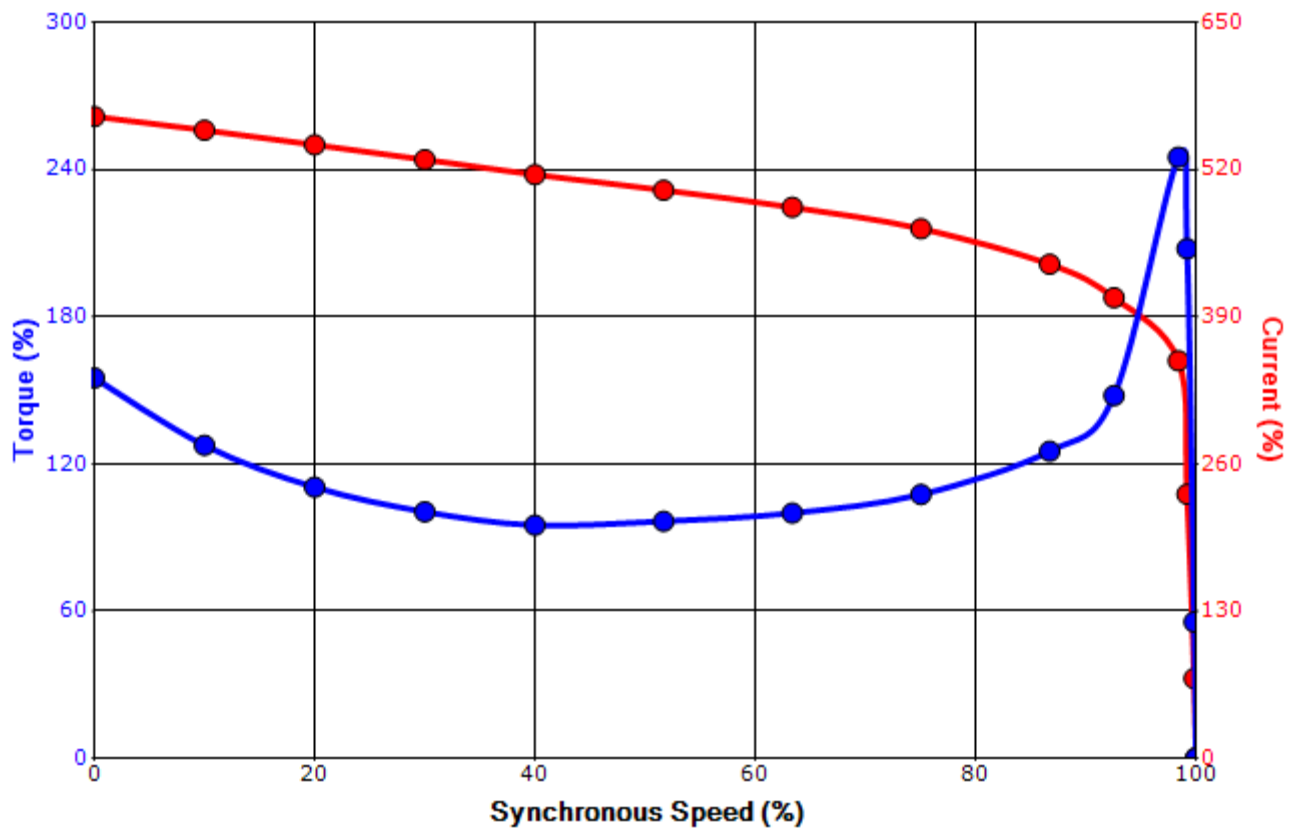

Customer		wk ² Load Inertia (lb-ft ²)	-
Customer PO		Load Type	-
Sales Order		Voltage (%)	100
Project #		Accel. Time	-

Tag:

All characteristics are average expected values.

TOSHIBA INTERNATIONAL CORPORATION · HOUSTON, TEXAS U.S.A.

Engineering	bmammen	Doc. Written By	D. Suarez	Doc.# / Rev	MPCF-1121 / 0
Engr. Date	7/14/2014	Doc. Approved By	M. Campbell	Doc. Issued	6/8/2011