

TYPE HS SQUIRREL CAGE INDUCTION MOTOR ENCLOSURE - TOTALLY ENCLOSED FAN COOLED AND EXPLOSION PROOF BEARING - ANTI-FRICTION AND SOLID SLEEVE

- NOTES**
A- THIS DRAWING IS NOT TO BE REGARDED AS INDICATING EXACT DETAILS OF CONSTRUCTION. IT IS PROPERLY DIMENSIONED FOR ERECTION PURPOSES ONLY.
B- AIR INLET OPENINGS ARE ON BOTH ENDS OF MOTOR. WHEN INSTALLING MOTOR, AVOID LOCATING MOTOR SO THAT ADJACENT STRUCTURES ARE CLOSER THAN 12 INCHES TO MOTOR ENDS. ALSO THAT NO ADJACENT STRUCTURE CAUSES EXHAUST AIR TO BE DIRECTED INTO INLET OPENINGS.
C- MOUNTING BOLTS, DOWELS AND COUPLING NOT SUPPLIED BY TOSHIBA UNLESS SPECIFICALLY ORDERED.
D- EACH FOOT MUST BE MOUNTED ON A BASE EQUAL TO OR LARGER THAN THE PAD AREA.
E- SLEEVE BEARINGS HAVE 0.50 MINIMUM ENDPLAY. COUPLING ENDFLOAT SHOULD BE 0.19 MAXIMUM WITH ROTOR LOCATED ON MECHANICAL CENTERLINE.
F- FOR MOUNTING OF MOTOR USE .875-9 THD/INCH HOLD DOWN BOLTS.
G- NON DRIVE END BEARING INSULATED.
DEVICES

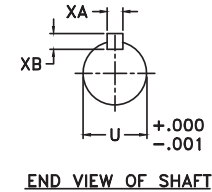
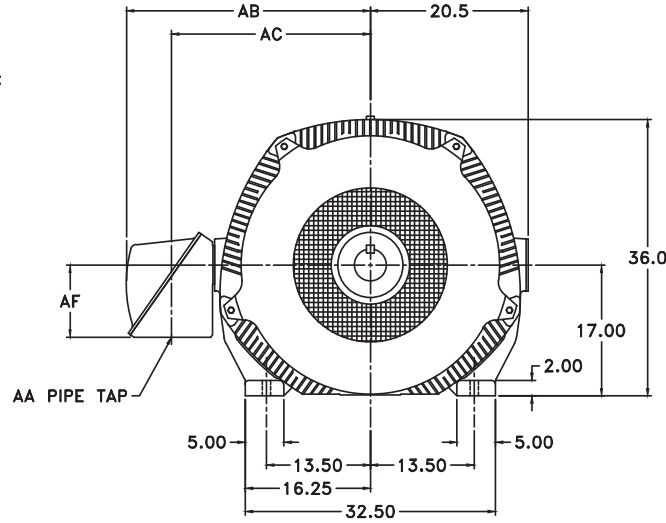
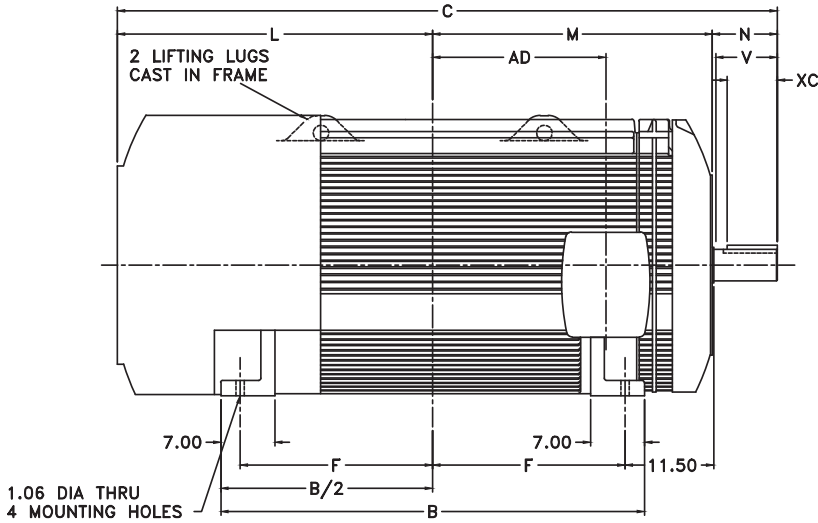

FRAME SIZE	REAR SHAFT EXTENSION							RECOMMENDED COUPLING BORE		APPROX WEIGHT					
	U	KEY SIZE			N	V	B	C	F		L	M	AD	MIN.	MAX.
		XA	XB	XC											
6809H	2.875	.750	.750	4.00	5.94	5.50	45.0	73.20	20.00	35.94	31.32	17.50	2.8730	2.8740	9400
6809L	4.125	1.000	1.000	6.50	8.44	8.00	45.0	75.70	20.00	35.94	31.32	17.50	4.1215	4.1230	10090
6810H	2.875	.750	.750	4.00	5.94	5.50	50.0	78.20	22.50	38.44	33.82	20.00	2.8730	2.8740	10430
6810L	4.125	1.000	1.000	6.50	8.44	8.00	50.0	80.70	22.50	38.44	33.82	20.00	4.1215	4.1230	11230
6811H	2.875	.750	.750	4.00	5.94	5.50	55.0	83.20	25.00	40.94	36.32	22.50	2.8730	2.8740	11610
6811L	4.125	1.000	1.000	6.50	8.44	8.00	55.0	85.70	25.00	40.94	36.32	22.50	4.1215	4.1230	12350

CONDUIT BOX							
FAN COOLED - STANDARD				EXPLOSION PROOF			
AA	AB	AC	AF	AA	AB	AC	AF
3.00	31.68	25.81	9.38	3.00	35.00	26.50	13.00

THESE DRAWINGS ARE PREPARED IN ACCORDANCE WITH THE NORMAL AND ACCEPTED STANDARDS WITHIN THE ELECTRICAL INDUSTRY FOR THE PURPOSE OF OBTAINING CUSTOMER APPROVAL AS PART OF THE MANUFACTURING OR PRODUCTION PROCESS. ANY USE OR COMPARISON OF THE DIMENSIONS BY THE CUSTOMER (OTHER THAN FOR GRANTING APPROVAL) SHALL BE THE SOLE RESPONSIBILITY OF THE CUSTOMER.

THE INFORMATION CONTAINED HEREIN IS THE PROPERTY OF TOSHIBA INDUSTRIAL PRODUCTS CANADA - THIS MUST BE KEPT IN CONFIDENCE, AND NO PART OF THIS DRAWING MAY BE REPRODUCED OR USED WITHOUT THE EXPRESS PERMISSION OF THE COMPANY.

TOSHIBA

TITLE TYPE HS MOTOR FRAME 6800
OUTLINE - TEFC/TEXP ENCLOSURE

DRAWING NO. _____ SCALE: N.T.S. SHEET: _____ OF _____

DESIGNED BY: _____ DATE: _____

CHECKED BY: N.WEST DATE: _____

DATE: _____

TOSHIBA INDUSTRIAL PRODUCTS CANADA, STONEY CREEK

E10D120

PRELIMINARY SHAFT AND MOUNTING ONLY
G.O. _____ S.O. _____ CUST. ORDER _____
CUST. _____
RATING _____
PER: _____ DATE _____
TOSHIBA INDUSTRIAL PRODUCTS CANADA, STONEY CREEK

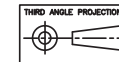

STANDARD
REVISIONS
1



Issued Date

Transmit #

Issued By

Issued Rev

TYPICAL MOTOR PERFORMANCE DATA

Model: 8004XPAL11E-C

HP	kW	Pole	FL RPM	Frame	Voltage	Hz	Phase	FL Amps
800 hp	597 kW	4	1788 rpm	6810L	4000 V	60	3	100.0 A
Enclosure	IP	Ins. Class	S.F.	Duty	NEMA Nom. Eff.	NEMA Design	kVA Code	Ambient (°C)
TEXP	55	F	1.15	Cont.	95.3	B	F	40

Load	HP	kW	Amperes	Efficiency (%)	Power Factor (%)
Full Load	800	597	100.0	95.3	90.8
¾ Load	600	447	74.3	94.9	92.1
½ Load	400	298	50.6	93.8	91.4
¼ Load	200	149			
No Load			15.0		11.3
Locked Rotor			604.4		22.3

Torque				Rotor wk ² Inertia (lb-ft ²)
Full Load (lb-ft)	Locked Rotor (% FLT)	Pull Up (% FLT)	Break Down (% FLT)	
2358	114	114	190	704

Safe Stall Time(s)		Sound Pressure dB(A) @ 1M	Bearings*		Approx. Motor Weight (lbs)
Cold	Hot		DE	NDE	
31	27	-	N222	6222-C3	11500

Motor Options:

Customer	
Customer PO	
Sales Order	
Project #	

Tag:

All characteristics are average expected values.

TOSHIBA INTERNATIONAL CORPORATION · HOUSTON, TEXAS U.S.A.

Engineering		Doc. Written By		Doc.# / Rev	
Engr. Date		Doc. Approved By		Doc. Issued	



Issued Date

Transmit #

Issued By

Issued Rev

NAMEPLATE DATA

Model: 8004XPAL11E-C

HP	kW	Pole	FL RPM	Frame	Voltage	Hz	Phase	FL Amps
800	596.552	4	1788	6810L	4000	60	3	99.97
Enclosure	IP	Ins. Class	S.F.	Duty	NEMA Nom. Eff.	NEMA Design	kVA Code	Ambient (°C)
TEXP	55	F	1.15	Cont.	95.3	B	F	40

Type: HSB

Form:

Drive End Bearing: N222

Non-Drive End Bearing: 6222-C3

Power Factor: 90.8

Max Safe RPM:

Comments 1:

Comments 2:

Comments 3:

Comments 4:

Customer

Customer PO

Sales Order

Project #

Tag:

All characteristics are average expected values.

TOSHIBA INTERNATIONAL CORPORATION · HOUSTON, TEXAS U.S.A.

Engineering	Doc. Written By	D. Suarez	Doc.# / Rev	MPCF-1120 / 0
Engr. Date	Doc. Approved By	M. Campbell	Doc. Issued	6/8/2011



Issued Date		Transmit #	
Issued By		Issued Rev	

SPEED TORQUE/CURRENT CURVE

Model: 8004XPAL11E-C

HP	kW	Pole	FL RPM	Frame	Voltage	Hz	Phase	FL Amps
800	596.552	4	1788	6810L	4000	60	3	99.97
Enclosure	IP	Ins. Class	S.F.	Duty	NEMA Nom. Eff.	NEMA Design	kVA Code	Ambient (°C)
TEXP	55	F	1.15	Cont.	95.3	B	F	40
Locked Rotor Amps	Rotor wk ² Inertia (lb-ft ²)	Torque						Break Down (%)
		Full Load (lb-ft)	Locked Rotor (%)	Pull Up (%)				
604.42	704	2357.75	113.5426911		113.5426911		190.1204962	

Design Values

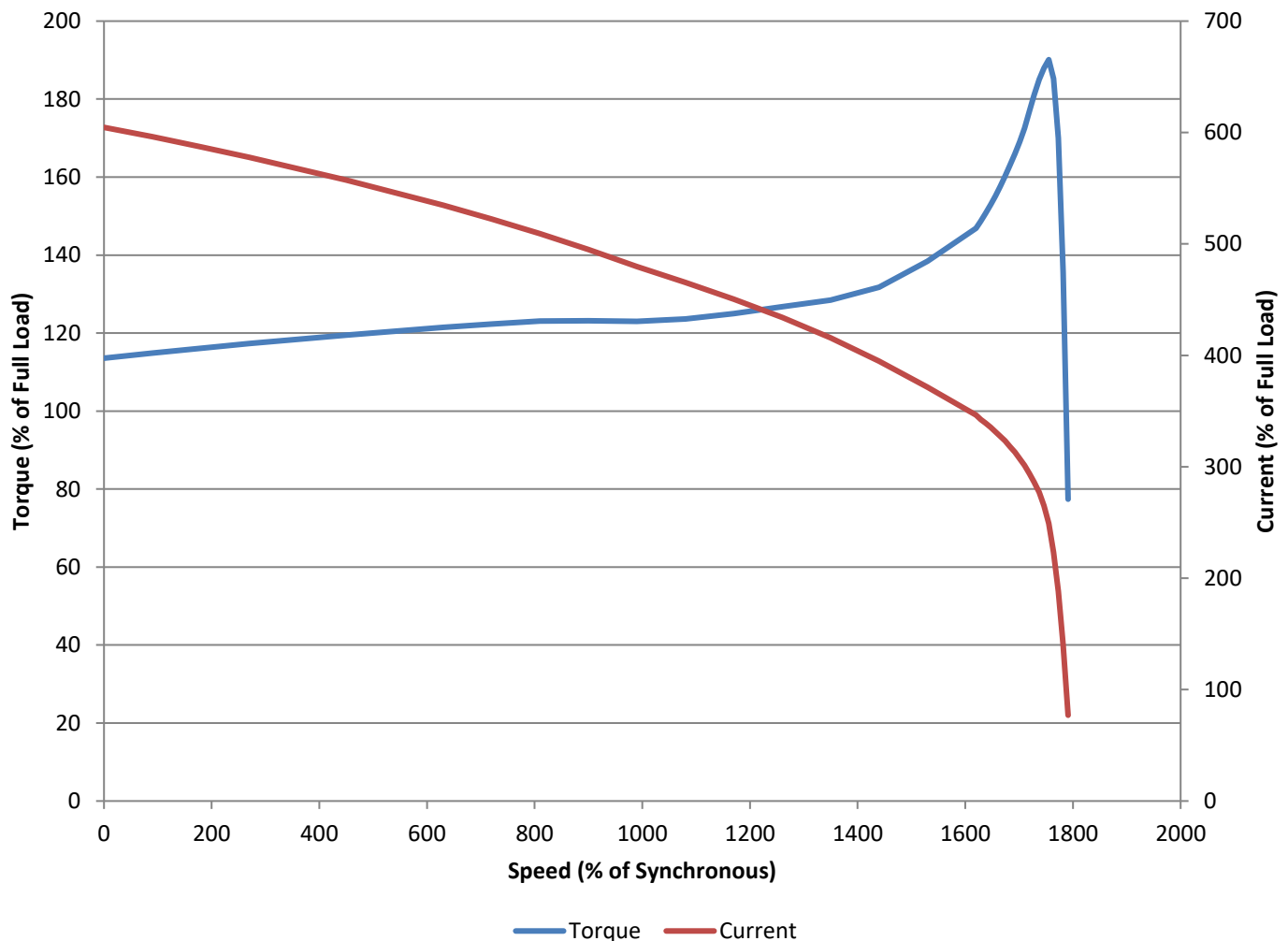

Customer		wk ² Load Inertia (lb-ft ²)		
Customer PO			Load Type	
Sales Order			Voltage (%)	100
Project #			Accel. Time	

Tag:

All characteristics are average expected values.

TOSHIBA INTERNATIONAL CORPORATION · HOUSTON, TEXAS U.S.A.

Engineering		Doc. Written By	D. Suarez	Doc.# / Rev	MPCF-1121/0
Engr. Date		Doc. Approved By	M. Campbell	Doc. Issued	6/8/2011



Issued Date

Transmit #

Issued By

Issued Rev

SPARE PARTS LIST*

Model: 8004XPAL11E-C

HP	kW	Pole	FL RPM	Frame	Voltage	Hz	Phase	FL Amps
800	596.552	4	1788	6810L	4000	60	3	99.97
Enclosure	IP	Ins. Class	S.F.	Duty	NEMA Nom. Eff.	NEMA Design	kVA Code	Ambient (°C)
TEXP	55	F	1.15	Cont.	95.3	B	F	40

Bearings DE N222

Bearings NDE 6222-C3

*Bearings are the only recommended spare part(s).

Other than the grease used for regreasable bearings and the oil used for oil-lubricated bearings, Toshiba advises that there are no "use" parts. The only insurance spares that Toshiba suggests for these squirrel-cage induction motors are industry-standard and commercially available off-the-shelf bearings as noted above.

Motor components such as terminal boxes, fan covers and other machined parts are available on special request. In these cases, please advise our order entry department of the model and serial numbers found on the motor nameplate and a description of the needed components. With this information they will be able to furnish the current part number, price and availability.

Note: Our internal part numbers are subject to change without notice and are not published.

Customer	
Customer PO	
Sales Order	
Project #	

Tag:

All characteristics are average expected values.

TOSHIBA INTERNATIONAL CORPORATION · HOUSTON, TEXAS U.S.A.

Engineering		Doc. Written By	D. Suarez	Doc.# / Rev	MPCF-1125 / 0
Engr. Date		Doc. Approved By	M. Campbell	Doc. Issued	6/8/2011