

**TECHNICAL INFORMATION**

1. BEARING LUBRICATION DE: MOBIL POLYREX EM OR EQUIVALENT  
ODE: MOBIL POLYREX EM OR EQUIVALENT
2. BEARING TYPE DE: 6328 INS  
ODE: 6328 INS
3. WINDING TEMP. DETECTORS  
NUMBER AND TYPE: 6xRTD(Pt0°C-100ohm)  
LOCATION: IN STATOR SLOT
4. BEARING TEMP. DETECTORS  
NUMBER AND TYPE: \_\_\_\_\_
5. SPACE HEATER 1 PHASE  
VOLTS: 120 WATTS: 800
6. ROTATION: CCW VIEWED FROM NON DRIVE END  
THIS MOTOR IS UNI DIRECTIONAL
7. MOTOR PAINT COLOR: GRAY
8. APPROX. WEIGHT: 14,000 Lbs
9. ACCESORIES: \_\_\_\_\_

**PRELIMINARY  
FOR QUOTATION ONLY  
DO NOT BUILD  
FROM THIS DRAWING**

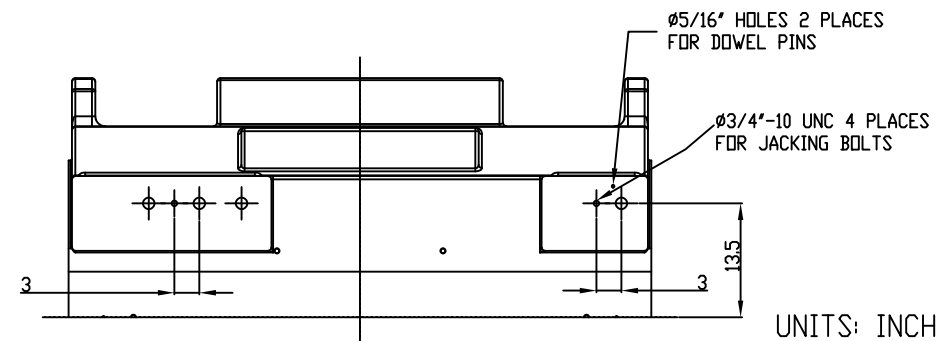
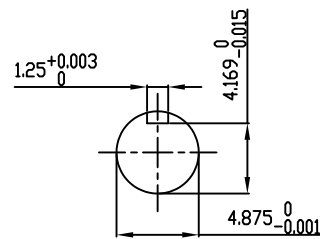

UNITS: INCHES

DRAWING LIST		NO.	REVISION	BY	DATE
MAIN TERMINAL BOX	130P-7550-68	3	CHANGE DOWEL PIN HOLE FROM 4 PLACES CHANGE AUX BOX FROM DIM 13	HL	3/17/20
AUX TERMINAL BOX FOR		2	GRS FROM SRI JACKING TO INLINE	RWS	1/2/14
SPACE HEATER	139-0052-01	1	UPDATE INLET WINDOW SIZE & MAIN T-BOX P. No., CHG. SPACE HEATER WATTS FROM 400	JMP	10/12/11
R.T.D.	139-0052-04				
THERMISTOR	N/A				
		0	FIRST ISSUE	JMP	03/01/11
PRODUCTION #	N/A				

**MOTOR OUTLINE FOR  
THREE PHASE INDUCTION MOTOR**

CUSTOMER NAME				P.O. NO.	MOTOR TAG NO.		
OUTPUT HP	POLE	VOLTAGE V	FREQUENCY Hz	FULL LOAD SPEED (min <sup>-1</sup> )	TOSHIBA MODEL NO.		
TYPE	FORM	INS. CLASS	RATING CONT.	FRAME	S.F.	ENCLOSURE	
	4	F		6810US		WP-II	
TOSHIBA INTERNATIONAL CORPORATION HOUSTON, TEXAS U.S.A.							
3rd ANGLE PROJ.	PREPARED BY:	DATE:	CHECKED BY:	DATE:	DRAWING NO.:	REV.	
	J PINON	03/01/11	B.SIDLE	03/01/11	MDSL0087-61	3	

**TYPICAL MOTOR PERFORMANCE DATA**

Model: 8008WTAL11E-C

HP	kW	Pole	FL RPM	Frame	Voltage	Hz	Phase	FL Amps
800	597	8	890	6810US	4000	60	3	108
Enclosure	IP	Ins. Class	S.F.	Duty	NEMA Nom. Eff.	NEMA Design	kVA Code	Ambient (°C)
WP-II	24	F	1.15	CONT	94.5	-		40 C

Load	HP	kW	Amperes	Efficiency (%)	Power Factor (%)
Full Load	800.00	596.6	107	94.9	84.3
¾ Load	600.00	447.4	83	94.5	82.1
½ Load	400.00	298.3	61	93.3	75.3
¼ Load	200.00	149.1	43	89.4	55.2
No Load			33.9		4.2
Locked Rotor			683		13.8

Torque				Rotor wk <sup>2</sup> Inertia (lb-ft <sup>2</sup> )
Full Load (lb-ft)	Locked Rotor (% FLT)	Pull Up (% FLT)	Break Down (% FLT)	
4726	65	75	225	1727.76

Safe Stall Time(s)		Sound Pressure dB(A) @ 1M	Bearings*		Approx. Motor Weight (lbs)
Cold	Hot		DE	NDE	
75	50	-	6328C3 INS	6328C3 INS	

\*Bearings are the only recommended spare part(s).

**Motor Options:**  
Product Family:WP-II  
Mounting:Footed,Shaft:US Shaft

Customer	
Customer PO	
Sales Order	
Project #	

Tag:

All characteristics are average expected values.

**TOSHIBA INTERNATIONAL CORPORATION · HOUSTON, TEXAS U.S.A.**

Engineering	bmammen	Doc. Written By	D. Suarez	Doc.# / Rev	MPCF-1119 / 0
Engr. Date	7/10/2014	Doc. Approved By	M. Campbell	Doc. Issued	6/8/2011

Issued Date	7/19/2021	Transmit #	
Issued By	dschoeck	Issued Rev	

**SPEED TORQUE/CURRENT CURVE**

Model: 8008WTAL11E-C

HP	kW	Pole	FL RPM	Frame	Voltage	Hz	Phase	FL Amps
800	597	8	890	6810US	4000	60	3	108
Enclosure	IP	Ins. Class	S.F.	Duty	NEMA Nom. Eff.	NEMA Design	kVA Code	Ambient (°C)
WP-II	24	F	1.15	CONT	94.5	-		40 C
Locked Rotor Amps	Rotor wk <sup>2</sup> Inertia (lb-ft <sup>2</sup> )	Torque						Break Down (%)
		Full Load (lb-ft)	Locked Rotor (%)	Pull Up (%)				
683	1727.76	4726	65	75			225	

**Design Values**

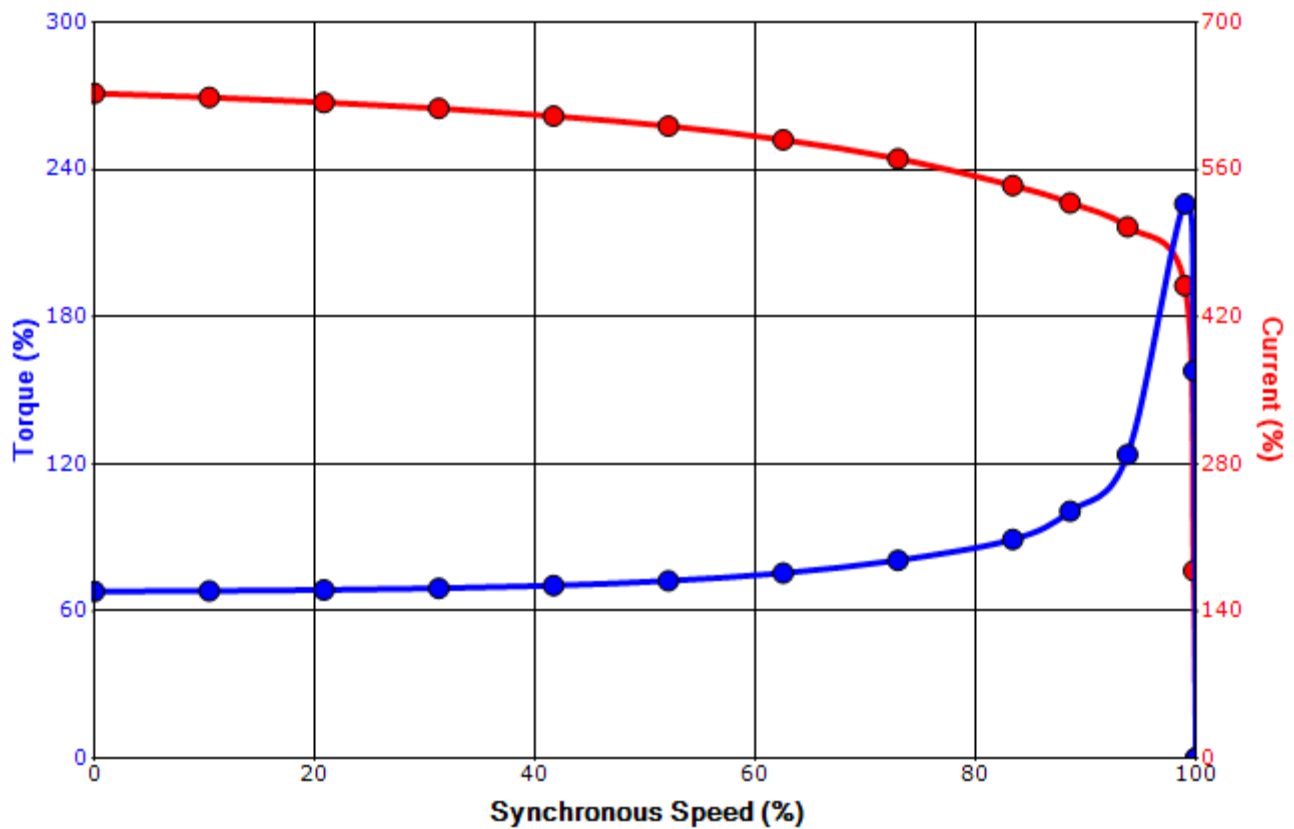

Customer		wk <sup>2</sup> Load Inertia (lb-ft <sup>2</sup> )	-
Customer PO		Load Type	-
Sales Order		Voltage (%)	100
Project #		Accel. Time	-

Tag:

All characteristics are average expected values.

**TOSHIBA INTERNATIONAL CORPORATION · HOUSTON, TEXAS U.S.A.**

Engineering	bmammen	Doc. Written By	D. Suarez	Doc.# / Rev	MPCF-1121 / 0
Engr. Date	7/10/2014	Doc. Approved By	M. Campbell	Doc. Issued	6/8/2011