

TECHNICAL INFORMATION

1. BEARING LUBRICATION DE: MOBIL POLYREX EM
ODE: MOBIL POLYREX EM
2. BEARING TYPE DE: 6326C3
ODE: 6326C3 INSULATED
3. WINDING TEMP. DETECTORS
NUMBER AND TYPE: 6xRTD(Pt0°C-100ohm)
LOCATION: IN STATOR SLOT
4. BEARING TEMP. DETECTORS
NUMBER AND TYPE: _____
5. SPACE HEATER 1 PHASE
VOLTS: 120 WATTS: 400
6. ROTATION: CCW VIEWED FROM NON DRIVE END
THIS MOTOR IS BI DIRECTIONAL
7. MOTOR PAINT COLOR: _____
8. APPROX. WEIGHT: 7300 Lbs
9. ACCESORIES: _____

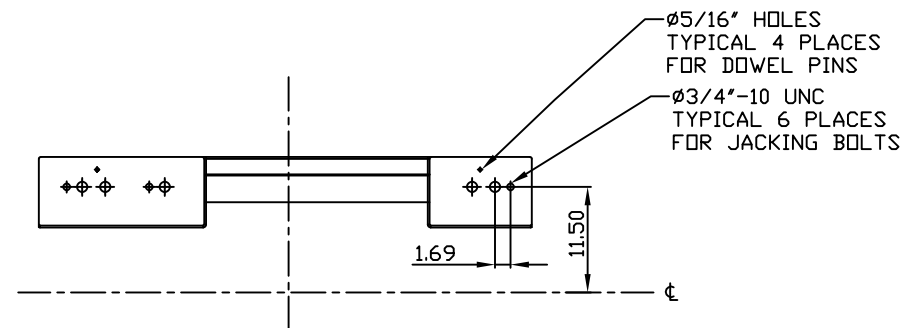
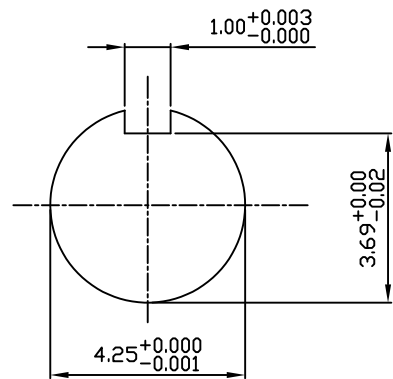

DRAWING LIST

MAIN TERMINAL BOX 130-7532-02					
AUX TERMINAL BOX FOR					
SPACE HEATER	130-7520-50				
R.T.D.	130-7522-51				
THERMISTOR	N/A				
		5	CHANGE AUX BOX DIM FROM 14.6 CHANGE JACKING BOLTS FROM 4	HL	3/16/20
PRODUCTION #	N/A	NO.	REVISION	BY	DATE

**MOTOR OUTLINE FOR
THREE PHASE INDUCTION MOTOR**

CUSTOMER NAME				P.O. NO.	MOTOR TAG NO.	
OUTPUT HP	POLE 6	VOLTAGE V	FREQUENCY Hz	FULL LOAD SPEED (min ⁻¹)	TOSHIBA MODEL NO.	
TYPE	FORM	INS. CLASS F	RATING CONT.	FRAME 5810/11/12	S.F.	ENCLOSURE WP-II
TOSHIBA INTERNATIONAL CORPORATION HOUSTON, TEXAS U.S.A.						
3rd ANGLE PROJ.	PREPARED BY: R.WILKINS	DATE: 03/25/03	CHECKED BY: M. HO	DATE: 04/01/03	DRAWING NO.:	REV.
					MDSL 0087-03	5

TYPICAL MOTOR PERFORMANCE DATA

Model: 9006WTAL11E-A

HP	kW	Pole	FL RPM	Frame	Voltage	Hz	Phase	FL Amps
900	671	6	1180	5812US	4000	60	3	123
Enclosure	IP	Ins. Class	S.F.	Duty	NEMA Nom. Eff.	NEMA Design	kVA Code	Ambient (°C)
WP-II	24	F	1.15	CONT	94.5	-		40 C

Load	HP	kW	Amperes	Efficiency (%)	Power Factor (%)
Full Load	900.00	671.1	123	94.9	83.0
¾ Load	675.00	503.3	97	94.9	78.3
½ Load	450.00	335.6	75	94.3	67.7
¼ Load	225.00	167.8	59	91.6	44.3
No Load			47.0		3.4
Locked Rotor			800		22.9

Torque				Rotor wk ² Inertia (lb-ft ²)
Full Load (lb-ft)	Locked Rotor (% FLT)	Pull Up (% FLT)	Break Down (% FLT)	
4006	150	130	220	467.14

Safe Stall Time(s)		Sound Pressure dB(A) @ 1M	Bearings*		Approx. Motor Weight (lbs)
Cold	Hot		DE	NDE	
8	2		6326C3	6326C3 INS	6865

*Bearings are the only recommended spare part(s).

Motor Options:
Product Family:WP-II
Mounting:Footed,Shaft:US Shaft

Customer	
Customer PO	
Sales Order	
Project #	

Tag:

All characteristics are average expected values.

TOSHIBA INTERNATIONAL CORPORATION · HOUSTON, TEXAS U.S.A.

Engineering	bmmammen	Doc. Written By	D. Suarez	Doc.# / Rev	MPCF-1119 / 0
Engr. Date	7/14/2014	Doc. Approved By	M. Campbell	Doc. Issued	6/8/2011

SPEED TORQUE/CURRENT CURVE

Model: 9006WTAL11E-A

HP	kW	Pole	FL RPM	Frame	Voltage	Hz	Phase	FL Amps
900	671	6	1180	5812US	4000	60	3	123
Enclosure	IP	Ins. Class	S.F.	Duty	NEMA Nom. Eff.	NEMA Design	kVA Code	Ambient (°C)
WP-II	24	F	1.15	CONT	94.5	-		40 C
Locked Rotor Amps	Rotor wk ² Inertia (lb-ft ²)	Torque						Break Down (%)
		Full Load (lb-ft)	Locked Rotor (%)	Pull Up (%)				
800	467.14	4006	150	130			220	

Design Values

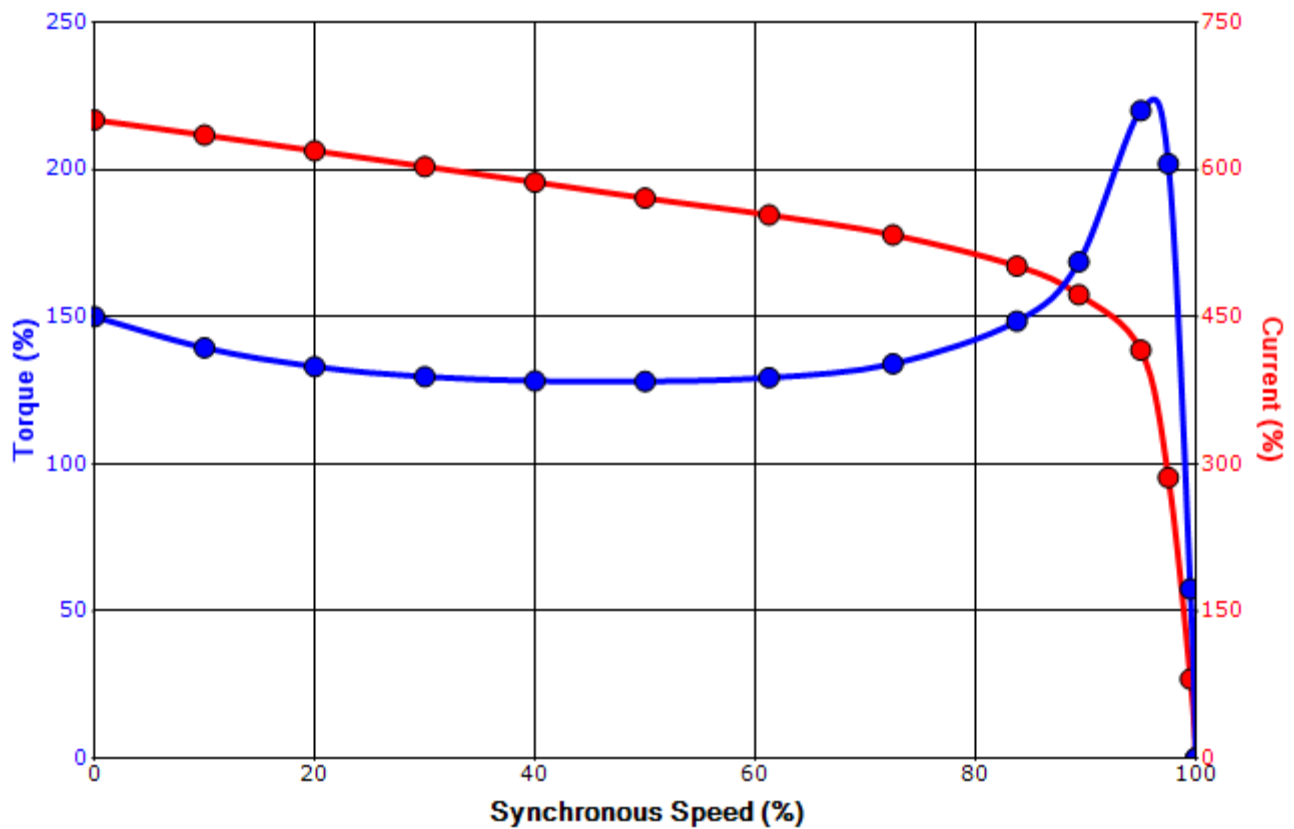

Customer		wk ² Load Inertia (lb-ft ²)	-
Customer PO		Load Type	-
Sales Order		Voltage (%)	100
Project #		Accel. Time	-

Tag:

All characteristics are average expected values.

TOSHIBA INTERNATIONAL CORPORATION · HOUSTON, TEXAS U.S.A.

Engineering	bmammen	Doc. Written By	D. Suarez	Doc.# / Rev	MPCF-1121 / 0
Engr. Date	7/14/2014	Doc. Approved By	M. Campbell	Doc. Issued	6/8/2011