

ROTATION  
UNITS  
BI-DIRECTIONAL  
SEE NOTE 5

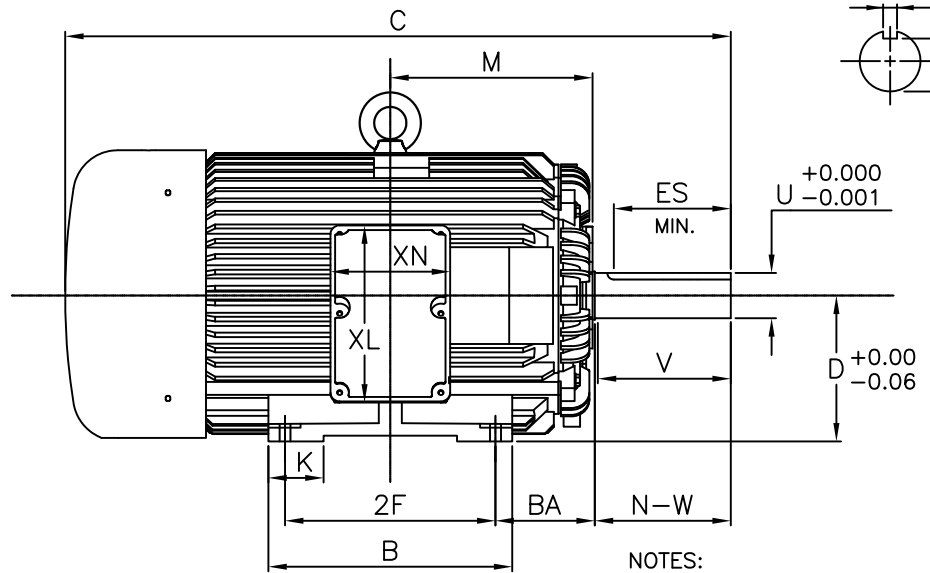
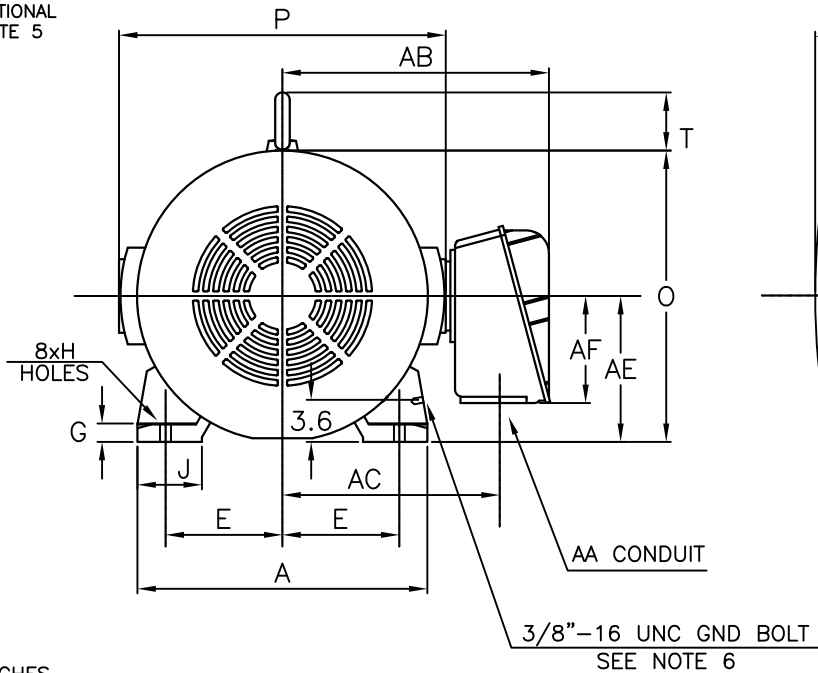

NOTES:

1. DIMENSION V REPRESENTS LENGTH OF STRAIGHT PART OF SHAFT
2. MAIN CONDUIT BOX MAY BE ROTATED IIN 90° INCREMENTS
3. KEY DIMENSIONS EQUAL S x S x 10.00 FOR UZ AND S x S x 3.00 FOR US (MOTOR SUPPLIED WITH KEY)
4. MOTOR WEIGHT SHOWN IS MAXIMUM HORSEPOWER IN FRAME
5. STANDARD PRODUCT USE BI-DIRECTIONAL FAN. OPPOSITE ROTATION AVAILABLE ONLY BY CONNECTION CHANGE
6. FRAME GROUND BOLT STANDARD ON 841 PRODUCT

UNITS: INCHES

FRAME SIZE	MOTOR DIMENSIONS											CONDUIT BOX						
	A	B	C	D	G	J	K	M	O	P	T	AA[NPT]	AB	AC	AE	AF	XL	XN
505US	24.9	20.9	50.2	12.50	1.5	5.6	4.8	17.3	24.7	28.0	5.2	4.00	22.9	18.6	12.5	9.2	15.2	10.2
505UZ	24.9	20.9	57.0	12.50	1.5	5.6	4.8	17.3	24.7	28.0	5.2	4.00	22.9	18.6	12.5	9.2	15.2	10.2

FRAME SIZE	MOUNTING				SHAFT EXTENSION			KEY SEAT			BEARINGS		MAXIMUM WEIGHT
	E	2F	H	BA	N-W	V	U	R	S	ES	LS	OS	
505US	10.00	18.00	0.94	8.5	4.75	4.50	2.875	2.450	0.750	3.00	6318C3	6318C3	4089 lbs.
505UZ	10.00	18.00	0.94	8.5	11.62	11.38	3.875	3.309	1.000	10.00	NU322C3	6318C3	4089 lbs.

CUSTOMER: \_\_\_\_\_ MOTOR MODEL NO.: \_\_\_\_\_  
 P.O. NO.: \_\_\_\_\_ HP: \_\_\_\_\_ VOLTAGE: \_\_\_\_\_ RPM(SYN.): \_\_\_\_\_ Hz: \_\_\_\_\_  
 FRAME SIZE: \_\_\_\_\_ PRODUCT TYPE: EQP III 840 & 841  
 COMMENTS: \_\_\_\_\_

TAG NO's: \_\_\_\_\_

PER: \_\_\_\_\_ DATE: \_\_\_\_\_

- STANDARD (NO AUX. BOXES)
- RTD AUX. BOX
- SPACE HEATER AUX. BOX
- BEARING RTD's

TOSHIBA RESERVES THE RIGHT TO MAKE CHANGES OF TECHNICAL IMPROVEMENT AND THE DATA MAY CHANGE WITHOUT NOTICE  PRELIMINARY

DO NOT USE FOR CONSTRUCTION, INSTALLATION, OR APPLICATION PURPOSES UNLESS THE DRAWING IS MARKED AS CERTIFIED  CERTIFIED

**TOSHIBA**

TOSHIBA INTERNATIONAL CORPORATION

TOTALLY-ENCLOSED FAN-COOLED  
HORIZONTAL FOOT-MOUNTED  
3 PHASE INDUCTION MOTOR  
F1 ASSEMBLY

**XT SERIES**

VISIT OUR WEBSITE AT:  
www.toshiba.com/ind

**TYPICAL MOTOR PERFORMANCE DATA**

Model: B2504FLF4BMHD

HP	kW	Pole	FL RPM	Frame	Voltage	Hz	Phase	FL Amps
250	186	4	1790	505UZ	460	60	3	288
Enclosure	IP	Ins. Class	S.F.	Duty	NEMA Nom. Eff.	NEMA Design	kVA Code	Ambient (°C)
TEFC	56	F	1.15	CONT	96.2	B		40 C

Load	HP	kW	Amperes	Efficiency (%)	Power Factor (%)
Full Load	250.00	186.4	287	96.1	84.7
¾ Load	187.50	139.8	226	95.2	81.4
½ Load	125.00	93.2	171	93.2	73.1
¼ Load	62.50	46.6	128	87.3	52.2
No Load			91.5		4.8
Locked Rotor			1825		39.7

Torque				Rotor wk <sup>2</sup> Inertia (lb-ft <sup>2</sup> )
Full Load (lb-ft)	Locked Rotor (% FLT)	Pull Up (% FLT)	Break Down (% FLT)	
734	285	215	285	110.37

Safe Stall Time(s)		Sound Pressure dB(A) @ 1M	Bearings*		Approx. Motor Weight (lbs)
Cold	Hot		DE	NDE	
20	8	-	NU322C3	6318C3	2907

\*Bearings are the only recommended spare part(s).

**Motor Options:**  
Product Family:EQP Global 840  
Mounting:Footed,Shaft:UZ Shaft

Customer	
Customer PO	
Sales Order	
Project #	

Tag:

All characteristics are average expected values.

**TOSHIBA INTERNATIONAL CORPORATION · HOUSTON, TEXAS U.S.A.**

Engineering	zxie	Doc. Written By	D. Suarez	Doc.# / Rev	MPCF-1119 / 0
Engr. Date	1/13/2022	Doc. Approved By	M. Campbell	Doc. Issued	6/8/2011

**SPEED TORQUE/CURRENT CURVE**

Model: B2504FLF4BMHD

HP	kW	Pole	FL RPM	Frame	Voltage	Hz	Phase	FL Amps
250	186	4	1790	505UZ	460	60	3	288
Enclosure	IP	Ins. Class	S.F.	Duty	NEMA Nom. Eff.	NEMA Design	kVA Code	Ambient (°C)
TEFC	56	F	1.15	CONT	96.2	B		40 C
Locked Rotor Amps	Rotor wk <sup>2</sup> Inertia (lb-ft <sup>2</sup> )	Torque						Break Down (%)
		Full Load (lb-ft)	Locked Rotor (%)	Pull Up (%)				
1825	110.37	734	285	215			285	

**Design Values**

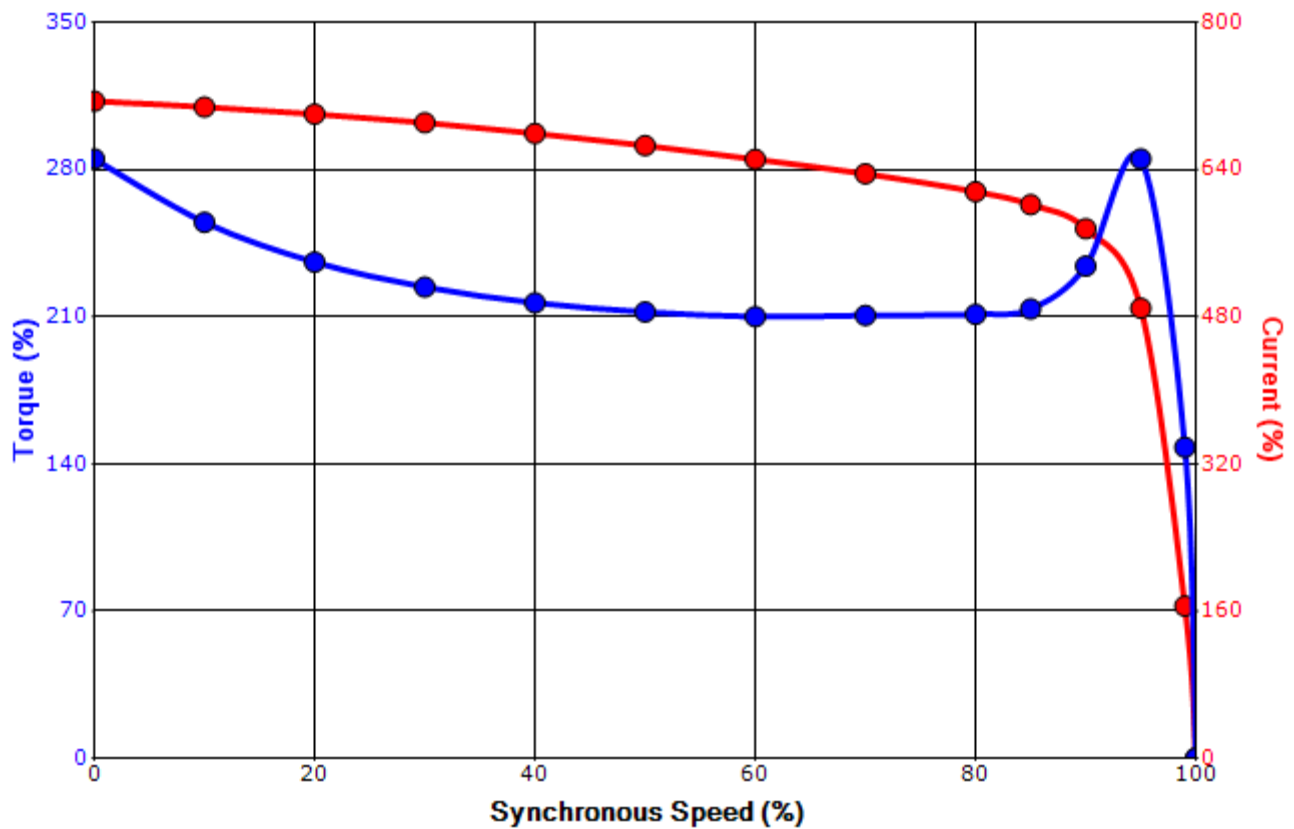

Customer		wk <sup>2</sup> Load Inertia (lb-ft <sup>2</sup> )	-
Customer PO		Load Type	-
Sales Order		Voltage (%)	100
Project #		Accel. Time	-

Tag:

All characteristics are average expected values.

**Motor Connection Diagram**  
3 Leads - Delta Connection



Switch L1 and L2 to reverse rotation

Each lead may consist of more than one cable.  
If multiple cables represent a single lead, each one  
of them will be labeled with the appropriate lead number.