

TOSHIBA/HOUSTON TOTALLY-ENCLOSED FAN-COOLED DIRECT COUPLE HORIZONTAL FOOT-MOUNTED
 Fr. N447TS-N449TS
 2 POLE

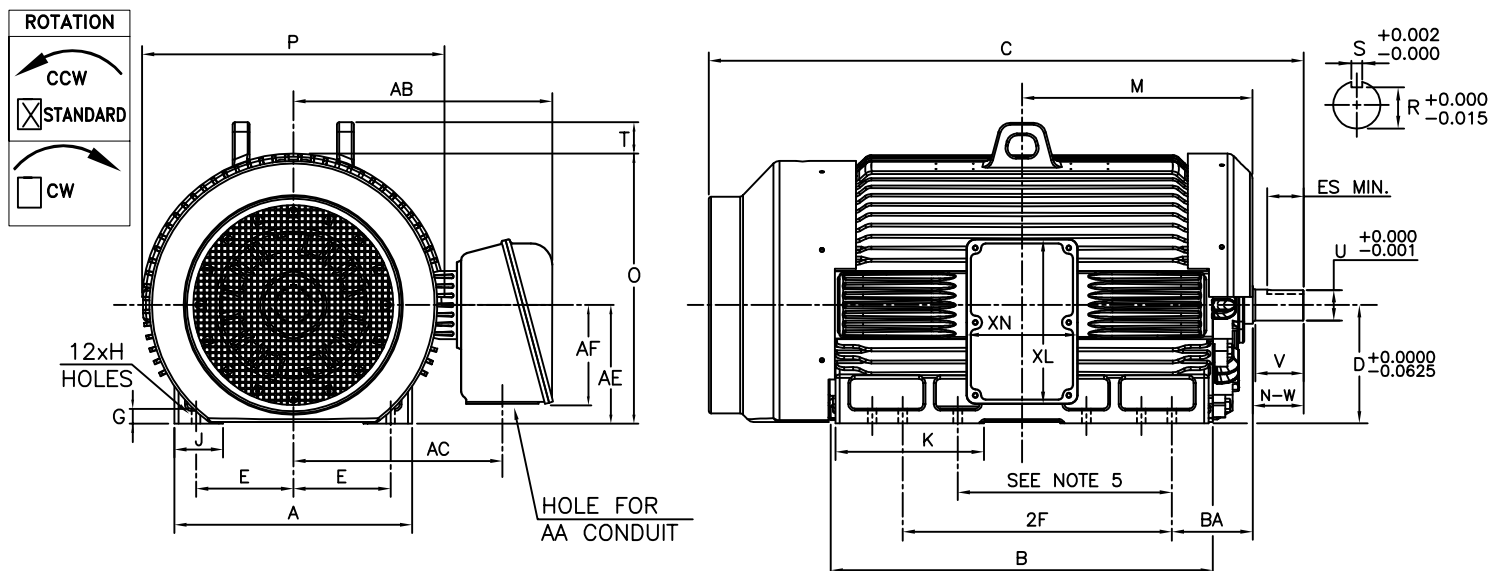

UNITS: INCHES

FRAME SIZE	MOUNTING				CONDUIT BOX						
	E	2F	H	BA	AA[NPT]	AB	AC	AE	AF	XL	XN
N447TS	9.00	20.00	0.81	7.50	4.00	24.0	19.4	11.0	9.2	15.3	10.3
N449TS	9.00	25.00	0.81	7.50	4.00	24.0	19.4	11.0	9.2	15.3	10.3

FRAME SIZE	MOTOR DIMENSIONS										
	A	B	C	D	G	J	K	M	O	P	T
N447TS	22.0	34.7	55.1	11.00	1.1	4.5	13.8	21.3	25.1	28.1	2.9
N449TS	22.0	34.7	55.1	11.00	1.1	4.5	13.8	21.3	25.1	28.1	2.9

FRAME SIZE	SHAFT EXTENSION			KEY SEAT			BEARINGS		MAXIMUM WEIGHT
	N-W	V	U	R	S	ES	LS	OS	
N447TS	4.75	4.50	2.375	2.021	0.625	3.00	6313C3	6313C3	3800 lbs.
N449TS	4.75	4.50	2.375	2.021	0.625	3.00	6313C3	6313C3	3800 lbs.

ALL DATA SUBJECT TO CHANGE WITHOUT NOTICE.
 FOR CONSTRUCTION USE ONLY CERTIFIED DATA.

CERTIFIED DATA

- NOTES:
- DIMENSION V REPRESENTS LENGTH OF STRAIGHT PART OF SHAFT.
 - CONDUIT BOX MAY BE ROTATED IN 90° INCREMENTS
 - KEY DIMENSIONS EQUAL S x S x 3.00 (MOTOR SUPPLIED WITH KEY)
 - MOTOR WEIGHT SHOWN IS MAXIMUM HORSEPOWER IN FRAME.
 - DIMENSION FOR 447 MOUNTING EQUAL (2F) LOCATED IN 447 SIDE VIEW.
 - STANDARD UNITS USE UNI-DIRECTIONAL FAN. OPPOSITE ROTATION AVAILABLE ONLY BY FAN AND CONNECTION CHANGE.

CUSTOMER: _____ P.O. NO.: _____ TAG NO.: _____
 MOTOR MODEL NO.: _____ TOSHIBA FILE NO.: _____
 HP: _____ RPM (SYN.): _____ VOLTAGE: _____ Hz: _____
 FRAME SIZE: _____ LOG NO.: _____ LOG REV. LEVEL: _____
 REMARKS: _____

 PER: _____ ISSUE DATE: _____ SUPERSEDES: _____

TYPICAL MOTOR PERFORMANCE DATA

Model: B3501FLG3BMHL

HP	kW	Pole	FL RPM	Frame	Voltage	Hz	Phase	FL Amps
350	261	2	3580	N449TS	460	60	3	382
Enclosure	IP	Ins. Class	S.F.	Duty	NEMA Nom. Eff.	NEMA Design	kVA Code	Ambient (°C)
TEFC	54	F	1.15	CONT	95.8	B		40 C

Load	HP	kW	Amperes	Efficiency (%)	Power Factor (%)
Full Load	350.00	261.0	382	95.8	89.5
¾ Load	262.50	195.7	291	94.9	88.8
½ Load	175.00	130.5	205	92.9	85.9
¼ Load	87.50	65.2	127	87.1	73.8
No Load			80.0		
Locked Rotor			2550		21.6

Torque				Rotor wk ² Inertia (lb-ft ²)
Full Load (lb-ft)	Locked Rotor (% FLT)	Pull Up (% FLT)	Break Down (% FLT)	
513	145	125	255	116.14

Safe Stall Time(s)		Sound Pressure dB(A) @ 1M	Bearings*		Approx. Motor Weight (lbs)
Cold	Hot		DE	NDE	
20	9	-	6313C3	6313C3	3850

*Bearings are the only recommended spare part(s).

Motor Options:
Product Family:EQP Global SD
Mounting:Footed,Shaft:TS Shaft

Customer	
Customer PO	
Sales Order	
Project #	

Tag:

All characteristics are average expected values.

TOSHIBA INTERNATIONAL CORPORATION · HOUSTON, TEXAS U.S.A.

Engineering	zxie	Doc. Written By	D. Suarez	Doc.# / Rev	MPCF-1119 / 0
Engr. Date	1/10/2022	Doc. Approved By	M. Campbell	Doc. Issued	6/8/2011

SPEED TORQUE/CURRENT CURVE

Model: B3501FLG3BMHL

HP	kW	Pole	FL RPM	Frame	Voltage	Hz	Phase	FL Amps
350	261	2	3580	N449TS	460	60	3	382
Enclosure	IP	Ins. Class	S.F.	Duty	NEMA Nom. Eff.	NEMA Design	kVA Code	Ambient (°C)
TEFC	54	F	1.15	CONT	95.8	B		40 C
Locked Rotor Amps	Rotor wk ² Inertia (lb-ft ²)	Torque						Break Down (%)
		Full Load (lb-ft)	Locked Rotor (%)	Pull Up (%)				
2550	116.14	513	145	125			255	

Design Values

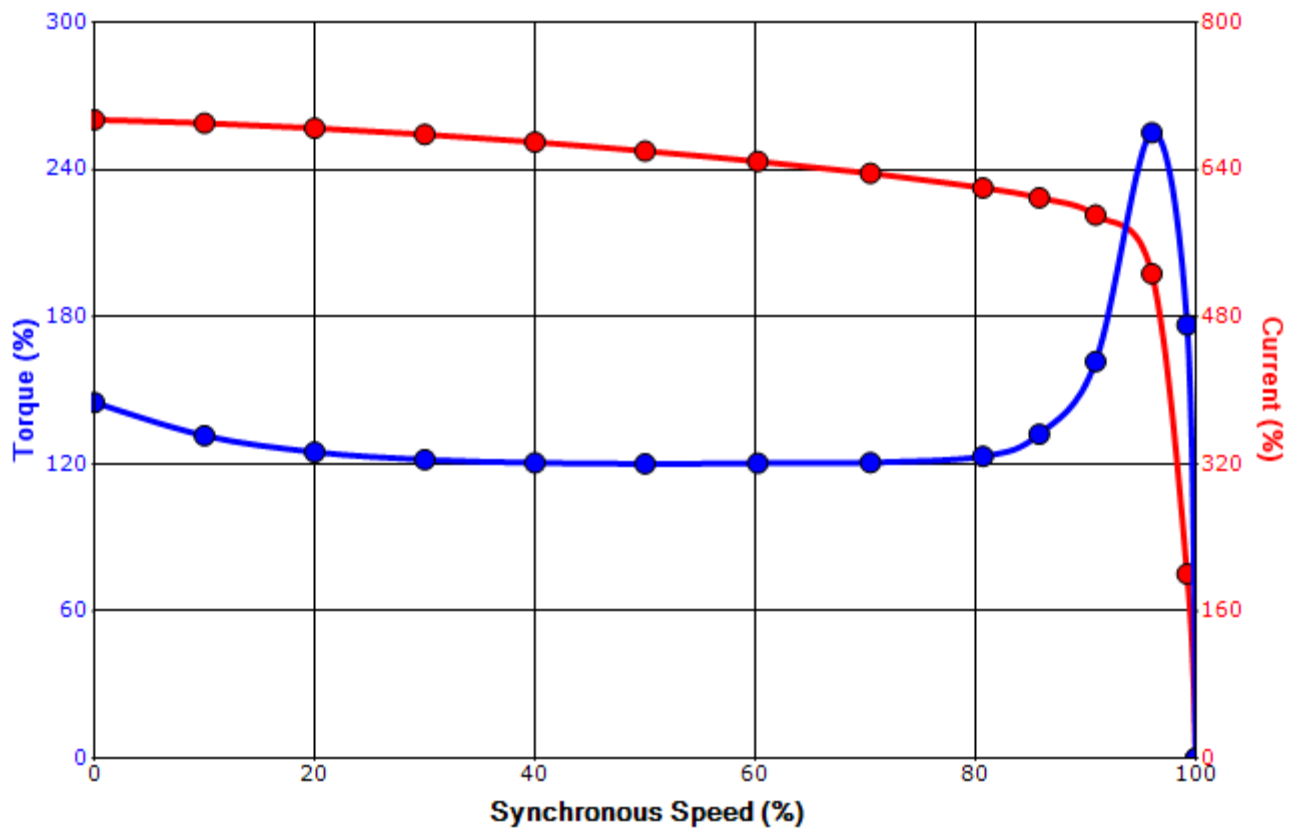

Customer		wk ² Load Inertia (lb-ft ²)	-
Customer PO		Load Type	-
Sales Order		Voltage (%)	100
Project #		Accel. Time	-

Tag:

All characteristics are average expected values.

Motor Connection Diagrams
6 Leads

Across the Line Starting / Run - Delta:



Alternate Starting Connection - Wye:



Switch L1 and L2 to reverse rotation