

TOSHIBA/HOUSTON TOTALLY-ENCLOSED FAN-COOLED HORIZONTAL FOOT-MOUNTED (O.D.E ROLLER BRG) **Fr. 5010USS**
2-POLE
350-500Hp

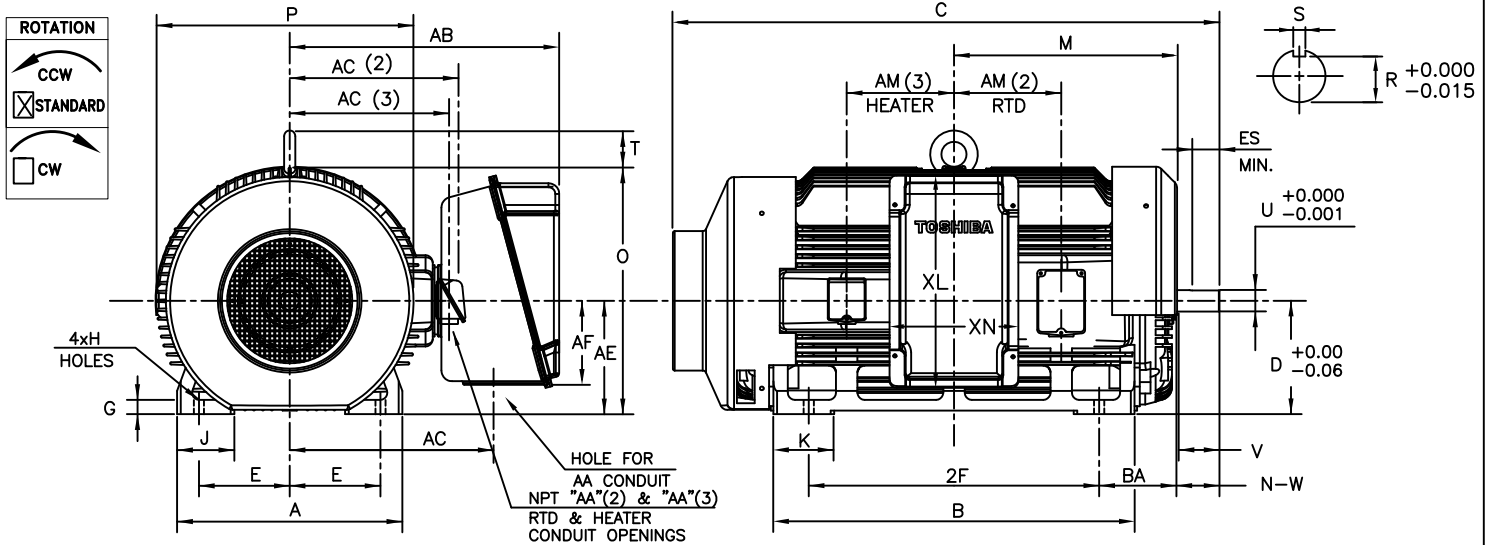

UNITS: INCHES

FRAME SIZE	MOUNTING				CONDUIT BOX						
	E	2F	H	BA	AA[NPT]	AB	AC	AE	AF	XL	XN
5010USS	10.00	32.0	1.12	8.50	4.00	29.7	22.5	12.5	9.3	23.4	14.2

FRAME SIZE	MOTOR DIMENSIONS										
	A	B	C	D	G	J	K	M	O	P	T
5010USS	24.8	39.8	60.2	12.50	1.6	6.3	6.7	24.6	27.2	28.4	4.3

FRAME SIZE	SHAFT EXTENSION			KEY SEAT			BEARINGS		MAXIMUM WEIGHT
	N-W	V	U	R	S	ES	LS	OS	
5010USS	4.75	4.50	2.375	2.021	0.625	3.03	6313C3	NU313C3	4637 lbs.

FRAME SIZE	RTD AUX. BOX					HEATER AUX. BOX				
	AA(2)	AC(2)	AE	AF(2)	AM(2)	AA(3)	AC(3)	AE	AF(3)	AM(3)
5010USS	1.5	15.58	12.5	5.1	11.8	0.75	11.3	12.5	2.56	11.81

MOTOR WITH

- AUX. RTD BOX
- AUX. HEATER BOX
- BOTH AUX. BOXES

ALL DATA SUBJECT TO CHANGE WITHOUT NOTICE.
 FOR CONSTRUCTION USE ONLY CERTIFIED DATA.

CERTIFIED DATA

NOTES:

- DIMENSION V REPRESENTS LENGTH OF STRAIGHT PART OF SHAFT.
- CONDUIT BOX MAY BE ROTATED IN 90° INCREMENTS AND MAY BE MOUNTED ON OPPOSITE SIDE ON SPECIAL ORDER.
- KEY DIMENSIONS EQUAL S x S x 3.00 (MOTOR SUPPLIED WITH KEY)
- MOTOR WEIGHT SHOWN IS MAXIMUM HORSEPOWER IN FRAME.
- STANDARD UNITS USE UNI-DIRECTIONAL FAN. OPPOSITE ROTATION AVAILABLE ONLY BY FAN AND CONNECTION CHANGE.

CUSTOMER: _____ P.O. NO.: _____ TAG NO.: _____

MOTOR MODEL NO.: _____ TOSHIBA FILE NO.: _____

HP: _____ RPM (SYN.): _____ VOLTAGE: _____ Hz: _____

FRAME SIZE: _____ LOG NO.: _____ LOG REV. LEVEL: _____

REMARKS: _____

PER: _____ ISSUE DATE: _____ SUPERSEDES: _____

TYPICAL MOTOR PERFORMANCE DATA

Model: B4001FLG8BMH

HP	kW	Pole	FL RPM	Frame	Voltage	Hz	Phase	FL Amps
400	298	2	3580	5010USS	460	60	3	434
Enclosure	IP	Ins. Class	S.F.	Duty	NEMA Nom. Eff.	NEMA Design	kVA Code	Ambient (°C)
TEFC	54	F	1.15	CONT	95.8	B		40 C

Load	HP	kW	Amperes	Efficiency (%)	Power Factor (%)
Full Load	400.00	298.3	433	96.1	89.9
¾ Load	300.00	223.7	329	95.3	89.4
½ Load	200.00	149.1	230	93.6	87.0
¼ Load	100.00	74.6	139	88.3	76.2
No Load			76.6		7.5
Locked Rotor			2900		32.3

Torque				Rotor wk ²
Full Load (lb-ft)	Locked Rotor (% FLT)	Pull Up (% FLT)	Break Down (% FLT)	Inertia (lb-ft ²)
587	225	155	220	129.14

Safe Stall Time(s)		Sound Pressure dB(A) @ 1M	Bearings*		Approx. Motor Weight (lbs)
Cold	Hot		DE	NDE	
20	8	-	6313C3	NU313C3	4050

*Bearings are the only recommended spare part(s).

Motor Options:
Product Family:EQP Global SD
Mounting:Footed,Shaft:USS Shaft

Customer	
Customer PO	
Sales Order	
Project #	

Tag:

All characteristics are average expected values.

TOSHIBA INTERNATIONAL CORPORATION · HOUSTON, TEXAS U.S.A.

Engineering	zxie	Doc. Written By	D. Suarez	Doc.# / Rev	MPCF-1119 / 0
Engr. Date	9/24/2021	Doc. Approved By	M. Campbell	Doc. Issued	6/8/2011

SPEED TORQUE/CURRENT CURVE

Model: B4001FLG8BMH

HP	kW	Pole	FL RPM	Frame	Voltage	Hz	Phase	FL Amps
400	298	2	3580	5010USS	460	60	3	434
Enclosure	IP	Ins. Class	S.F.	Duty	NEMA Nom. Eff.	NEMA Design	kVA Code	Ambient (°C)
TEFC	54	F	1.15	CONT	95.8	B		40 C
Locked Rotor Amps	Rotor wk ² Inertia (lb-ft ²)	Torque						Break Down (%)
		Full Load (lb-ft)	Locked Rotor (%)	Pull Up (%)				
2900	129.14	587	225	155			220	

Design Values

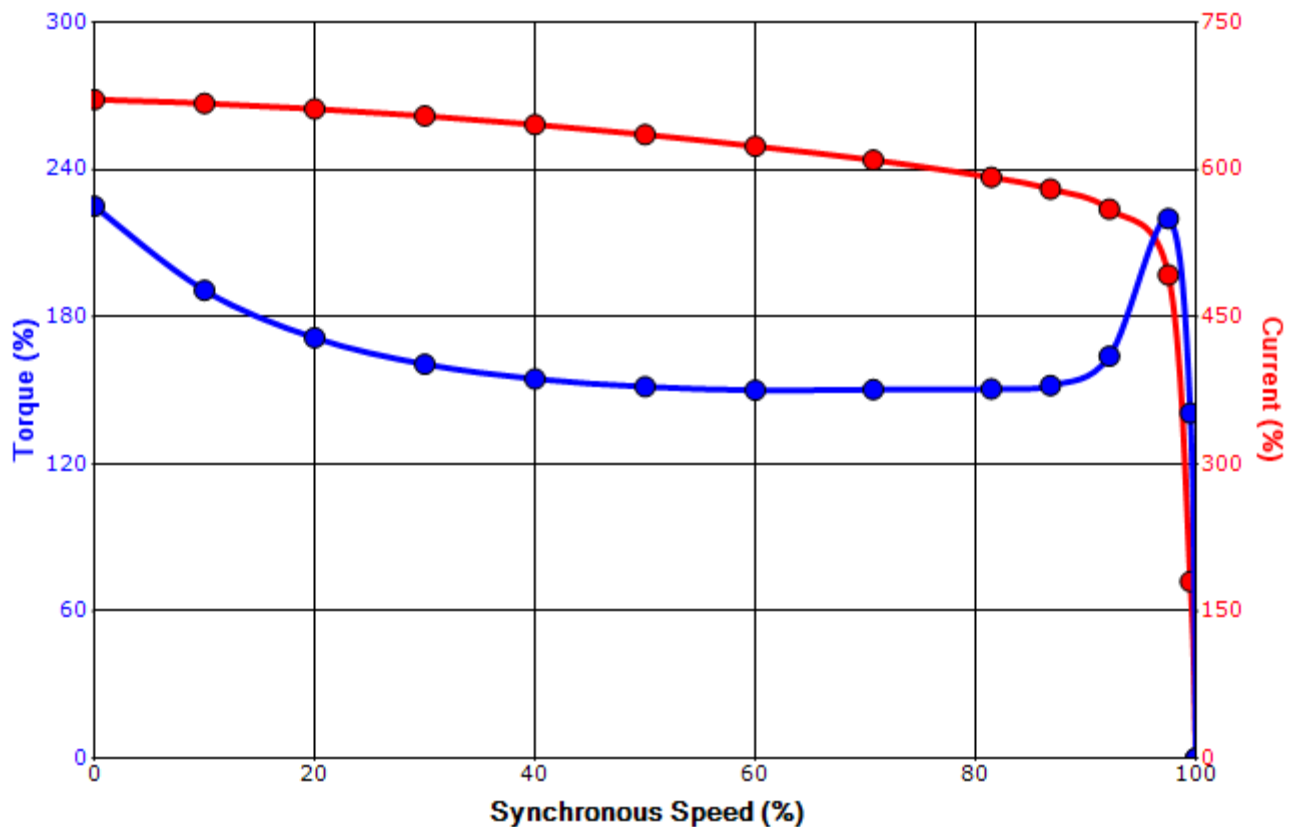

Customer		wk ² Load Inertia (lb-ft ²)	-
Customer PO		Load Type	-
Sales Order		Voltage (%)	100
Project #		Accel. Time	-

Tag:

All characteristics are average expected values.

TOSHIBA INTERNATIONAL CORPORATION · HOUSTON, TEXAS U.S.A.

Engineering	zxie	Doc. Written By	D. Suarez	Doc.# / Rev	MPCF-1121 / 0
Engr. Date	9/24/2021	Doc. Approved By	M. Campbell	Doc. Issued	6/8/2011

Motor Connection Diagram

12 Leads

Single Voltage



Switch L1 and L2 to reverse rotation