

**TECHNICAL INFORMATION**

1. BEARING LUBRICATION DE: MOBIL POLYREX EM  
ODE: MOBIL POLYREX EM
2. BEARING TYPE DE: 6326C3  
ODE: 6326C3 INSULATED
3. WINDING TEMP. DETECTORS  
NUMBER AND TYPE: 6xRTD(Pt0°C-100ohm)  
LOCATION: IN STATOR SLOT
4. BEARING TEMP. DETECTORS  
NUMBER AND TYPE: \_\_\_\_\_
5. SPACE HEATER 1 PHASE  
VOLTS: 120 WATTS: 400
6. ROTATION: CCW VIEWED FROM NON DRIVE END  
THIS MOTOR IS BI DIRECTIONAL
7. MOTOR PAINT COLOR: \_\_\_\_\_
8. APPROX. WEIGHT: 7300 Lbs
9. ACCESORIES: \_\_\_\_\_

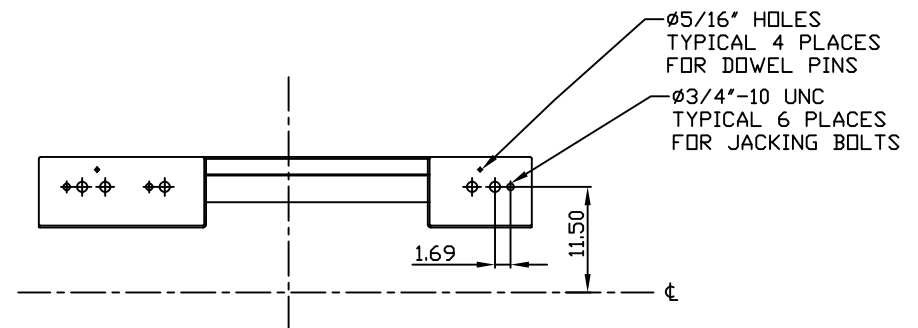
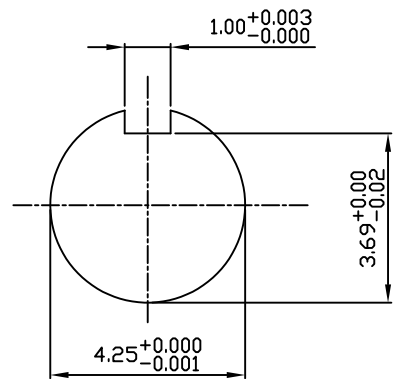

**DRAWING LIST**

MAIN TERMINAL BOX 130-7532-02					
AUX TERMINAL BOX FOR					
SPACE HEATER	130-7520-50				
R.T.D.	130-7522-51				
THERMISTOR	N/A				
		5	CHANGE AUX BOX DIM FROM 14.6 CHANGE JACKING BOLTS FROM 4	HL	3/16/20
PRODUCTION #	N/A	NO.	REVISION	BY	DATE

**MOTOR OUTLINE FOR  
THREE PHASE INDUCTION MOTOR**

CUSTOMER NAME				P.O. NO.	MOTOR TAG NO.	
OUTPUT HP	POLE 6	VOLTAGE V	FREQUENCY Hz	FULL LOAD SPEED (min <sup>-1</sup> )	TOSHIBA MODEL NO.	
TYPE	FORM	INS. CLASS F	RATING CONT.	FRAME 5810/11/12	S.F.	ENCLOSURE WP-II
TOSHIBA INTERNATIONAL CORPORATION HOUSTON, TEXAS U.S.A.						
3rd ANGLE PROJ.	PREPARED BY: R.WILKINS	DATE: 03/25/03	CHECKED BY: M. HO	DATE: 04/01/03	DRAWING NO.:	REV.
					MDSL 0087-03	5

**TYPICAL MOTOR PERFORMANCE DATA**

Model: M206WTAL11E-C

HP	kW	Pole	FL RPM	Frame	Voltage	Hz	Phase	FL Amps
1000	746	6	1190	5812US	4000	60	3	125
Enclosure	IP	Ins. Class	S.F.	Duty	NEMA Nom. Eff.	NEMA Design	kVA Code	Ambient (°C)
WP-II	24	F	1.15	CONT	94.5	-		40 C

Load	HP	kW	Amperes	Efficiency (%)	Power Factor (%)
Full Load	1000.00	745.7	125	94.9	90.8
¾ Load	750.00	559.3	95	94.4	89.8
½ Load	500.00	372.9	67	92.9	85.8
¼ Load	250.00	186.4	43	87.9	70.6
No Load			25.8		10.3
Locked Rotor			792		25.5

Torque				Rotor wk <sup>2</sup> Inertia (lb-ft <sup>2</sup> )
Full Load (lb-ft)	Locked Rotor (% FLT)	Pull Up (% FLT)	Break Down (% FLT)	
4421	145	150	225	1068.77

Safe Stall Time(s)		Sound Pressure dB(A) @ 1M	Bearings*		Approx. Motor Weight (lbs)
Cold	Hot		DE	NDE	
42	28	-	6326C3	6326C3 INS	

\*Bearings are the only recommended spare part(s).

**Motor Options:**  
Product Family:WP-II  
Mounting:Footed,Shaft:US Shaft

Customer	
Customer PO	
Sales Order	
Project #	

Tag:

All characteristics are average expected values.

**TOSHIBA INTERNATIONAL CORPORATION · HOUSTON, TEXAS U.S.A.**

Engineering	bammen	Doc. Written By	D. Suarez	Doc.# / Rev	MPCF-1119 / 0
Engr. Date	7/10/2014	Doc. Approved By	M. Campbell	Doc. Issued	6/8/2011

**SPEED TORQUE/CURRENT CURVE**

Model: M206WTAL11E-C

HP	kW	Pole	FL RPM	Frame	Voltage	Hz	Phase	FL Amps
1000	746	6	1190	5812US	4000	60	3	125
Enclosure	IP	Ins. Class	S.F.	Duty	NEMA Nom. Eff.	NEMA Design	kVA Code	Ambient (°C)
WP-II	24	F	1.15	CONT	94.5	-		40 C
Locked Rotor Amps	Rotor wk <sup>2</sup> Inertia (lb-ft <sup>2</sup> )	Torque						Break Down (%)
		Full Load (lb-ft)	Locked Rotor (%)	Pull Up (%)				
792	1068.77	4421	145	150			225	

**Design Values**

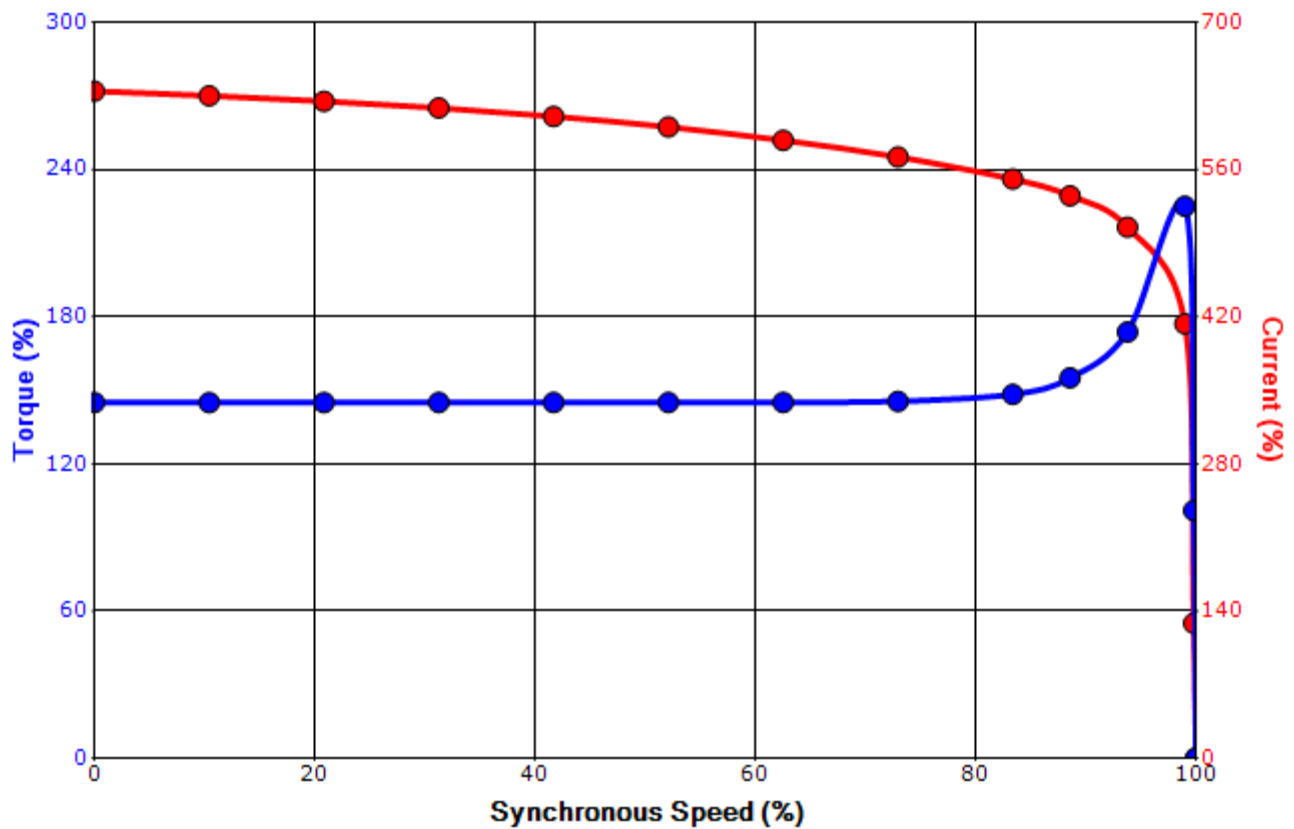

Customer		wk <sup>2</sup> Load Inertia (lb-ft <sup>2</sup> )	-
Customer PO		Load Type	-
Sales Order		Voltage (%)	100
Project #		Accel. Time	-

Tag:

All characteristics are average expected values.

**TOSHIBA INTERNATIONAL CORPORATION · HOUSTON, TEXAS U.S.A.**

Engineering	bmammen	Doc. Written By	D. Suarez	Doc.# / Rev	MPCF-1121 / 0
Engr. Date	7/10/2014	Doc. Approved By	M. Campbell	Doc. Issued	6/8/2011