

TECHNICAL INFORMATION

1. BEARING LUBRICATION DE: TURBINE OIL ISO VG32
ODE: TURBINE OIL ISO VG32
2. BEARING TYPE DE: M11-125 INS
ODE: M11-125 INS
3. WINDING TEMP. DETECTORS
NUMBER AND TYPE: 6xRTD(Pt0°C-100ohm)
LOCATION: IN STATOR SLOT
4. BEARING TEMP. DETECTORS
NUMBER AND TYPE: _____
5. SPACE HEATER 1 PHASE
VOLTS: 120 WATTS: 800
6. ROTATION: CCW VIEWED FROM NON DRIVE END
THIS MOTOR IS BI DIRECTIONAL
7. MOTOR PAINT COLOR: GRAY
8. APPROX. WEIGHT: 14,000 Lbs
9. ACCESORIES:

**PRELIMINARY
FOR QUOTATION ONLY
DO NOT BUILD
FROM THIS DRAWING**

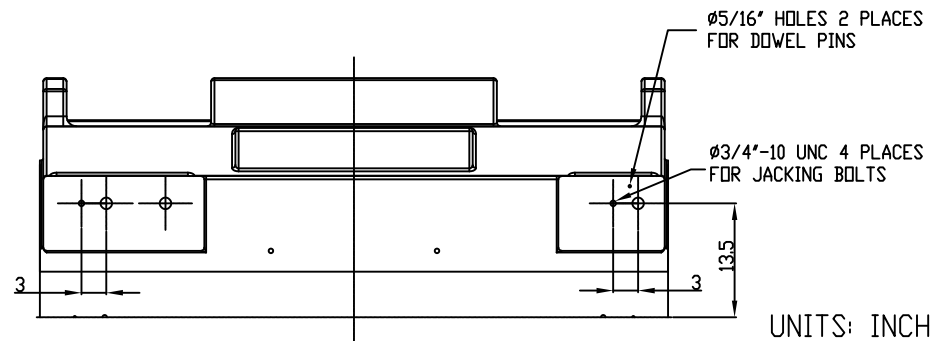
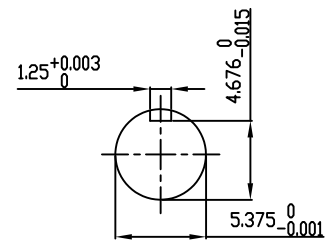

UNITS: INCHES

DRAWING LIST	
MAIN TERMINAL BOX 130P-7550-68	
AUX TERMINAL BOX FOR	
SPACE HEATER	130-7520-50
R.T.D.	130-7522-51
THERMISTOR	N/A
PRODUCTION #	N/A

4	CHANGE DOWEL PIN HOLE FROM 4 PLACES CHANGE AUX BOX DIM FROM 13	HL	3/19/20
3	JACKING TO INLINE	RWS	1/3/14
2	UPDATE TOP HAT EXHAUST WINDOWS	JMP	03/01/12
1	CHG. SPACE HEATER WATTS FROM 400	JMP	10/12/11
0	FIRST ISSUE	JMP	10/04/11
NO.	REVISION	BY	DATE

MOTOR OUTLINE FOR THREE PHASE INDUCTION MOTOR						
CUSTOMER NAME			P.O. NO.		MOTOR TAG NO.	
OUTPUT HP	POLE 8	VOLTAGE V	FREQUENCY Hz	FULL LOAD SPEED (min ⁻¹)	TOSHIBA MODEL NO.	
TYPE	FORM	INS. CLASS F	RATING CONT.	FRAME 6813US	S.F.	ENCLOSURE WP-II
TOSHIBA INTERNATIONAL CORPORATION HOUSTON, TEXAS U.S.A.						
3rd ANGLE PROJ.	PREPARED BY: J.PINON	DATE: 10/04/11	CHECKED BY: B SIDLE	DATE: 10/4/11	DRAWING NO.:	REV.
					MDSL0087-71	4

TYPICAL MOTOR PERFORMANCE DATA

Model: M208WTQL11E-C

HP	kW	Pole	FL RPM	Frame	Voltage	Hz	Phase	FL Amps
1000	746	8	890	6813US	4000	60	3	134
Enclosure	IP	Ins. Class	S.F.	Duty	NEMA Nom. Eff.	NEMA Design	kVA Code	Ambient (°C)
WP-II	24	F	1.15	CONT	95.0	-		40 C

Load	HP	kW	Amperes	Efficiency (%)	Power Factor (%)
Full Load	1000.00	745.7	133	95.2	84.4
¾ Load	750.00	559.3	103	94.9	82.1
½ Load	500.00	372.9	76	93.8	75.3
¼ Load	250.00	186.4	54	90.1	55.1
No Load			42.2		3.9
Locked Rotor			869		13.3

Torque				Rotor wk ² Inertia (lb-ft ²)
Full Load (lb-ft)	Locked Rotor (% FLT)	Pull Up (% FLT)	Break Down (% FLT)	
5908	65	75	225	2083.08

Safe Stall Time(s)		Sound Pressure dB(A) @ 1M	Bearings*		Approx. Motor Weight (lbs)
Cold	Hot		DE	NDE	
68	44		M11-125 INS	M11-125 INS	14000

*Bearings are the only recommended spare part(s).

Motor Options:
Mounting:Footed,Shaft:US Shaft

Customer	
Customer PO	
Sales Order	
Project #	

Tag:

All characteristics are average expected values.

TOSHIBA INTERNATIONAL CORPORATION · HOUSTON, TEXAS U.S.A.

Engineering	bmammen	Doc. Written By	D. Suarez	Doc.# / Rev	MPCF-1119 / 0
Engr. Date	6/18/2014	Doc. Approved By	M. Campbell	Doc. Issued	6/8/2011

Issued Date	7/19/2021	Transmit #	
Issued By	dschoeck	Issued Rev	

SPEED TORQUE/CURRENT CURVE

Model: M208WTQL11E-C

HP	kW	Pole	FL RPM	Frame	Voltage	Hz	Phase	FL Amps
1000	746	8	890	6813US	4000	60	3	134
Enclosure	IP	Ins. Class	S.F.	Duty	NEMA Nom. Eff.	NEMA Design	kVA Code	Ambient (°C)
WP-II	24	F	1.15	CONT	95.0	-		40 C
Locked Rotor Amps	Rotor wk ² Inertia (lb-ft ²)	Torque						Break Down (%)
		Full Load (lb-ft)	Locked Rotor (%)	Pull Up (%)				
869	2083.08	5908	65	75			225	

Design Values

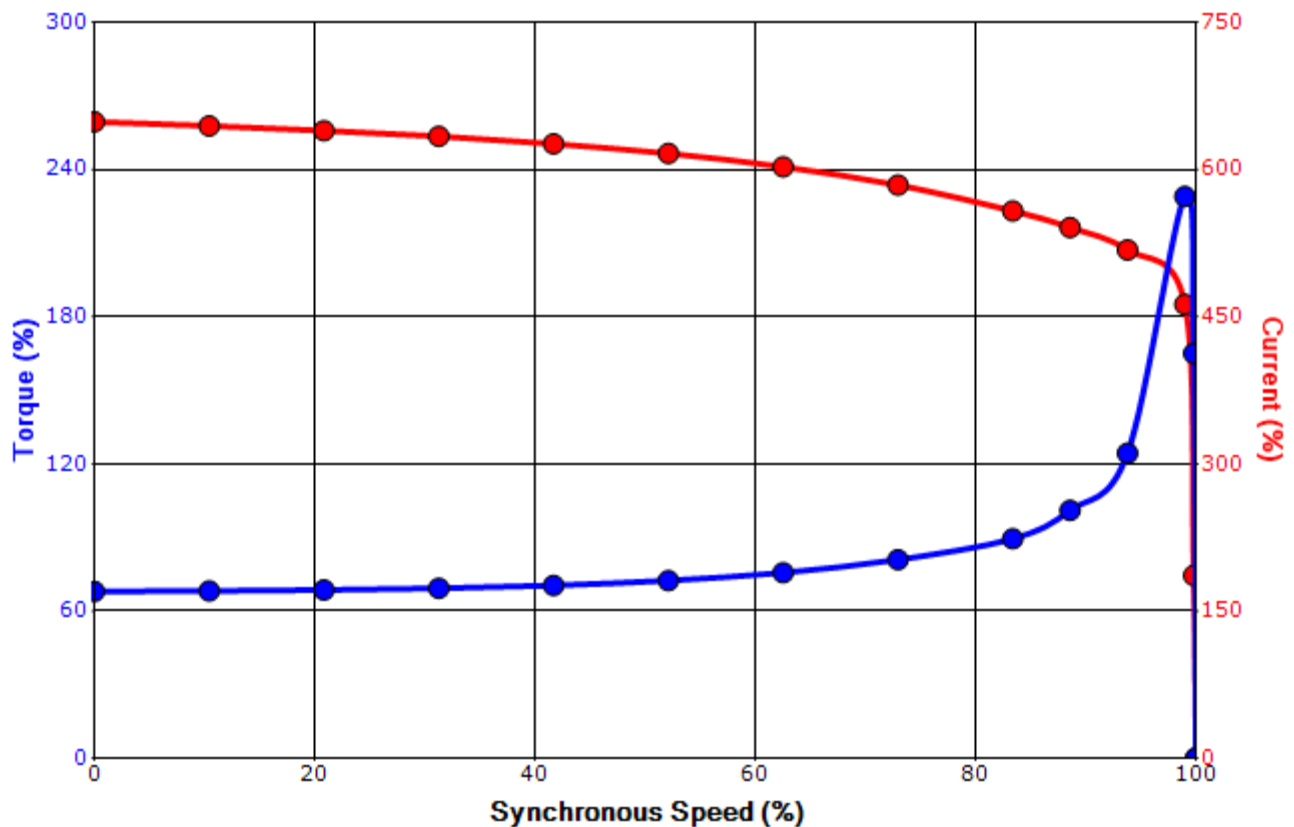

Customer		wk ² Load Inertia (lb-ft ²)	-
Customer PO		Load Type	-
Sales Order		Voltage (%)	100
Project #		Accel. Time	-

Tag:

All characteristics are average expected values.