

TECHNICAL INFORMATION

1. BEARING LUBRICATION DE: TURBINE OIL ISO VG32
ODE: TURBINE OIL ISO VG32
2. BEARING TYPE DE: M11-125 INS
ODE: M11-125 INS
3. WINDING TEMP. DETECTORS
NUMBER AND TYPE: 6xRTD(Pt0°C-100ohm)
LOCATION: IN STATOR SLOT
4. BEARING TEMP. DETECTORS
NUMBER AND TYPE: _____
5. SPACE HEATER 1 PHASE
VOLTS: 120 WATTS: 800
6. ROTATION: CCW VIEWED FROM NON DRIVE END
THIS MOTOR IS UNI DIRECTIONAL
7. MOTOR PAINT COLOR: GRAY
8. APPROX. WEIGHT: 14,000 Lbs
9. ACCESORIES:

**PRELIMINARY
FOR QUOTATION ONLY
DO NOT BUILD
FROM THIS DRAWING**

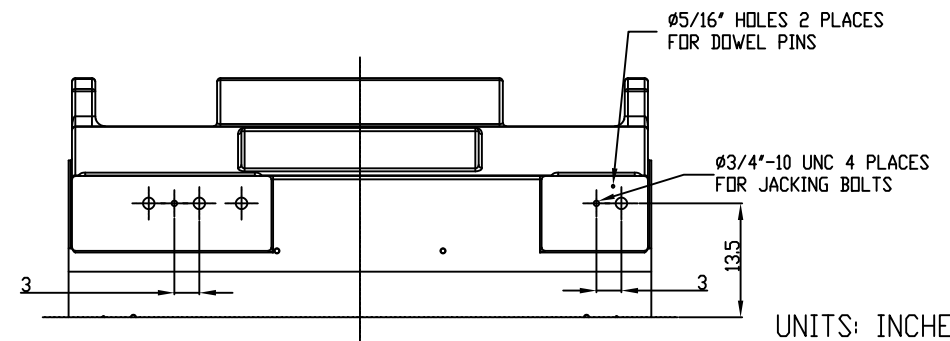
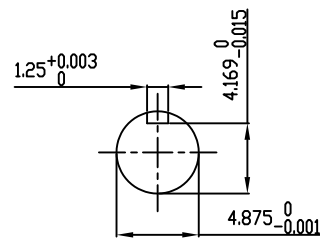

UNITS: INCHES

DRAWING LIST		NO.	REVISION	BY	DATE
MAIN TERMINAL BOX	130P-7550-68	3	CHANGE DOWEL PIN HOLE FROM 4 PLACES CHANGE AUX BOX DIM FROM 13	HL	3/18/20
AUX TERMINAL BOX FOR		2	JACKING TO INLINE	RWS	1/3/14
SPACE HEATER	139-0052-01	1	UPDATE INLET WINDOW SIZE & MAIN T-BOX P. No., CHG. SPACE HEATER WATTS FROM 400	JMP	10/12/11
R.T.D.	139-0052-04				
THERMISTOR	N/A				
		0	FIRST ISSUE	BCS	11/10/10
PRODUCTION #	N/A				

**MOTOR OUTLINE FOR
THREE PHASE INDUCTION MOTOR**

CUSTOMER NAME				P.O. NO.	MOTOR TAG NO.	
OUTPUT HP	POLE	VOLTAGE V	FREQUENCY Hz	FULL LOAD SPEED (min ⁻¹)	TOSHIBA MODEL NO.	
TYPE	FORM	INS. CLASS	RATING CONT.	FRAME	S.F.	ENCLOSURE
	4	F		6810US		WP-II
TOSHIBA INTERNATIONAL CORPORATION HOUSTON, TEXAS U.S.A.						
3rd ANGLE PROJ.	PREPARED BY:	DATE:	CHECKED BY:	DATE:	DRAWING NO.:	REV.
	B SIDLE	11/10/10	J.PINON	11/10/10	MDSL0087-66	3

TYPICAL MOTOR PERFORMANCE DATA

Model: M405WTQL11E-C

HP	kW	Pole	FL RPM	Frame	Voltage	Hz	Phase	FL Amps
2000	1492	4	1780	6810US	4000	60	3	249
Enclosure	IP	Ins. Class	S.F.	Duty	NEMA Nom. Eff.	NEMA Design	kVA Code	Ambient (°C)
WP-II	24	F	1.15	CONT	96.2	-		40 C

Load	HP	kW	Amperes	Efficiency (%)	Power Factor (%)
Full Load	2000.00	1491.4	249	96.3	89.7
¾ Load	1500.00	1118.6	189	96.1	88.8
½ Load	1000.00	745.7	133	95.5	84.5
¼ Load	500.00	372.9	85	92.7	67.8
No Load			50.6		4.4
Locked Rotor			1596		14.7

Torque				Rotor wk ² Inertia (lb-ft ²)
Full Load (lb-ft)	Locked Rotor (% FLT)	Pull Up (% FLT)	Break Down (% FLT)	
5898	75	80	240	930.28

Safe Stall Time(s)		Sound Pressure dB(A) @ 1M	Bearings*		Approx. Motor Weight (lbs)
Cold	Hot		DE	NDE	
35	15		M11-125 INS	M11-125 INS	14000

*Bearings are the only recommended spare part(s).

Motor Options:
Product Family:WP-II
Mounting:Footed,Shaft:US Shaft

Customer	
Customer PO	
Sales Order	
Project #	

Tag:

All characteristics are average expected values.

TOSHIBA INTERNATIONAL CORPORATION · HOUSTON, TEXAS U.S.A.

Engineering	bammen	Doc. Written By	D. Suarez	Doc.# / Rev	MPCF-1119 / 0
Engr. Date	7/10/2014	Doc. Approved By	M. Campbell	Doc. Issued	6/8/2011

Issued Date	7/19/2021	Transmit #	
Issued By	dschoeck	Issued Rev	

SPEED TORQUE/CURRENT CURVE

Model: M405WTQL11E-C

HP	kW	Pole	FL RPM	Frame	Voltage	Hz	Phase	FL Amps
2000	1492	4	1780	6810US	4000	60	3	249
Enclosure	IP	Ins. Class	S.F.	Duty	NEMA Nom. Eff.	NEMA Design	kVA Code	Ambient (°C)
WP-II	24	F	1.15	CONT	96.2	-		40 C
Locked Rotor Amps	Rotor wk ² Inertia (lb-ft ²)	Torque						
		Full Load (lb-ft)	Locked Rotor (%)	Pull Up (%)	Break Down (%)			
1596	930.28	5898	75	80	240			

Design Values

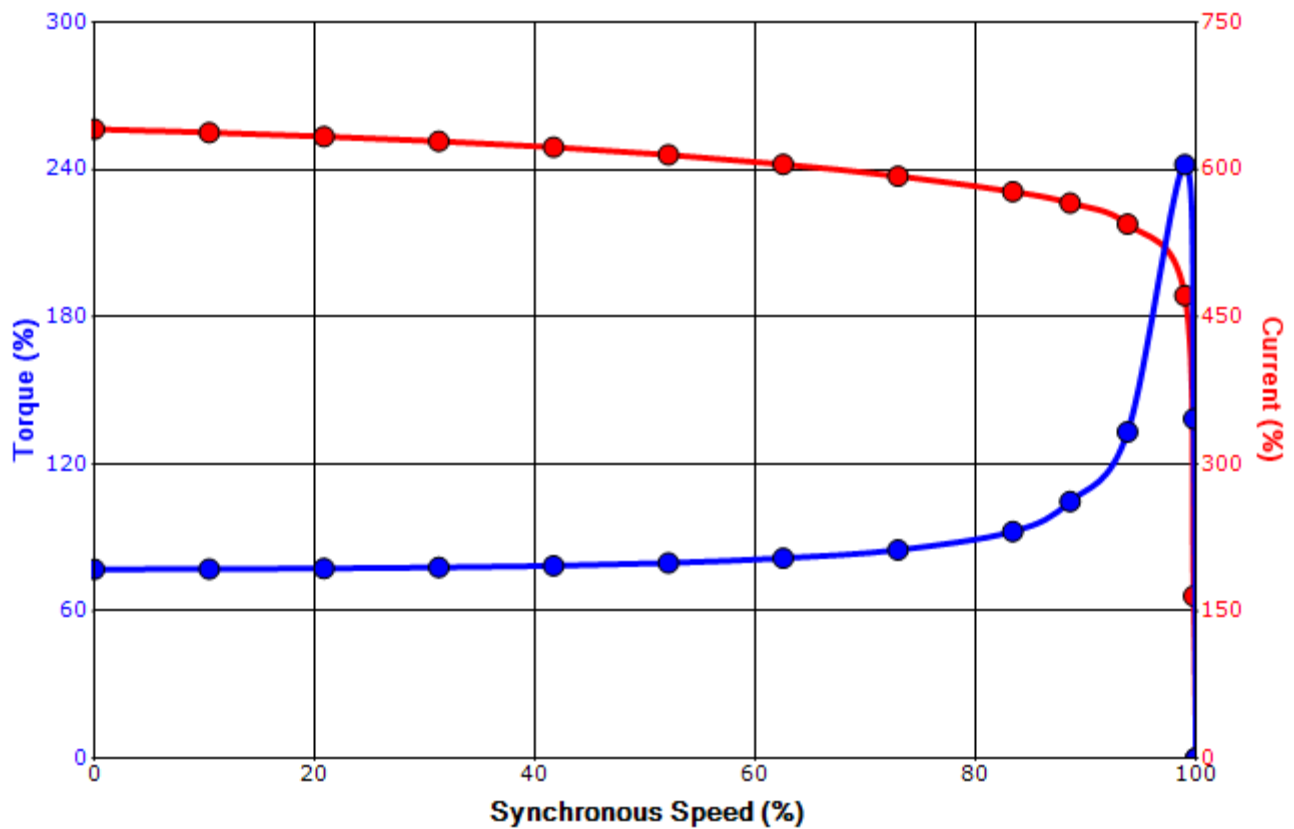

Customer		wk ² Load Inertia (lb-ft ²)	-
Customer PO		Load Type	-
Sales Order		Voltage (%)	100
Project #		Accel. Time	-

Tag:

All characteristics are average expected values.

TOSHIBA INTERNATIONAL CORPORATION · HOUSTON, TEXAS U.S.A.

Engineering	bmammen	Doc. Written By	D. Suarez	Doc.# / Rev	MPCF-1121 / 0
Engr. Date	7/10/2014	Doc. Approved By	M. Campbell	Doc. Issued	6/8/2011