

TECHNICAL INFORMATION

1. BEARING LUBRICATION DE: TURBINE OIL ISO VG32
ODE: TURBINE OIL ISO VG32
2. BEARING TYPE DE: M9-90 INS
ODE: M9-90 INS
3. WINDING TEMP. DETECTORS
NUMBER AND TYPE: 6xRTD(Pt0°C-100ohm)
LOCATION: IN STATOR SLOT
4. BEARING TEMP. DETECTORS
NUMBER AND TYPE: _____
5. SPACE HEATER 1 PHASE
VOLTS: 120 WATTS: 800
6. ROTATION: CCW VIEWED FROM NON DRIVE END
THIS MOTOR IS UNI DIRECTIONAL
7. MOTOR PAINT COLOR: GRAY
8. APPROX. WEIGHT: 12,500 Lbs
9. ACCESORIES:

**PRELIMINARY
FOR QUOTATION ONLY
DO NOT BUILD
FROM THIS DRAWING**

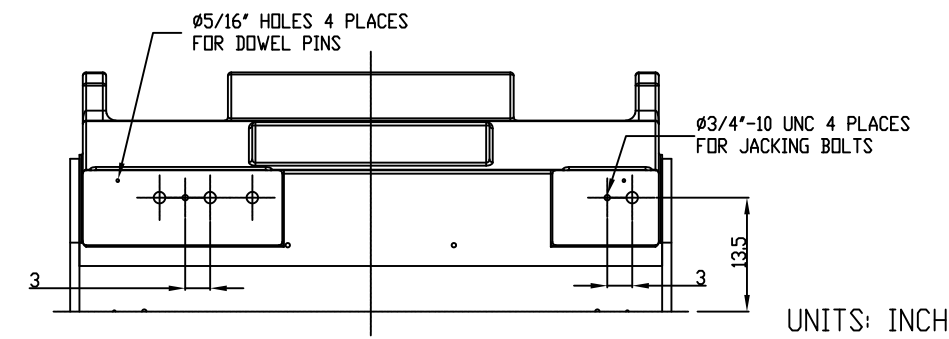
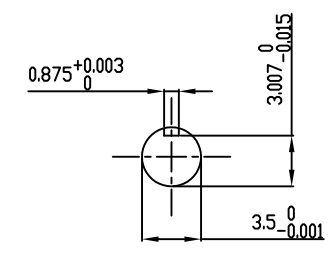

UNITS: INCHES

DRAWING LIST	
MAIN TERMINAL BOX	130P-7550-68
AUX TERMINAL BOX FOR	
SPACE HEATER	130-7520-50
R.T.D.	130-7522-51
THERMISTOR	N/A
PRODUCTION #	N/A

0	FIRST ISSUE	RC	06/16/14
NO.	REVISION	BY	DATE

MOTOR OUTLINE FOR THREE PHASE INDUCTION MOTOR						
CUSTOMER NAME			P.O. NO.		MOTOR TAG NO.	
OUTPUT HP	POLE 2	VOLTAGE V	FREQUENCY Hz	FULL LOAD SPEED (min ⁻¹)	TOSHIBA MODEL NO.	
TYPE	FORM	INS. CLASS F	RATING CONT.	FRAME 6810USS	S.F.	ENCLOSURE WP-I
TOSHIBA INTERNATIONAL CORPORATION HOUSTON, TEXAS U.S.A.						
3rd ANGLE PROJ.	PREPARED BY: R.CANTU	DATE: 06/16/14	CHECKED BY:	DATE:	DRAWING NO.: MDSL0086-71	REV. 0

TYPICAL MOTOR PERFORMANCE DATA

Model: M703WPQL11F-C

HP	kW	Pole	FL RPM	Frame	Voltage	Hz	Phase	FL Amps
3500	2611	2	3580	6810USS	4000	60	3	431
Enclosure	IP	Ins. Class	S.F.	Duty	NEMA Nom. Eff.	NEMA Design	kVA Code	Ambient (°C)
WP-I	23	F	1.15	CONT	96.2	-		40 C

Load	HP	kW	Amperes	Efficiency (%)	Power Factor (%)
Full Load	3500.00	2610.0	430	96.2	91.0
¾ Load	2625.00	1957.5	324	96.1	90.8
½ Load	1750.00	1305.0	222	95.5	88.5
¼ Load	875.00	652.5	130	93.2	77.5
No Load			72.5		7.8
Locked Rotor			2602		15.2

Torque				Rotor wk ² Inertia (lb-ft ²)
Full Load (lb-ft)	Locked Rotor (% FLT)	Pull Up (% FLT)	Break Down (% FLT)	
5135	75	80	185	551.97

Safe Stall Time(s)		Sound Pressure dB(A) @ 1M	Bearings*		Approx. Motor Weight (lbs)
Cold	Hot		DE	NDE	
9	5	-	M11-125 INS	M11-125 INS	

*Bearings are the only recommended spare part(s).

Motor Options:
Product Family:ODP & WP-I
Mounting:Footed,Shaft:USS Shaft

Customer	
Customer PO	
Sales Order	
Project #	

Tag:

All characteristics are average expected values.

TOSHIBA INTERNATIONAL CORPORATION · HOUSTON, TEXAS U.S.A.

Engineering	bmammen	Doc. Written By	D. Suarez	Doc.# / Rev	MPCF-1119 / 0
Engr. Date	6/18/2014	Doc. Approved By	M. Campbell	Doc. Issued	6/8/2011

SPEED TORQUE/CURRENT CURVE

Model: M703WPQL11F-C

HP	kW	Pole	FL RPM	Frame	Voltage	Hz	Phase	FL Amps
3500	2611	2	3580	6810USS	4000	60	3	431
Enclosure	IP	Ins. Class	S.F.	Duty	NEMA Nom. Eff.	NEMA Design	kVA Code	Ambient (°C)
WP-I	23	F	1.15	CONT	96.2	-		40 C
Locked Rotor Amps	Rotor wk ² Inertia (lb-ft ²)	Torque						Break Down (%)
		Full Load (lb-ft)	Locked Rotor (%)	Pull Up (%)				
2602	551.97	5135	75	80			185	

Design Values

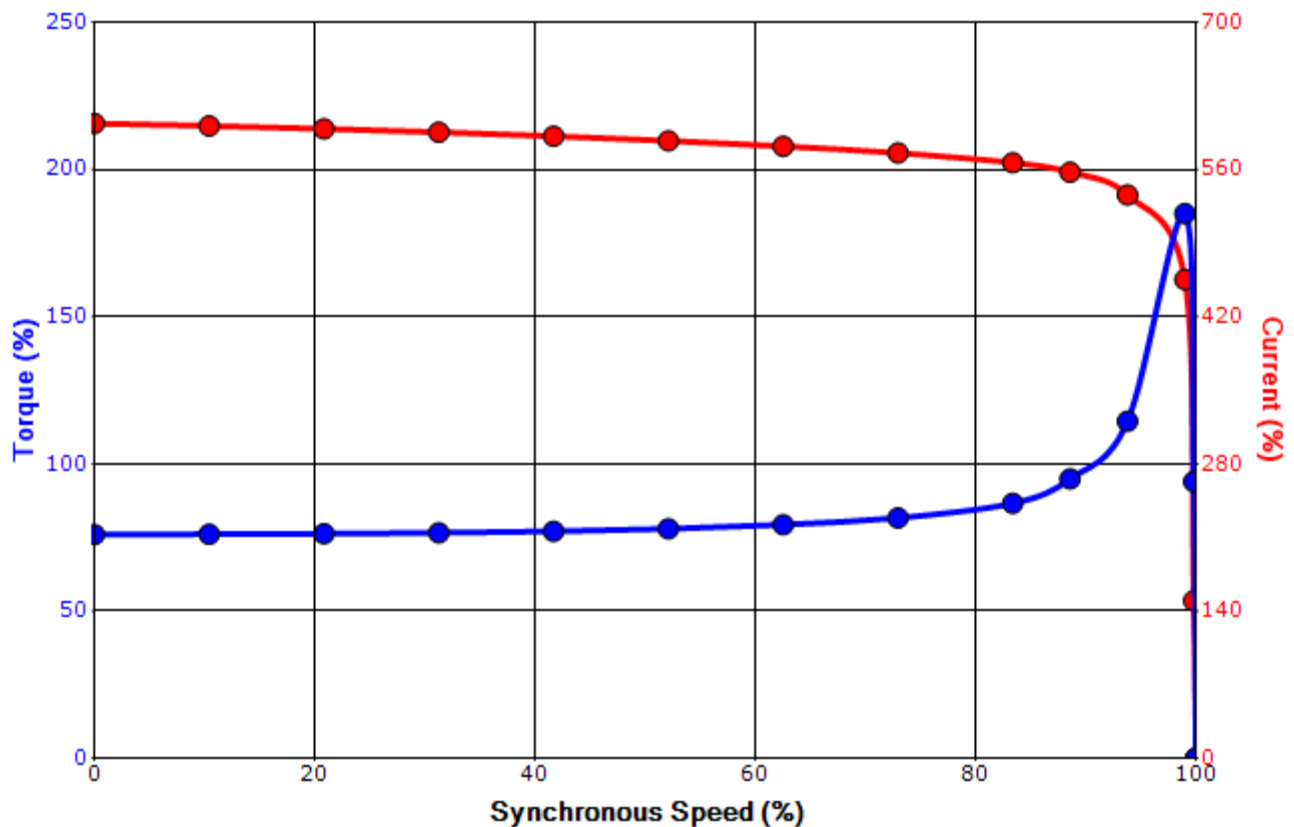

Customer		wk ² Load Inertia (lb-ft ²)	-
Customer PO		Load Type	-
Sales Order		Voltage (%)	100
Project #		Accel. Time	-

Tag:

All characteristics are average expected values.