

4 X Ø14.5 thru  
EQS-BC Ø215

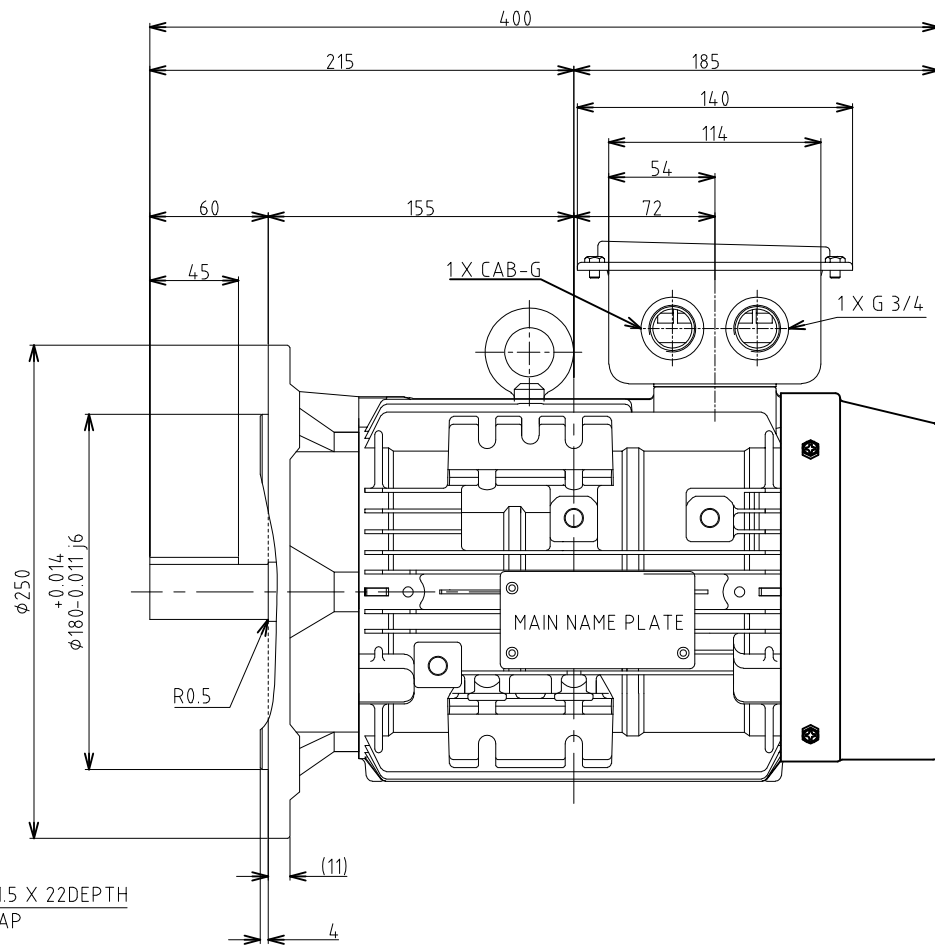
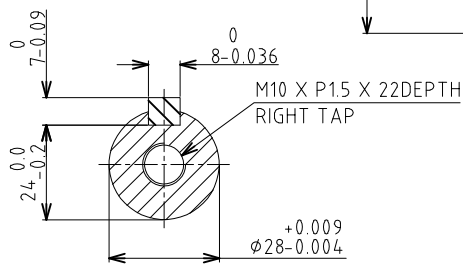

← ODE

ROTATION: CCW  
VIEW FROM: ODE

UNIT: mm

TOSHIBA RESERVES THE RIGHT TO MAKE CHANGES OF TECHNICAL IMPROVEMENT WITHOUT NOTICE. DO NOT USE FOR CONSTRUCTION, INSTALLATION, OR APPLICATION PURPOSES UNLESS THE DRAWING IS CERTIFIED.

B5-FLANGE MOTOR  
OL DRAWING IEC GLOBAL

TYPE: 6P - 400V  
FRAME: 100L

TOLERANCES  
X. ±2.0  
X.X ±0.5  
X.XX ±0.1

3HFN000325

MAXIMUM  
MOTOR WEIGHT  
- lbs.  
- kgs.



DRAWN BY: HIEN. NGUYEN  
CHECK BY: B.X.QUYNH  
APPROVED BY: JAY BUGBEE  
www.toshiba.com/ind

TOSHIBA  
TOSHIBA INTERNATIONAL CORPORATION

01	Remove tolerance T dimension	T.Danh	Sep-10-18	B.Quynh
NO	REVISION	DRAWN BY	DATE	CHECK

**TOSHIBA INTERNATIONAL CORPORATION**  
**Industrial Division / Houston Motor Plant**

**SQUIRREL CAGE INDUCTION MOTOR**  
**PERFORMANCE SPECIFICATIONS**

INDEX	MPCF-1033
SHEET NO.	1 of 1
ISSUED	7/31/13
SUPERSEDES	11/8/96
REVISION	2
WRITTEN BY	MDC
APPROVED BY	PAA

CUSTOMER: -  
TIC SR No.: -

**MOTOR NAMEPLATE DATA**

H.P.: -	VOLTS: 230/400	3 PH / 50 Hz	S. RPM: 1000
FRAME: 100L	ENCL: TEFC	FLAMPS: 6.6/3.8	FLRPM: 970
FORM: FBKL1	S.F.: -	IEC DESIGN N	INSUL CLASS: F
TYPE: IKH	AMB.: 40°C	CODE: -	DUTY: Cont.
MODEL No.: Y156SDMV7JS-PL		kW: 1.5	
NOM. EFF.: 82.5	MIN. EFF.: -	cosØ 0.66	

**AMPERAGE**

LOCKED ROTOR: 48/28

**TORQUES**

FULL LOAD (lb-ft.): 10.8  
LOCKED ROTOR (%): 325  
BREAK DOWN (%): 485

**\*\*BEARINGS:**

DRIVE END: REFER TO NP  
OPPOSITE DRIVE END: REFER TO NP

**EFFICIENCY**

FULL LOAD: 86.7  
3/4 LOAD: 85.7  
1/2 LOAD: 82.2

**POWER FACTOR**

FULL LOAD: 66.1  
3/4 LOAD: 58.3  
1/2 LOAD: 46.1

ALL CHARACTERISTICS ARE AVERAGE EXPECTED VALUES BASED UPON RATED VOLTAGE,  
FREQUENCY AND SINEWAVE POWER INPUT.

THE DECLARED LOCKED ROTOR CURRENT HAS A TOLERANCE OF 20%.

\* TEMPERATURE RISE WILL BE CONSISTENT WITH INSULATION, AMBIENT AND SERVICE FACTOR AS  
DEFINED BY NEMA-MG-12 OR -20.

\*\* BEARINGS ARE THE ONLY RECOMMENDED SPARE PART(S).

**CERTIFIED BY:** Zichao Xie

**DATE:** 6/25/2020

# TOSHIBA INTERNATIONAL CORPORATION

## Speed Torque/Current Curve

<b>Model #:</b>	Y156SDMV7JS-PL			<b>FLAmps:</b>	6.6/3.8
<b>Enclosure:</b>	TEFC	<b>Voltage:</b>	230/400 V	<b>Frame:</b>	100L
<b>Pole:</b>	6	<b>Frequency:</b>	3 PH / 50 Hz	<b>Ins. Class:</b>	F
<b>KW:</b>	1.5	<b>Rotor Inertia:</b>	0.39 lb-ft <sup>2</sup>	<b>Date:</b>	6/25/2020
<b>FLRPM:</b>	970	<b>Load Inertia:</b>	N/A	<b>File:</b>	GH6Y15 (1.5kW)

<b>Locked Rotor Amps:</b>	48/28 A	<b>Load Type:</b>	N/A
<b>Locked Rotor Torque:</b>	325%	<b>Starting at:</b>	N/A
<b>Breakdown Torque:</b>	485%	<b>Accel. Time:</b>	N/A
<b>Rated Torque:</b>	10.8 lb-ft		

### *Design Values*

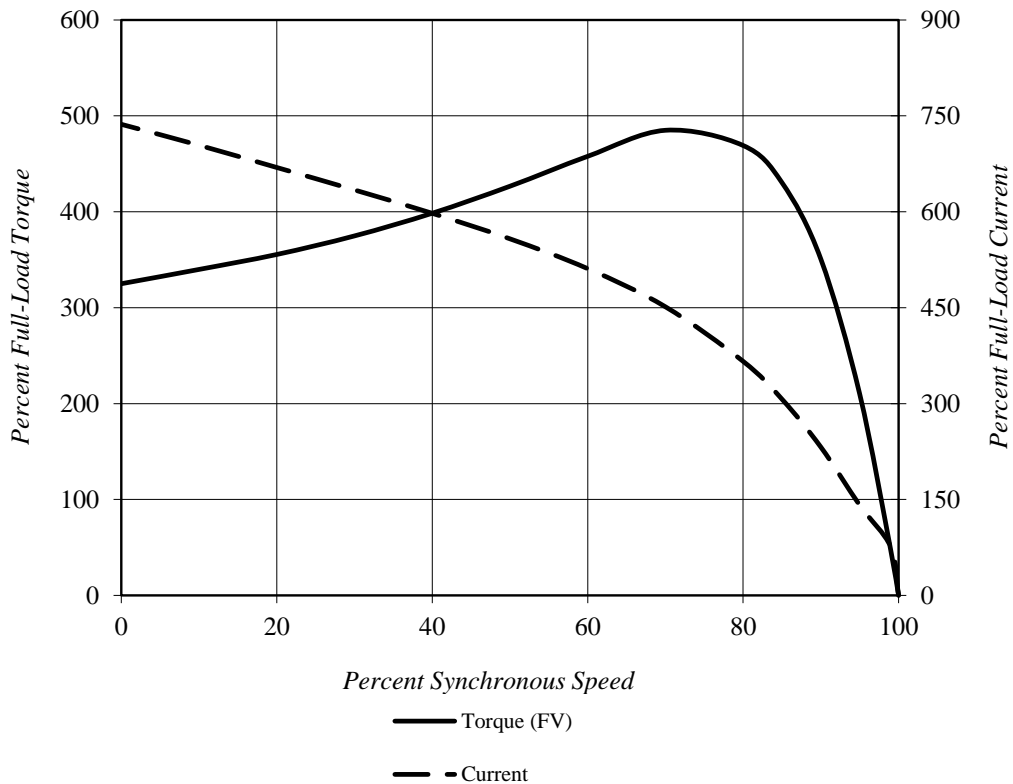

**Comments:** PROJECT -  
 \_\_\_\_\_  
 \_\_\_\_\_  
 \_\_\_\_\_

**D.E.Curve #:** GH6Y15 (1.5kW)

**Prepared by:** Zichao Xie

**Checked by:**

# TOSHIBA INTERNATIONAL CORPORATION

## Thermal Limit & Acceleration Curves

*Design Values (For Reference Only)*

<b>Model #:</b>	Y156SDMV7JS-PL			<b>FLAmps:</b>	6.6/3.8
<b>Enclosure:</b>	TEFC	<b>Voltage:</b>	230/400 V	<b>Frame:</b>	100L
<b>Pole:</b>	6	<b>Frequency:</b>	3 PH / 50 Hz	<b>Ins. Class:</b>	F
<b>KW:</b>	1.5	<b>Rotor Inertia:</b>	0.39 lb-ft <sup>2</sup>	<b>Date:</b>	6/25/2020
<b>FLRPM:</b>	970	<b>Load Inertia:</b>	N/A	<b>File:</b>	GH6Y15 (1.5kW)

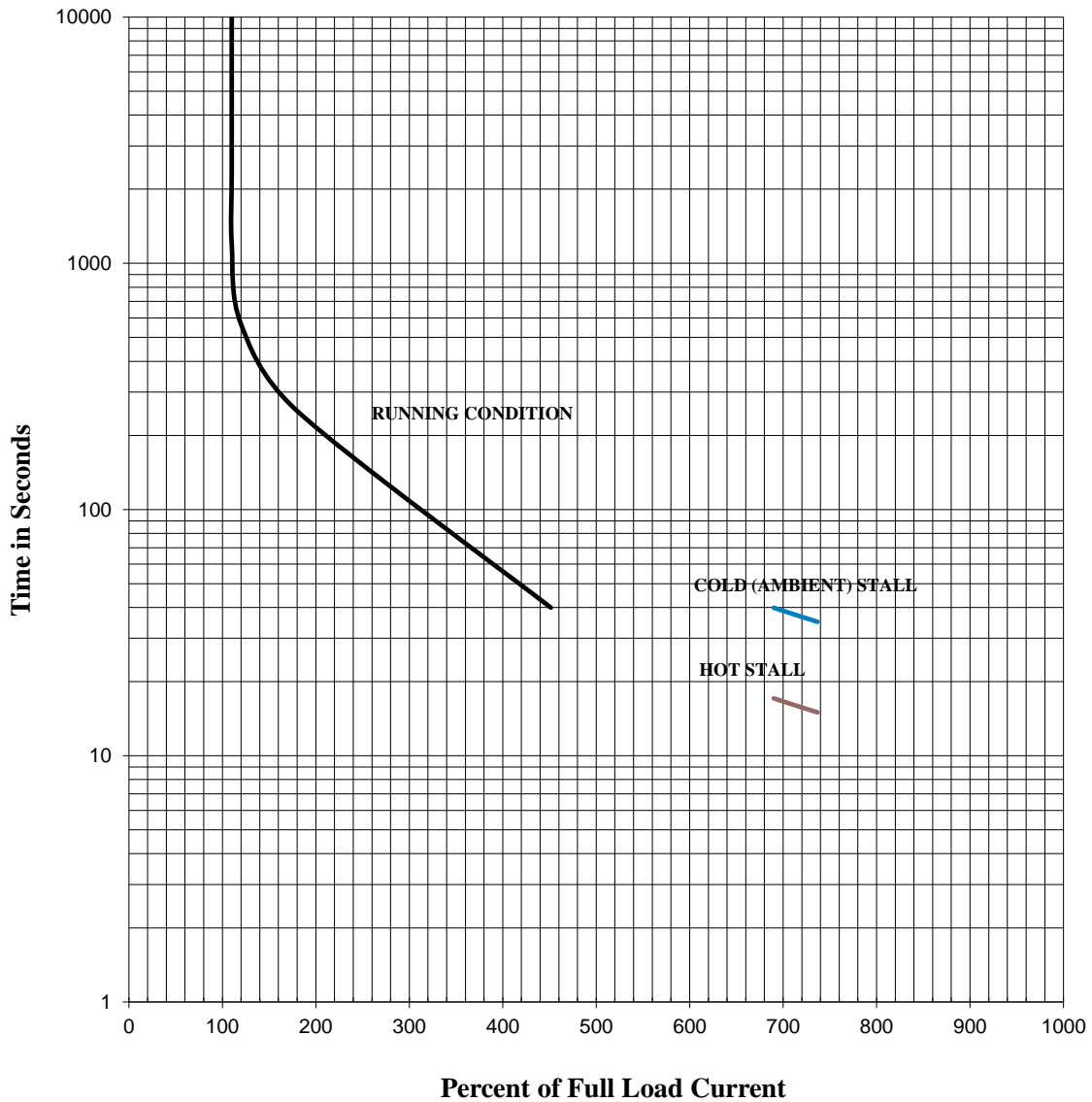

**Comments:** PROJECT -  
 \_\_\_\_\_  
 \_\_\_\_\_  
 \_\_\_\_\_

**D.E.Curve #:** GH6Y15 (1.5kW)

**Prepared by:** Zichao Xie

**Checked by:**

**TOSHIBA INTERNATIONAL CORPORATION**  
**Industrial Division / Houston Motor Plant**

**SQUIRREL CAGE INDUCTION MOTOR**  
**PERFORMANCE SPECIFICATIONS**

INDEX	MPCF-1033
SHEET NO.	1 of 1
ISSUED	7/31/13
SUPERSEDES	11/8/96
REVISION	2
WRITTEN BY	MDC
APPROVED BY	PAA

CUSTOMER: -  
TIC SR No.: -

**MOTOR NAMEPLATE DATA**

H.P.: -	VOLTS: 240/415	3 PH / 50 Hz	S. RPM: 1000
FRAME: 100L	ENCL: TEFC	FLAMPS: 6.6/3.8	FLRPM: 970
FORM: FBKL1	S.F.: -	IEC DESIGN N	INSUL CLASS: F
TYPE: IKH	AMB.: 40°C	CODE: -	DUTY: Cont.
MODEL No.: Y156SDMV7JS-PL		kW: 1.5	
NOM. EFF.: 82.5	MIN. EFF.: -	cosØ 0.63	

**AMPERAGE**

LOCKED ROTOR: 50/29

**TORQUES**

FULL LOAD (lb-ft.): 10.8  
 LOCKED ROTOR (%): 355  
 BREAK DOWN (%): 520

**\*\*BEARINGS:**

DRIVE END: REFER TO NP  
 OPPOSITE DRIVE END: REFER TO NP

**EFFICIENCY**

FULL LOAD: 86.8  
 3/4 LOAD: 85.5  
 1/2 LOAD: 82.5

**POWER FACTOR**

FULL LOAD: 63.6  
 3/4 LOAD: 55.3  
 1/2 LOAD: 47.0

ALL CHARACTERISTICS ARE AVERAGE EXPECTED VALUES BASED UPON RATED VOLTAGE,  
 FREQUENCY AND SINEWAVE POWER INPUT.

THE DECLARED LOCKED ROTOR CURRENT HAS A TOLERANCE OF 20%.

\* TEMPERATURE RISE WILL BE CONSISTENT WITH INSULATION, AMBIENT AND SERVICE FACTOR AS  
 DEFINED BY NEMA-MG-12 OR -20.

\*\* BEARINGS ARE THE ONLY RECOMMENDED SPARE PART(S).

**CERTIFIED BY:** Zichao Xie

**DATE:** 6/25/2020

# TOSHIBA INTERNATIONAL CORPORATION

## Speed Torque/Current Curve

<b>Model #:</b>	Y156SDMV7JS-PL			<b>FLAmps:</b>	6.6/3.8
<b>Enclosure:</b>	TEFC	<b>Voltage:</b>	240/415 V	<b>Frame:</b>	100L
<b>Pole:</b>	6	<b>Frequency:</b>	3 PH / 50 Hz	<b>Ins. Class:</b>	F
<b>KW:</b>	1.5	<b>Rotor Inertia:</b>	0.39 lb-ft <sup>2</sup>	<b>Date:</b>	6/25/2020
<b>FLRPM:</b>	970	<b>Load Inertia:</b>	N/A	<b>File:</b>	GH6Y15 (1.5kW)

<b>Locked Rotor Amps:</b>	50/29 A	<b>Load Type:</b>	N/A
<b>Locked Rotor Torque:</b>	355%	<b>Starting at:</b>	N/A
<b>Breakdown Torque:</b>	520%	<b>Accel. Time:</b>	N/A
<b>Rated Torque:</b>	10.8 lb-ft		

### *Design Values*

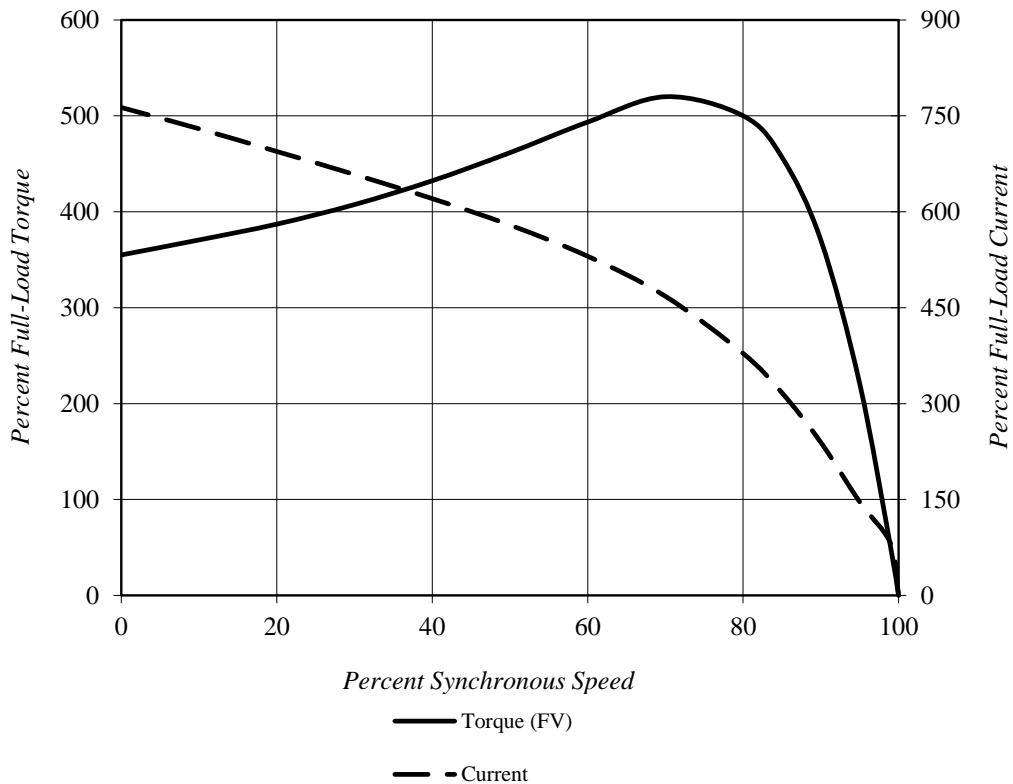

**Comments:** PROJECT -  
 \_\_\_\_\_  
 \_\_\_\_\_  
 \_\_\_\_\_

**D.E. Curve #:** GH6Y15 (1.5kW)

**Prepared by:** Zichao Xie

**Checked by:**

# TOSHIBA INTERNATIONAL CORPORATION

## Thermal Limit & Acceleration Curves

*Design Values (For Reference Only)*

<b>Model #:</b>	Y156SDMV7JS-PL			<b>FLAmps:</b>	6.6/3.8
<b>Enclosure:</b>	TEFC	<b>Voltage:</b>	240/415 V	<b>Frame:</b>	100L
<b>Pole:</b>	6	<b>Frequency:</b>	3 PH / 50 Hz	<b>Ins. Class:</b>	F
<b>KW:</b>	1.5	<b>Rotor Inertia:</b>	0.39 lb-ft <sup>2</sup>	<b>Date:</b>	6/25/2020
<b>FLRPM:</b>	970	<b>Load Inertia:</b>	N/A	<b>File:</b>	GH6Y15 (1.5kW)

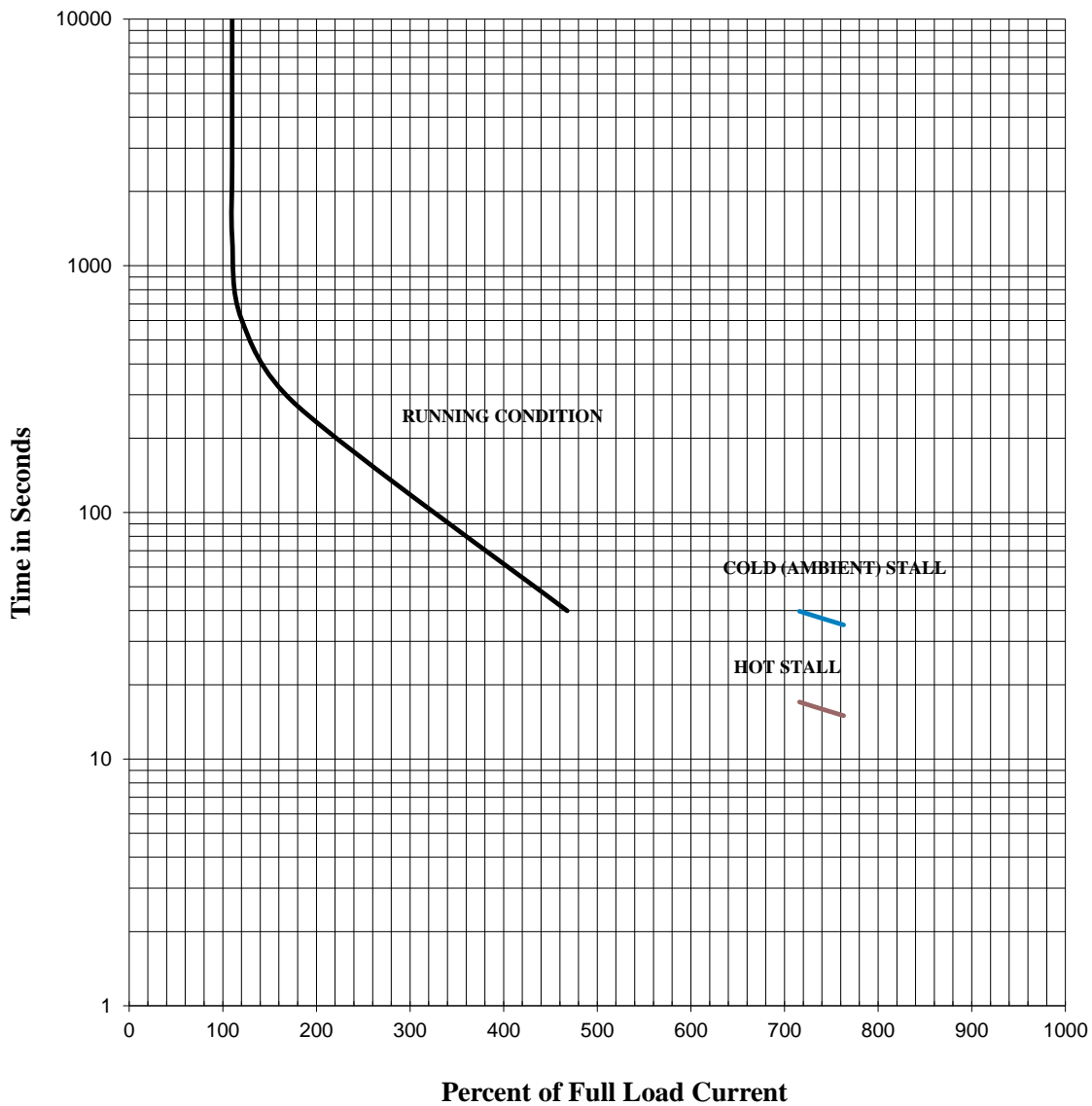

**Comments:** PROJECT -  
 \_\_\_\_\_  
 \_\_\_\_\_  
 \_\_\_\_\_

**D.E.Curve #:** GH6Y15 (1.5kW)

**Prepared by:** Zichao Xie

**Checked by:**

**TOSHIBA INTERNATIONAL CORPORATION**  
**Industrial Division / Houston Motor Plant**

**SQUIRREL CAGE INDUCTION MOTOR**  
**PERFORMANCE SPECIFICATIONS**

INDEX	MPCF-1033
SHEET NO.	1 of 1
ISSUED	7/31/13
SUPERSEDES	11/8/96
REVISION	2
WRITTEN BY	MDC
APPROVED BY	PAA

CUSTOMER: -  
TIC SR No.: -

**MOTOR NAMEPLATE DATA**

H.P.: -	VOLTS: 220/380	3 PH / 50 Hz	S. RPM: 1000
FRAME: 100L	ENCL: TEFC	FLAMPS: 6.6/3.8	FLRPM: 965
FORM: FBKL1	S.F.: -	IEC DESIGN N	INSUL CLASS: F
TYPE: IKH	AMB.: 40°C	CODE: -	DUTY: Cont.
MODEL No.: Y156SDMV7JS-PL		kW: 1.5	
NOM. EFF.: 82.5	MIN. EFF.: -	cosØ 0.69	

**AMPERAGE**

LOCKED ROTOR: 45/26

**TORQUES**

FULL LOAD (lb-ft.): 10.9  
LOCKED ROTOR (%): 280  
BREAK DOWN (%): 445

**\*\*BEARINGS:**

DRIVE END: REFER TO NP  
OPPOSITE DRIVE END: REFER TO NP

**EFFICIENCY**

FULL LOAD: 86.5  
3/4 LOAD: 86.0  
1/2 LOAD: 83.1

**POWER FACTOR**

FULL LOAD: 69.0  
3/4 LOAD: 61.8  
1/2 LOAD: 49.9

ALL CHARACTERISTICS ARE AVERAGE EXPECTED VALUES BASED UPON RATED VOLTAGE,  
FREQUENCY AND SINEWAVE POWER INPUT.

THE DECLARED LOCKED ROTOR CURRENT HAS A TOLERANCE OF 20%.

\* TEMPERATURE RISE WILL BE CONSISTENT WITH INSULATION, AMBIENT AND SERVICE FACTOR AS  
DEFINED BY NEMA-MG-12 OR -20.

\*\* BEARINGS ARE THE ONLY RECOMMENDED SPARE PART(S).

**CERTIFIED BY:** Zichao Xie

**DATE:** 6/25/2020



# TOSHIBA INTERNATIONAL CORPORATION

## Speed Torque/Current Curve

<b>Model #:</b>	Y156SDMV7JS-PL			<b>FLAmps:</b>	6.6/3.8
<b>Enclosure:</b>	TEFC	<b>Voltage:</b>	220/380 V	<b>Frame:</b>	100L
<b>Pole:</b>	6	<b>Frequency:</b>	3 PH / 50 Hz	<b>Ins. Class:</b>	F
<b>KW:</b>	1.5	<b>Rotor Inertia:</b>	0.39 lb-ft <sup>2</sup>	<b>Date:</b>	6/25/2020
<b>FLRPM:</b>	965	<b>Load Inertia:</b>	N/A	<b>File:</b>	GH6Y15 (1.5kW)

<b>Locked Rotor Amps:</b>	45/26 A	<b>Load Type:</b>	N/A
<b>Locked Rotor Torque:</b>	280%	<b>Starting at:</b>	N/A
<b>Breakdown Torque:</b>	445%	<b>Accel. Time:</b>	N/A
<b>Rated Torque:</b>	10.9 lb-ft		

### Design Values

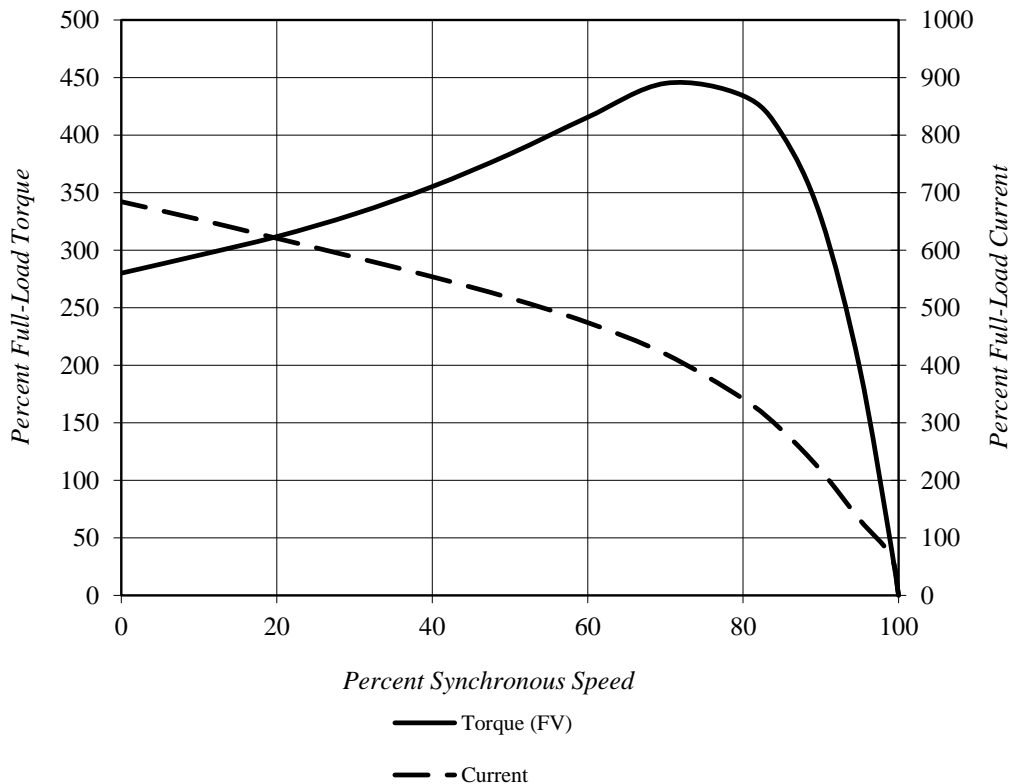

**Comments:** PROJECT -  
 \_\_\_\_\_  
 \_\_\_\_\_  
 \_\_\_\_\_

**D.E.Curve #:** GH6Y15 (1.5kW)

**Prepared by:** Zichao Xie

**Checked by:**

# TOSHIBA INTERNATIONAL CORPORATION

## Thermal Limit & Acceleration Curves

*Design Values (For Reference Only)*

<b>Model #:</b>	Y156SDMV7JS-PL			<b>FLAmps:</b>	6.6/3.8
<b>Enclosure:</b>	TEFC	<b>Voltage:</b>	220/380 V	<b>Frame:</b>	100L
<b>Pole:</b>	6	<b>Frequency:</b>	3 PH / 50 Hz	<b>Ins. Class:</b>	F
<b>KW:</b>	1.5	<b>Rotor Inertia:</b>	0.39 lb-ft <sup>2</sup>	<b>Date:</b>	6/25/2020
<b>FLRPM:</b>	965	<b>Load Inertia:</b>	N/A	<b>File:</b>	GH6Y15 (1.5kW)

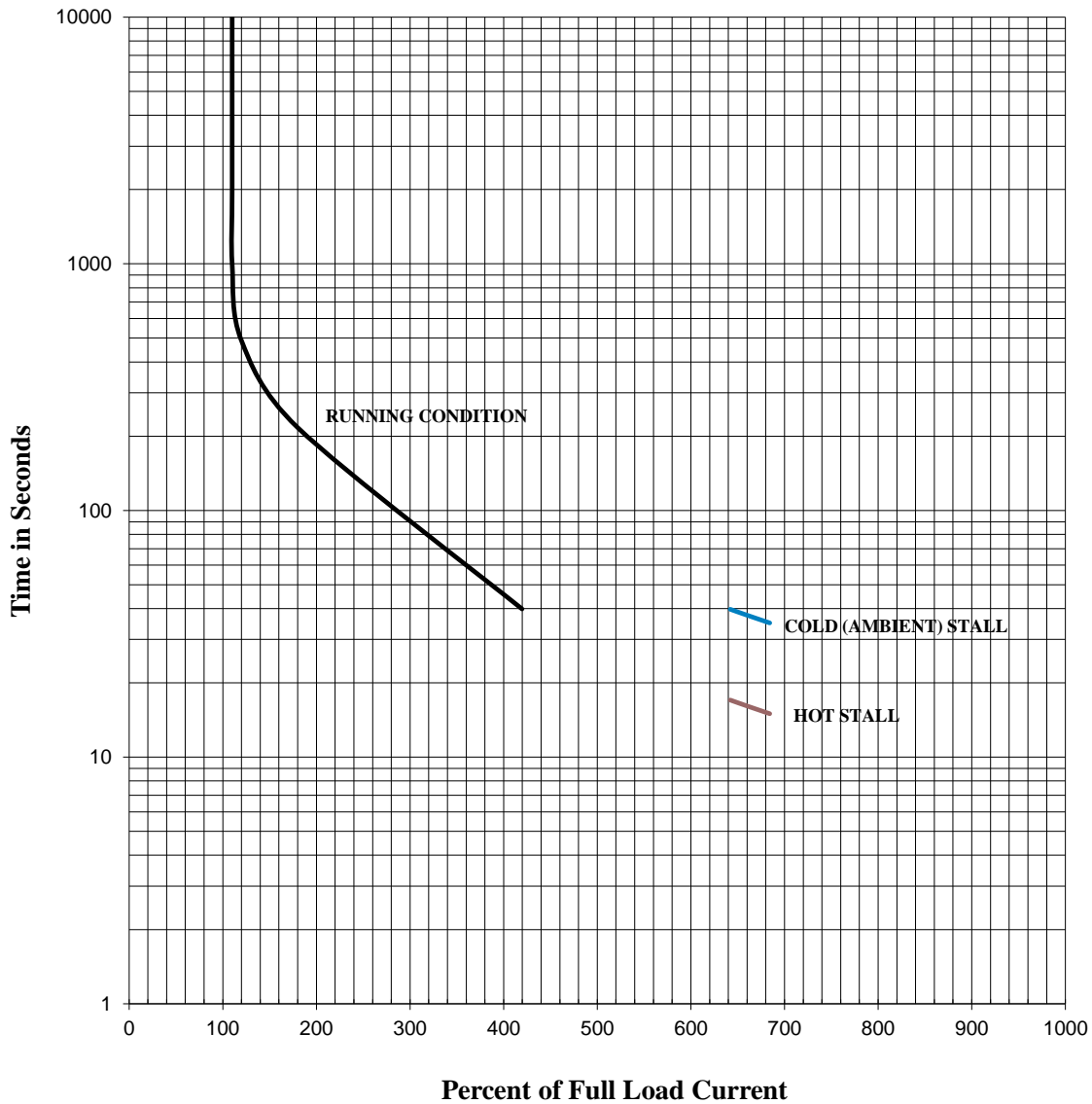

**Comments:** PROJECT -  
 \_\_\_\_\_  
 \_\_\_\_\_  
 \_\_\_\_\_

**D.E.Curve #:** GH6Y15 (1.5kW)

**Prepared by:** Zichao Xie

**Checked by:**

**TOSHIBA INTERNATIONAL CORPORATION**  
**Industrial Division / Houston Motor Plant**

**SQUIRREL CAGE INDUCTION MOTOR**  
**PERFORMANCE SPECIFICATIONS**

INDEX	MPCF-1033
SHEET NO.	1 of 1
ISSUED	7/31/13
SUPERSEDES	11/8/96
REVISION	2
WRITTEN BY	MDC
APPROVED BY	PAA

CUSTOMER: -  
TIC SR No.: -

**MOTOR NAMEPLATE DATA**

H.P.: 2	VOLTS: 460	3 PH / 60 Hz	S. RPM: 1200
FRAME: 100L	ENCL: TEFC	FLAMPS: 3.4	FLRPM: 1175
FORM: FBKL1	S.F.: 1.15	NEMA DESIGN: A	INSUL CLASS: F
TYPE: IKH	AMB.: 40°C	CODE: M	DUTY: Cont.
MODEL No.: Y156SDMV7JS-PL		kW: 1.5	
NOM. EFF.: 88.5	MIN. EFF.: -	P.F.: 62.0	

**AMPERAGE**

LOCKED ROTOR: 27

**TORQUES**

FULL LOAD (lb-ft.): 8.9  
LOCKED ROTOR (%): 375  
BREAK DOWN (%): 520

**\*\*BEARINGS:**

DRIVE END: REFER TO NP  
OPPOSITE DRIVE END: REFER TO NP

**EFFICIENCY**

FULL LOAD: 87.8  
3/4 LOAD: 86.2  
1/2 LOAD: 82.1

**POWER FACTOR**

FULL LOAD: 62.4  
3/4 LOAD: 54.4  
1/2 LOAD: 42.6

ALL CHARACTERISTICS ARE AVERAGE EXPECTED VALUES BASED UPON RATED VOLTAGE,  
FREQUENCY AND SINEWAVE POWER INPUT.

THE DECLARED LOCKED ROTOR CURRENT HAS A TOLERANCE OF 20%.

\* TEMPERATURE RISE WILL BE CONSISTENT WITH INSULATION, AMBIENT AND SERVICE FACTOR AS  
DEFINED BY NEMA-MG-12 OR -20.

\*\* BEARINGS ARE THE ONLY RECOMMENDED SPARE PART(S).

**CERTIFIED BY:** Zichao Xie

**DATE:** 6/9/2020

# TOSHIBA INTERNATIONAL CORPORATION

## Speed Torque/Current Curve

<b>Model #:</b>	Y156SDMV7JS-PL			<b>FLAmps:</b>	3.4
<b>Enclosure:</b>	TEFC	<b>Voltage:</b>	460 V	<b>Frame:</b>	100L
<b>Pole:</b>	6	<b>Frequency:</b>	3 PH / 60 Hz	<b>Ins. Class:</b>	F
<b>HP:</b>	2	<b>Rotor Inertia:</b>	0.39 lb-ft <sup>2</sup>	<b>Date:</b>	6/9/2020
<b>FLRPM:</b>	1175	<b>Load Inertia:</b>	N/A	<b>File:</b>	GH6Y15 (1.5kW)

<b>Locked Rotor Amps:</b>	27 A	<b>Load Type:</b>	N/A
<b>Locked Rotor Torque:</b>	375%	<b>Starting at:</b>	N/A
<b>Breakdown Torque:</b>	520%	<b>Accel. Time:</b>	N/A
<b>Rated Torque:</b>	8.9 lb-ft		

### *Design Values*

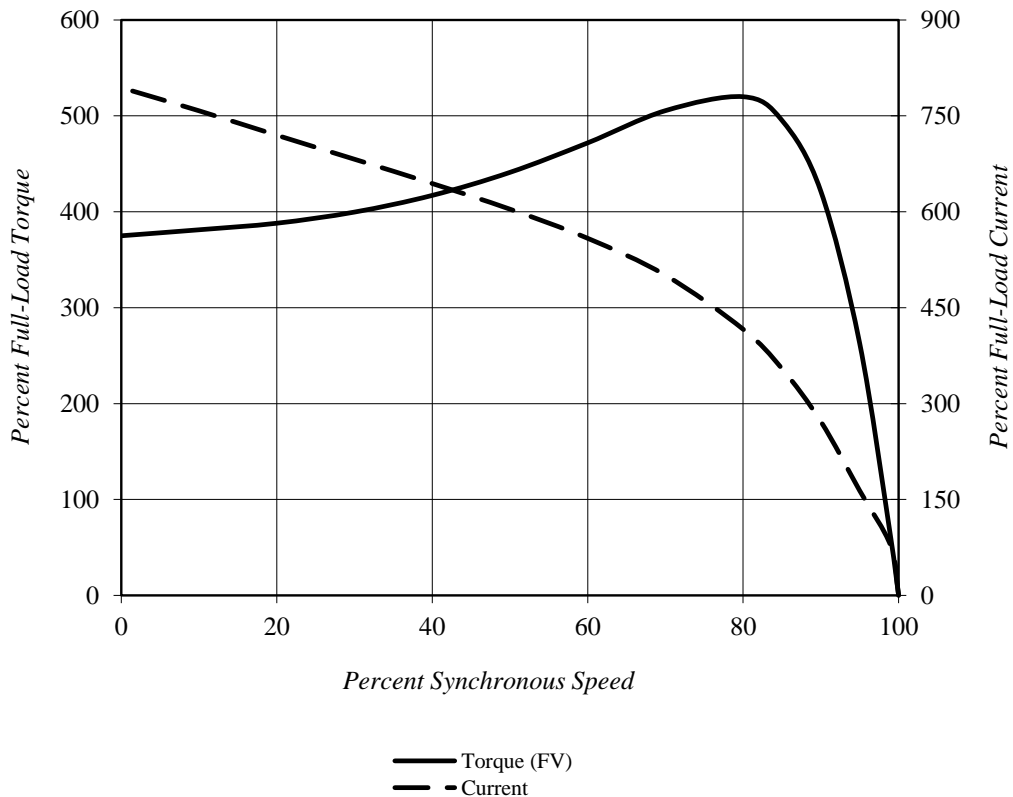

**Comments:** PROJECT -  
 \_\_\_\_\_  
 \_\_\_\_\_  
 \_\_\_\_\_

**D.E.Curve #:** GH6Y15 (1.5kW)

**Prepared by:** Zichao Xie

**Checked by:**

# TOSHIBA INTERNATIONAL CORPORATION

## Thermal Limit & Acceleration Curves

*Design Values (For Reference Only)*

<b>Model #:</b>	Y156SDMV7JS-PL			<b>FLAmps:</b>	3.4
<b>Enclosure:</b>	TEFC	<b>Voltage:</b>	460 V	<b>Frame:</b>	100L
<b>Pole:</b>	6	<b>Frequency:</b>	3 PH / 60 Hz	<b>Ins. Class:</b>	F
<b>HP:</b>	2	<b>Rotor Inertia:</b>	0.39 lb-ft <sup>2</sup>	<b>Date:</b>	6/9/2020
<b>FLRPM:</b>	1175	<b>Load Inertia:</b>	N/A	<b>File:</b>	GH6Y15 (1.5kW)

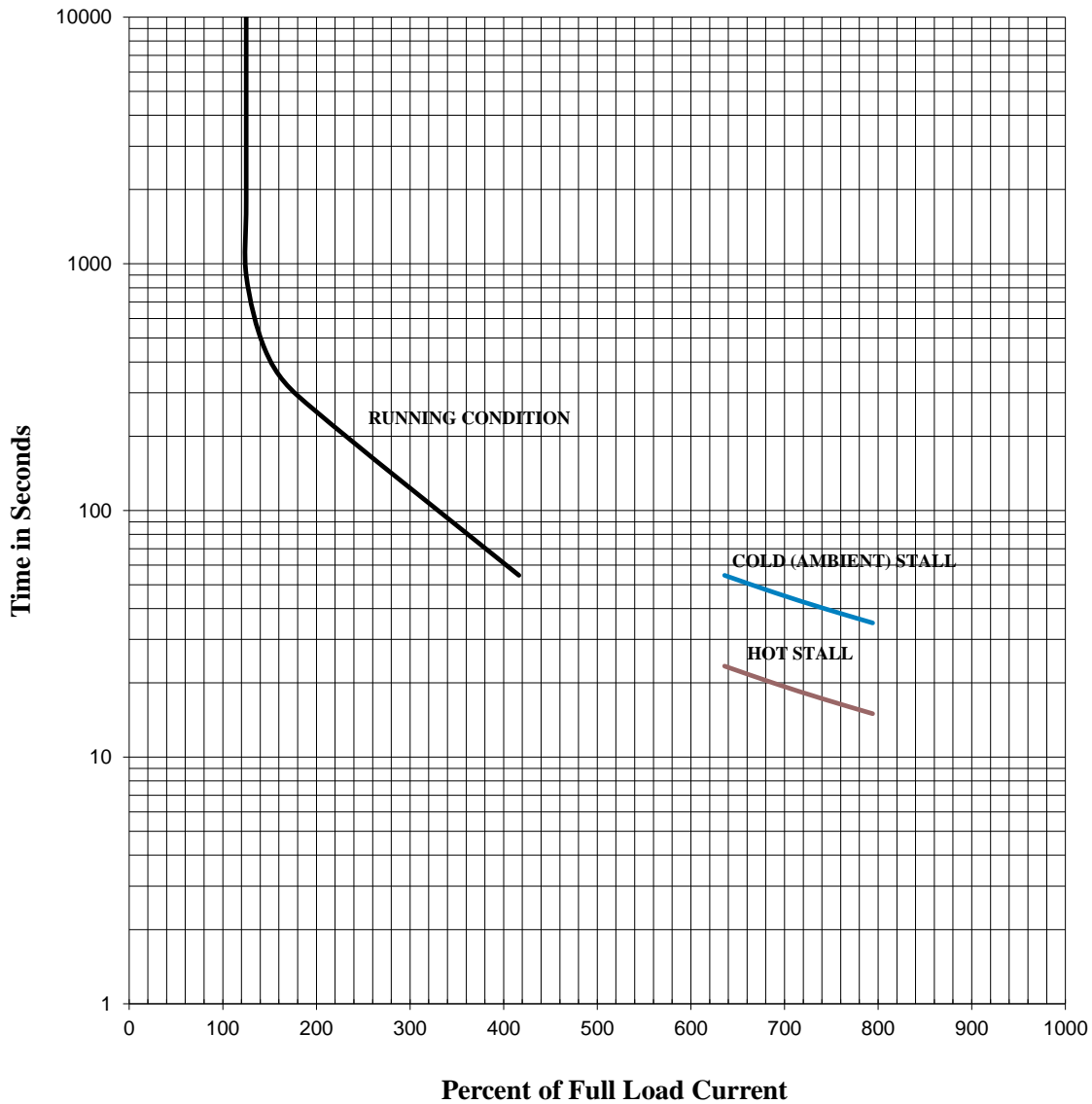

**Comments:** PROJECT -  
 \_\_\_\_\_  
 \_\_\_\_\_  
 \_\_\_\_\_

**D.E. Curve #:** GH6Y15 (1.5kW)

**Prepared by:** Zichao Xie

**Checked by:**