

NOTE:  
LIFTING EYEBOLTS  
(2) 180° APART  
FOR MOTOR  
LIFTING ONLY

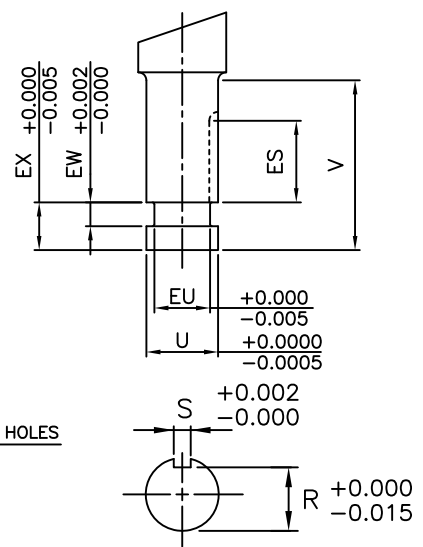
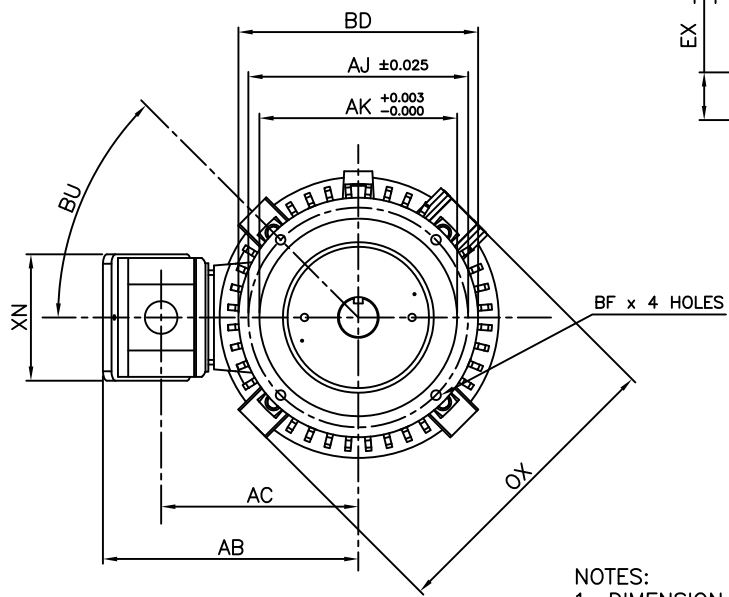

UNITS: INCHES

FRAME SIZE	MOTOR DIMENSIONS					P-FLANGE DIMENSIONS							CONDUIT BOX DIMENSIONS					
	AG	C	P	OX	BU	BB	BE	BF	BD	BV	AK	AJ	AA[NPT]	AB	AC	AF	XL	XN
210HP10/LP10	26.9	29.7	11.8	12.6	45°	0.25	0.91	0.44	10.0	9.3	8.25	9.125	1.00	10.7	8.3	4.0	7.4	5.3

FRAME SIZE	SHAFT EXTENSION DIMENSIONS										BEARINGS		MAXIMUM WEIGHT
	AH	EU	U	V	R	S	ES	EW	EX	LS	OS		
210HP10	2.75	0.875	1.125	2.75	0.986	0.25	1.28	0.375	0.75	6309C3	6308C3	250 lbs.	
210LP10	2.75	1.250	1.625	2.75	1.416	0.38	1.28	0.375	0.75	6309C3	7308BEGAM x 2		

- NOTES:
1. DIMENSION V REPRESENTS LENGTH OF STRAIGHT PART OF SHAFT
  2. MAIN CONDUIT BOX MAY BE ROTATED IN 90° INCREMENTS
  3. KEY DIMENSIONS EQUAL S x S x ES (MOTOR SUPPLIED WITH KEY)
  4. MOTOR WEIGHT SHOWN IS MAXIMUM HORSEPOWER IN FRAME
  5. STANDARD PRODUCT USE BI-DIRECTIONAL FAN. OPPOSITE ROTATION AVAILABLE ONLY BY CONNECTION CHANGE

CUSTOMER: \_\_\_\_\_ MOTOR MODEL NO.: \_\_\_\_\_  
 P.O. NO.: \_\_\_\_\_ HP: \_\_\_\_\_ VOLTAGE: \_\_\_\_\_ RPM(SYN.): \_\_\_\_\_ Hz: \_\_\_\_\_  
 FRAME SIZE: \_\_\_\_\_ PRODUCT TYPE: VERTICAL SOLID SHAFT ROUND BODY P-FLANGE  
 COMMENTS: \_\_\_\_\_  
 \_\_\_\_\_  
 PER: \_\_\_\_\_ DATE: \_\_\_\_\_

TAG NO's.:  
 .  
 .  
 .  
 .  
 .  
 .  
 .  
 .

STANDARD (NO AUX. BOXES)  
 RTD AUX. BOX  
 SPACE HEATER AUX. BOX  
 BEARING RTD's

TOSHIBA RESERVES THE RIGHT TO MAKE CHANGES OF TECHNICAL IMPROVEMENT AND THE DATA MAY CHANGE WITHOUT NOTICE  PRELIMINARY  
 DO NOT USE FOR CONSTRUCTION, INSTALLATION, OR APPLICATION PURPOSES UNLESS THE DRAWING IS MARKED AS CERTIFIED  CERTIFIED

**TOSHIBA**  
 TOSHIBA INTERNATIONAL CORPORATION

TOTALLY-ENCLOSED FAN-COOLED  
 VERTICAL SOLID SHAFT ROUND BODY P-FLANGE  
 3 PHASE INDUCTION MOTOR  
 F1 ASSEMBLY

**XT SERIES**  
 VISIT OUR WEBSITE AT:  
 www.toshiba.com/ind



Issued Date	9/24/2019	Transmit #	
Issued By	dschoeck	Issued Rev	

### TYPICAL MOTOR PERFORMANCE DATA

Model: Y752FTVB3PX-A

HP	kW	Pole	FL RPM	Frame	Voltage	Hz	Phase	FL Amps
7.50	5.5	2	3515	210LP10	460	60	3	8.7
Enclosure	IP	Ins. Class	S.F.	Duty	NEMA Nom. Eff.	NEMA Design	kVA Code	Ambient (°C)
TEFC	54	F	1.15	CONT	90.2	B	H	40 C

Load	HP	kW	Amperes	Efficiency (%)	Power Factor (%)
Full Load	7.50	5.6	8.7	90.5	88.5
¾ Load	5.62	4.2	6.8	90.3	85.8
½ Load	3.75	2.8	5.1	89.0	79.0
¼ Load	1.87	1.4	3.8	78.9	58.5
No Load			2.5		11.8
Locked Rotor			63		37.5

Torque				Rotor wk <sup>2</sup> Inertia (lb-ft <sup>2</sup> )
Full Load (lb-ft)	Locked Rotor (% FLT)	Pull Up (% FLT)	Break Down (% FLT)	
11.2	210	225	310	0.52

Safe Stall Time(s)		Sound Pressure dB(A) @ 1M	Bearings*		Approx. Motor Weight (lbs)
Cold	Hot		DE	NDE	
24	14	-	6309C3	7308B	200

\*Bearings are the only recommended spare part(s).

**Motor Options:**  
 Product Family:EQPIII Vertical Medium Thrust  
 Mounting:10 P-Base (180-280 Frame),Shaft:LP Solid Shaft Medium Thrust

Customer	
Customer PO	
Sales Order	
Project #	

Tag:

All characteristics are average expected values.

**TOSHIBA INTERNATIONAL CORPORATION · HOUSTON, TEXAS U.S.A.**

Engineering	gminetos	Doc. Written By	D. Suarez	Doc.# / Rev	MPCF-1119 / 1
Engr. Date	7/23/2013	Doc. Approved By	M. Campbell	Doc. Issued	9/20/2019



Issued Date	9/24/2019	Transmit #	
Issued By	dschoeck	Issued Rev	

### SPEED TORQUE/CURRENT CURVE

Model: Y752FTVB3PX-A

HP	kW	Pole	FL RPM	Frame	Voltage	Hz	Phase	FL Amps
7.50	5.5	2	3515	210LP10	460	60	3	8.7
Enclosure	IP	Ins. Class	S.F.	Duty	NEMA Nom. Eff.	NEMA Design	kVA Code	Ambient (°C)
TEFC	54	F	1.15	CONT	90.2	B	H	40 C
Locked Rotor Amps	Rotor wk <sup>2</sup> Inertia (lb-ft <sup>2</sup> )	Torque						
		Full Load (lb-ft)	Locked Rotor (%)	Pull Up (%)	Break Down (%)			
63	0.52	11.2	210	225	310			

### Design Values

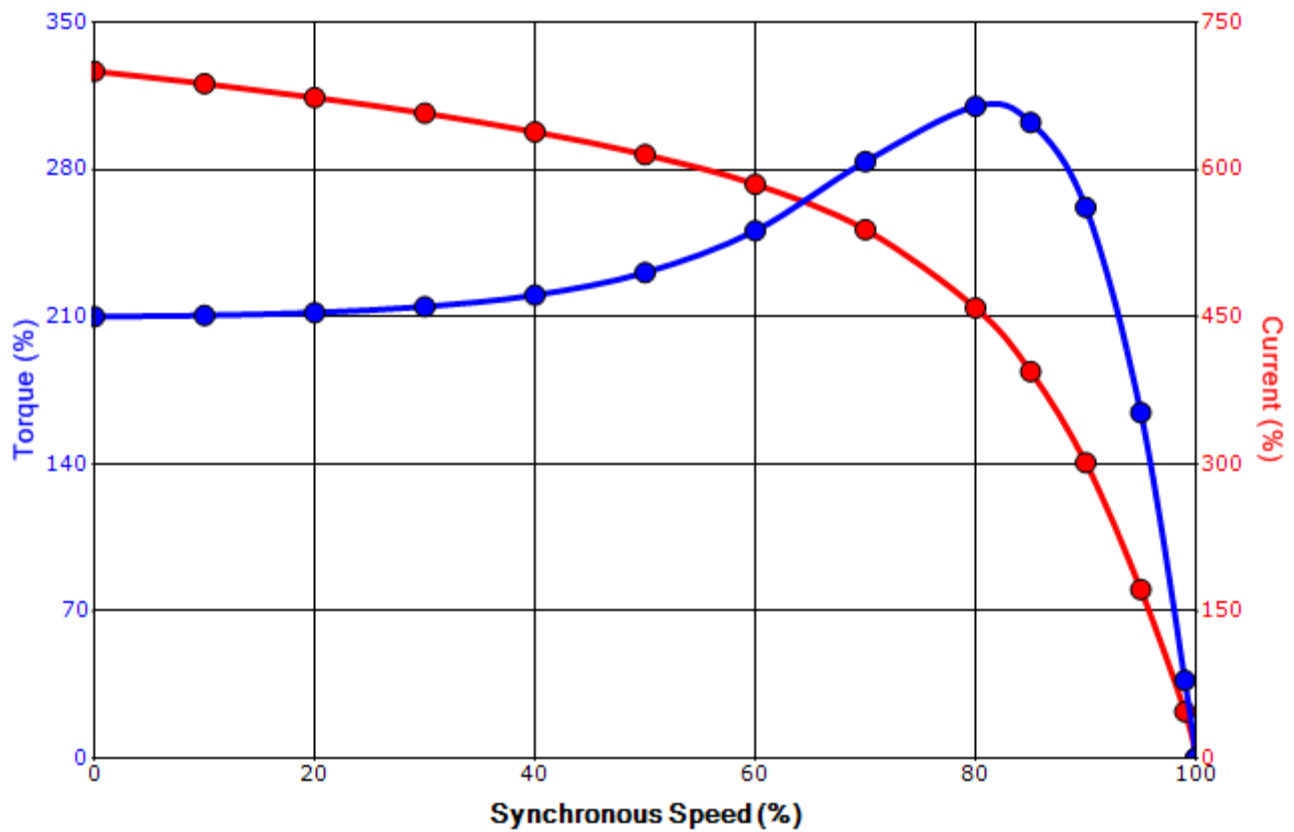

Customer		wk <sup>2</sup> Load Inertia (lb-ft <sup>2</sup> )	-
Customer PO		Load Type	-
Sales Order		Voltage (%)	100
Project #		Accel. Time	-

Tag:

All characteristics are average expected values.

#### TOSHIBA INTERNATIONAL CORPORATION · HOUSTON, TEXAS U.S.A.

Engineering	gminetos	Doc. Written By	D. Suarez	Doc.# / Rev	MPCF-1121/1
Engr. Date	7/23/2013	Doc. Approved By	M. Campbell	Doc. Issued	9/20/2019

### Motor Connection Diagram 3 Leads - Delta Connection



Switch L1 and L2 to reverse rotation

Each lead may consist of more than one cable.  
If multiple cables represent a single lead, each one  
of them will be labeled with the appropriate lead number.