

TOSHIBA

1600XPi SERIES **8-22kVA BATTERY CABINET**

INSTALLATION AND OPERATION MANUAL
SINGLE PHASE – 8/10/14/18/22 kVA: 288Vdc

Part# 64024-006
November 2019

IMPORTANT NOTICE

The instructions contained in this manual are not intended to cover all of the details or variations in equipment, or to provide for every possible contingency to be met in connection with installation, operation, or maintenance. Should further information be desired or particular problems arise which are not covered sufficiently for the purchaser's purposes, the matter should be referred to the local Toshiba sales office.

The contents of this instruction manual shall not become a part of or modify any prior or existing agreement, commitment, or relationship. The sales contract contains the entire obligation of Toshiba International Corporation's UPS Division. The warranty contained in the contract between the parties is the sole warranty of Toshiba International Corporation's UPS Division and any statements contained herein do not create new warranties or modify the existing warranty.

Any electrical or mechanical modifications to this equipment, without prior written consent of Toshiba International Corporation, will void all warranties and may void UL/CUL listing. Unauthorized modifications also can result in personal injury, death, or destruction of the equipment.

UNINTERRUPTIBLE POWER SYSTEM - BATTERY CABINET SYSTEM

If additional information or technical assistance is required call Toshiba's Customer Support Center toll free at 1-877-867-8773 or write to: Toshiba International Corporation, 13131 W. Little York Rd., Houston, TX 77041-9990.

Please complete the following information for your records and keep this manual with the equipment:

Model Number: _____

Serial Number: _____

Date of Installation: _____

Inspected By: _____

Table of Contents

LIST OF FIGURES	ii
LIST OF TABLES	ii
GENERAL SAFETY INSTRUCTIONS	1
IMPORTANT SAFETY INSTRUCTIONS	2
IMPORTANT BATTERY SAFETY INSTRUCTIONS	3
1.0 INSPECTION / STORAGE / DISPOSAL	5
1.1 INSPECTION OF THE NEW BATTERY SYSTEM	5
1.2 STORAGE OF BATTERY EQUIPMENT	5
1.3 DISPOSAL	5
2.0 PRECAUTIONS	6
2.1 INSTALLATION PRECAUTIONS	6
2.2 PRESTART PRECAUTIONS	6
2.3 OPERATING PRECAUTIONS	7
3.0 UPS POWER CONNECTIONS	7
3.1 UPS INPUT VOLTAGE	7
3.2 CONNECTING MULTIPLE BATTERY CABINETS	7
3.3 BATTERY CABINET POWER CABLING	8
3.4 BATTERY CABINET COMMUNICATION (RS-232) CABLING	8
4.0 CONNECTION INSTRUCTIONS AND DIAGRAMS	9
4.1 BATTERY CONNECTIONS	9
4.2 CABLE UPS TO BATTERY CABINET(S)	10
4.3 CHARGER CONNECTION NOTE	11
5 ENABLE UPS EXTERNAL BATTERY PARAMETERS	11
6.0 REMOTE ON/OFF	11
6.1 REMOTE ON/ OFF (FIGURE 2)	11
6.2 EPO OPERATION	11
7.0 EMERGENCY POWER OFF (EPO)	12
7.1 EPO CABLING	12
7.2 EPO OPERATION	12
8.0 PREVENTIVE AND SCHEDULED MAINTENANCE / PART REPLACEMENT	12
8.1 PREVENTIVE MAINTENANCE	12
8.2 PARTS REPLACEMENT	12
8.3 POWER CABLES	13
9 BATTERY REPLACEMENT	13
9.1 HOT-SWAPPABLE	13
9.0 EXTERNAL LAYOUTS / DIMENSIONS / SHIPPING WEIGHTS	15
9.1 EXTERNAL LAYOUTS	15
9.2 DIMENSIONS	15
9.3 SHIPPING WEIGHTS	15

10.0	1600XPI SYSTEM BACKUP RUNTIME	16
------	-------------------------------------	----

List of Figures

Figure 1	UPS Power Connections	7
Figure 2	RS232 Plugs on Battery Cabinet	8
Figure 3	Cabling 8/10kVA UPS to Battery Cabinet(s)	8
Figure 4	Cabling 14/18/22kVA UPS to Battery Cabinet.....	9
Figure 5	Cabling 8/10kVA UPS to Battery Cabinet.....	10

List of Tables

Table 1	Battery Pack Information.....	2
Table 2	Battery Type and Quantity	4
Table 3	UPS-Battery Cabinet Compatability Chart.....	6
Table 4	1600XPi Parameter Settings for H3B-BC-1825.....	11
Table 5	Field Service Replaceable Parts.....	13
Table 6	Battery Cabinet Dimensions	15
Table 7	Battery Cabinet Shipping Weight.....	15

GENERAL SAFETY INSTRUCTIONS

Warnings in this manual appear in any of four ways:

- 1) *Danger*- The danger symbol is a lightning bolt mark enclosed in a triangle which precedes the 3/16-inch high letters spelling the word "DANGER". The danger symbol is used to indicate imminently hazardous situations, locations, and conditions which, if not avoided, WILL result in death, serious injury, and/or severe property damage.



DANGER

- 2) *Warning*- The warning symbol is an exclamation mark in a triangle which precedes the 3/16-inch high letters spelling the word "WARNING". The warning symbol is used to indicate potentially hazardous situations and conditions which, if not avoided COULD result in serious injury or death. Severe property damage COULD also occur.



WARNING

- 3) *Caution*- The caution symbol is an exclamation mark enclosed in a triangle which precedes the 3/16-inch high letters spelling the word "CAUTION". The caution symbol is used to indicate potentially hazardous situations and conditions which, if not avoided may result in injury. Equipment damage may also occur.



CAUTION

- 4) *Attention warnings*- The attention warning symbol is an exclamation mark enclosed in a triangle which precedes the 3/16-inch high letters spelling the word "ATTENTION". The Attention warning symbol is used to indicate situations and conditions that can cause operator injury and/or equipment damage.



ATTENTION

Other warning symbols may appear along with the *Danger* and *Caution* symbol and are used to specify special hazards. These warnings describe particular areas where special care and/or procedures are required in order to prevent serious injury and possible death:

- 1) *Electrical warnings*- The electrical warning symbol is a lightning bolt mark enclosed in a triangle. The Electrical warning symbol is used to indicate high voltage locations and conditions that may cause serious injury or death if the proper precautions are not observed:



- 2) *Explosion warnings*- The explosion warning symbol is an explosion mark enclosed in a triangle. The Explosion warning symbol is used to indicate locations and conditions where molten, exploding parts may cause serious injury or death if the proper precautions are not observed:



IMPORTANT SAFETY INSTRUCTIONS

SAVE THESE INSTRUCTIONS

This manual contains important instructions that should be followed during installation and maintenance of the Battery System model **H3B-BC-1825**.

The maximum ambient temperature in which a Battery System should be operated is 104 °F (40 °C).

The nominal battery voltage for the battery cabinet is as follows:

Model	Voltage
H3B-BC-1825	288 VDC

Table 1 Battery Pack Information

Battery Pack Data	
Battery Packs	Designed for battery acid leakage containment with (6) batteries per pack.
Battery Pack Size HxWxD (max)	5 in. (127 mm) x 7.3 in. (185 mm) x 18.2 in. (462 mm)
Battery Pack Quantity	12
Battery Type	Lead Acid 9A/12V (FR)
Toshiba Part Number for Battery Pack	51896-FS
Battery Pack Construction	Battery pack case is ABS plastic No. 7



CAUTION

Misuse of this equipment could result in human injury and equipment damage. In no event will Toshiba Corporation be responsible or liable for either indirect or consequential damage or injury that may result from the misuse of this equipment.



CAUTION

Do not dispose of the batteries in a fire. The batteries may explode.



CAUTION

Do not open or mutilate the batteries. Released electrolyte is harmful to the eyes and skin and could also be toxic.



WARNING

This unit contains sealed lead acid batteries. Lack of preventative maintenance could result in batteries exploding and emitting gasses and/or flame. An authorized, trained technician must perform annual preventative maintenance.



WARNING

Failure to replace a battery before it becomes exhausted may cause the case to crack, possibly releasing electrolytes from inside the battery, and resulting in secondary faults such as odor, smoke, and fire.



WARNING

Installation and servicing of batteries should be performed by personnel knowledgeable of batteries and the required precautions. Keep unauthorized personnel away from the batteries.

IMPORTANT BATTERY SAFETY INSTRUCTIONS



WARNING

Proper maintenance to the battery system of this unit must be done by a qualified service technician. This is essential to the safety and reliability of your UPS system. Refer to service manual.



DANGER

A battery can present a risk of electrical shock and high short circuit current.

The following precautions should be observed when working with batteries.

- 1) Verify that the UPS is off and that the power cord is disconnected from the power source.
- 2) Remove watches, rings or other metal objects.
- 3) Use tools with insulated handles to prevent inadvertent shorts.
- 4) Wear rubber gloves and boots.
- 5) Do not lay tools or metal parts on top of batteries.
- 6) Determine if the battery is inadvertently grounded. If inadvertently grounded, remove source of ground. **Contact with any part of a grounded battery can result in electrical shock.** The likelihood of such shock will be reduced if such grounds are removed during installation and maintenance.
- 7) Verify circuit polarities prior to making connections.
- 8) Disconnect charging source and load prior to connecting or disconnecting terminals.
- 9) VRLA batteries may emit highly flammable hydrogen gas. During charging and operation. Do not smoke, cause or spark in the immediate area of the batteries. This includes static electricity from the body.
- 10) Do not attempt to open the batteries in order to add water or sample the specific gravity of the electrolyte. The batteries are valve regulated lead acid type and such servicing is not possible without damaging the battery.
- 11) Use proper lifting means when moving batteries and wear all appropriate safety clothing and equipment.
- 12) Do not dispose of lead acid batteries except through channels in accordance with local, state and federal regulations.

INSTRUCTIONS IMPORTANTES CONCERNANT LA SÉCURITÉ

CONSERVER CES INSTRUCTIONS

Cette notice contient des instructions importantes concernant la sécurité



ATTENTION

Un battery peut présenter un risque de choc électrique, de brûlure par transfert d'énergie.

ATTENTION

Por le remplacement, utiliser le même nombre de batteries du modèle suivant.

Table 2 Battery Type and Quantity

Model Capacity	Type	Battery Pack Quantity	Battery Quantity
H3B-BC-1825	Lead Acid 9AH/12V (FR)	12	72



ATTENTION

L'élimination des batteries est règlementée. Consulter les codes locaux à cet effet.

1.0 Inspection / Storage / Disposal

1.1 Inspection of the New Battery System

Upon receipt of the Battery System, a careful inspection for shipping damage should be made.

- 1) Check the unit for loose, broken, bent or otherwise damaged parts. If damage has occurred during shipment, keep all original crating and packing materials for return to the shipping agent. The equipment warranty will not apply to units which are damaged during shipment.
- 2) Check to see that the rated capacity and the model number specified on the nameplate conform to the order specifications.

1.2 Storage of Battery Equipment

If the Battery System is to be subjected to long or short term storage, the following guidelines should be used.

Avoid:

- 1) Storage in sites subject to extreme changes in temperature or high humidity.
- 2) Storage in sites subject to exposure of high levels of dust or metal particles.
- 3) Storage on inclined floor surfaces or in sites subject to excessive vibration.

Before storing:

- 1) Charge the system's batteries.
- 2) Place the Battery System's input switch (MCCB-C) in the OFF position.

Storing:

- 1) Store within a temperature range of -4 to 104 °F (-20 to 40 °C).
- 2) For best results, store the Battery System in the original shipping container and place on a wood or metal pallet.
- 3) The optimum storage temperature is 70 °F (21 °C). Higher ambient temperatures cause UPS batteries to need recharging more frequently.
- 4) If stored in an ambient temperature under 68 °F (20 °C); recharge the batteries every 9 months.
- 5) If stored in an ambient temperature of 68 to 86 °F (20 to 30 °C); recharge the batteries every 6 months.
- 6) If stored in an ambient temperature of 86 to 104 °F (30 to 40 °C); recharge the batteries every 3 months.

1.3 Disposal

Please contact your state environmental agency for details on disposal of electrical components and packaging in your particular area.

It is illegal to dump lead-acid batteries in landfills or dispose of improperly. Please help our Earth by contacting the environmental protection agencies in your area, the battery manufacturer, or call Toshiba toll-free at (877) 867-8773 for more information about recycling.

2.0 Precautions

2.1 Installation Precautions



- 1) Install the unit in a well ventilated location; allow at least 10 cm (4 inches) on all sides for air ventilation and maintenance.
- 2) Install the unit in a stable, level, and upright position, which is free of vibration.
- 3) Install the unit where the ambient temperature is within the correct operating range.
- 4) Do not install the Battery System in a location that is subject to high humidity.
- 5) Do not install the unit at sites that are exposed to direct sunlight.
- 6) Do not install the Battery System in areas which are subject to high levels of contamination by airborne dust, metal particles, or flammable gases.
- 7) Avoid installation near sources of electrical noise. Always make sure that the unit ground is intact to prevent electrical shock and to help reduce electrical noise.
- 8) Do not install where water or any foreign objects/substances may get inside the Battery System.

2.2 Prestart Precautions



- 1) Before connecting the Battery System to the UPS verify that the two are compatible by comparing them to the following chart.

Table 3 UPS-Battery Cabinet Compatibility Chart

UPS Model Number	Battery Cabinet Model Number	Battery Voltage
H3BG2L080C61T	H3B-BC-1825	288VDC
H3BG2L100C61T		
H3BG2L140C61T		
H3BG2L180C61T		
H3BG2L220C61T		



WARNING DO NOT attempt to connect if the Model numbers do not match the above chart. This will result in damage to the UPS, the Battery System, or both. Call your Toshiba representative if you should have any questions.

- 2) Before connecting the Battery System to the UPS; switch the ON/OFF switch MCCB2, located on the rear panel of the battery system to the **OFF** position. (See Sections 4 & 5)

2.3 Operating Precautions



- 1) The UPS should not be powered up until the entire operation manual has been reviewed.

3.0 UPS Power Connections

The following illustration shows the wiring connections from the power distribution panel (not part of the UPS) to the UPS, and from the UPS to the battery cabinet. This connection diagram is to be used with the H3B-BC-1825 Battery Units (Hereafter known as BC-1825).

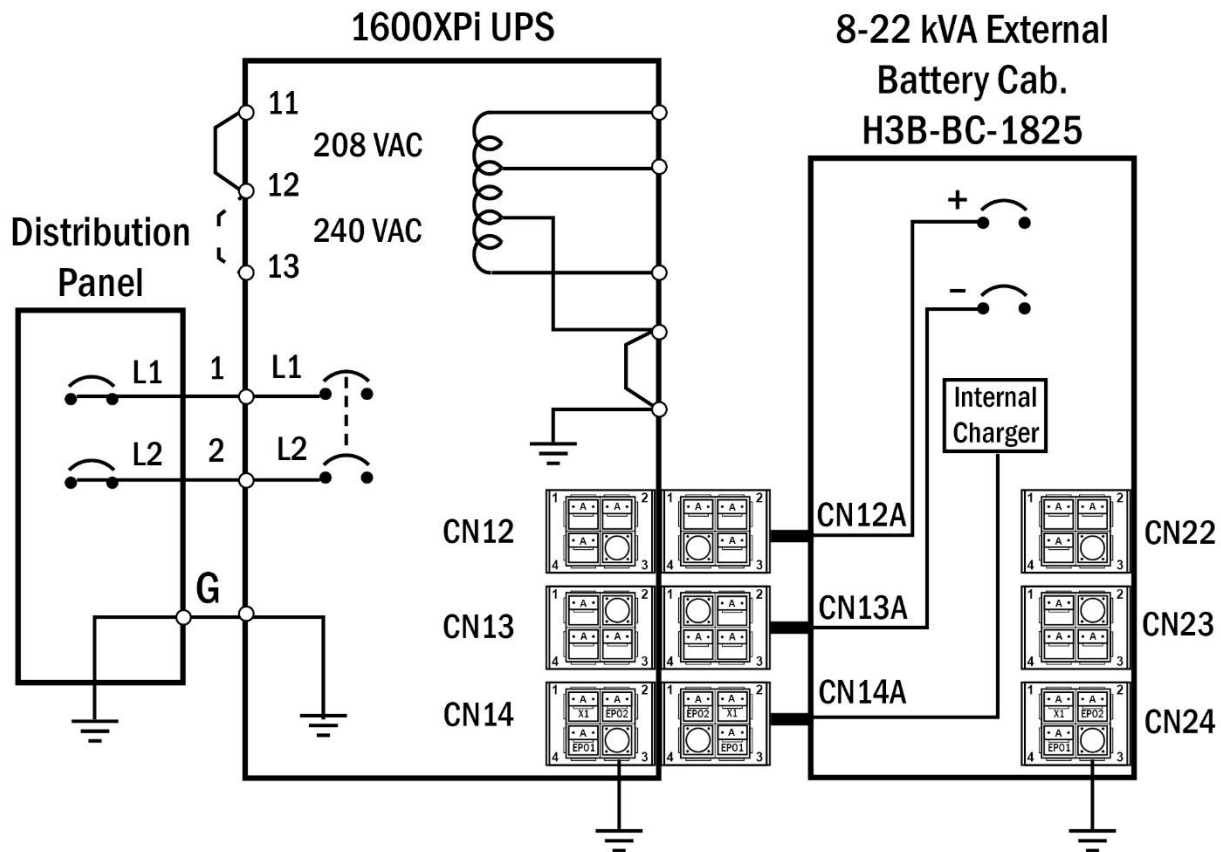

Figure 1 UPS Power Connections

3.1 UPS Input Voltage

208V In: If the UPS AC input power is 208 V rated, connect a jumper wire between terminals 11 and 12 on the UPS terminal block. DO NOT jumper terminal 13 to 11 or 12. The UPS ships from the factory with the jumper in the 208 V position.

240 V In: If the UPS AC input power is 240 V rated, connect a jumper wire between terminals 12 and 13 on the UPS terminal block. DO NOT jumper terminal 11 to 12 or 13.

3.2 Connecting Multiple Battery Cabinets

Up to two (2) BC-1825 battery cabinets may be connected in parallel with the UPS. See Figure 3, and Sections 4 and 5.

3.3 Battery Cabinet Power Cabling

The battery cabinets ship with six-foot long connection cables. Contact Toshiba Customer Support at 1-877-867-8773 if longer cables are required for your application, or if additional cables or connectors are required.

3.4 Battery Cabinet Communication (RS-232) Cabling

The 1600XPi BC-1825 can be remotely monitored by the UPS by connecting the UPS RS-232 port to the BC-1825(s) as shown below.

There is also a provision for adding an external remote shutdown.

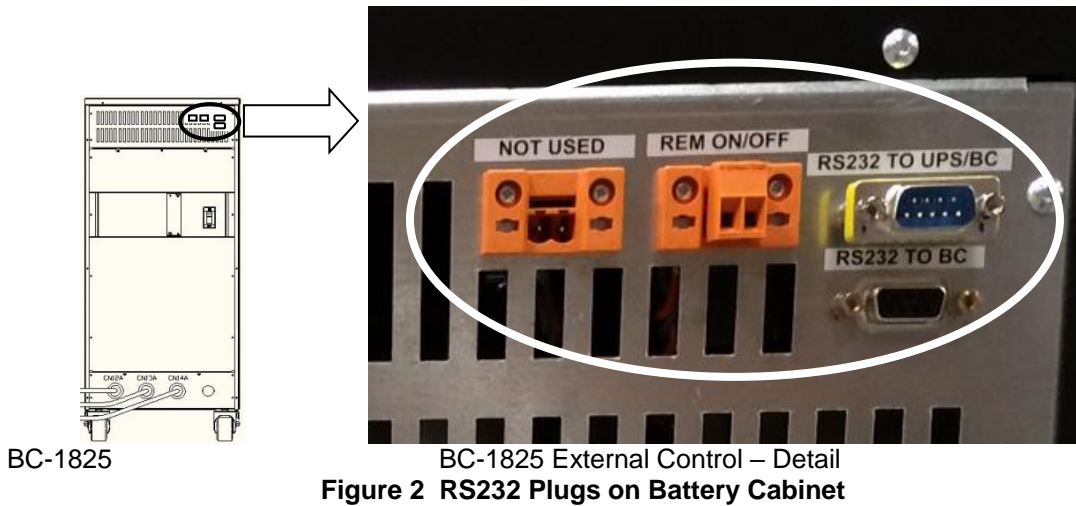

BC-1825 External Control – Detail
Figure 2 RS232 Plugs on Battery Cabinet

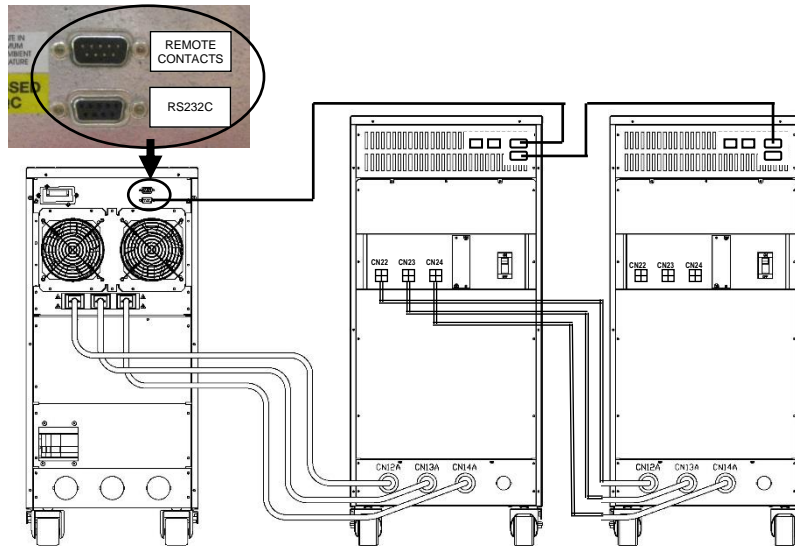

Figure 3 Cabling 8/10kVA UPS to Battery Cabinet(s)

4.0 Connection Instructions and Diagrams

4.1 Battery Connections

The following illustration shows the wiring connections between the UPS and the battery cabinet.



DANGER

Contacts are not rated with interrupting capacity. Ensure the MCCB switch on the rear panel of the Battery Unit is set to the **OFF** position before connecting the UPS to the battery cabinet.

The following diagrams shows the rear view of the 8/10kVA and 14/18/22 kVA UPS with a BC-1825 battery cabinet. **NOTE:** Use only **compatible** cabinets! See page 6.

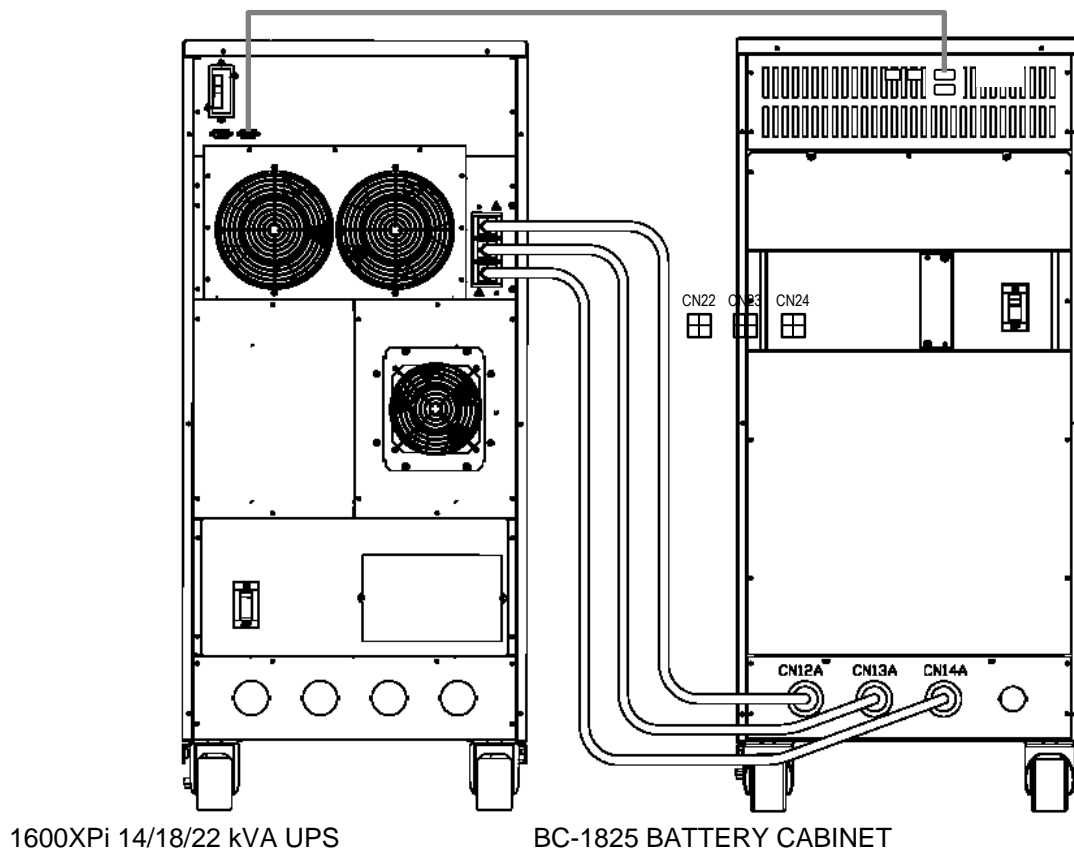

Figure 4 Cabling 14/18/22kVA UPS to Battery Cabinet

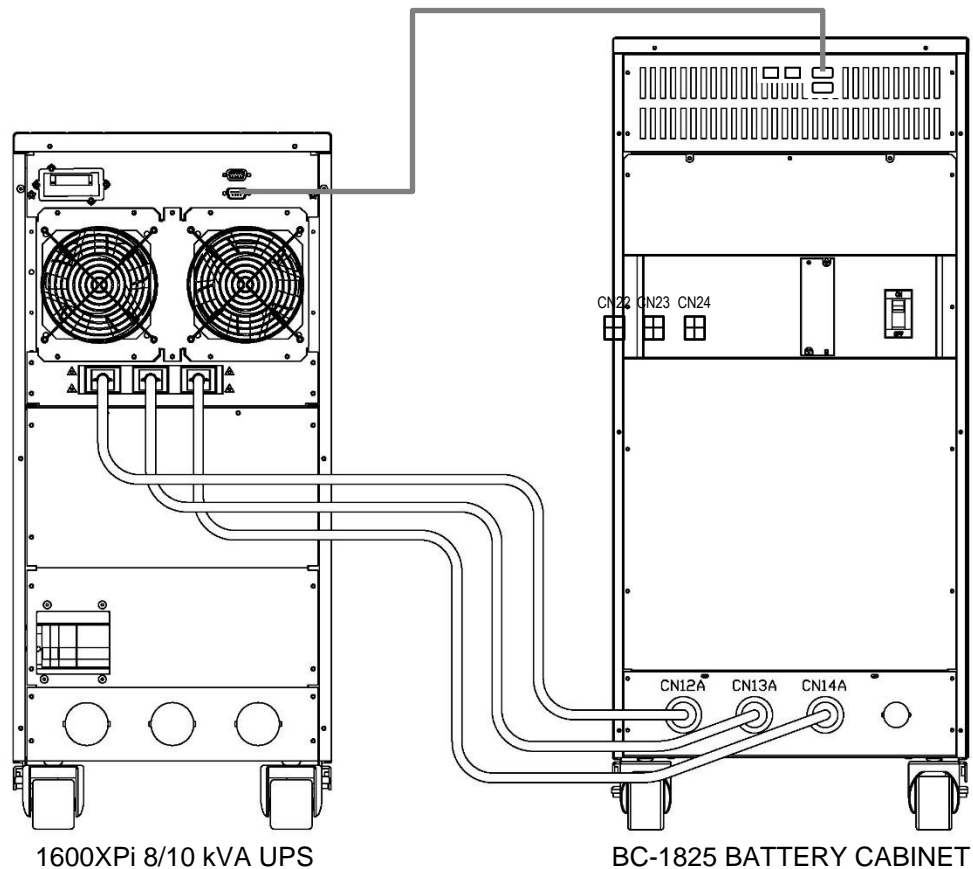

Figure 5 Cabling 8/10kVA UPS to Battery Cabinet

4.2 Cable UPS to Battery Cabinet(s)

Connect up to two (2) battery cabinets to the UPS as shown in Figure 3 and Figure 4.

1. Ensure all power is locked and tagged out.
2. Remove the battery connector cover mounted on the UPS back panel.

To connect the first battery cabinet to the UPS

3. Connect the RS232 cable from the Battery Cabinet 1 **RS232 to UPS/BC** port to the UPS **RS232C** port. (Figure 3)
4. Connect Battery Cabinet 1 **CN12A** to UPS **CN12**,
5. Connect Battery Cabinet 1 **CN13A** to UPS **CN13**,
6. Connect Battery Cabinet 1 **CN14A** to UPS **CN14**.

If a second battery cabinet is to be installed go to step 7, otherwise go to Section 4.3.

7. Connect the RS232 cable from the Battery Cabinet 2 **RS232 to UPS/BC** port to the Battery Cabinet 1 **RS232 to BC** port. (Figure 3)
8. Connect Battery Cabinet 2 **CN12A** to cabinet 1 **CN22**,
9. Connect Battery Cabinet 2 **CN13A** to cabinet 1 **CN23**,
10. Connect Battery Cabinet 2 **CN14A** to cabinet 1 **CN24**.

4.3 Charger Connection Note

The Battery cabinet model BC-1825 requires a 240 Vac connection between the UPS and battery cabinet for battery charging. This connection is made from CN14A of the battery cabinet to CN14 of the UPS (and CN14A of battery cabinet 2 to CN24 of battery cabinet 1 if paralleling cabinets). **NOTE: Without this connection the battery cabinet will not be able to charge its batteries.**

5 Enable UPS External Battery Parameters

Set the UPS external battery parameters 222 and 223 to enable battery string monitoring of the external battery cabinet(s).

1. Power on the UPS and Battery Cabinet(s).
2. Follow the instructions in the 1600XPi manual, 60616, to log in as Administrator.
3. Press the **SETTING** tab, then press **Batt** on the touchscreen.
4. Use the <<, <, >, and >> buttons to navigate to the parameters 522, 523, and 525-527. Entering parameters 528 and 529 is optional (See Table 1 below).
5. Touch the parameter on the touchscreen to select it for editing. See the UPS manual 60616. Set per the following table.

Table 4 1600XPi Parameter Settings for H3B-BC-1825

Parameter	Description	UPS Only	UPS + 1 BC ¹	UPS + 2 BC ¹
522 Enable BC1	Enable External Batt. Cabinet 1	Disable	Enable	Enable
523 Enable BC2	Enable External Batt. Cabinet 2)	Disable	Disable	Enable
524 External BC Status	External Battery Cabinet Status	0	1	1
525 No Ex Batt(Series)	Number of External Batt. Packs in Series String	0	24	24
526 No Ex Batt(Paral)	Number of External Batt. Strings in Parallel	0	3	6
527 Ex Batt Rated Ahr	External Battery Capacity in A-hr	0	9	9
528 Ex Batt C Rate ¹	External Battery Cabinet Charge/Discharge Rate	0	2	2
529 Ex Batt Ins Date ¹	External Battery Installation Date (e.g YYYYMMDD)	N/A	YYYYMMDD	YYYYMMDD

1 – Parameter is informational only. Value is not used in calculations

6. Model BC-1825 requires a 240 Vac connection between the UPS and battery cabinet for battery charging. This connection is made from CN14A of the battery cabinet to CN14 of the UPS (and CN14A of battery cabinet 2 to CN24 of battery cabinet 1 if paralleling cabinets). **NOTE: Without this connection the battery cabinet will not be able to charge its batteries.**

6.0 Remote ON/OFF

6.1 Remote ON/ OFF (Figure 2)

The Battery Cabinet does not have an EPO. The EPO on the UPS connects to the battery cabinet through the **battery cabinet connection cable** between CN14 and CN14A. No other battery cabinet connection is needed.

6.2 EPO Operation

Pressing the EPO will cause the breaker on the battery cabinet and the UPS, to switch to the OFF position simultaneously, disabling both the battery cabinet and the UPS.

The DC breaker on the battery cabinet is provided with a shunt trip. This device is operated with an applied voltage of 120 Vac (**supplied from the UPS**). When the EPO is pressed the UPS applies 120V to the shunt trip, causing the breaker to switch to the OFF position.

7.0 Emergency Power Off (EPO)

7.1 EPO Cabling

The Battery Cabinet does not have an EPO. The EPO on the UPS connects to the battery cabinet through the **battery cabinet connection cable** between CN14 and CN14A. No other battery cabinet connection is needed.

7.2 EPO Operation

Pressing the EPO will cause the breaker on the battery cabinet and the UPS, to switch to the OFF position simultaneously, disabling both the battery cabinet and the UPS.

The DC breaker on the battery cabinet is provided with a shunt trip. This device is operated with an applied voltage of 120 Vac (**supplied from the UPS**). When the EPO is pressed the UPS applies 120V to the shunt trip, causing the breaker to switch to the OFF position.

8.0 Preventive and Scheduled Maintenance / Part Replacement

8.1 Preventive Maintenance

Toshiba's 1600XPi Series of UPS battery cabinets have been designed to provide years of trouble-free operation requiring a minimum of preventive maintenance.

The best preventive measure that the battery cabinet user can take is to keep the area around the unit, particularly the air inlet vents, clean and free of moisture and dust accumulations. If the atmosphere of the installation site is very dusty, use a vacuum cleaner to periodically remove dust accumulations from the air inlet vents. Schedule authorized service centers to perform internal parts inspections annually.



CAUTION Before performing any maintenance, the technician should become familiar with and follow the important safety instructions on pages 1–4.



WARNING Proper maintenance of the battery system of this unit by factory authorized personnel is essential to the safety and reliability of your battery cabinet system. Refer to service manual.

8.2 Parts Replacement

The following list shows intervals for periodic maintenance and replacement of certain UPS parts.

Batteries: VRLA batteries are maintenance free with respect to electrolyte only. The charging voltage, temperature, performance and connection resistance must be checked periodically. Necessary corrective actions must be made in order to assure safe reliable power is supplied by the battery cabinet. Charging voltage, storage/operating temperature, charging cycles, and connection resistance all affect battery life.

The recommended battery replacement interval is 3 to 5 years. All of the batteries must be replaced at the same time.

Monthly Maintenance

A. Visual Checks:

1. Leakage
2. Corrosion on positive terminal

B. Check battery temperature at the negative terminal.

- C. Measure and record the system float charging voltage.
- D. Measure and record the individual unit's battery tray voltage.

Semi-Annual maintenance

- A. Repeat the monthly checks.
- B. Perform a 10-second high rate (e.g. 100 amp) load test on the individual batteries.
- C. Re-torque all inter-battery connecting hardware (if applicable).
- D. Perform inter-battery connector resistance checks.

Table 5 Field Service Replaceable Parts

Component*	Function	Rating	Part No.
FU1, FU2	Control Power Fuses	500 V, 10 A	00649
Battery Tray Fuse	Internal Battery tray Fuse	500 V, 40 A	00637
Battery Pack	Replaceable Battery Pack	-	51896-FS

* Field Service replaceable parts only.

8.3 Power Cables

The three battery cabinet connector cables (battery positive, battery negative, and battery charger) are each equipped with individually keyed Anderson connectors to prevent cross connecting the battery cabinet and UPS circuitry.

The battery cabinet connector cables are six (6) foot in length.

9 Battery Replacement

9.1 Hot-Swappable

The battery packs can be replaced while the UPS is in On-Line or Bypass mode without removing power from the critical loads.



CAUTION

If a power failure occurs as the battery pack is being removed/inserted or occurs during the period batteries are out of the circuit, the unit will try to go to Backup (without battery) and would thus drop the load. It would also arc/spark between the battery and chassis connections if going to Backup as the tray is pulled.

To perform a hot swap of the battery packs:

1. Open the 1600XPi Battery Cabinet front door.
2. Loosen the battery retaining plate screws and remove the battery pack retaining plate(s).



CAUTION

Each battery pack weighs approximately 40 lb (18 kg).

Dropping or uncontrolled handling of the battery pack may result in personal injury or damage to the UPS or battery pack.

Use two-handed or two person lift to handle each battery pack. Maintain horizontal orientation of the battery pack with setting it down.

3. Slowly draw out each battery pack half-way, then support the bottom of the pack as the pack is drawn out of its receptacle.
4. Place the old battery pack aside.
5. Lift the new battery pack using the same technique described above to slide the battery pack half-way into the battery pack receptacle.

Ensure the battery pack is oriented right-side up.

6. Slowly slide the battery pack the rest of the way into the receptacle.

- 6.1. If oriented correctly, the battery pack will slide all the way into the battery pack receptacle, and a faint but audible click can be heard when the rear connectors mate.
- 6.2. If the battery pack does not slide smoothly back completely into the receptacle, remove it and verify the battery pack is not upside down.
- 6.3. Notify the factory if the battery pack still will not fully seat in the receptacle, and a cause cannot be determined.
7. Repeat steps 3-6 for remaining battery packs.
8. Reinstall battery pack retaining plates.
9. Close the 1600XPi Battery Cabinet front door.

9.0 External Layouts / Dimensions / Shipping Weights

9.1 External Layouts

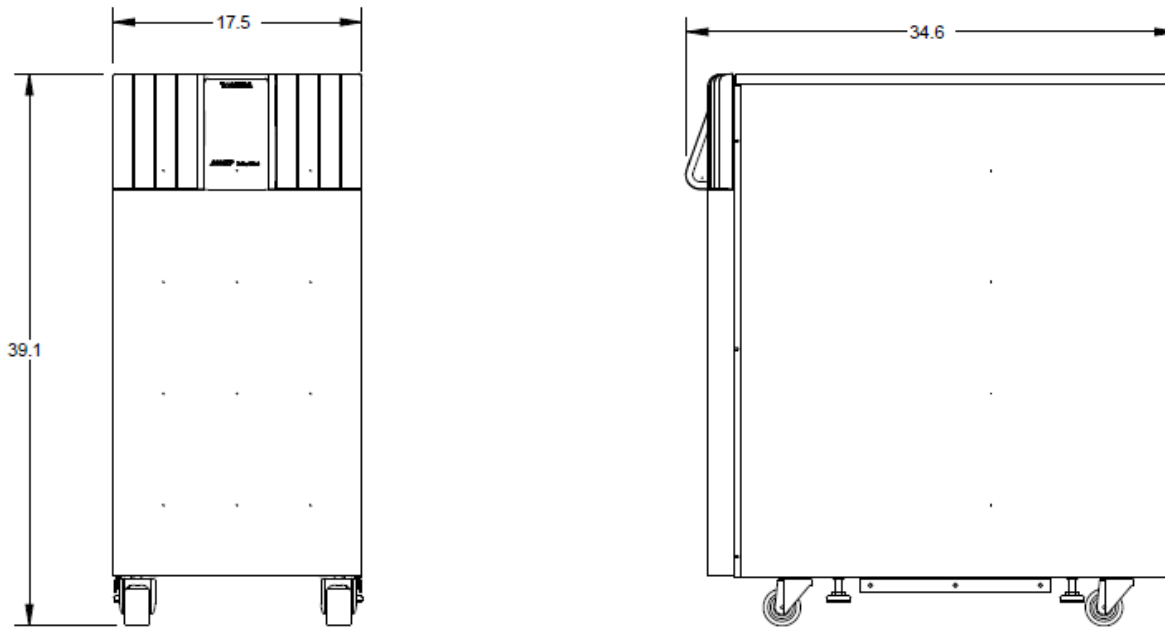

9.2 Dimensions

Table 6 Battery Cabinet Dimensions

Model	H	W	D
H3B-BC-1825	39.1 in.(992 mm)	17.5 in.(445 mm)	34.6 in. (880 mm)

9.3 Shipping Weights

Table 7 Battery Cabinet Shipping Weight

Model	Pounds	Kilograms
H3B-BC-1825	780 lbs.	354 kg

10.0 1600XPi System Backup Runtime

The following runtime table gives the approximate combined backup runtimes at different load levels for 1600XPi UPS models equipped with one and two battery cabinets.

NOTE: These values are approximate and are dependent on many variables including operating environment, age of the batteries, battery temperature, and discharge history.

The load levels are given as a percent of rated load with 0.85 power factor.

Table 1: Estimated Runtime of UPS with Battery Cabinet at Various Loads

		Rated Load (0.85 PF)	100%	90%	80%	70%	60%	50%	40%	30%	20%	10%
UPS plus One Battery Cabinet	1600XPi 8 kVA		44	48	53	60	70	82	105	120	180	>300*
	1600XPi 10 kVA		35	40	44	50	57	70	82	105	150	>300*
	1600XPi 14 kVA		30	35	40	45	53	63	78	98	150	>300*
	1600XPi 18 kVA		21	24	28	35	42	50	60	82	112	240
	1600XPi 22 kVA		16	18	21	26	32	42	51	65	98	165
UPS plus Two Battery Cabinets	1600XPi 8 kVA		72	82	90	105	120	135	165	240	>300*	>300*
	1600XPi 10 kVA		60	65	72	86	98	112	135	180	>300*	>300*
	1600XPi 14 kVA		51	55	63	72	82	98	120	150	240	>300*
	1600XPi 18 kVA		40	45	50	55	65	78	90	120	165	>300*
	1600XPi 22 kVA		30	36	42	46	53	63	82	105	150	>300*

* Estimated Runtime Exceeds 300 minutes.

TOSHIBA

TOSHIBA INTERNATIONAL CORPORATION
SOCIAL INFRASTRUCTURE SYSTEMS GROUP
POWER ELECTRONICS DIVISION

13131 West Little York Rd., Houston, TX 77041

Tel: 713/466-0277 Fax 713/466-8773

US 877-867-8773 Canada 800/872-2192 Mexico 01/800/527-1204

www.toshiba.com/tic/industrial/uninterruptible-power-systems

Printed in the U.S.A.