

TOSHIBA



HX7 ADJUSTABLE SPEED DRIVE

Programming and Operation Manual

Document Number: 61131-000

Date: July, 2008

HX7 Adjustable Speed Drive

Programming and Operation Manual

Document Number: 61131-000

Date: July, 2008



Introduction

Congratulations on the purchase of the new **HX7 Adjustable Speed Drive (ASD)**. The **HX7 ASD** is an 18-pulse PWM drive designed for use with 3-phase AC induction motors. This 18 pulse design includes an 18 pulse phase-shifting autotransformer input with a diode bridge rectifier.

U.S. Patent 6396723.

Japan Patent pending 2000-179543.

The drive has been designed with an 18-pulse input transformer to assist in the compliance of the harmonic distortion limits of standard IEEE 519 1992 at the point of common coupling.

The **HX7 ASD** is ideally suited to drive variable torque loads. Toshiba's technology, quality, and reliability enables the motor to develop high torque and provide compensation for motor slip, which results in smooth, quick starts and highly efficient operation. The **HX7 ASD** uses digitally-controlled pulse width modulation. The programmable functions may be accessed via the easy-to-use menu. These features, combined with Toshiba's high-performance software, delivers unparalleled motor control and reliability.

The **HX7 ASD** is a very powerful tool, yet surprisingly simple to operate. The user-friendly easy-to-read 240 x 64 pixel graphical LCD screen of the **Electronic Operator Interface (EOI)** provides quick access to the many monitoring and programming features of the **HX7 ASD**. The motor control software is menu-driven, which allows for easy access to the motor control parameters and quick changes when required.

To maximize the abilities of your new **HX7 ASD**, a working familiarity with this manual will be required. This manual has been prepared for the **HX7 ASD** installer, operator, and maintenance personnel.

This manual may also be used as a reference guide or for training. With this in mind, use this manual to develop a system familiarity before attempting to install or operate the device.

The **HX7 ASD** is truly **Reliability in motion**.

Important Notice

The instructions contained in this manual are not intended to cover all details or variations in equipment types. Nor may it provide for every possible contingency concerning the installation, operation, or maintenance of this equipment. Should additional information be required contact your Toshiba representative.

The contents of this manual shall not become a part of or modify any prior or existing agreement, commitment, or relationship. The sales contract contains the entire obligation of Toshiba International Corporation. The warranty contained in the contract between the parties is the sole warranty of Toshiba International Corporation and any statements contained herein do not create new warranties or modify the existing warranty.

Any electrical or mechanical modifications to this equipment without prior written consent of Toshiba International Corporation will void all warranties and may void the UL/CUL listing or other safety certifications. Unauthorized modifications may also result in a safety hazard or equipment damage.

Misuse of this equipment could result in injury and/or equipment damage. In no event will Toshiba Corporation be responsible or liable for direct, indirect, special, or consequential damage or injury that may result from the misuse of this equipment.

About This Manual

This manual was written by the Toshiba Technical Publications Group. This group is tasked with providing technical documentation for the **HX7 Adjustable Speed Drive**. Every effort has been made to provide accurate and concise information to you, our customer.

At Toshiba we're continuously searching for better ways to meet the constantly changing needs of our customers. E-mail your comments, questions, or concerns about this publication to the Technical-Publications-Dept@tic.toshiba.com.

Manual's Purpose and Scope

This manual provides information on how to program and operate your **HX7 Adjustable Speed Drive**. The information provided in this manual is applicable to the **HX7 Adjustable Speed Drive** only.

See the drawing package and the *W7 ASD Installation and Operation Manual* provided with the system for ratings information as it pertains to your **HX7 Adjustable Speed Drive**. Read the *W7 ASD Installation and Operation Manual* completely and review the items of the drawing package for installation and connectivity applicables before applying power, programming, or operating the **HX7 Adjustable Speed Drive**.

This programming and operation manual provides information on the various features and functions of this powerful cost-saving device, including system operation, configuration, and menu options.

Included is a section on general safety instructions that describe the warning labels and symbols that are used throughout the manual. Read the manual completely before operating, performing maintenance, or disposing of this equipment.

This manual should be considered a permanent part of the equipment and should be readily available for reference and review.

Because of our commitment to continuous improvement, Toshiba International Corporation reserves the right, without prior notice, to update information, make product changes, or to discontinue any product or service identified in this publication.

Toshiba International Corporation (TIC) shall not be liable for direct, indirect, special, or consequential damages resulting from the use of the information contained within this manual.

This manual is copyrighted. No part of this manual may be photocopied or reproduced in any form without the prior written consent of Toshiba International Corporation.

© Copyright 2008 Toshiba International Corporation.

TOSHIBA[®] is a registered trademark of the Toshiba Corporation. All other product or trade references appearing in this manual are registered trademarks of their respective owners.

Reliability in motion[®] is a registered trademark of the Toshiba Corporation.

All rights reserved.

Printed in the U.S.A.

Table of Contents

General Safety Information.....	1
Safety Alert Symbol.....	1
Signal Words.....	1
Special Symbols.....	2
Equipment Warning Labels.....	2
Qualified Personnel.....	2
Equipment Inspection.....	3
Handling and Storage.....	3
Disposal.....	3
Personnel Protection.....	4
System Setup Requirements.....	4
Operational and Maintenance Precautions.....	6
Service Life Information.....	6
I/O and Control.....	7
Input Control Signals and Monitoring.....	8
I/O Terminal Descriptions.....	9
HX7 ASD Control.....	12
CNU1/1A and CNU2/2A Pinout.....	13
CN3 Pinout.....	13
CN7 Pinout.....	13
I/O Circuit Configurations.....	14
Typical Connection Diagram.....	15
Startup and Test.....	16
Electronic Operator Interface.....	17
EOI Features.....	17
EOI Operation.....	18
System Operation.....	19
Operation (Local).....	19
Default Setting Changes.....	19
Startup Wizard Requirements.....	21
Command Mode and Frequency Mode Control.....	24
Command Control (F003).....	24
Frequency Control (F004).....	25
Command and Frequency Control Selections.....	26
Override Operation.....	27
Command and Frequency-Control Override Hierarchy.....	27
Command Control Selections.....	27
Frequency Control Selections.....	28
System Configuration and Menu Options.....	29
Root Menus.....	29
Frequency Command Screen.....	29
Monitor Screen.....	30
Program Mode.....	32
Direct Access Parameter Information.....	45
Direct Access Parameters/Numbers.....	45

Alarms, Trips, and Troubleshooting	168
Alarms and Trips	168
Alarms	169
User Notification Codes	171
Trips/Faults.....	172
Viewing Trip Information.....	176
Clearing a Trip	176

General Safety Information

DO NOT attempt to operate, program, perform maintenance, or dispose of this equipment until you have read and understood all of the product safety information and directions that are contained in this manual and those of the *W7 ASD Installation and Operation Manual*.

Safety Alert Symbol

The **Safety Alert Symbol** indicates that a potential personal injury hazard exists. The symbol is comprised of an equilateral triangle enclosing an exclamation mark.



Signal Words

Listed below are the signal words that are used throughout this manual followed by their descriptions and associated symbols. When the words **DANGER**, **WARNING** and **CAUTION** are used in this manual they will be followed by important safety information that must be carefully adhered to.

The word **DANGER** preceded by the safety alert symbol indicates that an imminently hazardous situation exists that, if not avoided, will result serious injury to personnel or loss of life.



The word **WARNING** preceded by the safety alert symbol indicates that a potentially hazardous situation exists that, if not avoided, could result in serious injury to personnel or loss of life.



The word **CAUTION** preceded by the safety alert symbol indicates that a potentially hazardous situation exists which, if not avoided, may result in minor or moderate injury.



The word **CAUTION** without the safety alert symbol indicates a potentially hazardous situation exists which, if not avoided, may result in equipment and property damage.

CAUTION

Special Symbols

To identify special hazards, other symbols may appear in conjunction with the **DANGER**, **WARNING** and **CAUTION** signal words. These symbols indicate areas that require special and/or strict adherence to the procedures to prevent serious injury to personnel or death.

Electrical Hazard Symbol

A symbol which indicates a hazard of injury from electrical shock or burn. It is comprised of an equilateral triangle enclosing a lightning bolt.



Explosion Hazard Symbol

A symbol which indicates a hazard of injury from exploding parts. It is comprised of an equilateral triangle enclosing an explosion image.



Equipment Warning Labels

Warning labels that are attached to the equipment will include the exclamation mark within a triangle. **DO NOT** remove or cover any of these labels. If the labels are damaged or if additional labels are required, contact your Toshiba sales representative for additional labels.

Labels attached to the equipment are there to provide useful information or to indicate an imminently hazardous situation that may result in serious injury, severe property and equipment damage, or death if safe procedures or methods are not followed as outlined in this manual.

Qualified Personnel

Installation, operation, and maintenance shall be performed by **Qualified Personnel Only**. A **Qualified Person** is one that has the skills and knowledge relating to the construction, installation, operation, and maintenance of the electrical equipment and has received safety training on the hazards involved (Refer to the latest edition of NFPA 70E for additional safety requirements).

Qualified Personnel shall:

- Have carefully read the entire operation manual.
- Be familiar with the construction and function of the HX7 ASD, the equipment being driven, and the hazards involved.
- Be able to recognize and properly address hazards associated with the application of motor-driven equipment.
- Be trained and authorized to safely energize, de-energize, ground, lockout/tagout circuits and equipment, and clear faults in accordance with established safety practices.
- Be trained in the proper care and use of protective equipment such as safety shoes, rubber gloves, hard hats, safety glasses, face shields, flash clothing, etc., in accordance with established safety practices.
- Be trained in rendering first aid.

For further information on workplace safety visit www.osha.gov.

Equipment Inspection

- Upon receipt of the equipment inspect the packaging and equipment for shipping damage.
- Carefully unpack the equipment and check for parts that were damaged during shipping, missing parts, or concealed damage. If any discrepancies are discovered, it should be noted with the carrier prior to accepting the shipment, if possible. File a claim with the carrier if necessary and immediately notify your Toshiba sales representative.
- **DO NOT** install or energize equipment that has been damaged. Damaged equipment may fail during operation resulting in equipment damage or personal injury.
- Check to see that the rated capacity and the model number specified on the nameplate conform to the order specifications.
- Modification of this equipment is dangerous and must not be performed except by factory trained representatives. When modifications are required contact your Toshiba sales representative.
- Inspections may be required before and after moving installed equipment.
- Keep the equipment in an upright position.
- Contact your Toshiba sales representative to report discrepancies or for assistance if required.

Handling and Storage

- Use proper lifting techniques when moving the HX7 ASD; including properly sizing up the load, getting assistance, and using a forklift if required.
- Store in a well-ventilated covered location and preferably in the original carton if the equipment will not be used upon receipt.
- Store in a cool, clean, and dry location. Avoid storage locations with extreme temperatures, rapid temperature changes, high humidity, moisture, dust, corrosive gases, or metal particles.
- The storage temperature range of the HX7 ASD is 32° to 104° F (0° to 40° C).
- **DO NOT** store the unit in places that are exposed to outside weather conditions (i.e., wind, rain, snow, etc.).
- Store in an upright position.

Disposal

Never dispose of electrical components via incineration. Contact your state environmental agency for details on disposal of electrical components and packaging in your area.

Personnel Protection

- Installation, operation, and maintenance shall be performed by **Qualified Personnel Only**.
- A thorough understanding of the HX7 ASD will be required before the installation, operation, or maintenance of the HX7 ASD.



- Rotating machinery and live conductors can be hazardous and shall not come into contact with humans. Personnel should be protected from all rotating machinery and electrical hazards at all times.
- Insulators, machine guards, and electrical safeguards may fail or be defeated by the purposeful or inadvertent actions of workers. Insulators, machine guards, and electrical safeguards are to be inspected (and tested where possible) at installation and periodically after installation for potential hazardous conditions.
- **DO NOT** allow personnel near rotating machinery. Warning signs to this effect shall be posted at or near the machinery.
- **DO NOT** allow personnel near electrical conductors. Human contact with electrical conductors can be fatal. Warning signs to this effect shall be posted at or near the hazard.
- **DO NOT** attempt to configure the system to use the **Dynamic Braking** function. This system is not equipped to support the use of the **Dynamic Braking** function. Attempts to configure the system to use the **Dynamic Braking** function may result in system damage and/or injury to personnel.
- Personal protection equipment shall be provided and used to protect employees from any hazards inherent to system operation.
- Follow all warnings and precautions and do not exceed equipment ratings.

System Setup Requirements

- When using the HX7 ASD as an integral part of a larger system, it is the responsibility of the HX7 ASD installer or maintenance personnel to ensure that there is a fail-safe in place (i.e., an arrangement designed to switch the system to a safe condition if there is a fault or failure).
- System safety features should be employed and designed into the integrated system in a manner such that system operation, even in the event of system failure, will not cause harm or result in personnel injury or system damage (i.e., E-Off, Auto-Restart settings, System Interlocks, etc.).
- The programming setup and system configuration of the HX7 ASD may allow it to start the motor unexpectedly. A familiarity with the Auto-restart settings are a requirement to use this product.
- There may be thermal or physical properties, or ancillary devices integrated into the overall system that may allow for the HX7 ASD to start the motor without warning. Signs at the equipment installation must be posted to this effect.
- Power factor improvement/correction capacitors or surge absorbers **MUST NOT** be installed on the output of the HX7 ASD.
- Use of the built-in system protective features is highly recommended (i.e., E-Off, Overload Protection, etc.).
- The operating controls and system status indicators should be clearly readable and positioned where the operator can see them without obstruction.

- Additional warnings and notifications shall be posted at the equipment installation location as deemed required by **Qualified Personnel**.
- Follow all warnings and precautions and do not exceed equipment ratings.



CAUTION

- If a secondary magnetic contactor (MC) or an ASD output disconnect is used between the HX7 ASD and the load, it should be interlocked to halt the HX7 ASD before the secondary contact opens. If the output contactor is used for bypass operation, it must be interlocked such that commercial power is never applied to the HX7 ASD output terminals (U, V, W).
- When using an ASD output disconnect, the ASD and the motor must be stopped before the disconnect is either opened or closed. Closing the output disconnect while the 3-phase output of the ASD is active may result in equipment damage or injury to personnel.

Operational and Maintenance Precautions

WARNING

- Turn off, lockout, and tag out the main power, the control power, and instrumentation connections before inspecting or servicing the drive, or opening the door of the enclosure.
- Turn off, lockout, and tag out the main power, the control power, and instrumentation connections before proceeding to disconnect or connect the power wiring to the equipment.
- The capacitors of the HX7 ASD maintain a residual charge for a period of time after turning off the ASD. The required time for each ASD typeform is indicated with a cabinet label and a **Charge LED**. Wait for at least the minimum time indicated on the enclosure-mounted label and ensure that the **Charge LED** has gone out before opening the door of the ASD once the ASD power has been turned off.
- Turn the power on only after attaching (or closing) the front cover and **DO NOT** remove the front cover of the HX7 ASD when the power is on.
- **DO NOT** attempt to disassemble, modify, or repair the HX7 ASD. Call your Toshiba sales representative for repair information.
- **DO NOT** place any objects inside of the HX7 ASD.
- If the HX7 ASD should emit smoke or an unusual odor or sound, turn the power off immediately.
- The heat sink and other components may become extremely hot to the touch. Allow the unit to cool before coming in contact with these items.
- Remove power from the HX7 ASD during extended periods of non-use.
- The system should be inspected periodically for damaged or improperly functioning parts, cleanliness, and to ensure that the connectors are tightened securely.

Service Life Information

Part Name	Service Life	Remarks
Large Capacity Electrolytic Capacitor	5 Years	When not used for long periods, charge semi-annually.
Cooling Fan	26,000 Hours	
CN Connectors	100 Connects/Disconnects	
On-board Relays	500,000 Actuations	

I/O and Control

The **HX7 Adjustable Speed Drive** may be set up initially by performing a few simple configuration settings. To operate properly, the ASD must be securely mounted and connected to a power source (3-phase AC input at the **L1/R**, **L2/S**, and **L3/T** terminals). The control terminals of the ASD may be used by connecting the terminals of the **Terminal Board** to the proper sensors or signal input sources (see the section titled [Input Control Signals and Monitoring on pg. 8](#)).

The output terminals of the ASD (**T1/U**, **T2/V**, and **T3/W**) must be connected to the motor that is to be controlled (see [Figure 14 on pg. 15](#)).

As a minimum, the installation of the ASD shall conform to **Article 110** of the **2008 NEC**, the **Occupational Safety and Health Administration** requirements, and to any other local and regional industry codes and standards.

See the *W7 ASD Installation and Operation Manual* for specifics of the 3-phase input/output and the system grounding requirements.

Input Control Signals and Monitoring

The HX7 ASD can be controlled by several input types and combinations thereof, as well as operate within a wide range of output frequency and voltage levels. This section discusses the HX7 ASD control methods and supported I/O functions.

The **Terminal Board** (P/N 48570) supports discrete and analog I/O functions and is shown in [Figure 2 on pg. 11](#). [Table 1](#) lists the names, descriptions, and the default settings (of programmable terminals) of the input and output terminals of the **Terminal Board**.

Note: To use the input lines of the **Terminal Board** to provide **Run** commands the **Command Mode** setting must be set to **Terminal Block**.

[Figure 14 on pg. 15](#) shows the basic connection diagram for the HX7 ASD system.

Table 1. Terminal Board default terminal name assignments and functions.

Terminal Name	Input/Output	Terminal Function (default setting if programmable)	Circuit Config.
ST	Discrete Input Connect to CC to activate (Sink mode).	Standby — Multifunctional programmable discrete input. Activation required for normal ASD operation.	Figure 4 on pg. 14.
RES		Reset — Multifunctional programmable discrete input.	
F		Forward — Multifunctional programmable discrete input.	
R		Reverse — Multifunctional programmable discrete input.	
S1		Preset Speed 1 — Multifunctional programmable discrete input.	
S2		Preset Speed 2 — Multifunctional programmable discrete input.	
S3		Preset Speed 3 — Multifunctional programmable discrete input.	
S4		Emergency Off — Multifunctional programmable discrete input.	
OUT1	Switched Output	Low Speed — Multifunctional programmable discrete output.	Figure 10 on pg. 14.
OUT2		Reach Frequency — Multifunctional programmable discrete output.	
FLC		Fault Relay — Common.	Figure 13 on pg. 14.
FLB		Fault Relay — Normally closed contact.	
FLA		Fault Relay — Normally open contact.	
RR	Analog Input	Frequency Mode 1 — Multifunctional programmable analog input. (0.0 to 10 volt input — 0 Hz to Maximum Frequency).	Figure 5 on pg. 14.
RX		Unassigned — Multifunctional programmable analog input (-10 to +10 VDC input — Unassigned).	Figure 6 on pg. 14.
II		Frequency Mode 2 — Multifunctional programmable analog input (4 [0] to 20 mADC input).	Figure 7 on pg. 14.
VI		Frequency Mode 2 — Multifunctional programmable analog input (0 to 10 VDC input).	
AM	Analog Output	Output Current — Produces an output current that is proportional to the magnitude of the function assigned to this terminal.	Figure 12 on pg. 14
FM		Output Frequency — Same as AM terminal.	
P24	DC Output	24 VDC @ 50 mA max. output.	Figure 8 on pg. 14.
PP		PP — 10.0 VDC @ 10 mA max. output to be used with an external potentiometer.	Figure 9 on pg. 14.
FP	Pulsed Output	Output Frequency — an output pulse train that has a frequency which is based on the output frequency of the ASD.	Figure 11 on pg. 14.
CC	—	Control common (Do Not connect to Earth Gnd).	
All terminals reference CC.			

I/O Terminal Descriptions

Note: The programmable terminal assignments may be accessed and changed from their default settings as mapped on pg. 40 or via the **Direct Access** method: Program ⇒ Direct Access ⇒ **applicable parameter number**. See the section titled *Program Mode* on pg. 40 for the applicable **Direct Access** parameter numbers.

For further information on terminal assignments and default setting changes, see the sections titled *Default Setting Changes* on pg. 27 and *Terminal Selection Parameters* on pg. 42.

Note: See the section titled *Cable/Terminal Specifications* on pg. 185 for the HX7 ASD conductor and terminal electrical specifications.

ST — The default setting for this terminal is the **Standby** mode controller. As the default setting, this terminal must be activated for normal system operation. The **ST** terminal is activated by connecting **CC** to this terminal (Sink mode). When deactivated **OFF** is displayed at the EOI screen. This input terminal may be programmed to any of the functions that are listed in Table 6 on page 170 (see F113).

RES — The default setting for this terminal is **Reset**. The **RES** terminal is activated by connecting **CC** to this terminal (Sink mode). A momentary connection to **CC** resets the ASD and any fault indications from the display. **Reset** is effective when faulted only. This input terminal may be programmed to any of the functions that are listed in Table 6 on page 170 (see F114).

F — The default setting for this terminal is **Forward** run command. The **F** terminal is activated by connecting **CC** to this terminal (Sink mode). This input terminal may be programmed to any of the functions that are listed in Table 6 on page 170 (see F111).

R — The default setting for this terminal is **Reverse** run command. The **R** terminal is activated by connecting **CC** to this terminal (Sink mode). This input terminal may be programmed to any of the functions that are listed in Table 6 on page 170 (see F112).

S1 — The default setting for this terminal is **Preset Speed 1** (see *Preset Speed #1* on pg. 60). The **S1** terminal is activated by connecting **CC** to this terminal (Sink mode). This input terminal may be programmed to any of the functions that are listed in Table 6 on page 170 (see F115).

S2 — The default setting for this terminal is **Preset Speed 2** (see *Preset Speed #2* on pg. 60). The **S2** terminal is activated by connecting **CC** to this terminal (Sink mode). This input terminal may be programmed to any of the functions that are listed in Table 6 on page 170 (see F116).

S3 — The default setting for this terminal is **Preset Speed 3** (see *Preset Speed #3* on pg. 61). The **S3** terminal is activated by connecting **CC** to this terminal (Sink mode). This input terminal may be programmed to any of the functions that are listed in Table 6 on page 170 (see F117).

S4 — The default setting for this terminal is **Emergency Off** (normally closed). The **Emergency Off** terminal is activated by opening the connection to **CC** (Sink mode). The function of this input as **Emergency Off** is to remove power from the output of the ASD and may apply a supplemental braking system using the method selected at F603. This input terminal may be programmed to any of the functions that are listed in Table 6 on page 170 (see F118).

RR — The **Frequency Mode 1** function is assigned to this terminal. The **RR** terminal accepts a 0 – 10 VDC input signal and may be programmed to control the speed or torque of the motor. This input terminal setting may be fixed or the input may be varied as required for the application. The gain and bias of this terminal may be adjusted for application-specific suitability (see F210 – F215).

RX — The **RR** terminal accepts a ± 10 VDC input signal and may be programmed to control the speed or torque of the motor. This input terminal setting may be fixed or the input may be varied as required for the application. The gain and bias of this terminal may be adjusted for application-specific suitability (see F216 – F221).

VI — The **Frequency Mode 2** function is assigned to this terminal. The **VI** terminal accepts a 0 – 10 VDC input signal and may be programmed to control the speed or torque of the motor. This input terminal setting may be fixed or the input may be varied as required for the application and may not be used when using the **II** input. The gain and bias of this terminal may be adjusted for application-specific suitability (see F201 – F206).

II — The **Frequency Mode 2** function is assigned to this terminal. The **II** terminal accepts a 4 – 20 mA input signal and may be programmed to control the speed or torque of the motor. This input terminal setting may be fixed or the input may be varied as required for the application and may not be used when using the **VI** input. The gain and bias of this terminal may be adjusted for application-specific suitability (see F201 – F206).

P24 — +24 VDC @ 100 mA power supply for customer use.

PP — This terminal provides a 10 VDC output that may be divided using a potentiometer. The tapped voltage is applied to the **RR** input to provide manual control of the **RR** programmed function.

OUT1 — The default function assigned to this terminal is **Low Speed**. This output may be programmed to provide an indication (open or closed) that any one of the functions that are listed in [Table 8 on page 175](#) has occurred or is active. This function may be used to signal external equipment (e.g., activate the brake) (see F130). The **OUT1** terminal is rated at 2 A/120 VAC and 2 A/30 VDC.

OUT2 — The default function assigned to this terminal is **Reach Frequency**. This output may be programmed to provide an indication (open or closed) that any one of the functions that are listed in [Table 8 on page 175](#) has occurred or is active. This function may be used to signal external equipment (e.g., activate the brake) (see F131). The **OUT2** terminal is rated at 2 A/120 VAC and 2 A/30 VDC.

FP — The default function of this output terminal is to output a series of pulses at a rate that is a function of the output frequency of the ASD. As the output frequency of the ASD goes up so does the **FP** output pulse rate. This terminal may be programmed to provide an output pulse rate that is proportional to the magnitude of the user-selected item from [Table 7 on page 174](#) (see F676).

AM — This output terminal produces an output current that is proportional to the magnitude of the function assigned to this terminal. The available assignments for this output terminal are listed in [Table 7 on page 174](#). The default setting is **Output Current** (see F670).

FM — This output terminal produces an output current that is proportional to the magnitude of the function assigned to this terminal. The available assignments for this output terminal are listed in [Table 7 on page 174](#). The default setting is **Output Frequency** (see F005).

FLC — **FLC** is the common leg of a single-pole double-throw form C relay. The **FL** relay is the **Fault Relay** by default, but may be programmed to any of the selections of [Table 8 on page 175](#) (see F132 and [Figure 1](#)).

FLB — One of two contacts that, under user-defined conditions, connect to **FLC** (see [Figure 1](#)).

FLA — One of two contacts that, under user-defined conditions, connect to **FLC** (see [Figure 1](#)).

Note: The **FLA** and **FLC** contacts are rated at 2A/250 VAC. The **FLB** contact is rated at 1A/250 VAC.

Figure 1. FLA, FLB, and FLC switching contacts shown in the de-energized state.

Note: The relay is shown in the **Faulted** or de-energized condition. During normal system operation the relay connection is **FLC-to-FLA**.

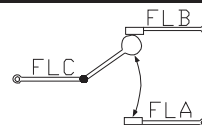
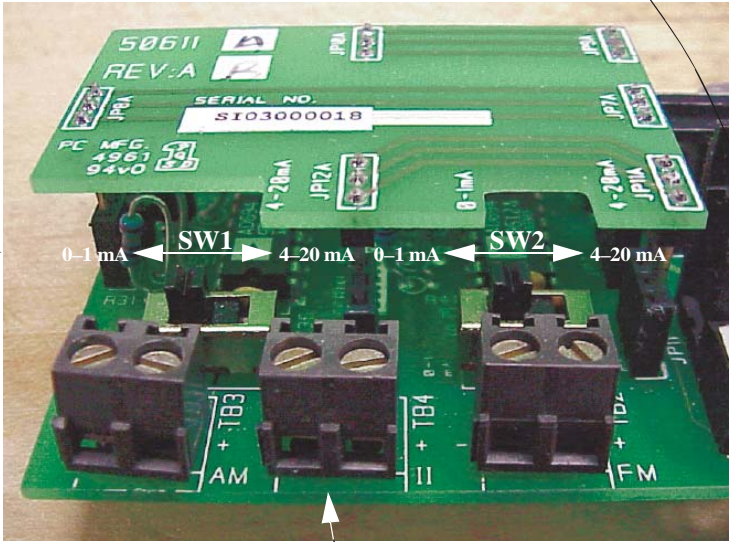
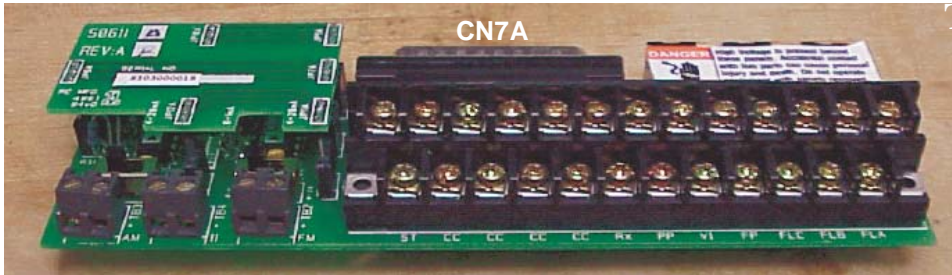

Figure 2. Terminal Board.



SW1 and SW2 may be switched to change the full-scale reading of the AM (TB3) and FM (TB2) output terminals. See F005 and F670 for more information on the AM and FM terminals.

II Terminals

TB1 input and output terminals of the Terminal Board.



HX7 ASD Control

The Control Board (P/N 56000) serves as the primary control source for the HX7 ASD and may receive control input from the **Terminal Board**, an **Option Card**, **RS232/RS485 Communications**, or the **HX7 EOI**.

The **Control Board** supports: Multiple Protocol Communications and the ability to communicate in either half- or full-duplex modes.

Using the optional multiple-protocol communications interface: the ASD-NANOCOM, the Control Board may be configured for the type of communications protocol being received and respond appropriately to the sending device. The ASD-NANOCOM connects to the **J4** and **J5** connectors (see [Figure 3](#)). A jumper board (P/N 55365) is required at the **J4** connector if not using the ASD-NANOCOM.

The **ASD-NANOCOM** must be setup to support the desired communications protocol via Program ⇒ **Comm Settings**. Consult the **ASD-NANOCOM** User's Manual (P/N 10572-1.000-000) for a complete listing of the setup requirements.

Half or Full duplex communications is available when using RS232/RS485 communications. The jumpers at the JP1 and the JP2 connectors may be moved from one position to the other to facilitate either half- or full-duplex operation. If no jumpers are used the system will operate in the full duplex mode.

For more information on the HX7 ASD communication requirements, please visit www.tic.toshiba.com/ind to acquire a copy of the **7-Series Serial Communications** User Manual (P/N 53840) (see Drives ⇒ G7 Severe Duty Industrial ⇒ **Manuals**) and www.iccdesigns.com to acquire a copy of the **ASD-NANOCOM** User Manual.

Contact your Toshiba representative if more information is required on the **ASD-NANOCOM**.

Figure 3. Control Board of the HX7 ASD (P/N 56000).

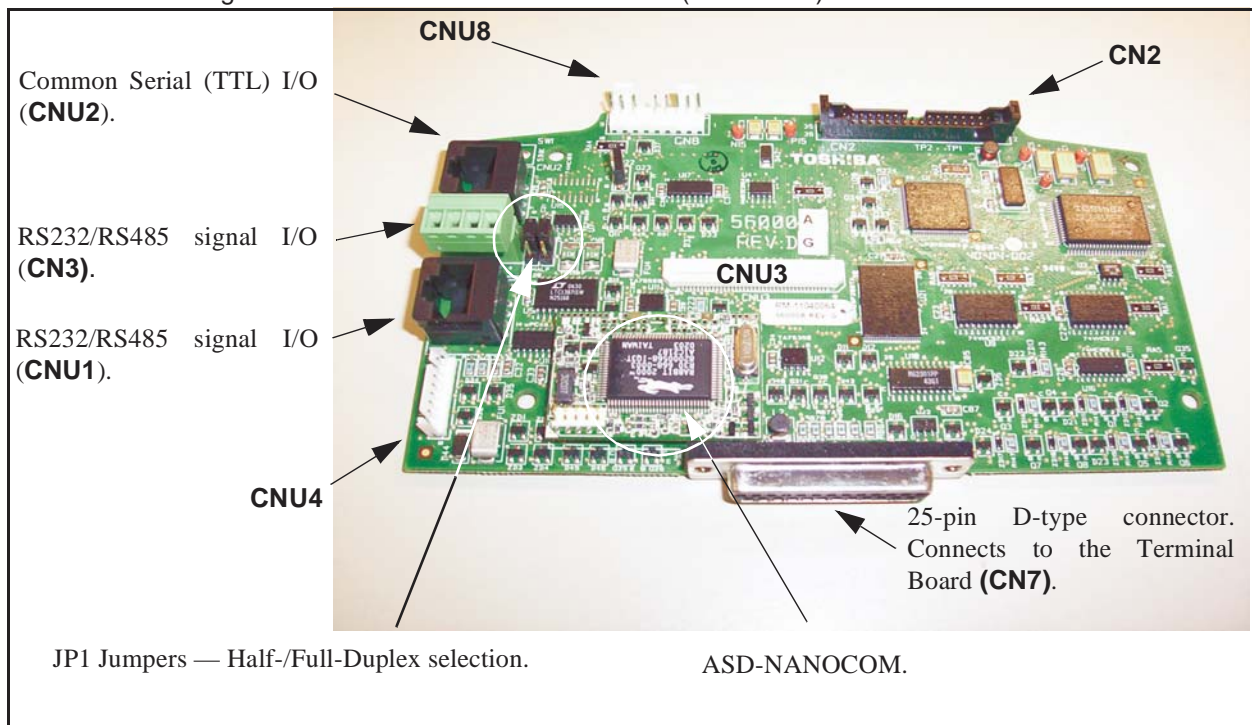

CNU1/1A and CNU2/2A Pinout

Control Board CNU1/1A and CNU2/2A pinout (RJ-45 connectors).

Pin #	CNU1 Pinout (Control Board)	CNU1A Pinout (EOI)	Pin #	CNU2 Pinout (Control Board)	CNU2A Pinout (EOI)
1	P24	P24	1	P24	P24
2	Gnd	Gnd	2	Gnd	Gnd
3	Tx (-)	RXA	3	Rx	Tx
4	Rx (+)	TXA	4	Gnd	Gnd
5	Rx (-)	TXB	5	Tx	Rx
6	Tx (+)	RXB	6	Gnd	Gnd
7	RS232/RS485	CNU3 Pin-7	7	Open	Open
8	Gnd	Gnd	8	Gnd	Gnd

CN3 Pinout

CN3 of the Control Board is used for 2-wire RS485 serial communications.

Pin Number	CN3 Pinout (Controller PCBA)
1	RS485 Signal +
2	RS485 Signal -
3	RS485 Signal Gnd.
4	Shield

Note: CNU2 or CNU3 may be used for RS485 communication — Cannot use both simultaneously.

CN7 Pinout

CN7 of the Control Board connects to CN7A of the **Terminal Board**.

Table 2. CN7 pinout assignments. Programmable terminals are listed as their default settings.

Pin Number	Function	Pin Number	Function
1	PP	14	II
2	FL	15	S1
3	VI	16	R
4	RR	17	S3
5	FM	18	S2
6	RX	19	N15
7	FP	20	S4
8	AM	21	P15
9	*OUT1	22	P24
10	*OUT2	23	CC
11	ST	24	CC
12	RES	25	CC
13	F	—	—

Note: * Open collector outputs.

I/O Circuit Configurations

<p>Figure 4. Discrete Input.</p> <p>Configured Sink (may be configured Source)</p>	<p>Figure 5. RR Input.</p> <p>33k Input Impedance</p>
<p>Figure 6. RX Input.</p> <p>69k Input Impedance</p>	<p>Figure 7. VI/II Input.</p> <p>33k Input Impedance</p> <p>500Ω Input Impedance</p> <p>VI and II inputs may not be used simultaneously.</p>
<p>Figure 8. P24 Output.</p> <p>24 VDC 50 mA Max.</p> <p>Fuse resets after high current is removed.</p>	<p>Figure 9. PP Output.</p> <p>10 VDC (output) 10 mA Max.</p> <p>4.7µF</p>
<p>Figure 10. OUT1/OUT2 Output.</p> <p>2A/250VAC</p> <p>OUT1/OUT2</p>	<p>Figure 11. FP Output.</p> <p>1 to 43.2 KHz 50 mA max.</p> <p>Programmable Input</p>
<p>Figure 12. FM/AM Output.</p> <p>10 VDC Max. 20 mA Max.</p> <p>0.1µF</p> <p>4.7k</p> <p>Low Pass Filter Circuit</p> <p>Programmable</p>	<p>Figure 13. Fault Relay (active fault).</p> <p>2A/250VAC</p> <p>1A/250VAC</p> <p>2A/250VAC</p> <p>Programmable Input</p>

Typical Connection Diagram

Figure 14. HX7 ASD typical connection diagram.

Note: When connecting multiple wires to the PA, PB, PC, or PO terminals, do not connect a solid wire and a stranded wire to the same terminal.

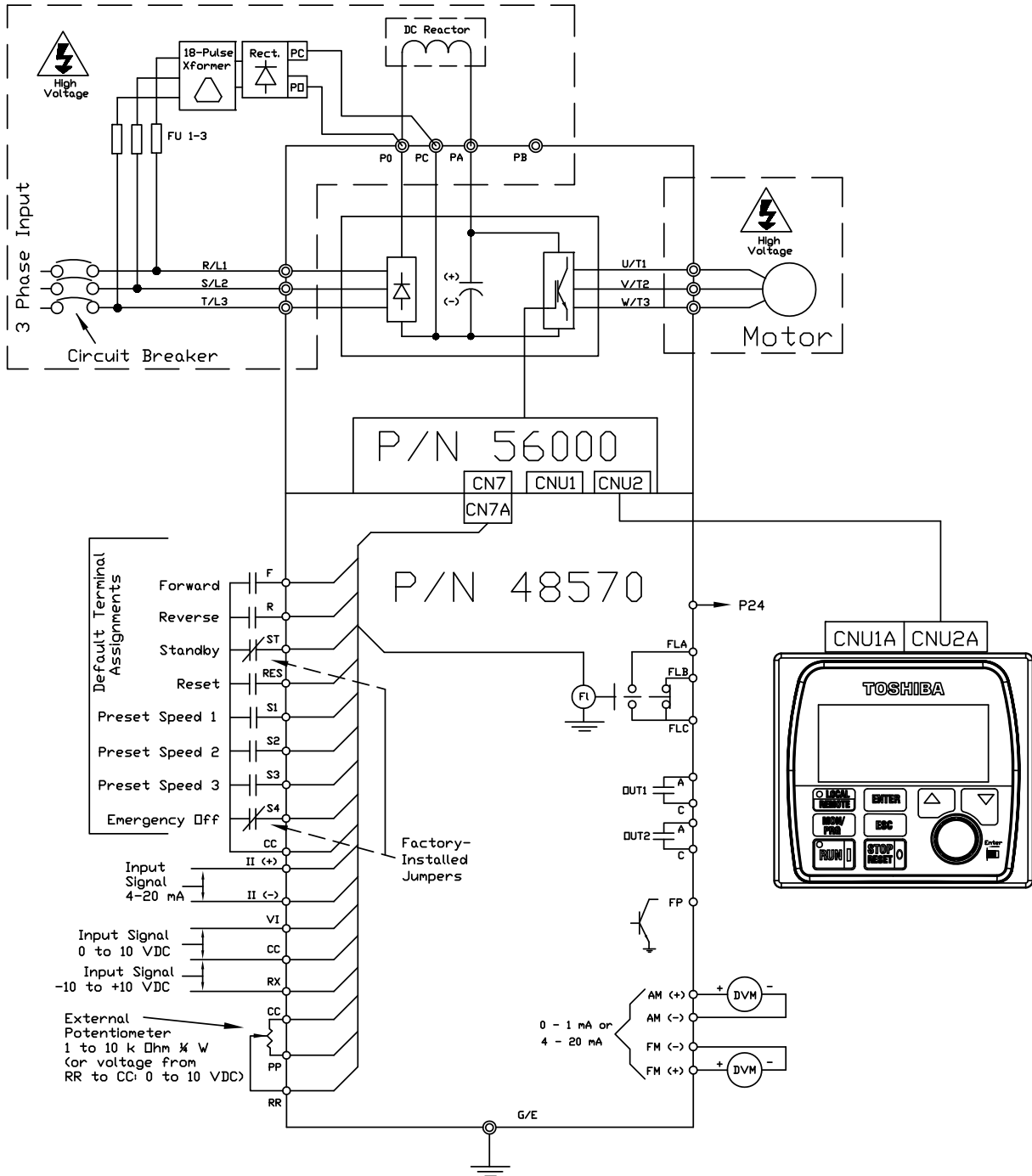

DO NOT CONNECT CC TO EARTH GROUND.

Startup and Test

Before turning on the ASD ensure that:

- **R/L1, S/L2, and T/L3** are connected to the 3-phase input power.
- **U/T1, V/T2, and W/T3** are connected to the motor.
- The 3-phase input voltage is within the specified tolerance.
- There are no shorts and all grounds are secured.
- All personnel are at a safe distance from the motor and the motor-driven equipment.

Electronic Operator Interface

The **HX7 ASD Electronic Operator Interface (EOI)** is comprised of an LCD display, two LEDs, a rotary encoder, and eight keys. These items are described below and their locations are provided in [Figure 15 on pg. 17](#).

The **EOI** can be mounted remotely from the ASD as described in the section titled [EOI Remote Mounting on pg. 27](#). The dimensional requirements for remote mounting is also found there. Using a screw length that exceeds the specified dimensions may cause deformation of the outer surface of the bezel as shown in [Figure 20 on pg. 29](#) and should be avoided.

The interface can operate up to distances of 15 feet from the ASD via the Common Serial (TTL) Port. For distances beyond 15 feet, the RS232/RS485 port is recommended.

EOI Features

Figure 15. The HX7 ASD Electronic Operator Interface.

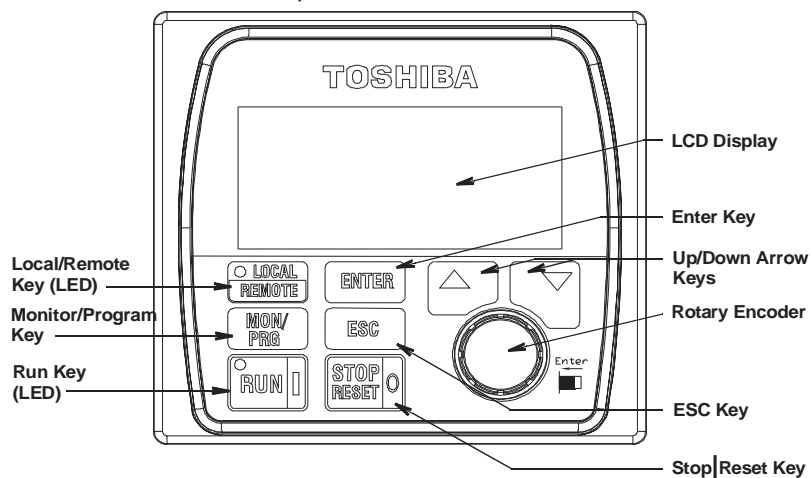

LCD Display — Displays configuration information, performance data (e.g., motor frequency, bus voltage, output power, etc.), and diagnostic information.

Enter Key — Selects a menu item to be changed or accepts and records the changed data of the selected field (same as pressing the **Rotary Encoder**).

Up Key — Increases the value of the selected parameter or scrolls up the menu listing (continues during press-and-hold).

Down Key — Decreases the value of the selected parameter or scrolls down the menu listing (continues during press-and-hold).

Rotary Encoder — Functions as the **Up** key, the **Down** key, and the **Enter** key. Turn the **Rotary Encoder** either clockwise or counterclockwise to perform the **Up** or **Down** key functions. Press the **Rotary Encoder** to perform the **Enter** function. Press the **Rotary Encoder** while turning to increase the effectiveness of the **Rotary Encoder**. The Up/Down-Clockwise/Counter Clockwise **Rotary Encoder** relationship to menu changes may be changed via Program ⇒ EOI Options ⇒ Encoder Action ⇒ **Encoder Direction (UP)** (Up may be set to clockwise or counter clockwise).

ESC Key — Returns to the previous level of the menu tree, toggles between the **Panel** screen and the **Frequency Command** screens, or cancels changes made to a field if pressed while still in the reverse video mode (dark background/light text). The 3 functions are menu-specific.

Stop/Reset Key — If pressed once while in the **Local** mode issues the **Off** command and stops the motor at the programmed deceleration rate. If pressed twice in rapid succession — either initiates an **Emergency Off** or resets the ASD if faulted.

Local|Remote Key — Toggles the system to and from the **Local** and **Remote** modes. The LED is on when the system is in the **Local Command** mode.

The **Local Command** mode enables the **Command** and **Frequency** control functions to be carried out via the **EOI**.

The **Remote** mode enables the **Command** and **Frequency** control functions to be carried out via any one of the following methods:

- F003/F004 settings,
- Pulse Input,
- Motorized Pot,
- Communication Card,
- RS232/RS485,
- Common TTL,
- Binary/BCD,
- LED Keypad,
- Option Card RX2,
- RX,
- RR, or
- VI/II.

The input channel selection may be made via Program ⇒ Utilities ⇒ **CMD, FRQ, & Carrier**.

MON/PRG Key (Monitor/Program) — Provides a means to access the three root menus. Pressing the **MON/PRG** key repeatedly loops the system through the three root menus (see [Figure 20 on pg. 37](#)). While looping through the root menus, the **Program** menu will display the last menu screen or sub-menu item being accessed at the time that the **MON/PRG** key was pressed.

Run Key — Issues the **Run** command while in the **Local** mode. The Run LED is red while running and green while stopped. A **Run** command issued from the **EOI** while in the **Remote** mode will be activated once the **Local** mode is selected — the motor will run at the commanded speed.

EOI Operation

The **EOI** is the primary input/output device for the user. The **EOI** may be used to monitor system functions, input data into the system, or perform diagnostics.

Note: The Up/Down arrow keys and the Enter key may be used to perform the functions of the Rotary Encoder. The Rotary Encoder will be used in this explanation and throughout this manual for the Up, Down, and Enter key functions.

The software used with the HX7 ASD is menu driven; thus, making it a select and click environment. The operating parameters of a motor may be selected and viewed or changed using the **EOI**.

To change a parameter setting, go to the **Program** mode by pressing the **MON/PRG** key until the **Program** menu is displayed. Turn the **Rotary Encoder** until the desired parameter group is within the cursor block. Press the **Rotary Encoder** (repeat if there is a submenu).

The selection will take on the reverse video format (dark background/light text). Turn the **Rotary Encoder** to change the value of the parameter. Press the **ESC** key while the display is in the reverse video mode to exit the menu without saving the change or press the **Rotary Encoder** to accept the new setting.

Repeated **ESC** key entries takes the menu back one level each time the **ESC** key is pressed until the root level is reached. After reaching the root level, continued **ESC** entries will toggle the system to and from the **Frequency Command** screen and the **Panel** screen.

Note: Panel menu changes entered here will affect EOI-controlled ASD operation only.

System Operation

Operation (Local)



Read and understand all safety warnings before operating this equipment!

To run the motor perform the following steps:

1. Press the **MON/PROG** key until the **Frequency Command** screen is displayed (see [Figure 20 on pg. 37](#)).
2. Place the system in the **Local** mode (green **Local** LED illuminated) by pressing the **Local|Remote** key.
3. Ensure that there are no personnel around or near the motor or the motor-driven equipment.
4. Using the **Rotary Encoder** dial in a speed setting at the **Set** field and press the **Rotary Encoder**.
5. Press the **Run** key (illuminated green **RUN** LED turns red) and the motor accelerates to the set speed at the (default) programmed rate. The speed may be changed while running.
6. Press the **Stop|Reset** key to stop the motor.

Default Setting Changes

To change a parameter setting using the EOI, press the **MON/PRG** key until the **Program** menu is displayed.

From the **Program** menu scroll to the desired parameter group and press the **Rotary Encoder** — Repeat for sub-menu items. Once reaching the lowest level of a parameter group, scroll to the parameter to be changed and press the **Rotary Encoder**.

The parameter takes on the reverse video format (dark background/light text). Use the **Rotary Encoder** to scroll to the new value or setting. Press the **ESC** key to exit without saving the parameter change while still in the reverse video mode or press the **Rotary Encoder** to accept and save the change.

For a complete listing of the **Program** menu items, see the section titled [Program Mode on pg. 40](#). The menu items are mapped for convenience. The **Direct Access Numbers** are listed where applicable. The Direct Access numbers are also listed chronologically in the section titled [Direct Access Parameter Information on pg. 53](#).

The default settings may also be changed by entering the **Parameter Number** of the setting to be changed at the **Direct Access** menu (Program ⇒ Direct Access ⇒ *Applicable Parameter Number*). A listing of all parameters that have been changed from the default setting may be viewed sequentially by accessing the **Changed From Default** screen (Program ⇒ **Changed From Default**).

Note: Parameter **F012** was changed to create the example shown in [Figure 16](#).

Figure 16. Changed From Default screen.

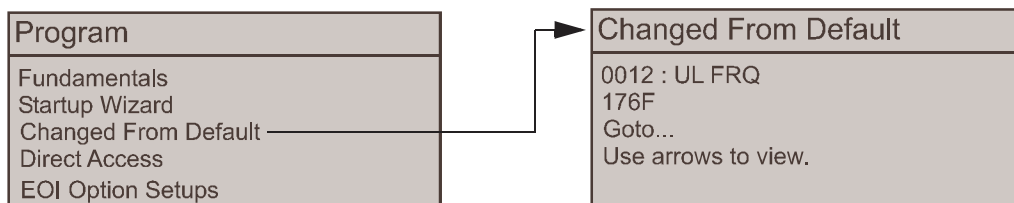

The **Changed From Default** feature allows the user to view (or change) the parameters that are different from the default or the post-reset settings. Once the **Changed From Default** screen is displayed, the system scrolls through all of the system parameters and halts once reaching a changed parameter.

The **Rotary Encoder** may be clicked once clockwise to continue scrolling forward or clicked once counterclockwise to begin scrolling in reverse. With each click of the **Rotary Encoder** from a stop, the system scrolls through the parameters and stops at the next parameter that has been changed.

Pressing the **Rotary Encoder** while a changed parameter is displayed accesses the settings of the changed parameter for viewing or changing.

Pressing **ESC** while the system is performing a **Changed From Default** search terminates the search. Pressing **ESC** when done searching (or halted at a changed parameter) returns the system to the **Program** menu.

Parameter settings may also be changed via **Communications**. See the *7-Series Serial Communications User Manual* (P/N 53840) for further information on using communications to change parameter settings. *The 7-Series Serial Communications Manual* may be acquired from the tic.toshiba.com/ind website at Drives ⇒ G7 LV Severe Duty Industrial ⇒ **Manuals** or from your Toshiba Sales Representative.

Startup Wizard Requirements

The **Startup Wizard** queries the user for information on the input and output signal parameters of the HX7 ASD. The HX7 ASD may also be setup by directly accessing each of the control parameters via the **Program** menu or the **Direct Access Numbers** (see the section titled [Direct Access Parameter Information on pg. 53](#)).

Upon initial system power up, the **Startup Wizard** starts automatically. The user is queried to either (1) run the **Startup Wizard (Run Now)**, (2) run the **Startup Wizard** at the next power up (**Run Next Time**), or (3) perform a manual setting of user-selected parameters (**Manually Configure**).

Select (2) **Run Next Time** to return to the **Program** menu without making any system changes.

Select (3) **Manually Configure** and the subsequent **Finish** box to return to the **Frequency Command** screen.

Select (1) (**Run Now**) to run the **Startup Wizard**. The user is queried for configuration data for the HX7 ASD using the following user-input screens.

Press **ESC** at any time to go back to the previous screen.

Motor Rating

Motors are designed and manufactured for a specific voltage and frequency range. The voltage and frequency specifications for a given motor may be found on the nameplate of the motor.

Wizard: Motor Rating

200V 50Hz

200V/230V 60Hz

Manually Configure. Finish.

Upper Limit Frequency

This parameter sets the highest frequency that the HX7 ASD will accept as a frequency command or frequency setpoint. The HX7 ASD may output frequencies higher than the **Upper Limit Frequency** (but, lower than the **Maximum Frequency**) when operating in the **PID Control** mode, **Torque Control** mode, or the **Vector Control** modes (sensorless or feedback).

Wizard: Upper Limit Frequency

What is your upper limit frequency?

60 Hz

Next

Finish.

Lower Limit Frequency

This parameter sets the lowest frequency that the HX7 ASD will accept as a frequency command or frequency setpoint. The HX7 ASD will output frequencies lower than the **Lower Limit Frequency** when accelerating to the lower limit or decelerating to a stop. Frequencies below the **Lower Limit** may be output when operating in the **PID Control** mode, **Torque Control** mode, or the **Vector Control** modes (sensorless or feedback).

Wizard: Min. Frequency

What is your lower limit frequency?

0.00 Hz

Next

Finish

Adjust Accel/Decel Automatically

When enabled, the HX7 ASD adjusts the acceleration and deceleration rates according to the applied load. The acceleration and deceleration times range from 12.5 to 800% of the programmed values for the active acceleration time [e.g., **Acceleration Time #1 (F009)** and **Deceleration Time #1 (F010)**].

The motor and the load must be connected prior to selecting **Automatic Accel/Decel**.

If **Automatic Accel/Decel** is not enabled, the **Acceleration** screen will appear followed by the **Deceleration** screen as shown below.

Wizard: Accel/Decel
Do you want the drive to adjust accel/decel times automatically?
<input type="button" value="Yes"/>
<input type="button" value="No"/>
<input type="button" value="Finish"/>

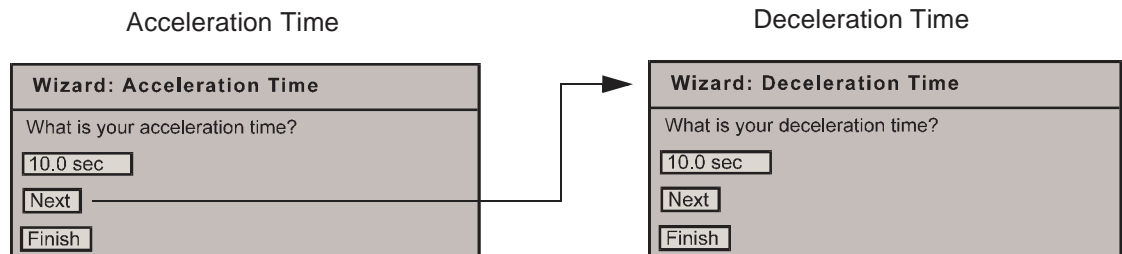

Volts per Hertz

This function establishes the relationship between the output frequency and the output voltage of the ASD.

Settings:

- Constant Torque
- Variable Torque
- Automatic Torque Boost
- Sensorless Vector Control (Speed)
- Automatic Torque Boost + Automatic Energy Savings
- Sensorless Vector Control (Speed) + Automatic Energy Savings
- V/f 5-point Setting (Opens 5-point Setting Screen)
- Sensorless Vector Control (Speed/Torque Switching)
- PG Feedback Vector Control (Speed/Torque Switching)
- PG Feedback Vector Control (Speed/Position Switching)

Wizard: Volts/Hertz
What type of volts/hertz control do you want?
<input type="button" value="Constant Torque"/>
<input type="button" value="Next"/>
<input type="button" value="Finish"/>

Motor Current Rating

This parameter allows the user to input the full-load amperage (FLA) of the motor. This value is used by the HX7 ASD to determine the **Thermal Overload** protection setting for the motor and may be found on the nameplate of the motor.

Wizard: Motor Current
What is the rated current of your motor?
<input type="text" value="5.00 A"/>
<input type="button" value="Next"/>
<input type="button" value="Finish"/>

Command Source

This selection allows the user to establish the source of the **Run** commands (e.g., **F**, **R**, **Stop**, etc.).

Settings:

- Use Control Terminal Strip
- Use LED Keypad Option
- Use Common Serial (TTL)
- Use RS232/RS485
- Use Communication Card

Wizard: Command Source
Where will your run/stop and other commands come from? <input type="button" value="Use terminal block"/>
<input type="button" value="Next"/>
<input type="button" value="Finish"/>

Frequency Reference Source

This selection allows the user to establish the source of the **Frequency** (speed) command.

Settings:

- Use VI/II
- Use RR
- Use RX
- Use Option Card RX2
- Use LED Keypad Option
- Use Binary/BCD Input
- Use Common Serial (TTL)
- Use RS232/RS485
- Use Communication Card
- Use Motorized Pot Simulation
- Use Pulse Input Option

Wizard: Frequency Source
Where will your frequency reference come from? <input type="button" value="Use RR"/>
<input type="button" value="Next"/>

Wizard: Finish

This screen is the final screen of the **Startup Wizard**. The basic parameters of the HX7 ASD have been set. Click **Finish** to return to the **Program** mode. Additional application-specific programming may be required.

Wizard: Finished
Wizard is done. Other parameters may need adjustment for proper operation. Always read instruction manual to ensure proper setup.
<input type="button" value="Finish"/>

Command Mode and Frequency Mode Control

Command control includes instructions such as **Stop, Run, Jog**, etc. The source of the **Command** signal must be established for normal operation.

Frequency commands control the output speed of the ASD. The source of the frequency (speed) control signal must be established for normal operation.

The source of the command control and speed control may be either internal or external. Once the source signal is selected for either function, the system may be configured to use the selected signal all of the time or switch to another source under user-defined conditions.

Command and **Frequency** control may be carried out using any one of several control methods (signal sources) or combinations thereof. In the event that simultaneous control commands are received from the various sources, the signal sources are assigned priority levels and proper system operation is maintained. The primary control method for **Command** and **Frequency** control uses the settings of **F003** and **F004**, respectively.

Command Control (F003)

The **Command Mode** selection of **F003** establishes the primary source of the command input for the ASD. However, the **Override** feature may supersede the **F003** setting as indicated in [Table 3 on page 27](#).

[Table 3](#) shows the hierarchy of the control sources managed by the **Override** function. The level of the control item on the hierarchy is listed from left to right, highest to lowest, respectively. As indicated in the table, the **Override** setting may supersede the **F003** setting.

Placing the EOI in the **Local** mode selects either the **RS232/RS485** or the **Common Serial (TTL)** as the **Command Mode** control source. Once in the **Local** mode, the **LCD Port Connection** setting determines if the **RS232/RS485** or if the **Common Serial (TTL)** will be used for **Command** control. **Local** mode operation may be superseded by commands received via **Communications**.

In addition, the remaining control sources may be placed into the override mode using **Communications**.

The source of the **Command** control signal may be selected by:

- The **F003** setting,
- Placing an item from the list below in the **Override** mode via communications, or
- Placing the EOI in the **Local** mode (places only the RS232/RS485 or the Common Serial [TTL] in the Override mode).

Possible **Command** signal source selections include the following:

- Control Terminal Strip (default),
- LED Keypad Option,
- Common Serial (TTL),
- RS232/RS485,
- Communication Card, or the

Standard Mode Settings
Command Mode: Use Control Terminal Strip
Frequency Mode #1: Use RR
Frequency Mode #2:

- **F003** setting (is used if no signal sources are in the Override mode).

Note: The **Control Terminal Strip** is placed in the **Override** mode by assigning a discrete terminal to **Command Control Terminal Strip Priority (54)** and connecting the terminal to **CC**. Once activated (Run command required), the **Control Terminal Strip** settings will be used for **Override Command** control (F, R, Preset Speeds, etc.).

Frequency Control (F004)

The **Frequency Mode #1** (or the **Frequency Mode #2**) setting establishes the user-selected source of the frequency-control input for the ASD. The signal source selected here is used for speed control unless the **Reference Priority Selection** parameter is configured to automatically switch this setting (see **F200**) or if the **Override** feature is enabled (via communications or via the Local mode operation).

Standard Mode Settings
Frequency Mode #1:
Use RR
Frequency Mode #2:
Use VI/II
Reference Priority Selection:

[Table 3 on page 27](#) shows the hierarchy of the frequency control sources managed by the **Override** function. The level of the control item on the hierarchy is listed from left to right, highest to lowest, respectively. As indicated in the table, the **Override** setting may supersede the selection at **F004**.

Placing the EOI in the **Local** mode selects either the **RS232/RS485** or the **Common Serial (TTL)** as the **Frequency Mode #1** control source. Once in the **Local** mode, the **LCD Port Connection** setting determines if the **RS232/RS485** or the **Common Serial (TTL)** will be used for **Frequency Mode #1** control. **Local** mode operation may be superseded by frequency commands received via **Communications**.

Example: With the EOI set to **Local** and the **LCD Port Connection** set to **Common Serial (TTL)**, setting the **Communication Card** or **RS232/RS485** control to **Override** will supersede the **Common Serial (TTL)** setting.

The remaining control sources may be placed into the override mode using communications.

The source of the **Frequency** control signal may be selected by:

- The **F004** setting,
- Placing an item from the list below in the **Override** mode via communications, or
- Placing the EOI in the **Local** mode (places only the RS232/RS485 or Common Serial in the Override mode).

Possible **Frequency** control source selections include the following:

- Communication Card,
- RS232/RS485,
- Common Serial (TTL),
- LED Keypad,
- Control Terminal Strip (default setting), or
- **F004** setting (used if no other items are in the Override mode).

Note: The **Control Terminal Strip** is placed in the **Override** mode by assigning a discrete terminal to **VI/II Terminal Priority** and connecting the terminal to **CC**. Once the discrete terminal is activated, **VI/II** is used as the **Control Terminal Strip Override** control item.

Command and Frequency Control Selections

The user may select only one **Command** source and only one source for **Frequency** control. The default settings for **Command** and **Frequency** control are **Use Control Terminal Strip** and **Use RR**, respectively.

The HX7 ASD has a command register for each item listed as a **Command** or **Frequency** source. The registers store the **Override** setting for each control source. The registers are continuously scanned to determine if any of the listed items are in the **Override** mode.

For each scan cycle, the command registers of the control sources are scanned for the **Override** setting in the order that they are listed in [Table 3](#). The first item of the **Command** section and the first item of the **Frequency** section detected as being in the **Override** mode will be used for **Command** and **Frequency** control, respectively. If no items are detected as being in the **Override** mode, the settings of **F003** and **F004** will be used for **Command** and **Frequency** control, respectively.

Any or all of the **Command** and **Frequency** control input sources may be placed in the **Override** mode.

Placing the HX7 ASD in the **Local** mode (Local/Remote LED on) via the EOI places the **RS232/RS485** or the **Common Serial (TTL)** control selections in the **Override** mode for **Command** and **Frequency** input (see the section titled [Override Operation](#) below for the proper setting). The **Local/Remote** control **Override** feature for **Command** and **Frequency** (or either) may be enabled/disabled at Program ⇒ EOI Option Setups ⇒ **Local-Remote Key** (enabled with check in box).

Communications may be used to place the remaining **Command** and eligible **Frequency** control input sources in the **Override** mode. Once placed in the **Override** mode this setting is valid until it is cancelled, the power supply is turned off, or the unit is reset.

Override Operation

The command registers of the listed signal sources are scanned in the order that they are listed in [Table 3](#) to determine which input sources are in the **Override** mode. During each register scan cycle, the first item detected as having the **Override** function turned on is the selection that is used for **Command** or **Frequency** control input.

The **Override** control setting supersedes the setting of the **Command** mode setting (**F003**) and the **Frequency** mode setting (**F004**). However, the **F003** and **F004** settings will be used in the event that the register scan returns the condition that none of the listed items have the **Override** feature turned on (see [Table 3](#)).

Command and Frequency-Control Override Hierarchy

[Table 3](#) lists the input conditions and the resulting output control source selections for Command and Frequency control Override operation. The HX7 ASD reads the command registers of the listed control items from the left to the right. In the table the number 1 indicates that the Override feature is turned on for that control input source; X = Don't are; and 0 = Override Off.

The first item to be read that has the Override feature turned on will be used for Command or Frequency control.

Table 3. Command and Frequency control hierarchy.

1	2	3	4	5	6	Priority Level
Communication Card	RS232/RS485	Common Serial	Panel (LED Keypad)	Control Terminal (Binary/BCD Input)	F003/F004	Command/Frequency Mode
1	X	X	X	X	X	Communication Card
0	1	X	X	X	X	RS232/RS485
0	0	1	X	X	X	Common Serial
0	0	0	1	X	X	Panel (LED Keypad)
0	0	0	0	1	X	Control Terminal
0	0	0	0	0	F003/F004 Setting	F003/F004 Setting

Command Control Selections

The following is a listing and description of the **Command Mode (F003)** selections (Program ⇒ Fundamental Parameters ⇒ Standard Mode Selection ⇒ **Command Mode**).

Settings:

Use Control Terminal Strip

Allows for **Command** control input via the 25-pin terminal strip on the **Control Terminal Strip** PCB.

Use LED Keypad Option

The **LED Keypad** is unavailable at the time of this release.

Use Common (TTL)

Set the **LCD Port Connection** to **Common Serial (TTL)** to use this feature.

Use RS232/RS485

Set the **LCD Port Connection** to **RS232/RS485** to use this feature.

Use Communication Card

Routes the control and monitoring I/O to CNU3 of the **Control Board** of the HX7 ASD (Communication Card connector).

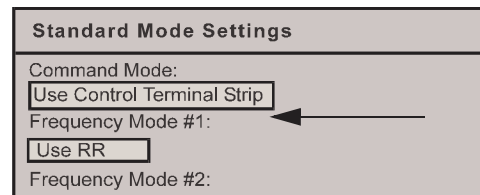

Frequency Control Selections

The following is a listing and description of the **Frequency Mode (F003)** selections (Program ⇒ Fundamental Parameters ⇒ Standard Mode Selection ⇒ **Frequency Mode #1**).

Settings:

Use VI/II

0 to 10-volt DC analog input connected to **VI** or a 4 – 20 mA (or 0 to 1 mA) DC current connected to **II** (cannot use both simultaneously).

Use RR

0 to 10-volt DC analog input connected to **RR**.

Use RX

-10 to +10-volt DC analog input connected to **RX**.

Use Option Card RX2

-10 to +10-volt DC analog input connected to **RX2**.

Use LED Keypad Option

The LED Keypad is unavailable at the time of this release.

Use Binary/BCD Input

Allows for discrete terminal input to control the ASD output.

Use Common Serial (TTL)

To use the EOI for control requires that the **LCD Port Connection** be set to **Common Serial (TTL)** to use this feature.

Use RS232/RS485

To use the EOI for control requires that the **LCD Port Connection** be set to **RS232/RS485** to use this feature.

Use Communication Card

Routes the control and monitoring I/O to CNU3 of the **Control Board** of the HX7 ASD (Option Card connector).

Use Motorized Pot Simulation

A discrete terminal may be configured to increase or decrease the speed of the motor by momentarily connecting the assigned terminal to **CC**. See [Table 6 on page 170](#) for further information on this feature.

Use Pulse Input Option

Configures the system to receive pulse input. See [PG Speed Reference #1 on pg. 97](#) for further information on this feature.

Standard Mode Settings	
Command Mode:	<input type="text" value="Use Control Terminal Strip"/>
Frequency Mode #1:	<input type="text" value="Use RR"/> ←
Frequency Mode #2:	<input type="text"/>

System Configuration and Menu Options

Root Menus

The **MON/PRG** key is used to access the three root menus of the HX7 ASD: the **Frequency Command** screen, the **Monitor** screen, and the **Program** screen. From either mode, press the **MON/PRG** key to loop through to the other modes (see [Figure 17](#)).

In the event of a fault, the HX7 ASD displays the fault screen and provides an on-screen indication of the fault type. The **Fault** screen remains in the **MON/PRG** screen rotation (see [Figure 17](#)) until the source of the fault is removed and the ASD is reset.

Figure 17. Root Menu Mapping.

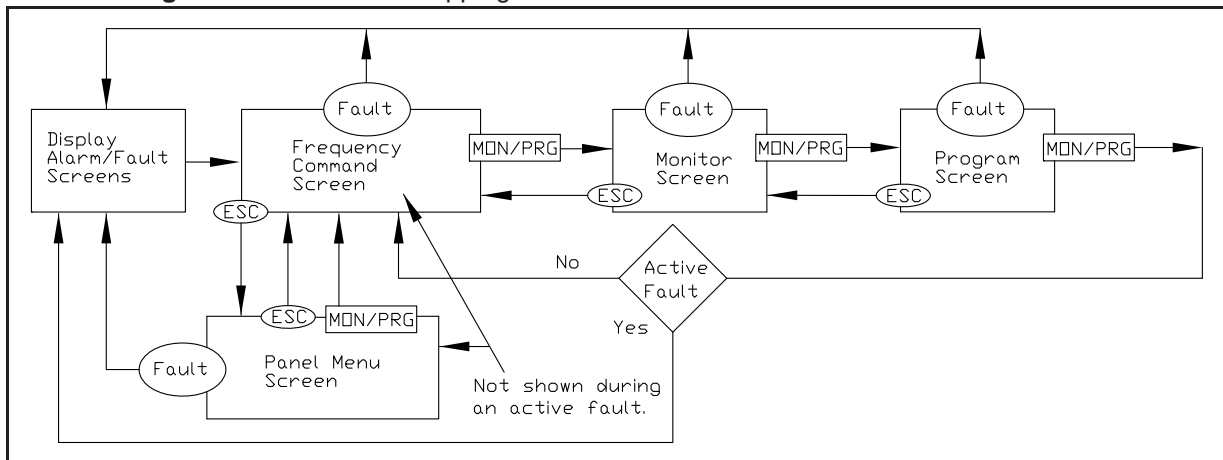

Frequency Command Screen

Frequency Setting

While operating in the **Local** mode (**Local** LED is illuminated on the EOI), the running frequency of the motor may be set from the **Frequency Command** screen. Using the **Rotary Encoder**, enter the desired **Frequency Command** value, press the **Enter** key and then press the **Run** key. The motor will run at the **Frequency Command** speed and may be changed while running. The **Frequency Command** screen is not displayed during an active trip.

Figure 18. Frequency Command Screen.

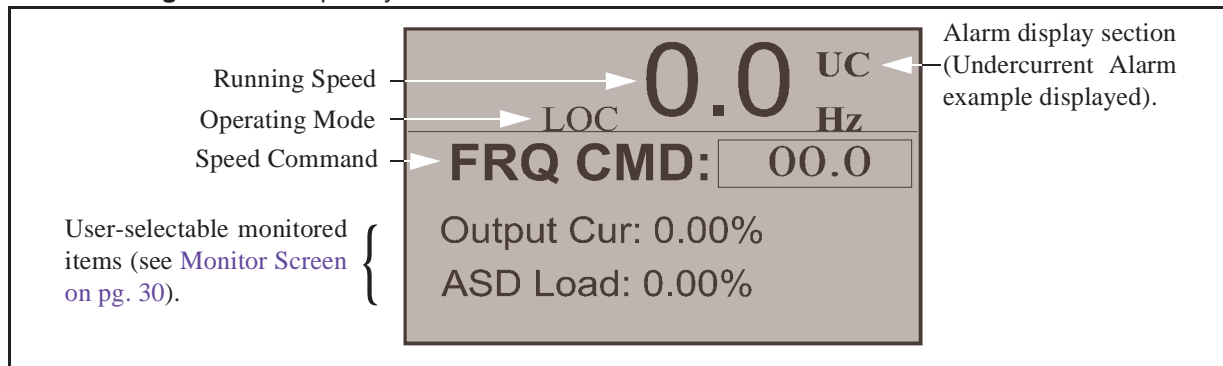

The **Panel Menu** screen provides easy-access to the most common setup parameters. **Panel Menu** changes will affect EOI-controlled ASD operation only and is accessed by pressing the **ESC** key from the **Frequency Command** screen.

Monitor Screen

The **Monitor** screen reports the status of motor performance variables, control settings, and configuration data during motor operation. The monitored items are listed and described below.

The items listed may be selected and displayed at the **Frequency Command** screen while the ASD is running. See Program ⇒ System Information and Setup ⇒ **Scrolling Monitor** to select the monitored items to be displayed.

Note: The **Monitor** screen lists the read-only running status and the at-trip status of the listed parameters.

Run Frequency — If tripped, this field records the at-trip frequency. Otherwise, the current output frequency is displayed.

Frequency Reference — Displays the current frequency command.

Output Current — Shows the instantaneous output current as a percentage of the rating of the ASD or as a current.

Bus Voltage — Shows the instantaneous DC bus voltage as a percentage of the rating of the ASD or as a voltage.

Output Voltage — Shows the instantaneous output voltage as a percentage of the rating of the ASD or as a voltage.

Input Terminals — Shows the status of the discrete input terminals.

Output Terminals — Shows the status of the discrete output terminals.

Timer — Displays the accumulated run-time since the last reset or power up of the ASD.

Post Compensation Frequency — Displays the output frequency of the ASD after the application of the waveform adjustment compensation for changes in the input voltage.

Feedback Instantaneous — Displays the instantaneous PID feedback value.

Feedback 1-Second — Displays the filtered PID feedback value.

Torque — Displays the torque output.

Torque Reference — Displays the commanded torque.

Torque Current — Displays the torque current.

Excitation Current — Displays the excitation current.

PID Value — Displays the instantaneous PID feedback value.

Motor Overload — Displays the relationship of time to the magnitude of the motor overload as a ratio. A higher overload means a shorter run-time in this condition.

ASD Overload — Displays the relationship of time to the magnitude of the ASD overload as a ratio. A higher overload means a shorter run-time in this condition.

DBR Overload (Not used) — Displays the relationship of time to the magnitude of the DBR overload as a ratio. A higher overload means a shorter run-time in this condition.

Motor Load — Shows the instantaneous motor load requirements.

ASD Load — Shows the instantaneous load placed on the ASD.

DBR Load (Not used) — Shows the instantaneous load placed on the DBR.

Input Power — Shows the instantaneous input power level to the ASD.

Output Power — Shows the instantaneous output power level of the ASD.

Peak Current — Shows the highest current level achieved since the last startup or reset. This value is displayed as a percentage of the full rating of the ASD or as an amperage.

Peak Voltage — Shows the highest voltage level achieved since the last startup or reset. This value is displayed as a percentage of the full rating of the ASD or as an amperage.

PG Speed — Shows the instantaneous speed as detected by the shaft-mounted encoder.

Direction — Shows the direction of the motor rotation.

PG Position — Shows the instantaneous PG position as detected by the shaft-mounted encoder.

RR — Displays the RR input as a percentage of its full range.

***VI/II** — Displays the VI/II input as a percentage of the full range of the VI/II value.

*Note: The VI/II input represents two analog inputs. The **VI** input is used for a 0 – 10 VDC analog signal and the **II** input is used for current loop applications, such as with a 4-20 mA signal. Either may be used as a frequency or torque command source; however, the two cannot function simultaneously.*

RX — Displays the RX input as a percentage of its full range.

RX2 — Displays the RX2 input as a percentage of its full range.

FM — Displays the FM output as a percentage of its full range.

AM — Displays the AM output as a percentage of its full range.

Option Type — TBD.

Option Terminal A — TBD.

Option Terminal B — TBD.

Option Terminal O — TBD.

Option Terminal P — TBD.

Maximum Output — TBD.

Direction — Displays the ASD Forward/Reverse status (not available at the Scrolling Monitor).

Program Mode

Table 4 lists the menu items of the **Program** mode and maps the flow of the menu selections. The **Parameter Numbers** for the listed functions are provided where applicable. The functions listed may be accessed (and changed) as mapped below or via the **Direct Access** method: Program ⇒ Direct Access ⇒ *Applicable Parameter Number*.

Table 4. Program mode mapping.

Program Menu Navigation			
Primary Menu	Sub Menu	Parameter Name	Parameter Number
FUNDAMENTALS	Frequency Setting	Maximum Frequency	F011
		Upper Limit	F012
		Lower Limit	F013
		V/f Pattern	F015
	Standard Mode Selection	Command Mode	F001
		Frequency Mode #1	F004
		Frequency Mode #2	F207
		Reference Priority Selection	F200
	Accel/Decel #1 Settings	Mode #1/#2 Switching Frequency	F208
		Accel #1	F009
		Decel #1	F010
		Accel/Decel Pattern	F502
	Motor Set #1	Automatic Accel/Decel Enable/Disable	F000
		#1 Base Frequency	F014
		#1 Max Output Voltage	F306
		#1 Torque Boost	F016
		#1 Electronic Thermal Protection Level	F600
STARTUP WIZARD	(See the section titled Startup Wizard Requirements on pg. 39.)		N/A
CHANGED FROM DEFAULT	(See the section titled Default Setting Changes on pg. 38.)		
DIRECT ACCESS	(See the section titled Direct Access Parameter Information on pg. 53.)		
EOI OPTION SETUPS	Contrast (adjustment)	Darker (highlight Darker and press Enter)	N/A
		Lighter (highlight Lighter and press Enter)	
	Local/Remote Key	Command	
		Frequency	
	Realtime Clock Setup	Date and Time Setting	
	Preferences	Double Click Speed	
		Arrow Speed	
		Encoder Speed	
	Alarm Popups	Encoder Action	
		Overheat Alarm	
	Undervoltage Alarm		

Program Menu Navigation			
Primary Menu	Sub Menu	Parameter Name	Parameter Number
EOI OPTION SETUPS	Alarm Popups	Over-current Alarm	N/A
		ASD Overload Alarm	
		Motor Overload Alarm	
		Timer	
		Overtorque Alarm	
		DBR Resistor Alarm (Not used)	
	Lockout	Lockout Reset	N/A
		Lockout Monitor	
		Lockout Run/Stop	
		Lockout Parameter Access	
		Lockout Parameter Write	
		Lockout Frequency Change	
		Lockout Options	
		Lockout Local/Remote	
Password (Enable/Enter)			
Review Startup Screen	Displays the Startup screen — ESC to clear		
UTILITY PARAMETERS	Versions (read only)	Typeform	N/A
		CPU Version	
		CPU Revision	
		EEPROM #1 Version	
		EEPROM #2 Version	
		EOI Version	
	Display Units	User-defined Units Enable/Disable	N/A
		User-defined Units	
		Hz Per User-defined Unit	F702
		Frequency Display Resolution	F703
		Units for Voltage and Current	F701
	Type Reset	None	F007
		Auto Setup for 50 Hz	
		Auto Setup for 60 Hz	
		Restore Factory Defaults	
		Clear Trip	
		Clear Run Timer	
New Base Drive Board			
Save User Parameters			
Restore User Parameters			
Reload EOI Flash			
Reset EOI Memory			

Program Menu Navigation			
Primary Menu	Sub Menu	Parameter Name	Parameter Number
TERMINAL SELECTION PARAMETERS	Input Terminal Function	F	F111
		R	F112
		ST	F113
		RES	F114
		S1	F115
		S2	F116
		S3	F117
		S4	F118
		S5	F119
		S6	F120
		S7	F121
		12	F122
		13	F123
		14	F124
		15	F125
		16	F126
		ON	F110
	Output Terminal Functions	Out 1	F130
		Out 2	F131
		FL	F132
		4	F133
		5	F134
		6	F135
		7	F136
	Analog Input Functions	Acc/Dec Base Frequency Adjustment	F650
		Upper-limit Frequency Adjustment	F651
		Acceleration Time Adjustment	F652
		Deceleration Time Adjustment	F653
		Torque Boost Adjustment	F654
	Reach Settings	Low Speed Signal Output Frequency	F100
		Speed Reach Setting Frequency	F101
		Speed Reach Setting Frequency Range	F102
	FP Terminal Settings	FP Terminal Meter Selection	F676
		FP Terminal Meter Adjustment	F677
	Input Special Functions	ST Signal Selection	F103
		F/R Priority Selection (w/both on)	F105
		Input Terminal Priority	F106
		Extended Terminal Function	F107
	Line Power Switching	(Commercial Power Switching) On Trip Enable/Disable	F354

Program Menu Navigation			
Primary Menu	Sub Menu	Parameter Name	Parameter Number
TERMINAL SELECTION PARAMETERS	Line Power Switching	Switching-Frequency Enable/Disable and Setting	F355
		ASD-Output Switching Wait-Time	F356
		Commercial Input-Power Wait-Time	F357
		Commercial-Power Switching-Frequency Hold-Time	F358
	Input Terminal Delays	F	F140
		R	F141
		ST	F142
		RES	F143
		S1-S4	F144
		S5-S16	F145
	Output Terminal Delays	Out1 On Delay	F150
		Out1 Off Delay	F160
		Out2 On Delay	F151
		Out2 Off Delay	F161
		FL On Delay	F152
		FL Off Delay	F162
		Out4 On Delay	F153
		Out4 Off Delay	F163
		Out5 On Delay	F154
		Out5 Off Delay	F164
Out6 On Delay		F155	
Out6 Off Delay		F165	
Out7 On Delay		F156	
Out7 Off Delay	F151		
FREQUENCY SETTING PARAMETERS	Analog Filter	Analog Input Filter Selection	F209
	Speed Reference Setpoint	VI/II	F201
		RR	F210
		RX	F216
		RX2	F222
		BIN	F228
		PG	F234
	Jog Settings	Jog Run Frequency	F260
		Jog Stop Control	F261
		Jog Window Enable/Disable	N/A
	Preset Speeds	#1 Frequency & Characteristics	F018
		#2 Frequency & Characteristics	F019
		#3 Frequency & Characteristics	F020
		#4 Frequency & Characteristics	F021

Program Menu Navigation			
Primary Menu	Sub Menu	Parameter Name	Parameter Number
FREQUENCY SETTING PARAMETERS	Preset Speeds	#5 Frequency & Characteristics	F022
		#6 Frequency & Characteristics	F023
		#7 Frequency & Characteristics	F024
		#8 Frequency & Characteristics	F287
		#9 Frequency & Characteristics	F288
		#10 Frequency & Characteristics	F289
		#11 Frequency & Characteristics	F290
		#12 Frequency & Characteristics	F291
		#13 Frequency & Characteristics	F292
		#14 Frequency & Characteristics	F293
	#15 Frequency & Characteristics	F294	
	Preset Speed Mode	Use Preset Speed Mode Enable/Disable	F380
	Fwd/Rev Disable	Disable Forward Run/Disable Reverse Run	F311
	Motorized Pot Settings	Motorized Pot Setting Disposition at Power Down	F108
		Minimum Frequency	N/A
Maximum Frequency		N/A	
PROTECTION PARAMETERS	Dynamic Braking (Not used with this system)	Dynamic Braking Enable/Disable	F304
		Dynamic Braking Resistance Capacity	F309
		Dynamic Braking Resistance	F308
	Stall	Over-current Stall Level	F601
		Over-voltage Stall Enable/Disable	F305
		Over-voltage Stall Level	F626
		Over-voltage Stall Level (Fast)	F625
		Continuing Stall Period (During Positive Torque/Speed)	F452
		Stall Prevention During Regeneration	F454
	DC (Injection) Braking	DC Injection Start Frequency	F250
		DC Injection Braking Current	F251
		DC Injection Braking Time	F252
		Motor Shaft Fixing Control	F253
		Motor Shaft Stationary Control Enable/Disable	F254
	Emergency Off Settings	Emergency Off Mode Setting	F603
		DC Injection Braking Time	F604
		Emergency Off Activation of the FL Output Enable/Disable	N/A
	Retry/Restart Configuration	Number of Retries	F303
		Restart Conditions	F301
		Scan Rate	F312
		Lock-on Rate	F313

Program Menu Navigation			
Primary Menu	Sub Menu	Parameter Name	Parameter Number
PROTECTION PARAMETERS	Retry/Restart Configuration	Search Method	F314
		Search Inertia	F315
	Undervoltage/Ridethrough	Ridethrough Mode	F302
		Ridethrough Time	F310
		Undervoltage Stall Level	F629
		Undervoltage Trip Enable/Disable	F627
		Undervoltage Detection Time	F628
		Overload	OL Reduction Starting Frequency
	Motor 150% OL Time Limit		F607
	Soft Stall Enable/Disable		F017
	Motor Overload Trip Enable/Disable		N/A
	V/f Motor Enable/Disable		N/A
	Trip Settings	Trip Save at Power Down Enable/Disable	F602
	Cooling Fan Control	Cooling Fan Control Mode	F620
	Cumulative Run Timer	Cumulative Run Timer Alarm Setting	F621
	Phase Loss	Output Phase Loss Detection Enable/Disable	F605
	Low Current Settings	Low Current Trip/Alarm Configuration	F610
	Abnormal Speed Settings	Abnormal Speed Detection Filter Time	F622
		Overspeed Detection Frequency Range	F623
		Speed Drop Detection Frequency Range	F624
	Short Circuit Detect Pulse	Short-Circuit-Pulse Run Command	F613
		Short-Circuit-Pulse Run Duration	F614
	Overtorque Settings	Overtorque Trip Enable/Disable	F615
		Overtorque Trip/Alarm Level During Power Operation	F616
		Overtorque Trip/Alarm Level During Regeneration	F617
		Overtorque Detection Time	F618
	Brake Fault Timer	Braking Trouble Internal Timer	F630
		Release After Run Timer	F632
	Base Frequency Voltage	Supply Voltage Compensation Enable/Disable	F307
		Output Voltage Limitation Enable/Disable	
	Soft Start	Suppression of Inrush-Current Timing	F608
		Interlock with ST	F609
TORQUE SETTING PARAMETERS	Set Points	VI/II	F205
		RR	F214
		RX	F220
		RX2	F226
		BIN	F232

Program Menu Navigation				
Primary Menu	Sub Menu	Parameter Name	Parameter Number	
TORQUE SETTING PARAMETERS	Torque Control	Torque Command Selection	F420	
		Torque Command Filter	F421	
		Synchronized Torque Bias Input Selection	F422	
		Tension Torque Bias Input Selection	F423	
		Load Sharing Gain Input Selection	F424	
	Torque Limit Settings	Positive Torque Limit #1 Selection	F440	
		Negative Torque Limit #1 Selection	F442	
		Manual Settings	F441	
		Torque Limit Mode	F450	
		Torque Limit Mode (speed dependent)	F451	
	Manual Torque Limit Settings	#1 Positive/Negative Torque Limit Settings	F441	
		#2 Positive/Negative Torque Limit Settings	F444	
		#3 Positive/Negative Torque Limit Settings	F446	
		#4 Positive/Negative Torque Limit Settings	F448	
	Torque Speed Limiting	Torque Command Mode Selection	F429	
		Forward Speed Limit Selection	F425	
		Forward Speed Limit Level	F426	
		Reverse Speed Limit Selection	F427	
		Reverse Speed Limit Level	F428	
		Speed Limit Torque Reference Selection	F430	
		Speed Limit Torque Level	F431	
		Speed Limit Torque Band	F432	
		Speed Limit Torque Recovery Time	F433	
	FEEDBACK PARAMETERS	Feedback Settings	Input Selection	F360
			Proportional (P) Gain	F362
			Integral (I) Gain	F363
			Differential (D) Gain	F366
			Delay Filter	F361
Deviation Limits — Upper/Lower			F364	
Position Difference Limit			F631	
PG Settings		Number of PG Input Pulses	F367	
		PG Input Phases	F368	
		PG Disconnection Detection Selection	F369	
		Electronic Gear Setting	F370	
		Position Loop Gain	F371	
		Positioning Completion Range	F372	
		Frequency Limit at Position	F373	
		Current Control Proportional Gain	F374	
Current Control Integral Gain	F375			

Program Menu Navigation			
Primary Menu	Sub Menu	Parameter Name	Parameter Number
FEEDBACK PARAMETERS	PG Settings	Speed Loop Proportional Gain	F376
		Speed Loop Integral Gain	F377
		Motor Counter Data Selection	F378
		Speed Loop Parameter Ratio	F379
	Drooping Control	Drooping Gain 100%	F320
		Speed at Drooping Gain 0%	F321
		Speed at Drooping Gain 100%	F322
		Drooping Insensitive Torque Band	F323
		Drooping Output Filter	F324
		Drooping Reference	F327
		Load Inertia (Acc/Dec Torque)	F325
		Load Torque Filter	F326
	Override Control	Adding Input Selection	F660
		Multiplying Input Selection	F661
		LED Option Override Multiplication Gain	F729
PATTERN RUN CONTROL PARAMETERS	Pattern Run	Pattern Run Mode Enable/Disable and Restart Configuration	F520
	Speeds	Pattern #1 Speeds	F530
		Pattern #2 Speeds	F540
		Pattern #3 Speeds	F550
		Pattern #4 Speeds	F560
	Preset Speeds	#1 Frequency & Characteristics	F018
		#2 Frequency & Characteristics	F019
		#3 Frequency & Characteristics	F020
		#4 Frequency & Characteristics	F021
		#5 Frequency & Characteristics	F022
		#6 Frequency & Characteristics	F023
		#7 Frequency & Characteristics	F024
		#8 Frequency & Characteristics	F287
		#9 Frequency & Characteristics	F288
		#10 Frequency & Characteristics	F289
		#11 Frequency & Characteristics	F290
#12 Frequency & Characteristics	F291		
#13 Frequency & Characteristics	F292		
#14 Frequency & Characteristics	F293		
#15 Frequency & Characteristics	F294		
Preset Speed Mode	Use Preset Speed Enable/Disable	F380	
COMMUNICATION SETTING PARAMETERS	Communication Settings	ASD Number	F802

Program Menu Navigation			
Primary Menu	Sub Menu	Parameter Name	Parameter Number
COMMUNICATION SETTING PARAMETERS	Communication Settings	TTL Baud Rate	F800
		RS232/RS485 Baud Rate	F820
		Parity	F801
		RS232/RS485 Communication Time Out Time	F803
		TTL Communication Time Out Action	F804
		RS232/RS485 Communication Time Out Action	N/A
		TTL Communication Interval	F805
		RS232/RS485 Wire Count	F821
		RS232/RS485 Response Time	F825
		TTL Master Output Selection	F806
		RS232/RS485 Master Output Selection	F826
		LCD Port Connection	N/A
	Communication Reference Adjust	Communication Frequency Point Selection	F810
	S20 Settings	Receive Address	F860
		Transmit Address	F861
		Speed Reference Station	F862
		Speed Reference Address	F863
		Torque Reference Station	F865
		Torque Reference Address	F866
		Fault Detect Station Number	F868
		Station Mode	F869
		S20 Reset	F899
		Error Mode	F850
	Error Detect Time	F851	
	Scan Receive Settings	#1 Scan Receive	F831
		#2 Scan Receive	F832
		#3 Scan Receive	F833
		#4 Scan Receive	F834
		#5 Scan Receive	F835
		#6 Scan Receive	F836
	Scan Transmit Settings	#1 Scan Transmit	F841
		#2 Scan Transmit	F842
		#3 Scan Transmit	F843
		#4 Scan Transmit	F844
		#5 Scan Transmit	F845
		#6 Scan Transmit	F846
	Communication Error	Command Request Disposition on Error	F830

Program Menu Navigation			
Primary Menu	Sub Menu	Parameter Name	Parameter Number
COMMUNICATION SETTING PARAMETERS	Optional Parameters	Optional Parameter #1	F890
		Optional Parameter #2	F891
		Optional Parameter #3	F892
		Optional Parameter #4	F893
		Optional Parameter #5	F894
METER TERMINAL ADJUSTMENT PARAMETERS	FM	FM Terminal Assignment	F005
		FM Terminal Adjustment	F006
	AM	AM Terminal Assignment	F670
		AM Terminal Adjustment	F671
	Analog1	Analog 1 Terminal Assignment	F672
		Analog 1 Terminal Adjustment	F673
	Analog2	Analog 2 Terminal Assignment	F674
		Analog 2 Terminal Adjustment	F675
MOTOR PARAMETERS	Vector Motor Model	AutoTune Enable/Disable and Reset Config.	F400
		AutoTune Enable/Disable of Motor Constant 3	F414
		Slip Frequency Gain	F401
		Motor Constant 1 (primary resistance)	F402
		Motor Constant 2 (secondary resistance)	F403
		Motor Constant 3 (exciting inductance)	F404
		Motor Constant 4 (load inertia)	F405
		Motor Constant 5 (leakage inductance)	F410
	Motor Settings	Number of Motor Poles	F411
		Motor Capacity (kW)	F412
		Motor Type	F413
	Motor Set #1	#1 Base Frequency	F014
		#1 Max Output Voltage	F306
		#1 Torque Boost	F016
		#1 Electronic Thermal Protection Level	F600
	Motor Set #2	#2 Base Frequency	F170
		#2 Max Output Voltage	F171
		#2 Torque Boost	F172
		#2 Electronic Thermal Protection Level	F173
	Motor Set #3	#3 Base Frequency	F174
		#3 Max Output Voltage	F175
		#3 Torque Boost	F176
		#3 Electronic Thermal Protection Level	F177
	Motor Set #4	#4 Base Frequency	F178
		#4 Max Output Voltage	F179
		#4 Torque Boost	F180
		#4 Electronic Thermal Protection Level	F181

Program Menu Navigation			
Primary Menu	Sub Menu	Parameter Name	Parameter Number
MONITOR SETUP	Trip History	Trip History Records	N/A
	Trip Monitor From ASD	Most Recent	N/A
		Second Most Recent	N/A
		Third Most Recent	N/A
		Fourth Most Recent	N/A
Scrolling Monitor Select	Scrolling Monitor Configuration Selection	N/A	
SPECIAL CONTROL PARAMETERS	Frequency Control	Start Frequency	F240
		End Frequency	F243
		Run Frequency	F241
		Run Frequency Hysteresis	F242
	Jump Frequencies	Jump Frequency Bandwidth Settings	F271
		Jump Frequency Processing Selection	F276
	Carrier Frequency	PWM Carrier Frequency Setting	F300
	Accel/Decel #1 – #4 Settings	Accel/Decel/Pattern #1 Configuration	F009
		Accel/Decel/Pattern #2 Configuration	F500
		Accel/Decel/Pattern #3 Configuration	F510
		Accel/Decel/Pattern #4 Configuration	F514
	Accel/Decel Special	S-Pattern Lower Limit Adjustment	F506
		S-Pattern Upper Limit Adjustment	F507
		Accel/Decel Time Lower Limit	F508
		Accel/Decel Switching Frequency #1	F505
		Accel/Decel Switching Frequency #2	F513
		Accel/Decel Switching Frequency #3	F517
		Accel/Decel Display Resolution	F704
	Crane/Hoist Load	High-Speed Operation at Light Load	F330
		Light-load High-speed Operation Switching Lower Limit Frequency	F331
		Light-load High-speed Operation Load Waiting Time	F332
		Light-load High-speed Operation Load Detection Time	F333
		Light-load High-speed Operation Heavy Load Detection Time	F334
		Switching Load Torque During Forward Run	F335
		Heavy Load Torque During Acceleration in the Forward Direction	F336
		Heavy Load Torque During Fixed Speed in Forward Run	F337
Switching Load Torque During Reverse Run		F338	
Heavy Load Torque During Acceleration in the Reverse Direction		F339	

Program Menu Navigation			
Primary Menu	Sub Menu	Parameter Name	Parameter Number
SPECIAL CONTROL PARAMETERS	Crane/Hoist Load	Heavy Load Torque During Fixed Speed in Reverse Run	F340
		Frequency for Automatic High-speed Operation at Light Load	F341
	V/f Five Point Setting	#1 Frequency Setting	F190
		#1 Voltage Setting	F191
		#2 Frequency Setting	F192
		#2 Voltage Setting	F193
		#3 Frequency Setting	F194
		#3 Voltage Setting	F195
		#4 Frequency Setting	F196
		#4 Voltage Setting	F197
		#5 Frequency Setting	F198
		#5 Voltage Setting	F199
	Low Output Disable Function	LOD Control and Stopping Method	F731
		LOD Start Level	F732
		LOD Start Time	F733
		LOD Setpoint Boost	F734
		LOD Boost Time	F735
		LOD Feedback Level	F736
		LOD Restart Delay Time	F737
	Earth Fault	Earth Fault Alarm Level	F640
		Earth Fault Alarm Time	F641
		Earth Fault Trip Level	F642
		Earth Fault Trip Time	F643
	Special Parameters	V/f Adjustment Coefficient	F183
		0 Hz Dead Band Frequency Setting Signal	F244
		0 Hz Command Stop Function	F255
		Over Exciting Cooperation	F481
		Stall Cooperation Gain at Field Weakening Zone	F485
		Exciting Starting Rate	N/A
		Compensation Coefficient for Iron Loss	F487
		Voltage Compensation Coefficient for Dead Time	N/A
		Dead Time Compensation Enable/Disable	F489
		Dead Time Compensation Bias	F490
Switching Frequency Between Current and Voltage		F491	
Optional Analog Terminal Mark		N/A	
Current Differential Gain		F454	
Exciting Strengthening Coefficient		F480	

Program Menu Navigation			
Primary Menu	Sub Menu	Parameter Name	Parameter Number
SPECIAL CONTROL PARAMETERS	Special Parameters	Enable/Disable User Parameter Initialization During Typeform Initialization	F709
		% Current Vector Control	F482
		% Voltage Vector Control	F483
		% Constant Vector Control	F484

Direct Access Parameter Information

The HX7 ASD has the ability to allow the user direct access to the motor control functions. The functions listed below have an associated **Parameter Number** which accesses its setting. There are two ways in which the motor-control parameters may be accessed for modification: Program ⇒ *applicable menu path* or Program ⇒ Direct Access ⇒ *applicable parameter number*. Both methods access the parameter via the **Program** mode. Once accessed, the parameter may be viewed or changed.

The **Program** mode allows the user to develop an application-specific motor control profile. Motor control functions may be set to accommodate specific power and timing requirements for a given application. The configurable parameters of the **Program** mode that have user-accessible **Parameter Numbers** are listed and described below.

*Note: The setup procedures included within this section may require a **Reset** before performing the procedure. Application-specific settings may then be performed. The pre-Reset conditions may be saved (see F007).*

Direct Access Parameters/Numbers

Automatic Accel/Decel #1

Program ⇒ Fundamental Parameters

This parameter **Enables/Disables** the ability of the ASD to adjust the acceleration and deceleration rates in accordance with the applied load automatically.

The adjusted acceleration and deceleration times range from 12.5% to 800% of the programmed values for **Acceleration Time #1 (F009)** and **Deceleration Time #1 (F010)**.

Settings:

- 0 — Manual
- 1 — Automatic ACC/DEC
- 2 — Automatic ACC Only

*Note: The motor and the load must be connected prior to selecting **Automatic Accel/Decel**.*

Direct Access Number — F000

Parameter Type — **Check Box**

Factory Default — **Disabled**

Changeable During Run — **No**

Automatic Torque Boost

Program ⇒ Fundamental ⇒ Motor Set #1

This parameter allows the ASD to adjust the output torque in accordance with the applied load automatically. When enabled Autotuning is performed — the motor should be connected before performing an Autotune.

Settings:

- 0 — Disabled
- 1 — Automatic Torque Boost + Autotuning
- 2 — Sensorless Vector Control + Autotuning

Direct Access Number — F001

Parameter Type — **Selection List**

Factory Default — **Disabled**

Changeable During Run — **No**

Command Mode Selection

Program ⇒ Fundamental Parameters ⇒ Standard Mode Selection ⇒
Command Mode

The **Command Mode Selection** establishes the source of the command input for the ASD. **Command** inputs include **Run, Stop, Forward**, etc. The **Override** feature may supersede the **Command Mode Selection** setting (see [Command Mode and Frequency Mode Control on pg. 32](#)).

Settings:

- 0 — Terminal Block
- 1 — Not Used
- 2 — EOI Keypad
- 3 — RS232/RS485
- 4 — Communication Option Board

Frequency Mode 1

Program ⇒ Fundamental Parameters ⇒ Standard Mode Selection ⇒
Frequency Mode 1

The **Frequency Mode 1** setting establishes the source of the frequency-control input for the ASD. The **Override** feature may supersede the **Frequency Mode 1** setting (see [Command Mode and Frequency Mode Control on pg. 32](#)).

*Note: Only **Bolded** items from the **Settings** list below may be placed in the **Override** mode. See the section titled [Command Mode and Frequency Mode Control on pg. 32](#) for further information on the **Override** feature.*

Settings:

- Use VI/II**
- Use RR
- Use RX
- Use Option Card RX2
- Use LED Keypad Option**
- Use Binary/BCD Input
- Use Common Serial (TTL)**
- Use RS232/RS485**
- Use Communication Card**
- Use Motorized Pot. Simulation
- Use Pulse Input Option

Direct Access Number — F003

Parameter Type — **Selection List**

Factory Default — **Terminal Block**

Changeable During Run — **No**

Direct Access Number — F004

Parameter Type — **Selection List**

Factory Default — **Use RR**

Changeable During Run — **No**

FM Terminal Assignment

Program ⇒ Meter Terminal Adjustment Parameters ⇒ **FM**

This parameter assigns a function to the **FM** output terminal. The **FM** output terminal produces an output current that is proportional to the magnitude of the function assigned to this terminal. The available assignments for this output terminal are listed in [Table 6 on pg. 166](#).

Note: *To read **voltage** at this terminal a 100 – 500Ω resistor is required and it must be connected from FM (+) to FM (-). The voltage is read across the 100 – 500Ω resistor.*

Current may be read by connecting an ammeter from FM (+) to FM (-).

The **FM** analog output has a maximum resolution of 1/1024. The **FM Terminal Adjustment (F006)** must be used to calibrate the output signal for a proper response. **SW-2** may be switched to allow for the full-range output to be either 0 – 1 mA or 4 – 20 mA when providing an output current, or either 0 – 1 or 1 – 7.5 volts when providing an output voltage at this terminal.

FM Terminal Adjustment

Program ⇒ Meter Terminal Adjustment Parameters ⇒ **FM**

This function is used to calibrate the **FM** analog output terminal.

To calibrate the **FM** analog output, connect a meter (current or voltage) as described at **F005**. With the drive running at a known frequency, adjust this parameter (**F006**) until the running frequency produces the desired DC level output at the **FM** terminal.

Type Reset

Program ⇒ Utility Parameters ⇒ **Type Reset**

This feature assists the user when performing fault analysis or by allowing a quick system setup change when required. Performing a **Type Reset** results in one of the following user-selected post-reset configurations.

Settings:

- None
- Auto Setup for 50 Hz
- Auto Setup for 60 Hz
- Restore Factory Defaults
- Clear Trip
- Clear Run Timer
- New Base Drive Board
- *Save User Parameters
- Restore User Parameters
- Reload EOI Flash
- Reset EOI Memory

Note: **User settings that are stored in the memory of the EOI are not saved via the **Save User Parameters** selection. The unsaved functions include the **EOI Option Setups**, (*Utility Parameters* ⇒) **Display Units**, and (*Monitor Setup* ⇒) **Scrolling Monitor Select**.*

Direct Access Number — F005

Parameter Type — **Selection List**

Factory Default — **Output Frequency**

Changeable During Run — **Yes**

Direct Access Number — F006

Parameter Type — **Numerical**

Factory Default — **512**

Changeable During Run — **Yes**

Minimum — 0

Maximum — 1280

Direct Access Number — F007

Parameter Type — **Selection List**

Factory Default — **None**

Changeable During Run — **No**

Direction (of motor rotation)

No path available (Direct Access Only)

While operating using the **LED Keypad Option** this parameter sets the direction of motor rotation. This setting may be changed during operation. This setting will not override parameter **F311 (Forward/Reverse Disable)**.

If either direction is disabled via parameter **F311**, the disabled direction will not be recognized if commanded by the **LED Keypad**. If both directions are disabled via parameter **F311**, the direction command from the **LED Keypad** will determine the direction of the motor rotation.

Settings:

- Forward
- Reverse

Note: *If using the LCD EOI, press ESC from the **Frequency Command** screen to access the Motor Direction parameter.*

Direct Access Number — F008

Parameter Type — **Selection List**

Factory Default — **Forward**

Changeable During Run — **Yes**

Accel #1 Time

Program ⇒ Fundamental Parameters ⇒ **Accel/Decel #1 Settings**

This parameter specifies the time in seconds for the drive to go from 0.0 Hz to the **Maximum Frequency** for the **#1 Acceleration** profile. The accel/decel pattern may be set using **F502**. The minimum accel/decel time may be set using **F508**.

Note: *An acceleration time shorter than the load will allow may cause nuisance tripping and mechanical stress to loads. **Automatic Accel/Decel** and **Stall** settings may lengthen the acceleration time.*

Acceleration

The acceleration rate of a motor is determined by several factors: applied power, applied load, and the physical properties of the motor (winding parameters, motor size, etc.). The ASD will control the first of these factors: input power. The settings of the ASD control the frequency and amplitude of the applied voltage to the motor.

Under most operating conditions, as the output frequency of the drive goes up so does the output voltage (linear acceleration). The ASD has the ability to modify the relationship between frequency and voltage automatically to produce smoother operation or increased (starting) torque.

Direct Access Number — F009

Parameter Type — **Numerical**

Factory Default — **(ASD-dependent)**

Changeable During Run — **Yes**

Minimum — 0.1

Maximum — 6000

Units — Seconds

Decel #1 Time

Program ⇒ Fundamental Parameters ⇒ **Accel/Decel #1 Settings**

This parameter specifies the time in seconds for the drive to go from the **Maximum Frequency** to 0.0 Hz for the **#1 Deceleration** profile. The accel/decel pattern may be set using **F502**.

When operating with the **Automatic Accel/Decel** enabled (**F000**) the minimum accel/decel time may be set using **F508**.

Note: *A deceleration time shorter than the load will allow may cause nuisance tripping and mechanical stress to loads. **Automatic Accel/Decel** and **Stall** settings may lengthen the acceleration time.*

Direct Access Number — F010

Parameter Type — **Numerical**

Factory Default — **(ASD-dependent)**

Changeable During Run — **Yes**

Minimum — 0.1

Maximum — 6000

Units — Seconds

<p>Maximum Frequency</p> <p>Program ⇒ Fundamental Parameters ⇒ Frequency Settings</p> <p>This setting determines the absolute maximum frequency that the ASD can output.</p> <p>Accel/decel times are calculated based on the Maximum Frequency setting.</p> <p><i>Note:</i> This setting may not be lower than the Upper Limit setting (F012).</p>	<p>Direct Access Number — F011</p> <p>Parameter Type — Numerical</p> <p>Factory Default — 80.0</p> <p>Changeable During Run — No</p> <p>Minimum — 30.0</p> <p>Maximum — 299.0</p> <p>Units — Hz</p>
<p>Upper Limit Frequency</p> <p>Program ⇒ Fundamental Parameters ⇒ Frequency Settings</p> <p>This parameter sets the highest frequency that the ASD will accept as a frequency command or frequency setpoint. The ASD may output frequencies higher than the Upper Limit Frequency (but, lower than the Maximum Frequency) when operating in the PID Control mode, Torque Control mode, or the Vector Control modes (sensorless or feedback).</p> <p><i>Note:</i> This setting may not be higher than the Maximum Frequency (F011) setting.</p>	<p>Direct Access Number — F012</p> <p>Parameter Type — Numerical</p> <p>Factory Default — 80.0</p> <p>Changeable During Run — Yes</p> <p>Minimum — 0.0</p> <p>Maximum — Max. Freq. (F011)</p> <p>Units — Hz</p>
<p>Lower Limit Frequency</p> <p>Program ⇒ Fundamental Parameters ⇒ Frequency Settings</p> <p>This parameter sets the lowest frequency that the ASD will accept as a frequency command or frequency setpoint. The ASD will output frequencies lower than the Lower Limit Frequency when accelerating to the lower limit or decelerating to a stop. Frequencies below the Lower Limit may also be output when operating in the PID Control mode, Torque Control mode, or the Vector Control modes (sensorless or feedback).</p>	<p>Direct Access Number — F013</p> <p>Parameter Type — Numerical</p> <p>Factory Default — 0.0</p> <p>Changeable During Run — Yes</p> <p>Minimum — 0.0</p> <p>Maximum — Upper Limit (F012)</p> <p>Units — Hz</p>
<p>Motor #1 Base Frequency</p> <p>Program ⇒ Fundamental Parameters ⇒ Motor Set #1</p> <p>The Base Frequency setting determines the <u>frequency</u> at which the output <u>voltage</u> of the ASD reaches its maximum setting. The maximum voltage setting cannot be more than the input voltage (see Maximum Output Voltage at F306). There are four Base Frequency profile settings: #1 – #4.</p> <p><i>Note:</i> For proper motor operation, the Base Frequency is normally set for the name-plated frequency of the motor.</p>	<p>Direct Access Number — F014</p> <p>Parameter Type — Numerical</p> <p>Factory Default — 60.0</p> <p>Changeable During Run — Yes</p> <p>Minimum — 25.0</p> <p>Maximum — 299.0</p> <p>Units — Hz</p>

V/f Pattern

Program ⇒ Fundamental Parameters ⇒ **Frequency Settings**

This function establishes the relationship between the output frequency and the output voltage.

Settings:

- Constant Torque
- Variable Torque
- Automatic Torque Boost
- Sensorless Vector Control (speed)
- Auto Torque Boost with Automatic Energy Savings
- Sensorless Vector Control (speed) with Automatic Energy Savings
- V/f 5-Point Setting (opens 5-point setting screen)
- Sensorless Vector Control (speed/torque switching)
- PG Feedback Vector Control (speed/torque switching)
- PG Feedback Vector Control (speed/position switching)

Note: For proper operation, the carrier frequency must be 2.2 kHz or above except while operating in the **Constant Torque, Variable Torque, or the 5-Point Setting** modes.

The **Automatic Torque Boost** and the **Sensorless Vector Control** selections use the motor tuning parameters of the drive to properly configure the ASD for the motor being used. If **Load Reactors** or **Long Lead Filters** are used, or if the capacity of the ASD is greater than the motor, manual tuning of the motor parameters may be required for optimum performance.

Motor #1 Torque Boost

Program ⇒ Fundamental Parameters ⇒ **Motor Set #1**

The **Motor #1 Torque Boost** function is used to increase the low frequency torque for high-inertia loads by increasing the output voltage at frequencies below ½ of the **#1 Base Frequency (F014)** setting.

The value programmed as a boost percentage establishes an output voltage vs. output frequency relationship to be used to start the motor or to provide smoother operation.

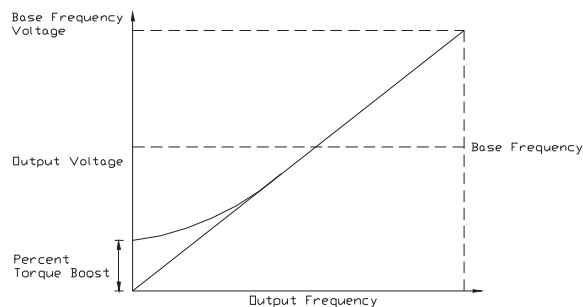

Note: Setting an excessive **Torque Boost** level may cause nuisance tripping and mechanical stress to loads.

Direct Access Number — F015

Parameter Type — **Selection List**

Factory Default — **Constant Torque**

Changeable During Run — **No**

Direct Access Number — F016

Parameter Type — **Numerical**

Factory Default — **(ASD-dependent)**

Changeable During Run — **Yes**

Minimum — 0.0

Maximum — 30.0

Units — %

Soft StallProgram ⇒ Protection Parameters ⇒ **Overload**

This parameter **Enables/Disables** the **Soft Stall** function. When enabled, the **Soft Stall** function reduces the output frequency of the ASD when the current requirements of the motor exceed the **Electronic Thermal Protection #1** setting (**F600**); thus, reducing the output current.

If the current drops below the motor overload protection level setting within a specified time, the output of the ASD will accelerate to the programmed frequency setpoint. If not, a trip will be incurred.

The **Soft Stall** feature is available when the (Program ⇒ Protection Parameters ⇒ Overload ⇒) **Motor Overload Trip Enable/Disable** parameter is enabled only.

Soft Stall is highly effective in preventing motor overload trips when used on fans, blowers, pumps, and other centrifugal loads which require less torque at lower frequencies.

*Note: The **Soft Stall** setting may affect acceleration times and patterns.*

Settings:

- Disabled
- Enabled (box checked)

Direct Access Number — F017Parameter Type — **Check Box**Factory Default — **Disabled**Changeable During Run — **No**

Preset Speed #1

Program ⇒ Pattern Run Control ⇒ Preset Speeds ⇒ 1

Up to 15 output frequency values that fall within the **Lower Limit** and the **Upper Limit** range may be programmed into the drive and output as a **Preset Speed**. This parameter assigns an output frequency to binary number 0001 and is identified as **Preset Speed #1**. The binary number is applied to **S1 – S4** of the **Control Terminal Strip** to output the **Preset Speed**.

Perform the following setup to allow the system to receive **Preset Speed** control input at the **S1 – S4** terminals:

1. Program ⇒ Fundamental Parameters ⇒ Standard Mode Selection ⇒ **Use Control Terminal Strip**.
2. Program ⇒ Terminal Selection Parameters ⇒ Input Terminals ⇒ **S1** (set to **Preset Speed Command 1**; LSB of 4-bit count). Repeat for **S2 – S4** (MSB of 4-bit count) as **Preset Speed Command 2 – 4**, respectively (all **Normally Open**).

Note: The default setting of **S4** is **EOFF**, but this terminal may be re-assigned as the **MSB**.

3. Program ⇒ Frequency Setting Parameters ⇒ Preset Speeds ⇒ 1 (press **Enter** twice and set an output frequency as **Preset Speed #1**; repeat for **Preset Speeds 2 – 15** as required).
4. Program ⇒ Frequency Setting Parameters ⇒ Preset Speed Mode ⇒ **Use Speed Modes (Enable/Disable)**.

When **Enabled**, the direction, accel/decel, and torque settings of the **Preset Speed** being run are used.

When **Disabled**, only the speed setting of the **Preset Speed** being run is used.

5. Place the system in the **Remote** mode (**Local|Remote LED Off**).
6. Provide a **Run** command (connect **F** and/or **R** to **CC**).

Connect **S1** to **CC** to run **Preset Speed #1** (**S1** to **CC** = 0001 binary).

With **S1 – S4** configured to output **Preset Speeds (F115 – F118)**, 0001 – 1111 may be applied to **S1 – S4** of the **Control Terminal Strip** to run the associated **Preset Speed**. If bidirectional operation is required, **F** and **R** must be connected to **CC**, and **Use Speed Modes** must be enabled at **F380**.

With **S1** being the least significant bit of a binary count, the **S1 – S4** settings will produce the programmed speed settings as indicated in the Preset Speed Truth Table to the right.

Preset Speeds are also used in the **Pattern Run** mode.

Preset Speed #2

Program ⇒ Pattern Run Control ⇒ Preset Speeds ⇒ 2

This parameter assigns an output frequency to binary number 0010 and is identified as **Preset Speed #2**. The binary number is applied to **S1 – S4** of the **Control Terminal Strip** to output the **Preset Speed** (see **F018** for further information on this parameter).

Direct Access Number — F018

Parameter Type — **Numerical**

Factory Default — **0.0**

Changeable During Run — **Yes**

Minimum — **Lower Limit (F013)**

Maximum — **Upper Limit (F012)**

Units — Hz

Preset Speed Truth Table.

Preset	S4 MSB	S3	S2	S1 LSB	Output
1	0	0	0	1	F018
2	0	0	1	0	F019
3	0	0	1	1	F020
4	0	1	0	0	F021
5	0	1	0	1	F022
6	0	1	1	0	F023
7	0	1	1	1	F024
8	1	0	0	0	F287
9	1	0	0	1	F288
10	1	0	1	0	F289
11	1	0	1	1	F290
12	1	1	0	0	F291
13	1	1	0	1	F292
14	1	1	1	0	F293
15	1	1	1	1	F294

Note: 1 = Terminal connected to CC.

Direct Access Number — F019

Parameter Type — **Numerical**

Factory Default — **0.0**

Changeable During Run — **Yes**

Minimum — **Lower Limit (F013)**

Maximum — **Upper Limit (F012)**

Units — Hz

<p>Preset Speed #3</p> <p>Program ⇒ Pattern Run Control ⇒ Preset Speeds ⇒ 3</p> <p>This parameter assigns an output frequency to binary number 0011 and is identified as Preset Speed #3. The binary number is applied to S1 – S4 of the Control Terminal Strip to output the Preset Speed (see F018 for further information on this parameter).</p>	<p>Direct Access Number — F020</p> <p>Parameter Type — Numerical</p> <p>Factory Default — 0.0</p> <p>Changeable During Run — Yes</p> <p>Minimum — Lower Limit (F013)</p> <p>Maximum — Upper Limit (F012)</p> <p>Units — Hz</p>
<p>Preset Speed #4</p> <p>Program ⇒ Pattern Run Control ⇒ Preset Speeds ⇒ 4</p> <p>This parameter assigns an output frequency to binary number 0100 and is identified as Preset Speed #4. The binary number is applied to S1 – S4 of the Control Terminal Strip to output the Preset Speed (see F018 for further information on this parameter).</p>	<p>Direct Access Number — F021</p> <p>Parameter Type — Numerical</p> <p>Factory Default — 0.0</p> <p>Changeable During Run — Yes</p> <p>Minimum — Lower Limit (F013)</p> <p>Maximum — Upper Limit (F012)</p> <p>Units — Hz</p>
<p>Preset Speed #5</p> <p>Program ⇒ Pattern Run Control ⇒ Preset Speeds ⇒ 5</p> <p>This parameter assigns an output frequency to binary number 0101 and is identified as Preset Speed #5. The binary number is applied to S1 – S4 of the Control Terminal Strip to output the Preset Speed (see F018 for further information on this parameter).</p>	<p>Direct Access Number — F022</p> <p>Parameter Type — Numerical</p> <p>Factory Default — 0.0</p> <p>Changeable During Run — Yes</p> <p>Minimum — Lower Limit (F013)</p> <p>Maximum — Upper Limit (F012)</p> <p>Units — Hz</p>
<p>Preset Speed #6</p> <p>Program ⇒ Pattern Run Control ⇒ Preset Speeds ⇒ 6</p> <p>This parameter assigns an output frequency to binary number 0110 and is identified as Preset Speed #6. The binary number is applied to S1 – S4 of the Control Terminal Strip to output the Preset Speed (see F018 for further information on this parameter).</p>	<p>Direct Access Number — F023</p> <p>Parameter Type — Numerical</p> <p>Factory Default — 0.0</p> <p>Changeable During Run — Yes</p> <p>Minimum — Lower Limit (F013)</p> <p>Maximum — Upper Limit (F012)</p> <p>Units — Hz</p>
<p>Preset Speed #7</p> <p>Program ⇒ Pattern Run Control ⇒ Preset Speeds ⇒ 7</p> <p>This parameter assigns an output frequency to binary number 0111 and is identified as Preset Speed #7. The binary number is applied to S1 – S4 of the Control Terminal Strip to output the Preset Speed (see F018 for further information on this parameter).</p>	<p>Direct Access Number — F024</p> <p>Parameter Type — Numerical</p> <p>Factory Default — 0.0</p> <p>Changeable During Run — Yes</p> <p>Minimum — Lower Limit (F013)</p> <p>Maximum — Upper Limit (F012)</p> <p>Units — Hz</p>
<p>Low Speed Signal Output Frequency</p> <p>Program ⇒ Terminal Selection Parameters ⇒ Reach Settings</p> <p>The Low Speed Signal Output Frequency parameter sets a frequency threshold that activates the assigned output terminal so long as the ASD output is at or above this setting (see Table 7 on pg. 167 for the available output assignments).</p>	<p>Direct Access Number — F100</p> <p>Parameter Type — Numerical</p> <p>Factory Default — 0.0</p> <p>Changeable During Run — Yes</p> <p>Minimum — 0.0</p> <p>Maximum — Max. Freq. (F011)</p> <p>Units — Hz</p>

Speed Reach FrequencyProgram ⇒ Terminal Selection Parameters ⇒ **Reach Settings**

The **Speed Reach Frequency** sets a frequency threshold that, when reached or is within the bandwidth specified by parameter **F102**, will provide a signal at an output terminal that can close an appropriately configured output contact (see [Table 7 on pg. 167](#) for the available output assignments).

Direct Access Number — F101Parameter Type — **Numerical**Factory Default — **0.0**Changeable During Run — **Yes**

Minimum — 0.0

Maximum — **Max. Freq. (F011)**

Units — Hz

Speed Reach Frequency ToleranceProgram ⇒ Terminal Selection Parameters ⇒ **Reach Settings**

This parameter sets the bandwidth of the **Speed Reach Frequency (F101)** setting.

Direct Access Number — F102Parameter Type — **Numerical**Factory Default — **2.5**Changeable During Run — **Yes**

Minimum — 0.0

Maximum — **Max. Freq. (F011)**

Units — Hz

ST Signal Selection

Program ⇒ Terminal Selection Parameters ⇒ **Input Special Functions**

This parameter is used to set the operation of the **Standby (ST)** control terminal or any terminal configured as the **ST** terminal.

Settings:

- ST-to-CC Required
- ST-to-CC Not Required
- Interlock with F/R Terminal

The setting **ST-to-CC Required** enables the ASD for operation so long as the control terminal **ST** is connected to **CC** via a jumper, contact, or other means.

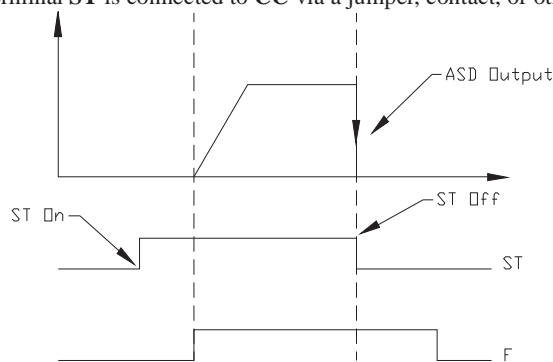

The **ST-to-CC Not Required** setting allows the ASD to operate without the **ST-to-CC** connection. The control terminal **ST** may be configured for other functions.

The **Interlock with F/R Terminal** setting configures the **F (Forward)** and **R (Reverse)** control terminals for the secondary function of **Standby**. Closing a set of contacts to either **F** or **R** will cause the ASD to accelerate the motor to the programmed setpoint of **F** or **R**. Opening the **F** and **R** contact will disable the ASD and the motor will coast to a stop. The control terminal **ST** may be configured for other functions.

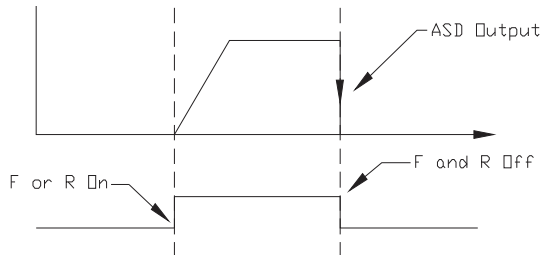

R/F Priority Selection

Program ⇒ Terminal Selection Parameters ⇒ **Input Special Functions**

The **R/F Priority Selection** determines the operation of the ASD if both the **R** and **F** control terminals are activated.

Settings:

- Reverse
- Suspend

The waveforms below depict the motor response for all combinations of the **F** and **R** terminal settings if the **Reverse** option is chosen.

The **Suspend** setting will decelerate the motor to a stop regardless of the rotation direction when both the **F** and **R** control terminals are activated.

Direct Access Number — F103

Parameter Type — **Selection List**

Factory Default — **ST – CC Required**

Changeable During Run — **No**

Direct Access Number — F105

Parameter Type — **Selection List**

Factory Default — **Reverse**

Changeable During Run — **No**

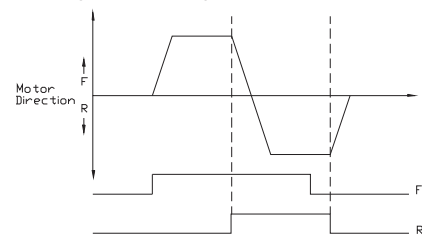

Input Terminal Priority

Program ⇒ Terminal Selection Parameters ⇒ **Input Special Functions**

This parameter is used to allow the **Jog** and **DC Injection Braking** input signals to control the ASD when received via the **Control Terminal Strip** even though the system is in the **Local** mode.

With this parameter enabled, a **Jog** command or a **DC Injection Braking** command received from the **Control Terminal Strip** will receive priority over commands from the **EOI**.

See **F260** for further information on using the **Jog** function.

See **F250 – F252** for further information on **DC Injection Braking**.

Settings:

- Enabled (Box checked)
- Disabled

Direct Access Number — F106

Parameter Type — **Check Box**

Factory Default — **Disabled**

Changeable During Run — **No**

Extended Terminal Function

Program ⇒ Terminal Selection Parameters ⇒ **Input Special Functions**

The **Extended Terminal Function** is used with the optional **ASD-Multicom** card only. This parameter defines the format of the binary or BCD data when using the option card.

Settings:

- None
- 12-Bit Binary
- 16-Bit Binary
- 3-Digit BCD
- 4-Digit BCD
- Reverse 12-Bit Binary
- Reverse 16-Bit Binary
- Reverse 3-Digit BCD
- Reverse 4-Digit BCD

Selections using 16-bit binary or 4-digit BCD will require the configuration of terminals S1-S4 on the **Control Terminal Strip** as binary bits 0 – 3 (**F115 – F118**). The **Frequency Mode 1 Selection (F004)** must be set to **Use Binary/BCD Input**.

For proper scaling of the binary or BCD input, parameters **F228 – F231** must be configured [**BIN Reference Point #1**, **BIN Reference #1 (frequency)**, **Bin Reference Point #2**, and **BIN Reference #2 (frequency)**].

Direct Access Number — F107

Parameter Type — **Selection List**

Factory Default — **None**

Changeable During Run — **No**

<p>Motorized Pot Frequency at Power Down</p> <p>Program ⇒ Frequency Setting Parameters ⇒ Motorized Pot Settings</p> <p>When the Frequency Mode 1 Selection (F004) setting is set to Use MOP Function Simulation, this parameter determines the outcome of the Frequency Mode 1 setting at powerdown or stop.</p> <p>Settings:</p> <ul style="list-style-type: none"> Erase Store <p>If Erase is selected, the ASD will not store the frequency setpoint and establishes a setpoint of 0.0 Hz when restarted.</p> <p>If Store is selected, the ASD will maintain the current frequency setpoint in memory while stopped, during fault conditions, or when power is removed. This setpoint will be used as the initial frequency setpoint when the ASD is restarted.</p> <p>A control terminal configured as MOP Frequency Clear will establish a frequency setpoint of 0.0 Hz regardless of the Motorized Pot Frequency at Power Down setting.</p>	<p>Direct Access Number — F108</p> <p>Parameter Type — Selection List</p> <p>Factory Default — Erase</p> <p>Changeable During Run — No</p>
<p>ON Input Terminal Assignment</p> <p>Program ⇒ Terminal Selection Parameters ⇒ Input Terminal Assignment ⇒ ON</p> <p>This parameter selects the functionality of the virtual input terminal ON. As a virtual terminal, the ON control terminal exists only in memory and is considered to always be in its True (or connected to CC) state.</p> <p>It is often practical to assign this terminal to a function that the user desires to be maintained regardless of external conditions or operations.</p> <p>This parameter sets the programmable ON terminal to 1 of the 68 possible functions that are listed in Table 5 on pg. 162.</p>	<p>Direct Access Number — F110</p> <p>Parameter Type — Selection List</p> <p>Factory Default — Unassigned</p> <p>Changeable During Run — No</p>
<p>F Input Terminal Assignment</p> <p>Program ⇒ Terminal Selection Parameters ⇒ Input Terminal Assignment ⇒ F</p> <p>This parameter selects the functionality of the F input terminal.</p> <p>In addition, the input terminal must be specified as Normally Open or Normally Closed.</p> <p>This parameter sets the programmable F terminal to 1 of the 68 possible functions that are listed in Table 5 on pg. 162.</p>	<p>Direct Access Number — F111</p> <p>Parameter Type — Selection List</p> <p>Factory Default — Forward</p> <p>Changeable During Run — No</p>
<p>R Input Terminal Assignment</p> <p>Program ⇒ Terminal Selection Parameters ⇒ Input Terminal Assignment ⇒ R</p> <p>This parameter selects the functionality of the R input terminal.</p> <p>In addition, the input terminal must be specified as Normally Open or Normally Closed.</p> <p>This parameter sets the programmable R terminal to 1 of the 68 possible functions that are listed in Table 5 on pg. 162.</p>	<p>Direct Access Number — F112</p> <p>Parameter Type — Selection List</p> <p>Factory Default — Reverse</p> <p>Changeable During Run — No</p>

<p>ST Input Terminal Assignment</p> <p>Program ⇒ Terminal Selection Parameters ⇒ Input Terminal Assignment ⇒ ST</p> <p>This parameter selects the functionality of the ST input terminal.</p> <p>In addition, the input terminal must be specified as Normally Open or Normally Closed.</p> <p>This parameter sets the programmable ST terminal to 1 of the 68 possible functions that are listed in Table 5 on pg. 162.</p>	<p>Direct Access Number — F113</p> <p>Parameter Type — Selection List</p> <p>Factory Default — Standby</p> <p>Changeable During Run — No</p>
<p>RES Input Terminal Assignment</p> <p>Program ⇒ Terminal Selection Parameters ⇒ Input Terminal Assignment ⇒ RES</p> <p>This parameter selects the functionality of the RES input terminal.</p> <p>In addition, the input terminal must be specified as Normally Open or Normally Closed.</p> <p>This parameter sets the programmable RES terminal to 1 of the 68 possible functions that are listed in Table 5 on pg. 162.</p>	<p>Direct Access Number — F114</p> <p>Parameter Type — Selection List</p> <p>Factory Default — Reset</p> <p>Changeable During Run — No</p>
<p>S1 Input Terminal Assignment</p> <p>Program ⇒ Terminal Selection Parameters ⇒ Input Terminal Assignment ⇒ S1</p> <p>This parameter selects the functionality of the S1 input terminal.</p> <p>In addition, the input terminal must be specified as Normally Open or Normally Closed.</p> <p>This parameter sets the programmable S1 terminal to 1 of the 68 possible functions that are listed in Table 5 on pg. 162.</p>	<p>Direct Access Number — F115</p> <p>Parameter Type — Selection List</p> <p>Factory Default — Preset Speed Cmd #1</p> <p>Changeable During Run — No</p>
<p>S2 Input Terminal Assignment</p> <p>Program ⇒ Terminal Selection Parameters ⇒ Input Terminal Assignment ⇒ S2</p> <p>This parameter selects the functionality of the S2 input terminal.</p> <p>In addition, the input terminal must be specified as Normally Open or Normally Closed.</p> <p>This parameter sets the programmable S2 terminal to 1 of the 68 possible functions that are listed in Table 5 on pg. 162.</p>	<p>Direct Access Number — F116</p> <p>Parameter Type — Selection List</p> <p>Factory Default — Preset Speed Cmd #2</p> <p>Changeable During Run — No</p>
<p>S3 Input Terminal Assignment</p> <p>Program ⇒ Terminal Selection Parameters ⇒ Input Terminal Assignment ⇒ S3</p> <p>This parameter selects the functionality of the S3 input terminal.</p> <p>In addition, the input terminal must be specified as Normally Open or Normally Closed.</p> <p>This parameter sets the programmable S3 terminal to 1 of the 68 possible functions that are listed in Table 5 on pg. 162.</p>	<p>Direct Access Number — F117</p> <p>Parameter Type — Selection List</p> <p>Factory Default — Preset Speed Cmd #3</p> <p>Changeable During Run — No</p>

<p>S4 Input Terminal Assignment</p> <p>Program ⇒ Terminal Selection Parameters ⇒ Input Terminal Assignment ⇒ S4</p> <p>This parameter selects the functionality of the S4 input terminal.</p> <p>In addition, the input terminal must be specified as Normally Open or Normally Closed.</p> <p>This parameter sets the programmable S4 terminal to 1 of the 68 possible functions that are listed in Table 5 on pg. 162.</p>	<p>Direct Access Number — F118</p> <p>Parameter Type — Selection List</p> <p>Factory Default — Emergency Off</p> <p>Changeable During Run — No</p>
<p>S5 Input Terminal Assignment</p> <p>Program ⇒ Terminal Selection Parameters ⇒ Input Terminal Assignment ⇒ S5</p> <p>This parameter selects the functionality of the S5 input terminal.</p> <p><i>Note:</i> <i>The S5 input terminal may be used without the ASD-Multicom option board.</i></p> <p><i>Without the ASD-Multicom option board the S5 terminal assignment information will be stored in volatile memory. The terminal assignment information will be lost if the system is powered down or reset.</i></p> <p>In addition, the input terminal must be specified as Normally Open or Normally Closed.</p> <p>This parameter sets the programmable S5 terminal to 1 of the 68 possible functions that are listed in Table 5 on pg. 162.</p>	<p>Direct Access Number — F119</p> <p>Parameter Type — Selection List</p> <p>Factory Default — Unassigned</p> <p>Changeable During Run — No</p>
<p>S6 Input Terminal Assignment</p> <p>Program ⇒ Terminal Selection Parameters ⇒ Input Terminal Assignment ⇒ S6</p> <p>This parameter selects the functionality of the S6 input terminal.</p> <p><i>Note:</i> <i>The S6 input terminal may be used without the ASD-Multicom option board.</i></p> <p><i>Without the ASD-Multicom option board the S6 terminal assignment information will be stored in volatile memory. The terminal assignment information will be lost if the system is powered down or reset.</i></p> <p>In addition, the input terminal must be specified as Normally Open or Normally Closed.</p> <p>This parameter sets the programmable S6 terminal to 1 of the 68 possible functions that are listed in Table 5 on pg. 162.</p>	<p>Direct Access Number — F120</p> <p>Parameter Type — Selection List</p> <p>Factory Default — Unassigned</p> <p>Changeable During Run — No</p>

S7 Input Terminal Assignment

Program ⇒ Terminal Selection Parameters ⇒ Input Terminal Assignment ⇒ **S7**

This parameter selects the functionality of the **S7** input terminal.

Note: *The S7 input terminal may be used without the ASD-Multicom option board.*

Without the ASD-Multicom option board the S7 terminal assignment information will be stored in volatile memory. The terminal assignment information will be lost if the system is powered down or reset.

In addition, the input terminal must be specified as **Normally Open** or **Normally Closed**.

This parameter sets the programmable **S7** terminal to 1 of the 68 possible functions that are listed in [Table 5 on pg. 162](#).

Direct Access Number — F121

Parameter Type — Selection List

Factory Default — Unassigned

Changeable During Run — No

Input Terminal 12 Assignment

Program ⇒ Terminal Selection Parameters ⇒ Input Terminal Assignment ⇒ **12**

This parameter selects the functionality of the **#12** input terminal.

Note: *The #12 input terminal may be used without the ASD-Multicom option board.*

Without the ASD-Multicom option board the #12 terminal assignment information will be stored in volatile memory. The terminal assignment information will be lost if the system is powered down or reset.

In addition, the input terminal must be specified as **Normally Open** or **Normally Closed**.

This parameter sets the programmable terminal **#12** to 1 of the 68 possible functions that are listed in [Table 5 on pg. 162](#).

Direct Access Number — F122

Parameter Type — Selection List

Factory Default — Unassigned

Changeable During Run — No

Input Terminal 13 Assignment

Program ⇒ Terminal Selection Parameters ⇒ Input Terminal Assignment ⇒ **13**

This parameter selects the functionality of the **#13** input terminal.

Note: *The #13 input terminal may be used without the ASD-Multicom option board.*

Without the ASD-Multicom option board the #13 terminal assignment information will be stored in volatile memory. The terminal assignment information will be lost if the system is powered down or reset.

In addition, the input terminal must be specified as **Normally Open** or **Normally Closed**.

This parameter sets the programmable terminal **#13** to 1 of the 68 possible functions that are listed in [Table 5 on pg. 162](#).

Direct Access Number — F123

Parameter Type — Selection List

Factory Default — Unassigned

Changeable During Run — No

Input Terminal 14 Assignment

Program ⇒ Terminal Selection Parameters ⇒ Input Terminal Assignment ⇒ **14**

This parameter selects the functionality of the **#14** input terminal.

Note: *The #14 input terminal may be used without the ASD-Multicom option board.*

Without the ASD-Multicom option board the #14 terminal assignment information will be stored in volatile memory. The terminal assignment information will be lost if the system is powered down or reset.

In addition, the input terminal must be specified as **Normally Open** or **Normally Closed**.

This parameter sets the programmable terminal **#14** to 1 of the 68 possible functions that are listed in [Table 5 on pg. 162](#).

Direct Access Number — F124

Parameter Type — **Selection List**

Factory Default — **Unassigned**

Changeable During Run — **No**

Input Terminal 15 Assignment

Program ⇒ Terminal Selection Parameters ⇒ Input Terminal Assignment ⇒ **15**

This parameter selects the functionality of the **#15** input terminal.

Note: *The #15 input terminal may be used without the ASD-Multicom option board.*

Without the ASD-Multicom option board the #15 terminal assignment information will be stored in volatile memory. The terminal assignment information will be lost if the system is powered down or reset.

In addition, the input terminal must be specified as **Normally Open** or **Normally Closed**.

This parameter sets the programmable terminal **#15** to 1 of the 68 possible functions that are listed in [Table 5 on pg. 162](#).

Direct Access Number — F125

Parameter Type — **Selection List**

Factory Default — **Unassigned**

Changeable During Run — **No**

Input Terminal 16 Assignment

Program ⇒ Terminal Selection Parameters ⇒ Input Terminal Assignment ⇒ **16**

This parameter selects the functionality of the **#16** input terminal.

Note: *The #16 input terminal may be used without the ASD-Multicom option board.*

Without the ASD-Multicom option board the #16 terminal assignment information will be stored in volatile memory. The terminal assignment information will be lost if the system is powered down or reset.

In addition, the input terminal must be specified as **Normally Open** or **Normally Closed**.

This parameter sets the programmable terminal **#16** to 1 of the 68 possible functions that are listed in [Table 5 on pg. 162](#).

Direct Access Number — F126

Parameter Type — **Selection List**

Factory Default — **Unassigned**

Changeable During Run — **No**

OUT1 Output Terminal Assignment

Program ⇒ Terminal Selection Parameters ⇒ Output Terminal Assignment ⇒ **OUT1**

This parameter sets the functionality of the **OUT1 (A & C)** output terminals to 1 of the 62 possible functions that are listed in [Table 7 on pg. 167](#).

The on and off delay times of the **OUT1** terminals may be adjusted to provide more response time to the device that is connected to the output terminals.

In addition, the output terminals must be specified as **Normally Open** or **Normally Closed**.

Direct Access Number — F130

Parameter Type — Selection List

Factory Default — Low

Changeable During Run — No

OUT2 Output Terminal Assignment

Program ⇒ Terminal Selection Parameters ⇒ Output Terminal Assignment ⇒ **OUT2**

This parameter sets the functionality of the **OUT2 (A & C)** output terminals to 1 of the 62 possible functions that are listed in [Table 7 on pg. 167](#).

The on and off delay times of the **OUT2** terminals may be adjusted to provide more response time to the device that is connected to the output terminals.

In addition, the output terminals must be specified as **Normally Open** or **Normally Closed**.

Direct Access Number — F131

Parameter Type — Selection List

Factory Default — RCH (Acc/Dec Complete)

Changeable During Run — No

FL Output Terminal Assignment

Program ⇒ Terminal Selection Parameters ⇒ Output Terminal Assignment ⇒ **FL**

This parameter sets the functionality of the **FL** output terminals to 1 of the 62 possible functions that are listed in [Table 7 on pg. 167](#).

The on and off delay times of the **FL** terminals may be adjusted to provide more response time to the device that is connected to the output terminals.

In addition, the output terminals must be specified as **Normally Open** or **Normally Closed**.

Direct Access Number — F132

Parameter Type — Selection List

Factory Default — Fault (All)

Changeable During Run — No

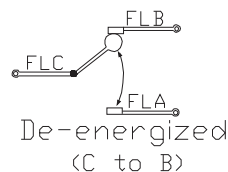
**Output #4 Terminal Assignment**

Program ⇒ Terminal Selection Parameters ⇒ Output Terminal Assignment ⇒ **4**

This parameter sets the functionality of the **OUT4** terminals to 1 of the 62 possible functions that are listed in [Table 7 on pg. 167](#).

The on and off delay times of the **OUT4** terminals may be adjusted to provide more response time to the device that is connected to the output terminals.

In addition, the output terminals must be specified as **Normally Open** or **Normally Closed**.

Direct Access Number — F133

Parameter Type — Selection List

Factory Default — LL

Changeable During Run — No

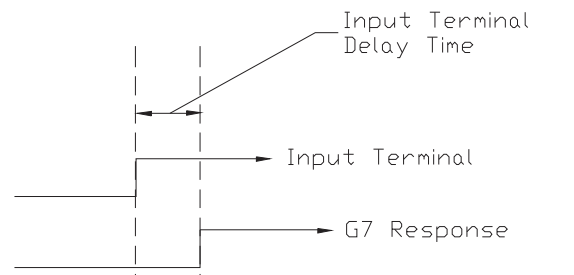
<p>OUT5 Terminal Assignment</p> <p>Program ⇒ Terminal Selection Parameters ⇒ Output Terminal Assignment ⇒ 5</p> <p>This parameter sets the functionality of the OUT5 terminals to 1 of the 62 possible functions that are listed in Table 7 on pg. 167.</p> <p>The on and off delay times of the OUT5 terminals may be adjusted to provide more response time to the device that is connected to the output terminals.</p> <p>In addition, the output terminals must be specified as Normally Open or Normally Closed.</p>	<p>Direct Access Number — F134</p> <p>Parameter Type — Selection List</p> <p>Factory Default — UL</p> <p>Changeable During Run — No</p>
<p>OUT6 Terminal Assignment</p> <p>Program ⇒ Terminal Selection Parameters ⇒ Output Terminal Assignment ⇒ 6</p> <p>This parameter sets the functionality of the OUT6 terminals to 1 of the 62 possible functions that are listed in Table 7 on pg. 167.</p> <p>The on and off delay times of the OUT6 terminals may be adjusted to provide more response time to the device that is connected to the output terminals.</p> <p>In addition, the output terminals must be specified as Normally Open or Normally Closed.</p>	<p>Direct Access Number — F135</p> <p>Parameter Type — Selection List</p> <p>Factory Default — RCH (Specified Speed)</p> <p>Changeable During Run — No</p>
<p>OUT7 Terminal Assignment</p> <p>Program ⇒ Terminal Selection Parameters ⇒ Output Terminal Assignment ⇒ 7</p> <p>This parameter sets the functionality of the OUT7 terminals to 1 of the 62 possible functions that are listed in Table 7 on pg. 167.</p> <p>The on and off delay times of the OUT7 terminals may be adjusted to provide more response time to the device that is connected to the output terminals.</p> <p>In addition, the output terminals must be specified as Normally Open or Normally Closed.</p>	<p>Direct Access Number — F136</p> <p>Parameter Type — Selection List</p> <p>Factory Default — Overcurrent Prealarm</p> <p>Changeable During Run — No</p>
<p>F Input Terminal Delay</p> <p>Program ⇒ Terminal Selection Parameters ⇒ Input Terminal Delays ⇒ F</p> <p>This parameter delays the response of the ASD to any change in the F terminal input by the programmed value.</p>  <p>The delay may be increased to provide additional electrical noise immunity or to prevent the ASD from responding to contact bounce or chatter.</p>	<p>Direct Access Number — F140</p> <p>Parameter Type — Numerical</p> <p>Factory Default — 8.0</p> <p>Changeable During Run — No</p> <p>Minimum — 2.0</p> <p>Maximum — 200.0</p> <p>Units — mS</p>

<p>R Input Terminal Delay</p> <p>Program ⇒ Terminal Selection Parameters ⇒ Input Terminal Delays ⇒ R</p> <p>This parameter delays the response of the drive to any change in the R terminal input by the programmed value (see waveforms at F140).</p> <p>The delay may be increased to provide additional electrical noise immunity or to prevent the ASD from responding to contact bounce or chatter.</p>	<p>Direct Access Number — F141</p> <p>Parameter Type — Numerical</p> <p>Factory Default — 8.0</p> <p>Changeable During Run — No</p> <p>Minimum — 2.0</p> <p>Maximum — 200.0</p> <p>Units — mS</p>
<p>ST Input Terminal Delay</p> <p>Program ⇒ Terminal Selection Parameters ⇒ Input Terminal Delays ⇒ ST</p> <p>This parameter delays the response of the drive to any change in the ST terminal input by the programmed value (see waveforms at F140).</p> <p>The delay may be increased to provide additional electrical noise immunity or to prevent the ASD from responding to contact bounce or chatter.</p>	<p>Direct Access Number — F142</p> <p>Parameter Type — Numerical</p> <p>Factory Default — 8.0</p> <p>Changeable During Run — No</p> <p>Minimum — 2.0</p> <p>Maximum — 200.0</p> <p>Units — mS</p>
<p>RES Input Terminal Delay</p> <p>Program ⇒ Terminal Selection Parameters ⇒ Input Terminal Delays ⇒ RES</p> <p>This parameter delays the response of the drive to any change in the RES terminal input by the programmed value (see waveforms at F140).</p> <p>The delay may be increased to provide additional electrical noise immunity or to prevent the ASD from responding to contact bounce or chatter.</p>	<p>Direct Access Number — F143</p> <p>Parameter Type — Numerical</p> <p>Factory Default — 8.0</p> <p>Changeable During Run — No</p> <p>Minimum — 2.0</p> <p>Maximum — 200.0</p> <p>Units — mS</p>
<p>S1 – S4 Input Terminal Delay</p> <p>Program ⇒ Terminal Selection Parameters ⇒ Input Terminal Delays ⇒ S1 – S4</p> <p>This parameter delays the response of the drive to any change in the S1 – S4 terminal input by the programmed value (see waveforms at F140).</p> <p>The delay may be increased to provide additional electrical noise immunity or to prevent the ASD from responding to contact bounce or chatter.</p>	<p>Direct Access Number — F144</p> <p>Parameter Type — Numerical</p> <p>Factory Default — 8.0</p> <p>Changeable During Run — No</p> <p>Minimum — 2.0</p> <p>Maximum — 200.0</p> <p>Units — mS</p>
<p>S5 – S16 Input Terminal Delay</p> <p>Program ⇒ Terminal Selection Parameters ⇒ Input Terminal Delays ⇒ S5 – S16</p> <p>This parameter delays the response of the drive to any change in the S5 – S16 terminal input by the programmed value (see waveforms at F140).</p> <p>The delay may be increased to provide additional electrical noise immunity or to prevent the ASD from responding to contact bounce or chatter.</p>	<p>Direct Access Number — F145</p> <p>Parameter Type — Numerical</p> <p>Factory Default — 8.0</p> <p>Changeable During Run — No</p> <p>Minimum — 2.0</p> <p>Maximum — 200.0</p> <p>Units — mS</p>

OUT1 On Delay

Program ⇒ Terminal Selection Parameters ⇒ Output Terminal Delays ⇒ **OUT1**

Once the condition is met to close the **OUT1** (A & C) output terminals, this parameter delays the closing of the terminals by the programmed value.

For example, if the **OUT1** function is programmed as **Overtorque Alarm**, **OUT1** will close 2.0 mS (the default value for **OUT1 On Delay**) after the overtorque condition occurs.

The delay may be increased to prevent relay chatter.

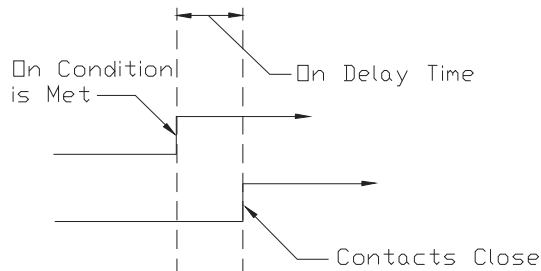

Direct Access Number — F150

Parameter Type — **Numerical**

Factory Default — **2.0**

Changeable During Run — **No**

Minimum — 2.0

Maximum — 200.0

Units — mS

OUT2 On Delay

Program ⇒ Terminal Selection Parameters ⇒ Output Terminal Delays ⇒ **OUT2**

This parameter delays the closing of the **OUT2** (A & C) output terminals by the programmed value (see waveforms at **F150**).

The delay may be increased to prevent relay chatter.

Direct Access Number — F151

Parameter Type — **Numerical**

Factory Default — **2.0**

Changeable During Run — **No**

Minimum — 2.0

Maximum — 200.0

Units — mS

FL On Delay

Program ⇒ Terminal Selection Parameters ⇒ Output Terminal Delays ⇒ **FL**

This parameter delays the closing of the **FL** output terminals by the programmed value (see waveforms at **F150**).

The delay may be increased to prevent relay chatter.

Direct Access Number — F152

Parameter Type — **Numerical**

Factory Default — **2.0**

Changeable During Run — **No**

Minimum — 2.0

Maximum — 200.0

Units — mS

OUT4 On Delay

Program ⇒ Terminal Selection Parameters ⇒ Output Terminal Delays ⇒ **OUT4**

This parameter delays the closing of the **OUT4** output terminals by the programmed value (see waveforms at **F150**).

The delay may be increased to prevent relay chatter.

Direct Access Number — F153

Parameter Type — **Numerical**

Factory Default — **2.0**

Changeable During Run — **No**

Minimum — 2.0

Maximum — 200.0

Units — mS

<p>OUT5 On Delay</p> <p>Program ⇒ Terminal Selection Parameters ⇒ Output Terminal Delays ⇒ OUT5</p> <p>This parameter delays the closing of the OUT5 output terminals by the programmed value (see waveforms at F150).</p> <p>The delay may be increased to prevent relay chatter.</p>	<p>Direct Access Number — F154</p> <p>Parameter Type — Numerical</p> <p>Factory Default — 2.0</p> <p>Changeable During Run — No</p> <p>Minimum — 2.0</p> <p>Maximum — 200.0</p> <p>Units — mS</p>
--------------------------------------------------------------------------------------------------------------------------------------------------------------------------------------------------------------------------------------------------------------------------------------------------------------------	-------------------------------------------------------------------------------------------------------------------------------------------------------------------------------------------------------------------------------

<p>OUT6 On Delay</p> <p>Program ⇒ Terminal Selection Parameters ⇒ Output Terminal Delays ⇒ OUT6</p> <p>This parameter delays the closing of the OUT6 output terminals by the programmed value (see waveforms at F150).</p> <p>The delay may be increased to prevent relay chatter.</p>	<p>Direct Access Number — F155</p> <p>Parameter Type — Numerical</p> <p>Factory Default — 2.0</p> <p>Changeable During Run — No</p> <p>Minimum — 2.0</p> <p>Maximum — 200.0</p> <p>Units — mS</p>
--------------------------------------------------------------------------------------------------------------------------------------------------------------------------------------------------------------------------------------------------------------------------------------------------------------------	-------------------------------------------------------------------------------------------------------------------------------------------------------------------------------------------------------------------------------

<p>OUT7 On Delay</p> <p>Program ⇒ Terminal Selection Parameters ⇒ Output Terminal Delays ⇒ OUT7</p> <p>This parameter delays the closing of the OUT7 output terminals by the programmed value (see waveforms at F150).</p> <p>The delay may be increased to prevent relay chatter.</p>	<p>Direct Access Number — F156</p> <p>Parameter Type — Numerical</p> <p>Factory Default — 2.0</p> <p>Changeable During Run — No</p> <p>Minimum — 2.0</p> <p>Maximum — 200.0</p> <p>Units — mS</p>
--------------------------------------------------------------------------------------------------------------------------------------------------------------------------------------------------------------------------------------------------------------------------------------------------------------------	-------------------------------------------------------------------------------------------------------------------------------------------------------------------------------------------------------------------------------

<p>OUT1 Off Delay</p> <p>Program ⇒ Terminal Selection Parameters ⇒ Output Terminal Delays ⇒ OUT1</p> <p>This parameter delays the opening of the OUT1 (A & C) output terminals by the programmed value.</p> <p>The delay may be increased to allow the devices that are connected to OUT1 to respond.</p>	<p>Direct Access Number — F160</p> <p>Parameter Type — Numerical</p> <p>Factory Default — 2.0</p> <p>Changeable During Run — No</p> <p>Minimum — 2.0</p> <p>Maximum — 200.0</p> <p>Units — mS</p>
-------------------------------------------------------------------------------------------------------------------------------------------------------------------------------------------------------------------------------------------------------------------------------------------------------------------------------------------	-------------------------------------------------------------------------------------------------------------------------------------------------------------------------------------------------------------------------------

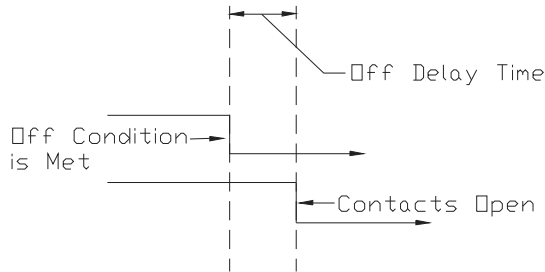

<p>OUT2 Off Delay</p> <p>Program ⇒ Terminal Selection Parameters ⇒ Output Terminal Delays ⇒ OUT2</p> <p>This parameter delays the opening of the OUT2 (A & C) output terminals by the programmed value (see waveforms at F160).</p> <p>The delay may be increased to allow the devices that are connected to OUT2 to respond.</p>	<p>Direct Access Number — F161</p> <p>Parameter Type — Numerical</p> <p>Factory Default — 2.0</p> <p>Changeable During Run — No</p> <p>Minimum — 2.0</p> <p>Maximum — 200.0</p> <p>Units — mS</p>
--------------------------------------------------------------------------------------------------------------------------------------------------------------------------------------------------------------------------------------------------------------------------------------------------------------------------------------------------------------------------	-------------------------------------------------------------------------------------------------------------------------------------------------------------------------------------------------------------------------------

<p>FL Off Delay</p> <p>Program ⇒ Terminal Selection Parameters ⇒ Output Terminal Delays ⇒ FL</p> <p>This parameter delays the opening of the FL output terminals by the programmed value (see waveforms at F160).</p> <p>The delay may be increased to allow the devices that are connected to FL to respond.</p>	<p>Direct Access Number — F162</p> <p>Parameter Type — Numerical</p> <p>Factory Default — 2.0</p> <p>Changeable During Run — No</p> <p>Minimum — 2.0</p> <p>Maximum — 200.0</p> <p>Units — mS</p>
<p>OUT4 Off Delay</p> <p>Program ⇒ Terminal Selection Parameters ⇒ Output Terminal Delays ⇒ OUT4</p> <p>This parameter delays the opening of the OUT4 output terminals by the programmed value (see waveforms at F160).</p> <p>The delay may be increased to allow the devices that are connected to OUT4 to respond.</p>	<p>Direct Access Number — F163</p> <p>Parameter Type — Numerical</p> <p>Factory Default — 2.0</p> <p>Changeable During Run — No</p> <p>Minimum — 2.0</p> <p>Maximum — 200.0</p> <p>Units — mS</p>
<p>OUT5 Off Delay</p> <p>Program ⇒ Terminal Selection Parameters ⇒ Output Terminal Delays ⇒ OUT5</p> <p>This parameter delays the opening of the OUT5 output terminals by the programmed value (see waveforms at F160).</p> <p>The delay may be increased to allow the devices that are connected to OUT5 to respond.</p>	<p>Direct Access Number — F164</p> <p>Parameter Type — Numerical</p> <p>Factory Default — 2.0</p> <p>Changeable During Run — No</p> <p>Minimum — 2.0</p> <p>Maximum — 200.0</p> <p>Units — mS</p>
<p>OUT6 Off Delay</p> <p>Program ⇒ Terminal Selection Parameters ⇒ Output Terminal Delays ⇒ OUT6</p> <p>This parameter delays the opening of the OUT6 output terminals by the programmed value (see waveforms at F160).</p> <p>The delay may be increased to allow the devices that are connected to OUT6 to respond.</p>	<p>Direct Access Number — F165</p> <p>Parameter Type — Numerical</p> <p>Factory Default — 2.0</p> <p>Changeable During Run — No</p> <p>Minimum — 2.0</p> <p>Maximum — 200.0</p> <p>Units — mS</p>
<p>OUT7 Off Delay</p> <p>Program ⇒ Terminal Selection Parameters ⇒ Output Terminal Delays ⇒ OUT7</p> <p>This parameter delays the opening of the OUT7 output terminals by the programmed value (see waveforms at F160).</p> <p>The delay may be increased to allow the devices that are connected to OUT7 to respond.</p>	<p>Direct Access Number — F166</p> <p>Parameter Type — Numerical</p> <p>Factory Default — 2.0</p> <p>Changeable During Run — No</p> <p>Minimum — 2.0</p> <p>Maximum — 200.0</p> <p>Units — mS</p>

<p>Motor #2 Base Frequency</p> <p>Program ⇒ Motor Parameters ⇒ Motor Set #2</p> <p>The Motor #2 Base Frequency setting is the frequency at which the output voltage of the ASD reaches its maximum setting. The #2 Maximum Output Voltage is set at F171.</p> <p>This parameter is used only when the parameters for motor set #2 are configured and selected. Motor set #2 may be selected by a properly configured input terminal.</p> <p>For proper motor operation, the Base Frequency should be set for the name-plated frequency of the motor.</p>	<p>Direct Access Number — F170</p> <p>Parameter Type — Numerical</p> <p>Factory Default — 60.0</p> <p>Changeable During Run — Yes</p> <p>Minimum — 25.0</p> <p>Maximum — 299.0</p> <p>Units — Hz</p>
<p>Motor #2 Max Output Voltage</p> <p>Program ⇒ Motor Parameters ⇒ Motor Set #2</p> <p>The Motor #2 Maximum Output Voltage is the Motor #2 output voltage at the Base Frequency (F170). Regardless of the programmed value, the output voltage cannot be higher than the input voltage.</p> <p>The actual output voltage will be influenced by the input voltage of the ASD and the Supply Voltage Compensation setting (F307).</p> <p>This parameter is used only when the parameters for motor set #2 are configured and selected. Motor set #2 may be selected by a properly configured input terminal.</p>	<p>Direct Access Number — F171</p> <p>Parameter Type — Numerical</p> <p>Factory Default — (ASD-dependent)</p> <p>Changeable During Run — Yes</p> <p>Minimum — 0.0</p> <p>Maximum — 600.0</p> <p>Units — Volts</p>
<p>Motor #2 Torque Boost</p> <p>Program ⇒ Motor Parameters ⇒ Motor Set #2</p> <p>The Motor #2 Torque Boost function is used to increase the low frequency torque for high inertia loads by increasing the output voltage at frequencies below ½ of the #2 Base Frequency setting (F170).</p> <p>See parameter F016 (Motor #1 Torque Boost) for an explanation of torque boost.</p> <p>This parameter is used only when the parameters for motor set #2 are configured and selected. Motor set #2 may be selected by a properly configured input terminal.</p>	<p>Direct Access Number — F172</p> <p>Parameter Type — Numerical</p> <p>Factory Default — (ASD-dependent)</p> <p>Changeable During Run — Yes</p> <p>Minimum — 0.0</p> <p>Maximum — 30.0</p> <p>Units — %</p>
<p>Electronic Thermal Protection #2</p> <p>Program ⇒ Motor Parameters ⇒ Motor Set #2</p> <p>The Motor #2 Electronic Thermal Protection parameter specifies the motor overload current level for motor set #2. This value is entered as either a percentage of the full load rating of the ASD or as the FLA of the motor.</p> <p>The unit of measurement for this parameter may be set to Amps (V/A) or it may be set as a percentage of the ASD rating. The name-plated FLA of the motor may be entered directly when Amps is selected as the unit of measurement (see F701 to change the display unit).</p> <p>Electronic Thermal Protection settings (#1 – #4) will be displayed in Amps if the EOI display units are set to V/A rather than %.</p>	<p>Direct Access Number — F173</p> <p>Parameter Type — Numerical</p> <p>Factory Default — 100.0</p> <p>Changeable During Run — Yes</p> <p>Minimum — 10.0</p> <p>Maximum — 100.0</p> <p>Units — %</p>

<p>Motor #3 Base Frequency</p> <p>Program ⇒ Motor Parameters ⇒ Motor Set #3</p> <p>The Motor #3 Base Frequency setting is the frequency at which the output voltage of the ASD reaches its maximum setting. The Maximum Output Voltage is set at F175.</p> <p>This parameter is used only when the parameters for motor set #3 are configured and selected. Motor set #3 may be selected by a properly configured input terminal.</p> <p>For proper motor operation, the Base Frequency should be set for the name-plated frequency of the motor.</p>	<p>Direct Access Number — F174</p> <p>Parameter Type — Numerical</p> <p>Factory Default — 60.0</p> <p>Changeable During Run — Yes</p> <p>Minimum — 25.0</p> <p>Maximum — 299.0</p> <p>Units — Hz</p>
<p>Motor #3 Max Output Voltage</p> <p>Program ⇒ Motor Parameters ⇒ Motor Set #3</p> <p>The Motor #3 Maximum Output Voltage is the Motor #3 output voltage at the Base Frequency (F174). Regardless of the programmed value, the output voltage cannot be higher than the input voltage.</p> <p>The actual output voltage will be influenced by the input voltage of the ASD and the Supply Voltage Compensation setting (F307).</p> <p>This parameter is used only when the parameters for motor set #3 are configured and selected. Motor set #3 may be selected by a properly configured input terminal.</p>	<p>Direct Access Number — F175</p> <p>Parameter Type — Numerical</p> <p>Factory Default — (ASD-dependent)</p> <p>Changeable During Run — Yes</p> <p>Minimum — 0.0</p> <p>Maximum — 600.0</p> <p>Units — Volts</p>
<p>Motor #3 Torque Boost</p> <p>Program ⇒ Motor Parameters ⇒ Motor Set #3</p> <p>The Motor #3 Torque Boost function is used to increase the low frequency torque for high inertia loads by increasing the output voltage at frequencies below ½ of the #3 Base Frequency setting (F174).</p> <p>See parameter F016 (Motor #1 Torque Boost) for an explanation of torque boost.</p> <p>This parameter is used only when the parameters for motor set #3 are configured and selected. Motor set #3 may be selected by a properly configured input terminal.</p>	<p>Direct Access Number — F176</p> <p>Parameter Type — Numerical</p> <p>Factory Default — (ASD-dependent)</p> <p>Changeable During Run — Yes</p> <p>Minimum — 0.0</p> <p>Maximum — 30.0</p> <p>Units — %</p>
<p>Electronic Thermal Protection #3</p> <p>Program ⇒ Motor Parameters ⇒ Motor Set #3</p> <p>The Motor #3 Electronic Thermal Protection parameter specifies the motor overload current level for motor set #3. This value is entered as either a percentage of the full load rating of the ASD or as the FLA of the motor.</p> <p>The unit of measurement for this parameter may be set to Amps (V/A) or it may be set as a percentage of the ASD rating. The name-plated FLA of the motor may be entered directly when Amps is selected as the unit of measurement (see F701 to change the display unit).</p> <p>Electronic Thermal Protection settings (#1 – #4) will be displayed in Amps if the EOI display units are set to V/A rather than %.</p>	<p>Direct Access Number — F177</p> <p>Parameter Type — Numerical</p> <p>Factory Default — 100.0</p> <p>Changeable During Run — Yes</p> <p>Minimum — 10.0</p> <p>Maximum — 100.0</p> <p>Units — %</p>

<p>Motor #4 Base Frequency</p> <p>Program ⇒ Motor Parameters ⇒ Motor Set #4</p> <p>The Motor #4 Base Frequency setting is the frequency at which the output voltage of the ASD reaches its maximum setting. The Maximum Output Voltage is set at F179.</p> <p>This parameter is used only when the parameters for motor set #4 are configured and selected. Motor set #4 may be selected by a properly configured input terminal.</p> <p>For proper motor operation, the Base Frequency should be set for the name-plated frequency of the motor.</p>	<p>Direct Access Number — F178</p> <p>Parameter Type — Numerical</p> <p>Factory Default — 60.0</p> <p>Changeable During Run — Yes</p> <p>Minimum — 25.0</p> <p>Maximum — 299.0</p> <p>Units — Hz</p>
<p>Motor #4 Max Output Voltage</p> <p>Program ⇒ Motor Parameters ⇒ Motor Set #4</p> <p>The Motor #3 Maximum Output Voltage is the Motor #4 output voltage at the Base Frequency (F178). Regardless of the programmed value, the output voltage cannot be higher than the input voltage.</p> <p>The actual output voltage will be influenced by the input voltage of the ASD and the Supply Voltage Compensation setting (F307).</p> <p>This parameter is used only when the parameters for motor set #4 are configured and selected. Motor set #4 may be selected by a properly configured input terminal.</p>	<p>Direct Access Number — F179</p> <p>Parameter Type — Numerical</p> <p>Factory Default — (ASD-dependent)</p> <p>Changeable During Run — Yes</p> <p>Minimum — 0.0</p> <p>Maximum — 600.0</p> <p>Units — Volts</p>
<p>Motor #4 Torque Boost</p> <p>Program ⇒ Motor Parameters ⇒ Motor Set #4</p> <p>The Motor #4 Torque Boost function is used to increase the low frequency torque for high inertia loads by increasing the output voltage at frequencies below ½ of the #4 Base Frequency setting (F178).</p> <p>See parameter F016 (Motor #1 Torque Boost) for an explanation of torque boost.</p> <p>This parameter is used only when the parameters for motor set #4 are configured and selected. Motor set #4 may be selected by a properly configured input terminal.</p>	<p>Direct Access Number — F180</p> <p>Parameter Type — Numerical</p> <p>Factory Default — (ASD-dependent)</p> <p>Changeable During Run — Yes</p> <p>Minimum — 0.0</p> <p>Maximum — 30.0</p> <p>Units — %</p>
<p>Electronic Thermal Protection #4</p> <p>Program ⇒ Motor Parameters ⇒ Motor Set #4</p> <p>The Motor #4 Electronic Thermal Protection parameter specifies the motor overload current level for motor set #4. This value is entered as either a percentage of the full load rating of the ASD or as the FLA of the motor.</p> <p>The unit of measurement for this parameter may be set to Amps (V/A) or it may be set as a percentage of the ASD rating. The name-plated FLA of the motor may be entered directly when Amps is selected as the unit of measurement (see F701 to change the display unit).</p> <p>Electronic Thermal Protection settings (#1 – #4) will be displayed in Amps if the EOI display units are set to V/A rather than %.</p>	<p>Direct Access Number — F181</p> <p>Parameter Type — Numerical</p> <p>Factory Default — 100.0</p> <p>Changeable During Run — Yes</p> <p>Minimum — 10.0</p> <p>Maximum — 100.0</p> <p>Units — %</p>

V/f Adjustment Coefficient

Program ⇒ Special Control Parameters ⇒ Special Parameters ⇒ **V/f Adjustment Coefficient**

This parameter may be used in the **Constant Torque** or the **Variable Torque** modes only and should be adjusted gradually to improve the application-specific torque requirements. The **Torque Boost** setting (**F016**) may be adjusted to improve the low-frequency torque performance.

Note: The **Torque Boost** setting should be adjusted gradually before attempting performance corrections using this parameter.

Direct Access Number — F183

Parameter Type — Numerical

Factory Default — 32

Changeable During Run — Yes

Minimum — 0

Maximum — 255

Custom V/f Five-Point Setting #1 Frequency

Program ⇒ Special Control Parameters ⇒ **V/f Five-Point Setting**

The **Custom V/f Five-Point Setting #1 Frequency** setting establishes the frequency that is to be associated with the voltage setting of **F191 (Custom V/f Five-Point Setting #1 Voltage)**.

The V/f five-point settings define a custom volts per hertz relationship for the startup output of the ASD.

To enable this function, set the **V/f Pattern (F015)** selection to **Custom V/f Curve**.

Custom V/f Curves may be useful in starting high inertia loads such as rotary drum vacuum filters.

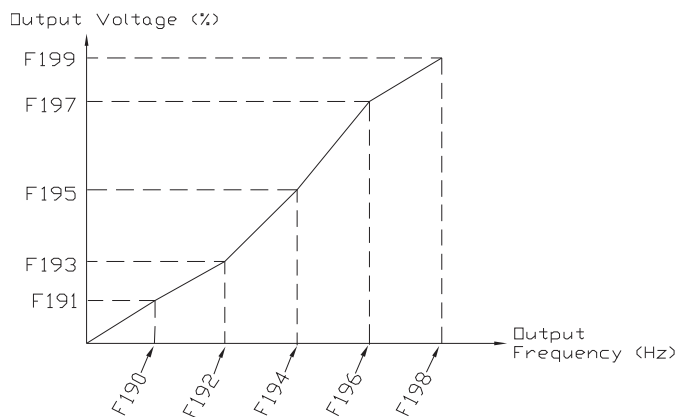

Direct Access Number — F190

Parameter Type — Numerical

Factory Default — 0.0

Changeable During Run — No

Minimum — 0.0

Maximum — 299

Units — Hz

Custom V/f Five-Point Setting #1 Voltage

Program ⇒ Special Control Parameters ⇒ **V/f Five-Point Setting**

The **Custom V/f Five-Point Setting #1 Voltage** establishes the percentage of the output voltage that is to be associated with the frequency setting of **F190 (Custom V/f Five-Point Setting #1 Frequency)**.

See **F190** for additional information on custom V/f curves.

Direct Access Number — F191

Parameter Type — Numerical

Factory Default — 0.00

Changeable During Run — No

Minimum — 0.0

Maximum — 100.0

Units — %

Custom V/f Five-Point Setting #2 Frequency

Program ⇒ Special Control Parameters ⇒ **V/f Five-Point Setting**

The **Custom V/f Five Point Setting #2 Frequency** sets the frequency to be associated with parameter **F193 (Custom V/f Five Point Setting #2 Voltage)**.

See **F190** for additional information on custom V/f curves.

Direct Access Number — F192

Parameter Type — Numerical

Factory Default — 0.0

Changeable During Run — No

Minimum — 0.0

Maximum — 299

Units — Hz

<p>Custom V/f Five-Point Setting #2 Voltage</p> <p>Program ⇒ Special Control Parameters ⇒ V/f Five-Point Setting</p> <p>The Custom V/f Five-Point Setting #2 Voltage establishes the percentage of the output voltage that is to be associated with the frequency setting of F192 (Custom V/f Five Point Setting #2 Frequency).</p> <p>See F190 for additional information on custom V/f curves.</p>	<p>Direct Access Number — F193</p> <p>Parameter Type — Numerical</p> <p>Factory Default — 0.0</p> <p>Changeable During Run — No</p> <p>Minimum — 0.0</p> <p>Maximum — 100.0</p> <p>Units — %</p>
<p>Custom V/f Five-Point Setting #3 Frequency</p> <p>Program ⇒ Special Control Parameters ⇒ V/f Five-Point Setting</p> <p>The Custom V/f Five Point Setting #3 Frequency sets the frequency to be associated with parameter F195 (Custom V/f Five Point Setting #3 Voltage).</p> <p>See F190 for additional information on custom V/f curves.</p>	<p>Direct Access Number — F194</p> <p>Parameter Type — Numerical</p> <p>Factory Default — 0.0</p> <p>Changeable During Run — No</p> <p>Minimum — 0.0</p> <p>Maximum — 299</p> <p>Units — Hz</p>
<p>Custom V/f Five-Point Setting #3 Voltage</p> <p>Program ⇒ Special Control Parameters ⇒ V/f Five-Point Setting</p> <p>The Custom V/f Five-Point Setting #3 Voltage establishes the percentage of the output voltage that is to be associated with the frequency setting of F194 (Custom V/f Five Point Setting #3 Frequency).</p> <p>See F190 for additional information on custom V/f curves.</p>	<p>Direct Access Number — F195</p> <p>Parameter Type — Numerical</p> <p>Factory Default — 0.0</p> <p>Changeable During Run — No</p> <p>Minimum — 0.0</p> <p>Maximum — 100.0</p> <p>Units — %</p>
<p>Custom V/f Five-Point Setting #4 Frequency</p> <p>Program ⇒ Special Control Parameters ⇒ V/f Five-Point Setting</p> <p>The Custom V/f Five Point Setting #4 Frequency sets the frequency to be associated with parameter F197 (Custom V/f Five Point Setting #4 Voltage).</p> <p>See F190 for additional information on custom V/f curves.</p>	<p>Direct Access Number — F196</p> <p>Parameter Type — Numerical</p> <p>Factory Default — 0.0</p> <p>Changeable During Run — No</p> <p>Minimum — 0.0</p> <p>Maximum — 299</p> <p>Units — Hz</p>
<p>Custom V/f Five-Point Setting #4 Voltage</p> <p>Program ⇒ Special Control Parameters ⇒ V/f Five-Point Setting</p> <p>The Custom V/f Five-Point Setting #4 Voltage establishes the percentage of the output voltage that is to be associated with the frequency setting of F196 (Custom V/f Five Point Setting #4 Frequency).</p> <p>See F190 for additional information on custom V/f curves.</p>	<p>Direct Access Number — F197</p> <p>Parameter Type — Numerical</p> <p>Factory Default — 0.0</p> <p>Changeable During Run — No</p> <p>Minimum — 0.0</p> <p>Maximum — 100.0</p> <p>Units — %</p>
<p>Custom V/f Five-Point Setting #5 Frequency</p> <p>Program ⇒ Special Control Parameters ⇒ V/f Five-Point Setting</p> <p>The Custom V/f Five Point Setting #5 Frequency sets the frequency to be associated with parameter F199 (Custom V/f Five Point Setting #5 Voltage).</p> <p>See F190 for additional information on custom V/f curves.</p>	<p>Direct Access Number — F198</p> <p>Parameter Type — Numerical</p> <p>Factory Default — 0.0</p> <p>Changeable During Run — No</p> <p>Minimum — 0.0</p> <p>Maximum — 299</p> <p>Units — Hz</p>

Custom V/f Five-Point Setting #5 Voltage

Program ⇒ Special Control Parameters ⇒ **V/f Five-Point Setting**

The **Custom V/f Five-Point Setting #5 Voltage** establishes the percentage of the output voltage that is to be associated with the frequency setting of **F198** (**Custom V/f Five Point Setting #5 Frequency**).

See **F190** for additional information on custom V/f curves.

Direct Access Number — F199

Parameter Type — Numerical

Factory Default — 0.0

Changeable During Run — No

Minimum — 0.0

Maximum — 100.0

Units — %

Reference Priority Selection

Program ⇒ Fundamental Parameters ⇒ Standard Mode Selection ⇒ **Reference Priority Selection**

Either **Frequency Mode 1** or **Frequency Mode 2** may control the output frequency of the ASD. This parameter determines which of the two will control the output frequency and the conditions in which control will be switched from one to the other.

Settings:

- Frequency Source #1
- Frequency Source #2
- Frequency Source #1 Priority
- Frequency Source #2 Priority
- Frequency Source Priority Switching

The **Frequency Source #1** or **#2** setting specifies the source of the input frequency command signal. These settings are performed in **F004** and **F207**, respectively.

If **Frequency Source #1** is selected here, the ASD will follow the settings of **F004**. If **Frequency Source #2** is selected here, the ASD will follow the settings of **F207**.

The **Frequency Source #1 Priority** and **Frequency Source #2 Priority** selections are used in conjunction with the **Mode #1/#2 Switching Frequency** setting (**F208**). Parameter **F208** establishes a threshold frequency that will be used as a reference when determining when to switch output control between the **Frequency Mode 1** setting and the **Frequency Mode 2** setting.

If **Frequency Source #1 Priority** is selected here and the commanded frequency of **Frequency Source #1** exceeds the **F208** setting, the **Frequency Mode 1** setting has priority over the **Frequency Mode 2** setting.

If **Frequency Source #2 Priority** is selected here and the commanded frequency of **Frequency Source #2** exceeds the **F208** setting, the **Frequency Mode 2** setting has priority over **Frequency Mode 1** setting.

Frequency Source Priority Switching allows for a preconfigured input terminal to activate **Frequency Source #1** or **Frequency Source #2**. Any unused programmable discrete input terminal may be programmed as the **Frequency Priority** switching terminal.

Direct Access Number — F200

Parameter Type — Selection List

Factory Default — Frequency Source #1

Changeable During Run — Yes

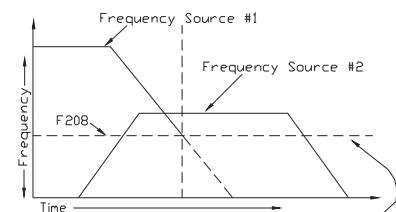

Once the commanded frequency exceeds the F208 value, the setting of parameter F200 determines if the #1 or the #2 frequency command source controls the ASD output.

VI/II Speed Reference #1

Program ⇒ Frequency Setting Parameters ⇒ Speed Reference Setpoints ⇒ **VI/II**

This parameter is used to set the gain and bias of the **VI/II** input terminal when the **VI/II** terminal is used as the control input while operating in the **Speed Control** mode or the **Torque Control** mode.

Note: See note on pg. 50 for further information on the VI/II terminal.

VI/II Input Speed Control Setup

Perform the following setup to allow the system to receive **Speed** control input at the **VI/II** input terminal:

- Program ⇒ Fundamental Parameters ⇒ Standard Mode Selection ⇒ Frequency Mode 1 ⇒ **VI/II**.
- Program ⇒ Fundamental Parameters ⇒ Standard Mode Selection ⇒ Command Mode ⇒ **Use Control Terminal Strip**.
- Set **VI/II Speed Reference #1 (F201)** — the input signal level that represents **VI/II Speed Frequency #1**.
- Set **VI/II Speed Frequency #1 (F202)**.
- Set **VI/II Speed Reference #2 (F203)** — the input signal level that represents **VI/II Speed Frequency #2**.
- Set **VI/II Speed Frequency #2 (F204)**.
- Provide a **Run** command (**F** and/or **R**).

Once set, as the **VI** input voltage or the **II** current changes, the output frequency of the ASD will vary in accordance with the above settings.

This parameter sets **VI/II Speed Reference #1** and is the input signal level that is associated with the setting of **VI/II Speed Frequency #1** while operating in the **Speed Control** mode.

VI/II Input Torque Control Setup

Perform the following setup to allow the system to receive **Torque** control input at the **VI/II** input terminal:

- Program ⇒ Fundamental Parameters ⇒ Standard Mode Selection ⇒ Frequency Mode 1 ⇒ **VI/II**.
- Program ⇒ Fundamental Parameters ⇒ Standard Mode Selection ⇒ Command Mode ⇒ **Use Control Terminal Strip**.
- Set **VI/II Speed Reference #1 (F201)** — the input signal level that represents **VI/II Torque Reference Setpoint #1**.
- Set **VI/II Torque Reference Setpoint #1 (F205)**.
- Set **VI/II Speed Reference #2 (F203)** — the input signal level that represents **VI/II Torque Reference Setpoint #2**.
- Set **VI/II Torque Reference Setpoint #2 (F206)**.
- Provide a **Run** command (**F** and/or **R**).

Once set, as the **VI** input voltage or the **II** current changes, the output torque of the ASD will vary in accordance with the above settings.

This parameter sets **VI/II Speed Reference #1** and is the input signal level that is associated with the setting of **VI/II Torque Reference Setpoint #1** while operating in the **Torque Control** mode.

Direct Access Number — F201

Parameter Type — Numerical

Factory Default — 20.0

Changeable During Run — Yes

Minimum — 0.0

Maximum — 100.0

Units — %

Frequency Settings

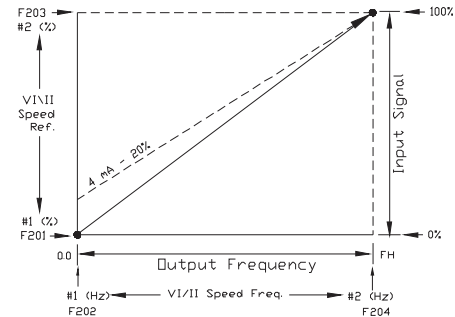

Note: The default value for parameter **F201** is 20%. The **II** input is commonly used for the 4 – 20 mA current loop signal where 4 mA equals 20% of a 20 mA signal. If the **VI** input is used (0 – 10 VDC input), this parameter may be changed to 0.0% (of the input signal).

Note: The speed control response may be further trimmed by adjusting the **Bias** and **Gain** settings.

Torque Settings

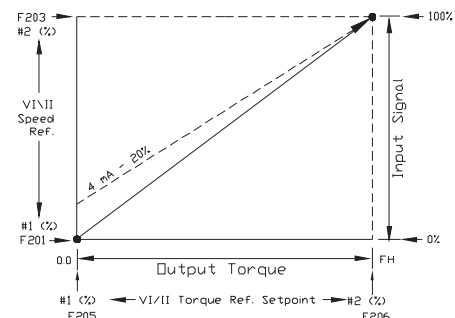

<p>VI/II Speed Frequency #1</p> <p>Program ⇒ Frequency Setting Parameters ⇒ Speed Reference Setpoints ⇒ VI/II</p> <p>This parameter is used to set the gain and bias of the VI/II input terminal when the VI/II terminal is used as the control input while operating in the Speed Control mode.</p> <p>See VI/II Speed Reference #1 (F201) for further information on this setting.</p> <p>This parameter sets VI/II Speed Frequency #1 and is the frequency that is associated with the setting of VI/II Speed Reference #1 while operating in the Speed Control mode.</p>	<p>Direct Access Number — F202</p> <p>Parameter Type — Numerical</p> <p>Factory Default — 0.0</p> <p>Changeable During Run — Yes</p> <p>Minimum — 0.0</p> <p>Maximum — Max. Freq. (F011)</p> <p>Units — Hz</p>
<p>VI/II Speed Reference #2</p> <p>Program ⇒ Frequency Setting Parameters ⇒ Speed Reference Setpoints ⇒ VI/II</p> <p>This parameter is used to set the gain and bias of the VI/II input terminal when the VI/II terminal is used as the control input while operating in the Speed Control mode or the Torque Control mode.</p> <p>See VI/II Speed Reference #1 for further information on this setting when used for Speed control or Torque control.</p> <p>This parameter sets the VI/II input level that is associated with VI/II Speed Frequency #2 while operating in the Speed control mode or is associated with the VI/II Torque Reference Setpoint #2 while operating in the Torque control mode.</p>	<p>Direct Access Number — F203</p> <p>Parameter Type — Numerical</p> <p>Factory Default — 100.00</p> <p>Changeable During Run — Yes</p> <p>Minimum — 0.0</p> <p>Maximum — 100.0</p> <p>Units — %</p>
<p>VI/II Speed Frequency #2</p> <p>Program ⇒ Frequency Setting Parameters ⇒ Speed Reference Setpoints ⇒ VI/II</p> <p>This parameter is used to set the gain and bias of the VI/II input terminal when the VI/II terminal is used as the control input while operating in the Speed Control mode.</p> <p>See VI/II Speed Reference #1 for further information on this setting when used for Speed control.</p> <p>This parameter sets the output frequency that is associated with VI/II Speed Reference #2 setting while operating in the Speed control mode.</p>	<p>Direct Access Number — F204</p> <p>Parameter Type — Numerical</p> <p>Factory Default — 80.00</p> <p>Changeable During Run — Yes</p> <p>Minimum — 0.0</p> <p>Maximum — Max. Freq. (F011)</p> <p>Units — Hz</p>
<p>VI/II Torque Reference Setpoint #1</p> <p>Program ⇒ Torque Setting Parameters ⇒ Setpoints ⇒ VI/II</p> <p>This parameter is used to set the gain and bias of the VI/II input terminal when the VI/II terminal is used as the control input while operating in the Torque Control mode.</p> <p>This is accomplished by establishing an associated V/f output pattern for a given VI/II input level.</p> <p>See VI/II Speed Reference #1 for further information on this setting.</p> <p>This parameter sets VI/II Torque Reference Setpoint #1 and is the output torque value that is associated with the setting of VI/II Speed Reference #1 while operating in the Torque control mode.</p>	<p>Direct Access Number — F205</p> <p>Parameter Type — Numerical</p> <p>Factory Default — 0.00</p> <p>Changeable During Run — Yes</p> <p>Minimum — 0.00</p> <p>Maximum — 250.0</p> <p>Units — %</p>

VI/II Torque Reference Setpoint #2

Program ⇒ Torque Setting Parameters ⇒ Setpoints ⇒ **VI/II**

This parameter is used to set the gain and bias of the **VI/II** input terminal when the **VI/II** terminal is used as the control input while operating in the **Torque Control** mode.

This is accomplished by establishing an associated **V/f** output pattern for a given **VI/II** input level.

See **VI/II Speed Reference #1** for further information on this setting.

This parameter sets **VI/II Torque Reference Setpoint #2** and is the output torque value that is associated with setting of **VI/II Speed Reference #2** while operating in the **Torque** control mode.

Direct Access Number — F206

Parameter Type — **Numerical**

Factory Default — **100.00**

Changeable During Run — **Yes**

Minimum — 0.00

Maximum — 250.0

Units — %

Frequency Mode 2

Program ⇒ Fundamental Parameters ⇒ **Standard Mode Selection**

This parameter selects the source of the frequency command signal to be used as **Frequency Mode 2** in the event that **Frequency Mode 1** is disabled or if **Frequency Mode 2** is set up as the primary control parameter. See **F004** and **F200** for additional information on this setting.

Settings:

Use VI/II

Use RR

Use RX

Use Option Card RX2

Use LED Keypad Option

Use Binary/BCD Input

Use Common Serial (TTL)

Use RS232/RS485

Use Communication Card

Use Motorized Pot. Simulation

Use Pulse Input Option

Direct Access Number — F207

Parameter Type — **Selection List**

Factory Default — **VI/II**

Changeable During Run — **Yes**

Mode #1/#2 Switching Frequency

Program ⇒ Fundamental Parameters ⇒ Standard Mode Selection ⇒ **Mode #1/#2 Switching Frequency**

This parameter sets the threshold frequency that will be used in **F200** to determine if **Frequency Source #1** or **#2** will control the output of the ASD.

See **F200** for additional information on this setting.

Direct Access Number — F208

Parameter Type — **Numerical**

Factory Default — **1.0**

Changeable During Run — **Yes**

Minimum — 0.1

Maximum — **Max. Freq. (F011)**

Units — Hz

Analog Input FilterProgram ⇒ Frequency Setting Parameters ⇒ **Analog Filter**

Analog filtering is applied after the analog reference signal is converted to a digital signal. The type of filtering used is **Rolling Average** over time.

Settings:

- None
- Small
- Medium
- Large

The analog input signal is sampled and converted to a digital signal. With no filtering applied, the digital value from the conversion is scaled for use by the microprocessor of the ASD.

If the filtering selection is **Small**, the ASD averages the last 5 sampled (digital) values. The rolling average is updated (every 4 μ S) and scaled for use by the microprocessor.

If the filtering selection is **Medium**, the ASD averages the last 20 sampled (digital) values. The rolling average is updated (every 4 μ S) and scaled for use by the microprocessor.

If the filtering selection is **Large**, the ASD averages the last 50 sampled (digital) values. The rolling average is updated (every 4 μ S) and scaled for use by the microprocessor.

False responses to electrical noise are eliminated with no loss in bandwidth because the value used by the drive is the average value of several samples.

Direct Access Number — F209Parameter Type — **Selection List**Factory Default — **None**Changeable During Run — **Yes**

RR Speed Reference #1

Program ⇒ Frequency Setting Parameters ⇒ Speed Reference Setpoints ⇒ **RR**

This parameter is used to set the gain and bias of the **RR** input terminal when the **RR** terminal is used as the control input while operating in the **Speed Control** mode or the **Torque Control** mode.

RR Input Speed Control Setup

Perform the following setup to allow the system to receive **Speed** control input at the **RR** input terminal:

- Program ⇒ Fundamental Parameters ⇒ Standard Mode Selection ⇒ Frequency Mode 1 ⇒ **RR**.
- Program ⇒ Fundamental Parameters ⇒ Standard Mode Selection ⇒ Command Mode ⇒ **Use Control Terminal Strip**.
- Set **RR Speed Reference #1 (F210)** — the input signal level that represents **RR Speed Frequency #1**.
- Set **RR Speed Frequency #1 (F211)**.
- Set **RR Speed Reference #2 (F212)** — the input signal level that represents **RR Speed Frequency #2**.
- Set **RR Speed Frequency #2 (F213)**.
- Provide a **Run** command (**F** and/or **R**).

Once set, as the **RR** input changes, the output frequency of the ASD will vary in accordance with the above settings.

This parameter sets **RR Speed Reference #1** and is the input signal level that is associated with the setting of **RR Speed Frequency #1** while operating in the **Speed Control** mode.

RR Input Torque Control Setup

Perform the following setup to allow the system to receive **Torque** control input at the **RR** input terminal:

- Program ⇒ Fundamental Parameters ⇒ Standard Mode Selection ⇒ Frequency Mode 1 ⇒ **RR**.
- Program ⇒ Fundamental Parameters ⇒ Standard Mode Selection ⇒ Command Mode ⇒ **Use Control Terminal Strip**.
- Set **RR Speed Reference #1 (F210)** — the input signal level that represents **RR Torque Reference Setpoint #1**.
- Set **RR Torque Reference Setpoint #1 (F214)**.
- Set **RR Speed Reference #2 (F212)** — the input signal level that represents **RR Torque Reference Setpoint #2**.
- Set **RR Torque Reference Setpoint #2 (F215)**.
- Provide a **Run** command (**F** and/or **R**).

Once set, as the **RR** input changes, the output torque of the ASD will vary in accordance with the above settings.

This parameter sets **RR Speed Reference #1** and is the input signal level that is associated with the setting of **RR Torque Reference Setpoint #1** while operating in the **Torque Control** mode.

Direct Access Number — F210

Parameter Type — Numerical

Factory Default — 0.0

Changeable During Run — Yes

Minimum — 0.0

Maximum — 100.0

Units — %

Frequency Settings

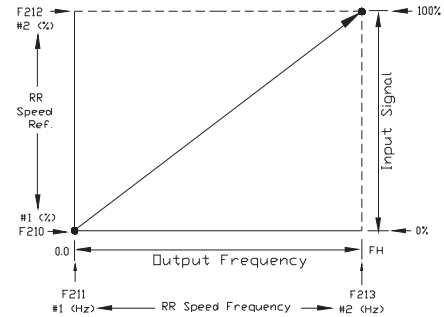

Note: *The speed control response may be further trimmed by adjusting the Bias and Gain settings.*

Torque Settings

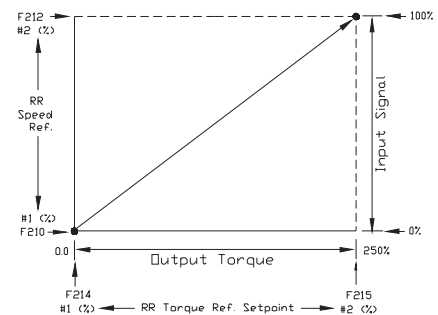

<p>RR Speed Frequency #1</p> <p>Program ⇒ Frequency Setting Parameters ⇒ Speed Reference Setpoints ⇒ RR</p> <p>This parameter is used to set the gain and bias of the RR input terminal when the RR terminal is used as the control input while operating in the Speed Control mode.</p> <p>See RR Speed Reference #1 (F210) for further information on this setting.</p> <p>This parameter sets RR Speed Frequency #1 and is the frequency that is associated with the setting of RR Speed Reference #1 while operating in the Speed Control mode.</p>	<p>Direct Access Number — F211</p> <p>Parameter Type — Numerical</p> <p>Factory Default — 0.0</p> <p>Changeable During Run — Yes</p> <p>Minimum — 0.0</p> <p>Maximum — Max. Freq. (F011)</p> <p>Units — Hz</p>
<p>RR Speed Reference #2</p> <p>Program ⇒ Frequency Setting Parameters ⇒ Speed Reference Setpoints ⇒ RR</p> <p>This parameter is used to set the gain and bias of the RR input terminal when the RR terminal is used as the control input while operating in the Speed Control mode or the Torque Control mode.</p> <p>See RR Speed Reference #1 for further information on this setting when used for Speed control or Torque control.</p> <p>This parameter sets the RR input level that is associated with RR Speed Frequency #2 while operating in the Speed control mode or is associated with the RR Torque Reference Setpoint #2 while operating in the Torque control mode.</p>	<p>Direct Access Number — F212</p> <p>Parameter Type — Numerical</p> <p>Factory Default — 100.00</p> <p>Changeable During Run — Yes</p> <p>Minimum — 0.0</p> <p>Maximum — 100.0</p> <p>Units — %</p>
<p>RR Speed Frequency #2</p> <p>Program ⇒ Frequency Setting Parameters ⇒ Speed Reference Setpoints ⇒ RR</p> <p>This parameter is used to set the gain and bias of the RR input terminal when the RR terminal is used as the control input while operating in the Speed Control mode.</p> <p>See RR Speed Reference #1 for further information on this setting when used for Speed control.</p> <p>This parameter sets RR Speed Frequency #2 and is the frequency that is associated with the setting of RR Speed Reference #2 while operating in the Speed Control mode.</p>	<p>Direct Access Number — F213</p> <p>Parameter Type — Numerical</p> <p>Factory Default — 80.00</p> <p>Changeable During Run — Yes</p> <p>Minimum — 0.0</p> <p>Maximum — Max. Freq. (F011)</p> <p>Units — Hz</p>
<p>RR Torque Reference Setpoint #1</p> <p>Program ⇒ Torque Setting Parameters ⇒ Setpoints ⇒ RR</p> <p>This parameter is used to set the gain and bias of the RR input terminal when the RR terminal is used as the control input while operating in the Torque Control mode.</p> <p>This is accomplished by establishing an associated V/f output pattern for a given RR input level.</p> <p>See RR Speed Reference #1 for further information on this setting.</p> <p>This parameter sets RR Torque Reference Setpoint #1 and is the output torque value that is associated with the setting of RR Speed Reference #1 while operating in the Torque control mode.</p>	<p>Direct Access Number — F214</p> <p>Parameter Type — Numerical</p> <p>Factory Default — 0.00</p> <p>Changeable During Run — Yes</p> <p>Minimum — 0.00</p> <p>Maximum — 250.0</p> <p>Units — %</p>

RR Torque Reference Setpoint #2

Program ⇒ Torque Setting Parameters ⇒ Setpoints ⇒ **RR**

This parameter is used to set the gain and bias of the **RR** input terminal when the **RR** terminal is used as the control input while operating in the **Torque Control** mode.

This is accomplished by establishing an associated **V/f** output pattern for a given **RR** input level.

See **RR Speed Reference #1** for further information on this setting.

This parameter sets **RR Torque Reference Setpoint #2** and is the output torque value that is associated with setting of **RR Speed Reference #2** while operating in the **Torque** control mode.

Direct Access Number — F215

Parameter Type — **Numerical**

Factory Default — **100.00**

Changeable During Run — **Yes**

Minimum — 0.00

Maximum — 250.0

Units — %

RX Speed Reference #1

Program ⇒ Frequency Setting Parameters ⇒ Speed Reference Setpoints ⇒ **RX**

This parameter is used to set the gain and bias of the **RX** input terminal when the **RX** terminal is used as the control input while operating in the **Speed Control** mode or the **Torque Control** mode.

RX Input Speed Control Setup

Perform the following setup to allow the system to receive **Speed** control input at the **RX** input terminal:

- Program ⇒ Fundamental Parameters ⇒ Standard Mode Selection ⇒ Frequency Mode 1 ⇒ **RX**.
- Program ⇒ Fundamental Parameters ⇒ Standard Mode Selection ⇒ Command Mode ⇒ **Use Control Terminal Strip**.
- Set **RX Speed Reference #1 (F216)** — the input signal level that represents **RX Speed Frequency #1**.
- Set **RX Speed Frequency #1 (F217)**.
- Set **RX Speed Reference #2 (F218)** — the input signal level that represents **RX Speed Frequency #2**.
- Set **RX Speed Frequency #2 (F219)**.
- Provide a **Run** command (**F** and/or **R**).

Once set, as the **RX** input changes, the output frequency of the ASD will vary in accordance with the above settings.

This parameter sets **RX Speed Reference #1** and is the input signal level that is associated with the setting of **RX Speed Frequency #1** while operating in the **Speed Control** mode.

RX Input Torque Control Setup

Perform the following setup to allow the system to receive **Torque** control input at the **RX** input terminal:

- Program ⇒ Fundamental Parameters ⇒ Standard Mode Selection ⇒ Frequency Mode 1 ⇒ **RX**.
- Program ⇒ Fundamental Parameters ⇒ Standard Mode Selection ⇒ Command Mode ⇒ **Use Control Terminal Strip**.
- Set **RX Speed Reference #1 (F216)** — the input signal level that represents **RX Torque Reference Setpoint #1**.
- Set **RX Torque Reference Setpoint #1 (F220)**.
- Set **RX Speed Reference #2 (F218)** — the input signal level that represents **RX Torque Reference Setpoint #2**.
- Set **RX Torque Reference Setpoint #2 (F221)**.
- Provide a **Run** command (**F** and/or **R**).

Once set, as the **RX** input changes, the output torque of the ASD will vary in accordance with the above settings.

This parameter sets **RX Speed Reference #1** and is the input signal level that is associated with the setting of **RX Torque Reference Setpoint #1** while operating in the **Torque Control** mode.

Direct Access Number — F216

Parameter Type — **Numerical**

Factory Default — **00.0**

Changeable During Run — **Yes**

Minimum — **-100.0**

Maximum — **100.0**

Units — **%**

Frequency Settings

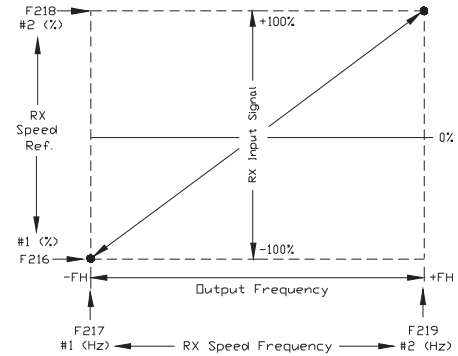

Note: *The speed control response may be further trimmed by adjusting the Bias and Gain settings.*

Torque Settings

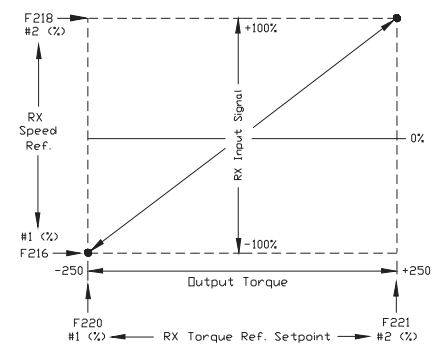

<p>RX Speed Frequency #1</p> <p>Program ⇒ Frequency Setting Parameters ⇒ Speed Reference Setpoints ⇒ RX</p> <p>This parameter is used to set the gain and bias of the RX input terminal when the RX terminal is used as the control input while operating in the Speed Control mode.</p> <p>See RX Speed Reference #1 (F216) for further information on this setting.</p> <p>This parameter sets RX Speed Frequency #1 and is the frequency that is associated with the setting of RX Speed Reference #1 while operating in the Speed Control mode.</p>	<p>Direct Access Number — F217</p> <p>Parameter Type — Numerical</p> <p>Factory Default — 0.0</p> <p>Changeable During Run — Yes</p> <p>Minimum — -Max. Freq. (F011)</p> <p>Maximum — Max. Freq. (F011)</p> <p>Units — Hz</p>
<p>RX Speed Reference #2</p> <p>Program ⇒ Frequency Setting Parameters ⇒ Speed Reference Setpoints ⇒ RX</p> <p>This parameter is used to set the gain and bias of the RX input terminal when the RX terminal is used as the control input while operating in the Speed Control mode or the Torque Control mode.</p> <p>See RX Speed Reference #1 for further information on this setting when used for Speed control or Torque control.</p> <p>This parameter sets the RX input level that is associated with RX Speed Frequency #2 while operating in the Speed control mode or is associated with the RX Torque Reference Setpoint #2 while operating in the Torque control mode.</p>	<p>Direct Access Number — F218</p> <p>Parameter Type — Numerical</p> <p>Factory Default — 100.00</p> <p>Changeable During Run — Yes</p> <p>Minimum — -100.0</p> <p>Maximum — 100.0</p> <p>Units — %</p>
<p>RX Speed Frequency #2</p> <p>Program ⇒ Frequency Setting Parameters ⇒ Speed Reference Setpoints ⇒ RX</p> <p>This parameter is used to set the gain and bias of the RX input terminal when the RX terminal is used as the control input while operating in the Speed Control mode.</p> <p>See RX Speed Reference #1 for further information on this setting when used for Speed control.</p> <p>This parameter sets RX Speed Frequency #2 and is the frequency that is associated with the setting of RX Speed Reference #2 while operating in the Speed Control mode.</p>	<p>Direct Access Number — F219</p> <p>Parameter Type — Numerical</p> <p>Factory Default — 80.00</p> <p>Changeable During Run — Yes</p> <p>Minimum — -Max. Freq. (F011)</p> <p>Maximum — Max. Freq. (F011)</p> <p>Units — Hz</p>
<p>RX Torque Reference Setpoint #1</p> <p>Program ⇒ Torque Setting Parameters ⇒ Setpoints ⇒ RX</p> <p>This parameter is used to set the gain and bias of the RX input terminal when the RX terminal is used as the control input while operating in the Torque Control mode.</p> <p>This is accomplished by establishing an associated V/f output pattern for a given RX input level.</p> <p>See RX Speed Reference #1 for further information on this setting.</p> <p>This parameter sets RX Torque Reference Setpoint #1 and is the output torque value that is associated with the setting of RX Speed Reference #1 while operating in the Torque control mode.</p>	<p>Direct Access Number — F220</p> <p>Parameter Type — Numerical</p> <p>Factory Default — 0.00</p> <p>Changeable During Run — Yes</p> <p>Minimum — -250.00</p> <p>Maximum — 250.00</p> <p>Units — %</p>

RX Torque Reference Setpoint #2

Program ⇒ Torque Setting Parameters ⇒ Setpoints ⇒ **RX**

This parameter is used to set the gain and bias of the **RX** input terminal when the **RX** terminal is used as the control input while operating in the **Torque Control** mode.

This is accomplished by establishing an associated **V/f** output pattern for a given **RX** input level.

See **RX Speed Reference #1** for further information on this setting.

This parameter sets **RX Torque Reference Setpoint #2** and is the output torque value that is associated with setting of **RX Speed Reference #2** while operating in the **Torque** control mode.

Direct Access Number — F221

Parameter Type — **Numerical**

Factory Default — **100.00**

Changeable During Run — **Yes**

Minimum — -250.00

Maximum — 250.00

Units — %

RX2 Speed Reference #1

Program ⇒ Frequency Setting Parameters ⇒ Speed Reference Setpoints ⇒ **RX2**

This parameter is used to set the gain and bias of the **RX2** input terminal when the **RX2** terminal is used as the control input while operating in the **Speed Control** mode or the **Torque Control** mode.

RX2 Input Speed Control Setup

Perform the following setup to allow the system to receive **Speed** control input at the **RX2** input terminal:

- Program ⇒ Fundamental Parameters ⇒ Standard Mode Selection ⇒ Frequency Mode 1 ⇒ **RX2**.
- Program ⇒ Fundamental Parameters ⇒ Standard Mode Selection ⇒ Command Mode ⇒ **Use Control Terminal Strip**.
- Set **RX2 Speed Reference #1 (F222)** — the input signal level that represents **RX2 Speed Frequency #1**.
- Set **RX2 Speed Frequency #1 (F223)**.
- Set **RX2 Speed Reference #2 (F224)** — the input signal level that represents **RX2 Speed Frequency #2**.
- Set **RX2 Speed Frequency #2 (F225)**.
- Provide a **Run** command (**F** and/or **R**).

Once set, as the **RX2** input changes, the output frequency of the ASD will vary in accordance with the above settings.

This parameter sets **RX2 Speed Reference #1** and is the input signal level that is associated with the setting of **RX2 Speed Frequency #1** while operating in the **Speed Control** mode.

RX2 Input Torque Control Setup

Perform the following setup to allow the system to receive **Torque** control input at the **RX2** input terminal:

- Program ⇒ Fundamental Parameters ⇒ Standard Mode Selection ⇒ Frequency Mode 1 ⇒ **RX2**.
- Program ⇒ Fundamental Parameters ⇒ Standard Mode Selection ⇒ Command Mode ⇒ **Use Control Terminal Strip**.
- Set **RX2 Speed Reference #1 (F222)** — the input signal level that represents **RX2 Torque Reference Setpoint #1**.
- Set **RX2 Torque Reference Setpoint #1 (F226)**.
- Set **RX2 Speed Reference #2 (F224)** — the input signal level that represents **RX2 Torque Reference Setpoint #2**.
- Set **RX2 Torque Reference Setpoint #2 (F227)**.
- Provide a **Run** command (**F** and/or **R**).

Once set, as the **RX2** input changes, the output torque of the ASD will vary in accordance with the above settings.

This parameter sets **RX2 Speed Reference #1** and is the input signal level that is associated with the setting of **RX2 Torque Reference Setpoint #1** while operating in the **Torque Control** mode.

Direct Access Number — F222

Parameter Type — **Numerical**

Factory Default — **00.0**

Changeable During Run — **Yes**

Minimum — -100.0

Maximum — 100.0

Units — %

Frequency Settings

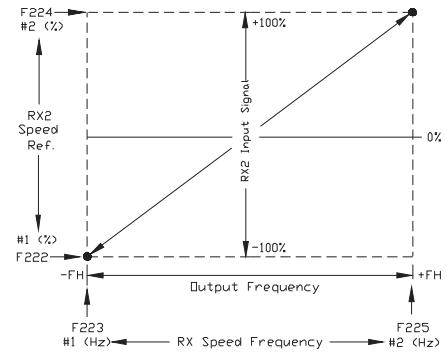

Note: *The speed control response may be further trimmed by adjusting the Bias and Gain settings.*

Torque Settings

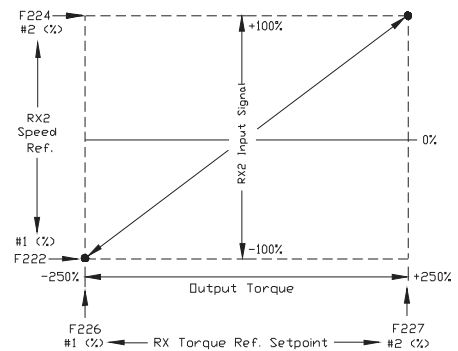

<p>RX2 Speed Frequency #1</p> <p>Program ⇒ Frequency Setting Parameters ⇒ Speed Reference Setpoints ⇒ RX2</p> <p>This parameter is used to set the gain and bias of the RX2 input terminal when the RX2 terminal is used as the control input while operating in the Speed Control mode.</p> <p>See RX2 Speed Reference #1 (F222) for further information on this setting.</p> <p>This parameter sets RX2 Speed Frequency #1 and is the frequency that is associated with the setting of RX2 Speed Reference #1 while operating in the Speed Control mode.</p>	<p>Direct Access Number — F223</p> <p>Parameter Type — Numerical</p> <p>Factory Default — 0.0</p> <p>Changeable During Run — Yes</p> <p>Minimum — -Max. Freq. (F011)</p> <p>Maximum — Max. Freq. (F011)</p> <p>Units — Hz</p>
<p>RX2 Speed Reference #2</p> <p>Program ⇒ Frequency Setting Parameters ⇒ Speed Reference Setpoints ⇒ RX2</p> <p>This parameter is used to set the gain and bias of the RX2 input terminal when the RX2 terminal is used as the control input while operating in the Speed Control mode or the Torque Control mode.</p> <p>See RX2 Speed Reference #1 for further information on this setting when used for Speed control or Torque control.</p> <p>This parameter sets the RX2 input level that is associated with RX2 Speed Frequency #2 while operating in the Speed control mode or is associated with the RX2 Torque Reference Setpoint #2 while operating in the Torque control mode.</p>	<p>Direct Access Number — F224</p> <p>Parameter Type — Numerical</p> <p>Factory Default — 100.00</p> <p>Changeable During Run — Yes</p> <p>Minimum — -100.0</p> <p>Maximum — 100.0</p> <p>Units — %</p>
<p>RX2 Speed Frequency #2</p> <p>Program ⇒ Frequency Setting Parameters ⇒ Speed Reference Setpoints ⇒ RX2</p> <p>This parameter is used to set the gain and bias of the RX2 input terminal when the RX2 terminal is used as the control input while operating in the Speed Control mode.</p> <p>See RX2 Speed Reference #1 for further information on this setting when used for Speed control.</p> <p>This parameter sets RX2 Speed Frequency #2 and is the frequency that is associated with the setting of RX2 Speed Reference #2 while operating in the Speed Control mode.</p>	<p>Direct Access Number — F225</p> <p>Parameter Type — Numerical</p> <p>Factory Default — 80.00</p> <p>Changeable During Run — Yes</p> <p>Minimum — -Max. Freq. (F011)</p> <p>Maximum — Max. Freq. (F011)</p> <p>Units — Hz</p>
<p>RX2 Torque Reference Setpoint #1</p> <p>Program ⇒ Torque Setting Parameters ⇒ Setpoints ⇒ RX2</p> <p>This parameter is used to set the gain and bias of the RX2 input terminal when the RX2 terminal is used as the control input while operating in the Torque Control mode.</p> <p>This is accomplished by establishing an associated V/f output pattern for a given RX2 input level.</p> <p>See RX2 Speed Reference #1 for further information on this setting.</p> <p>This parameter sets RX2 Torque Reference Setpoint #1 and is the output torque value that is associated with the setting of RX2 Speed Reference #1 while operating in the Torque control mode.</p>	<p>Direct Access Number — F226</p> <p>Parameter Type — Numerical</p> <p>Factory Default — 0.00</p> <p>Changeable During Run — Yes</p> <p>Minimum — -250.00</p> <p>Maximum — 250.00</p> <p>Units — %</p>

RX2 Torque Reference Setpoint #2

Program ⇒ Torque Setting Parameters ⇒ Setpoints ⇒ **RX2**

This parameter is used to set the gain and bias of the **RX2** input terminal when the **RX2** terminal is used as the control input while operating in the **Torque Control** mode.

This is accomplished by establishing an associated **V/f** output pattern for a given **RX2** input level.

See **RX2 Speed Reference #1** for further information on this setting.

This parameter sets **RX2 Torque Reference Setpoint #2** and is the output torque value that is associated with setting of **RX2 Speed Reference #2** while operating in the **Torque** control mode.

Direct Access Number — F227

Parameter Type — Numerical

Factory Default — 100.00

Changeable During Run — Yes

Minimum — -250.00

Maximum — 250.00

Units — %

BIN Speed Reference #1

Program ⇒ Frequency Setting Parameters ⇒ Speed Reference Setpoints ⇒ **BIN**

This parameter is used to set the gain and bias of the binary input when the discrete input terminals are used as the control input while operating in the **Speed Control** mode or the **Torque Control** mode.

BIN Input Control Setup

Perform the following setup to allow the system to receive control input at the binary input terminals:

- Program ⇒ Fundamental Parameters ⇒ Standard Mode Selection ⇒ Frequency Mode 1 ⇒ **Use Binary/BCD Input**.
- Program ⇒ Fundamental Parameters ⇒ Standard Mode Selection ⇒ Command Mode ⇒ **Use Control Terminal Strip**.
- Program ⇒ Terminal Selection Parameters ⇒ **Input Terminals**; select and set the desired discrete input terminals to **Binary Bit(s) 0 – 7** (or 0 – MSB) (see [Table 5 on pg. 162](#)). The binary input can control the direction, speed, and/or torque of the motor.

Note: 255_D is the decimal equivalent of the 8-bit BIN word with all input terminals set to one (255 decimal = 11111111 binary).

BIN Speed Control Setup

- Set **BIN Speed Reference #1 (F228)** — the input signal that represents **BIN Speed Frequency #1**.
- Set **BIN Speed Frequency #1 (F229)**.
- Set **BIN Speed Reference #2 (F230)** — the input signal that represents **BIN Speed Frequency #2**.
- Set **BIN Speed Frequency #2 (F231)**.
- Provide a **Run** command (**F** and/or **R**).

Once set, as the binary input signal changes, the output signal of the ASD will vary in accordance with the above settings.

This parameter sets **BIN Speed Reference #1** and is the input signal that is associated with the setting of **BIN Speed Frequency #1** while operating in the **Speed Control** mode.

BIN Torque Control Setup

- Set **BIN Speed Reference #1 (F228)** — the input signal level that represents **BIN Torque Reference Setpoint #1**.
- Set **BIN Torque Reference Setpoint #1 (F232)**.
- Set **BIN Speed Reference #2 (F230)** — the input signal level that represents **BIN Torque Reference Setpoint #2**.
- Set **BIN Torque Reference Setpoint #2 (F233)**.
- Provide a **Run** command (**F** and/or **R**).

Once set, as the binary input signal changes, the output signal of the ASD will vary in accordance with the above settings.

This parameter sets **BIN Speed Reference #1** and is the input signal that is associated with the setting of **BIN Torque Reference Setpoint #1** while operating in the **Torque Control** mode.

Direct Access Number — F228

Parameter Type — **Numerical**

Factory Default — **0.00**

Changeable During Run — **Yes**

Minimum — 0.0

Maximum — 100.0

Units — %

Frequency Settings

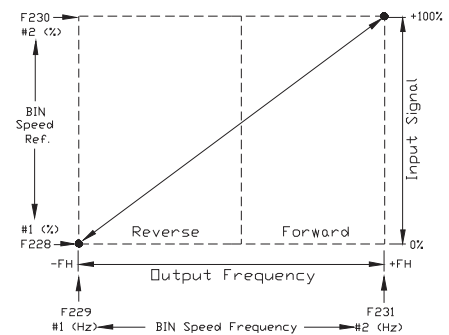

Torque Settings

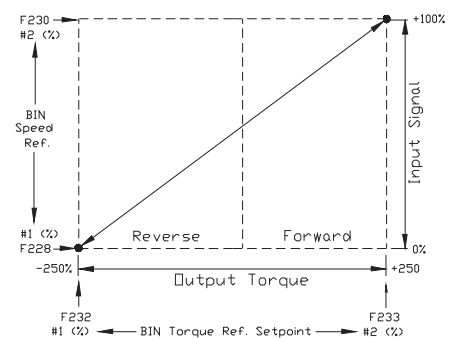

<p>BIN Speed Frequency #1</p> <p>Program ⇒ Frequency Setting Parameters ⇒ Speed Reference Setpoints ⇒ BIN</p> <p>This parameter is used to set the gain and bias of the binary input when the discrete input terminals are used as the control input while operating in the Speed Control mode.</p> <p>This parameter sets BIN Speed Frequency #1 and is the frequency that is associated with the setting of BIN Speed Reference #1 while operating in the Speed Control mode.</p> <p>See BIN Speed Reference #1 (F228) for further information on this setting.</p>	<p>Direct Access Number — F229</p> <p>Parameter Type — Numerical</p> <p>Factory Default — 0.0</p> <p>Changeable During Run — Yes</p> <p>Minimum — -Max. Freq. (F011)</p> <p>Maximum — Max. Freq. (F011)</p> <p>Units — Hz</p>
<p>BIN Speed Reference #2</p> <p>Program ⇒ Frequency Setting Parameters ⇒ Speed Reference Setpoints ⇒ BIN</p> <p>This parameter is used to set the gain and bias of the binary input when the discrete input terminals are used as the control input while operating in the Speed Control mode or the Torque Control mode.</p> <p>See BIN Speed Reference #1 for further information on this setting when used for Speed control or Torque control.</p> <p>This parameter sets BIN Speed Reference #2 and is the input signal that is associated with the setting of BIN Speed Frequency #1 while operating in the Speed Control mode or is associated with the BIN Torque Reference Setpoint #2 while operating in the Torque control mode.</p>	<p>Direct Access Number — F230</p> <p>Parameter Type — Numerical</p> <p>Factory Default — 100.00</p> <p>Changeable During Run — Yes</p> <p>Minimum — 0.0</p> <p>Maximum — 100.0</p> <p>Units — %</p>
<p>BIN Speed Frequency #2</p> <p>Program ⇒ Frequency Setting Parameters ⇒ Speed Reference Setpoints ⇒ BIN</p> <p>This parameter is used to set the gain and bias of the binary input when the discrete input terminals are used as the control input while operating in the Speed Control mode.</p> <p>This parameter sets BIN Speed Frequency #2 and is the frequency that is associated with the setting of BIN Speed Reference #1 while operating in the Speed Control mode.</p> <p>See BIN Speed Reference #1 (F228) for further information on this setting.</p>	<p>Direct Access Number — F231</p> <p>Parameter Type — Numerical</p> <p>Factory Default — 80.00</p> <p>Changeable During Run — Yes</p> <p>Minimum — -Max. Freq. (F011)</p> <p>Maximum — Max. Freq. (F011)</p> <p>Units — Hz</p>
<p>BIN Torque Reference Setpoint #1</p> <p>Program ⇒ Torque Setting Parameters ⇒ Setpoints ⇒ BIN</p> <p>This parameter is used to set the gain and bias of the binary input when the discrete input terminals are used as the control input while operating in the Torque Control mode.</p> <p>This is accomplished by establishing an associated V/f output pattern for a given binary input signal.</p> <p>See BIN Speed Reference #1 for further information on this setting.</p> <p>This parameter sets BIN Torque Reference Setpoint #1 and is the output torque value that is associated with the setting of BIN Speed Reference #1 while operating in the Torque control mode.</p>	<p>Direct Access Number — F232</p> <p>Parameter Type — Numerical</p> <p>Factory Default — 0.00</p> <p>Changeable During Run — Yes</p> <p>Minimum — -250.0</p> <p>Maximum — 250.0</p> <p>Units — %</p>

BIN Torque Reference Setpoint #2

Program ⇒ Torque Setting Parameters ⇒ Setpoints ⇒ **BIN**

This parameter is used to set the gain and bias of the binary input when the discrete input terminals are used as the control input while operating in the **Torque Control** mode.

This is accomplished by establishing an associated **V/f** output pattern for a given binary input signal.

See **BIN Speed Reference #1** for further information on this setting.

This parameter sets **BIN Torque Reference Setpoint #2** and is the output torque value that is associated with setting of **BIN Speed Reference #2** while operating in the **Torque** control mode.

Direct Access Number — F233

Parameter Type — **Numerical**

Factory Default — **100.00**

Changeable During Run — **Yes**

Minimum — -250.0

Maximum — 250.0

Units — %

PG Speed Reference #1

Program ⇒ Frequency Setting Parameters ⇒ Speed Reference Setpoints ⇒ **PG**

This parameter is used to set the gain and bias of the **PG** input terminal when a shaft-mounted encoder is used as the feedback transducer while operating in the **Speed Control** mode.

Note: The **ASD — Multicom Option Board** and the **HS35 Encoder** is required for system operation using the **PG** input speed control.

Direct Access Number — F234

Parameter Type — **Numerical**

Factory Default — **0.00**

Changeable During Run — **Yes**

Minimum — -100.0

Maximum — 100.0

Units — %

PG Input Speed Control Setup

Perform the following setup to allow the system to receive **Speed** control input at the **PG** input terminal:

- Program ⇒ Fundamental Parameters ⇒ Standard Mode Selection ⇒ Frequency Mode 1 ⇒ **Pulse Input Option**.
- Program ⇒ Fundamental Parameters ⇒ Standard Mode Selection ⇒ Command Mode ⇒ (any setting).
- Set **PG Speed Reference #1 (F234)** — the input pulse count rate that represents **PG Speed Frequency #1**.
- Set **PG Speed Frequency #1 (F235)**.
- Set **PG Speed Reference #2 (F236)** — the input pulse count rate that represents **PG Speed Frequency #2**.
- Set **PG Speed Frequency #2 (F237)**.
- Provide a **Run** command (**F** and/or **R**).

Once set, as the **PG** pulse count rate changes, the output frequency of the ASD will vary in accordance with the above settings.

This parameter sets **PG Speed Reference #1** and is the input pulse count rate that is associated with the setting of **PG Speed Frequency #1** while operating in the **Speed Control** mode.

Frequency Settings

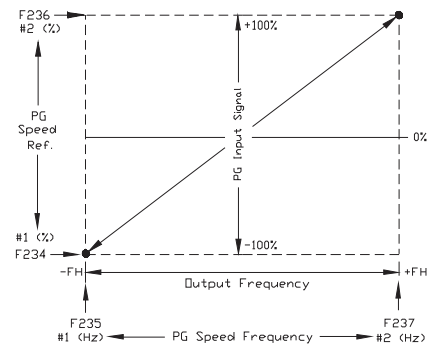

<p>PG Speed Frequency #1</p> <p>Program ⇒ Frequency Setting Parameters ⇒ Speed Reference Setpoints ⇒ PG</p> <p>This parameter is used to set the gain and bias of the PG input terminal when a shaft-mounted encoder is used as the feedback transducer while operating in the Speed Control mode.</p> <p>See PG Speed Reference #1 (F234) for further information on this setting.</p> <p>This parameter sets PG Speed Frequency #1 and is the frequency that is associated with the setting of PG Speed Reference #1 while operating in the Speed Control mode.</p>	<p>Direct Access Number — F235</p> <p>Parameter Type — Numerical</p> <p>Factory Default — 0.00</p> <p>Changeable During Run — Yes</p> <p>Minimum — -Max. Freq. (F011)</p> <p>Maximum — Max. Freq. (F011)</p> <p>Units — Hz</p>
<p>PG Speed Reference #2</p> <p>Program ⇒ Frequency Setting Parameters ⇒ Speed Reference Setpoints ⇒ PG</p> <p>This parameter is used to set the gain and bias of the PG input terminal when a shaft-mounted encoder is used as the feedback transducer while operating in the Speed Control mode.</p> <p>See PG Speed Reference #1 for further information on this setting when used for Speed control.</p> <p>This parameter sets the PG input level that is associated with PG Speed Frequency #2 while operating in the Speed control mode.</p>	<p>Direct Access Number — F236</p> <p>Parameter Type — Numerical</p> <p>Factory Default — 100.00</p> <p>Changeable During Run — Yes</p> <p>Minimum — -100.0</p> <p>Maximum — 100.0</p> <p>Units — %</p>
<p>PG Speed Frequency #2</p> <p>Program ⇒ Frequency Setting Parameters ⇒ Speed Reference Setpoints ⇒ PG</p> <p>This parameter is used to set the gain and bias of the PG input terminal when a shaft-mounted encoder is used as the feedback transducer while operating in the Speed Control mode.</p> <p>See PG Speed Reference #1 for further information on this setting when used for Speed control.</p> <p>This parameter sets PG Speed Frequency #2 and is the frequency that is associated with the setting of PG Speed Reference #2 while operating in the Speed Control mode.</p>	<p>Direct Access Number — F237</p> <p>Parameter Type — Numerical</p> <p>Factory Default — 80.00</p> <p>Changeable During Run — Yes</p> <p>Minimum — -Max. Freq. (F011)</p> <p>Maximum — Max. Freq. (F011)</p> <p>Units — Hz</p>
<p>Startup Frequency</p> <p>Program ⇒ Special Control Parameters ⇒ Frequency Control</p> <p>The output of the drive will remain at 0.0 Hz until the programmed speed value exceeds this setting during startup. Once exceeded during startup, the output frequency of the drive will accelerate to the programmed setting.</p> <p>Output frequencies below the Startup Frequency will not be output from the drive during startup. However, once reaching the Startup Frequency, speed values below the Startup Frequency may be output from the drive.</p>	<p>Direct Access Number — F240</p> <p>Parameter Type — Numerical</p> <p>Factory Default — 0.10</p> <p>Changeable During Run — Yes</p> <p>Minimum — 0.0</p> <p>Maximum — 10.0</p> <p>Units — Hz</p>

<p>Run Frequency</p> <p>Program ⇒ Special Control Parameters ⇒ Frequency Control</p> <p>This parameter establishes a center frequency (Run Frequency) of a frequency band.</p> <p>Parameter F242 provides a plus-or-minus value for the Run Frequency; thus, establishing a frequency band.</p> <p>During acceleration, the drive will not output a signal to the motor until the lower level of the band is reached.</p> <p>During deceleration, the drive will continue to output the programmed deceleration output signal to the motor until the lower level of the band is reached; at which time the output will go to 0.0 Hz.</p>	<p>Direct Access Number — F241</p> <p>Parameter Type — Numerical</p> <p>Factory Default — 0.0</p> <p>Changeable During Run — Yes</p> <p>Minimum — 0.0</p> <p>Maximum — Max. Freq. (F011)</p> <p>Units — Hz</p>
<p>Run Frequency Hysteresis</p> <p>Program ⇒ Special Control Parameters ⇒ Frequency Control</p> <p>This parameter provides a plus-or-minus value for the Run Frequency setting (F241).</p>	<p>Direct Access Number — F242</p> <p>Parameter Type — Numerical</p> <p>Factory Default — 0.0</p> <p>Changeable During Run — Yes</p> <p>Minimum — 0.0</p> <p>Maximum — 30.0</p> <p>Units — Hz</p>
<p>End Frequency</p> <p>Program ⇒ Special Control Parameters ⇒ Frequency Control</p> <p>This parameter sets the lowest frequency that the drive will recognize during deceleration before the drive goes to 0.0 Hz.</p>	<p>Direct Access Number — F243</p> <p>Parameter Type — Numerical</p> <p>Factory Default — 0.0</p> <p>Changeable During Run — Yes</p> <p>Minimum — 0.0</p> <p>Maximum — 30.0</p> <p>Units — Hz</p>
<p>0 Hz Dead Band Signal</p> <p>Program ⇒ Special Control Parameters ⇒ Special Parameters ⇒ Dead Band of 0 Hz Frequency</p> <p>This parameter sets an output frequency threshold that, until the commanded frequency surpasses this setting, the ASD will output 0 Hz to the motor.</p> <p><i>Note: This setting will override the Startup Frequency setting (F240) if this setting has a higher value.</i></p>	<p>Direct Access Number — F244</p> <p>Parameter Type — Numerical</p> <p>Factory Default — 0.0</p> <p>Changeable During Run — Yes</p> <p>Minimum — 0.0</p> <p>Maximum — 5.0</p> <p>Units — Hz</p>

DC Injection Braking Start FrequencyProgram ⇒ Protection Parameters ⇒ **DC Braking**

During deceleration this is the frequency at which **DC Injection** braking will start.

DC Injection Braking

DC Injection Braking is a braking system used with three-phase motors. Unlike conventional brakes, there is no physical contact between the rotating shaft and a stationary brake pad or drum. When braking is required, the drive outputs a DC current that is applied to the windings of the motor to quickly brake the motor. The braking current stops when the time entered in **F252** times out.

The intensity of the DC current used while braking determines how fast the motor will come to a stop and may be set at **F251**. The intensity setting is entered as a percentage of the full load current of the ASD.

DC Injection Braking is also used to preheat the motor or to keep the rotor from spinning freely when the motor is off by providing a pulsating DC current into the motor at the **Carrier Frequency**. This feature may be enabled at **F254**.

DC Injection Braking CurrentProgram ⇒ Protection Parameters ⇒ **DC Braking**

This parameter sets the percentage of the rated current of the drive that will be used for **DC Injection** braking. A larger load will require a higher setting.

DC Injection Braking TimeProgram ⇒ Protection Parameters ⇒ **DC Braking**

This parameter is used to set the on-time duration of the DC Injection Braking.

Motor Shaft Fixing ControlProgram ⇒ Protection Parameters ⇒ **DC Braking**

This parameter determines if **DC Injection** braking is to be used during a change in the direction of the motor.

Settings:

- Box checked (Enabled)
- Box not checked (Disabled)

Direct Access Number — F250Parameter Type — **Numerical**Factory Default — **0.0**Changeable During Run — **Yes**

Minimum — 0.0

Maximum — 120.0

Units — Hz

Direct Access Number — F251Parameter Type — **Numerical**Factory Default — **50.00**Changeable During Run — **Yes**

Minimum — 0.00

Maximum — 100.0

Units — %

Direct Access Number — F252Parameter Type — **Numerical**Factory Default — **1.00**Changeable During Run — **Yes**

Minimum — 0.00

Maximum — 10.00

Units — Seconds

Direct Access Number — F253Parameter Type — **Check Box**Factory Default — **Disabled**Changeable During Run — **Yes**

Motor Shaft Stationary ControlProgram ⇒ Protection Parameters ⇒ **DC Braking**

This parameter **Enables/Disables** a continuous DC injection at half of the amperage setting of **F251** into a stopped motor. This feature is useful in preheating the motor or to keep the rotor from spinning freely.

Motor Shaft Stationary Control starts after the DC injection brake stops the motor and continues until **ST – CC** is opened, power is turned off, receiving an **Emergency Off** command, or this parameter is changed.

Enabling this feature will also require a non-zero entry at **F250**.

Settings:

Box checked (Enabled)

Box not checked (Disabled)

Direct Access Number — F254Parameter Type — **Check Box**Factory Default — **Disabled**Changeable During Run — **Yes**

0 Hz Command FunctionProgram ⇒ Special Control Parameters ⇒ Special Parameters ⇒ **Dead Band of 0 Hz Frequency**

This parameter selects the go-to-zero method to be used by the ASD when the ASD is commanded to go to zero Hz.

Settings:

Standard (DC Injection Braking)

0 Hz Command

Direct Access Number — F255Parameter Type — **Selection List**Factory Default — **Standard (DC Injection Braking)**Changeable During Run — **No**

Jog Run Frequency

Program ⇒ Frequency Setting Parameters ⇒ **Jog Settings**

This parameter sets the output frequency of the drive during a **Jog**. **Jogging** is the term used to describe turning the motor on for small increments of time and is used when precise positioning of motor-driven equipment is required.

Enabling the **Jog Window** allows for the **Manual Jog** window to be among the screens accessed during repeated **MON/PRG** entries. This screen must be displayed when **Jogging** using the **EOI**.

The **Jog** function may be initiated from the **EOI** or remotely via the **Control Terminal Strip** or using **Communications** (for further information on using **Communications** for **Jogging**, see the **Communications** manual).

To perform a **Jog**, set this parameter (**F260**) to the desired **Jog** frequency.

Select a **Jog Stop** method (**F261**).

Jog Setup Using the EOI

To initiate a **Jog** from the **EOI** perform the following:

1. Place a check in the **Enable Jog Window** box (Program ⇒ Frequency Setting Parameters ⇒ Jog Settings ⇒ **Enable Jog Window**).

Note: The Jog Window must be displayed on the EOI to perform the Jog function using the EOI.

2. Press **MON/PRG** to access the **Jog Window**.
3. Using the **Up/Down** arrow keys of the **EOI**, select **Reverse** or **Forward**.
4. Place the system in the **Local** mode (**Local/Remote** LED is on).
5. Press and hold the **Run** key for the desired **Jog** duration.

Jog Setup Using the Control Terminal Strip

To initiate a **Jog** from the **Control Terminal Strip** perform the following:

1. Assign a discrete input terminal to the **Jog** function (see [Table 5 on pg. 162](#)).
2. Assign a discrete input terminal to the **F (Forward)** function (and **Reverse** if required) (see [Table 5 on pg. 162](#)).
3. Provide a **Forward** and/or **Reverse** command from the **Control Terminal Strip**.
4. From the **Jog Window**, use the **Up/Down** arrow keys of the **EOI** to select **Reverse** or **Forward** (Program ⇒ Frequency Setting Parameters ⇒ Jog Settings ⇒ **Enable Jog Window**). Press **MON/PRG** to access the **Jog Window**.
5. Place the system in the **Remote** mode (**Local/Remote** LED is off).
6. Connect the assigned **Jog** terminal (from step 1) to **CC** for the desired **Jog** duration.

Direct Access Number — F260

Parameter Type — **Numerical**

Factory Default — **0.00**

Changeable During Run — **Yes**

Minimum — 0.00

Maximum — 20.00

Units — Hz

<p>Jog Stop Control</p> <p>Program ⇒ Frequency Setting Parameters ⇒ Jog Settings</p> <p>This parameter sets the stopping method used while operating in the Jog mode.</p> <p>Settings:</p> <ul style="list-style-type: none"> Deceleration Stop Coast Stop DC Injection Braking Stop 	<p>Direct Access Number — F261</p> <p>Parameter Type — Selection List</p> <p>Factory Default — Deceleration Stop</p> <p>Changeable During Run — Yes</p>
<p>Jump Frequency #1</p> <p>Program ⇒ Special Control Parameters ⇒ Jump Frequencies</p> <p>In conjunction with parameter F271, this parameter establishes a user-defined frequency range: the Jump Frequency and a plus-or-minus value. During acceleration, the output frequency of the drive will hold at the frequency of the lower level of the Jump Frequency range until the programmed acceleration ramp reaches the upper level of the Jump Frequency range. Then, the output frequency of the drive will accelerate to the upper level of the Jump Frequency range and continue upward as programmed.</p> <p>During deceleration, the output frequency of the drive will hold at the frequency of the upper level of the Jump Frequency range until the programmed deceleration ramp reaches the lower level of the Jump Frequency range. Then, the output frequency of the drive will decelerate to the lower level of the Jump Frequency range and continue downward as programmed.</p> <p>Once set up and enabled, it is on in all control modes.</p> <p>User-selected frequencies may be jumped to avoid the negative effects of mechanical resonance.</p>	<p>Direct Access Number — F270</p> <p>Parameter Type — Numerical</p> <p>Factory Default — 0.00</p> <p>Changeable During Run — Yes</p> <p>Minimum — 0.00</p> <p>Maximum — Max. Freq. (F011)</p> <p>Units — Hz</p>
<p>Jump Frequency #1 Bandwidth</p> <p>Program ⇒ Special Control Parameters ⇒ Jump Frequencies</p> <p>This parameter establishes a plus-or-minus value for Jump Frequency #1 (see F270).</p>	<p>Direct Access Number — F271</p> <p>Parameter Type — Numerical</p> <p>Factory Default — 0.00</p> <p>Changeable During Run — Yes</p> <p>Minimum — 0.00</p> <p>Maximum — 30.00</p> <p>Units — Hz</p>
<p>Jump Frequency #2</p> <p>Program ⇒ Special Control Parameters ⇒ Jump Frequencies</p> <p>Same as Jump Frequency #1 (F270) and is used when multiple frequencies are to be jumped (see the plus-or-minus value setting at F273). When multiple jump frequencies overlap, the system will recognize the lowest and the highest frequencies as one jump range.</p>	<p>Direct Access Number — F272</p> <p>Parameter Type — Numerical</p> <p>Factory Default — 0.00</p> <p>Changeable During Run — Yes</p> <p>Minimum — 0.00</p> <p>Maximum — Max. Freq. (F011)</p> <p>Units — Hz</p>
<p>Jump Frequency #2 Bandwidth</p> <p>Program ⇒ Special Control Parameters ⇒ Jump Frequencies</p> <p>This parameter establishes a plus-or-minus value for Jump Frequency #2 (F272).</p>	<p>Direct Access Number — F273</p> <p>Parameter Type — Numerical</p> <p>Factory Default — 0.00</p> <p>Changeable During Run — Yes</p> <p>Minimum — 0.00</p> <p>Maximum — 30.0</p> <p>Units — Hz</p>

<p>Jump Frequency #3</p> <p>Program ⇒ Special Control Parameters ⇒ Jump Frequencies</p> <p>Same as Jump Frequency #1 (F270) and is used when multiple frequencies are to be jumped (see the plus-or-minus value setting at F275). When multiple jump frequencies overlap, the system will recognize the lowest and the highest frequencies as one jump range.</p>	<p>Direct Access Number — F274</p> <p>Parameter Type — Numerical</p> <p>Factory Default — 0.00</p> <p>Changeable During Run — Yes</p> <p>Minimum — 0.00</p> <p>Maximum — Max. Freq. (F011)</p> <p>Units — Hz</p>
<p>Jump Frequency #3 Bandwidth</p> <p>Program ⇒ Special Control Parameters ⇒ Jump Frequencies</p> <p>This parameter establishes a plus-or-minus value for Jump Frequency #3 (F274).</p>	<p>Direct Access Number — F275</p> <p>Parameter Type — Numerical</p> <p>Factory Default — 0.00</p> <p>Changeable During Run — Yes</p> <p>Minimum — 0.00</p> <p>Maximum — 30.0</p> <p>Units — Hz</p>
<p>Jump Frequency Processing</p> <p>Program ⇒ Special Control Parameters ⇒ Jump Frequencies ⇒ Jump Frequency Processing</p> <p>This parameter determines if the output frequency of the ASD or the PID feedback signal will be used as a reference for determining the Jump Frequency range.</p> <p>See F270 for further information on the Jump Frequency settings.</p> <p>Settings:</p> <ul style="list-style-type: none"> Process Amount (use PID feedback) Output Frequency 	<p>Direct Access Number — F276</p> <p>Parameter Type — Selection List</p> <p>Factory Default — Process Amount</p> <p>Changeable During Run — Yes</p>
<p>Preset Speed #8</p> <p>Program ⇒ Pattern Run Control ⇒ Preset Speeds ⇒ 8</p> <p>This parameter assigns an output frequency to binary number 1000 and is identified as Preset Speed #8. The binary number is applied to S1 – S4 of the Control Terminal Strip to output the Preset Speed (see F018 for further information on this parameter).</p>	<p>Direct Access Number — F287</p> <p>Parameter Type — Numerical</p> <p>Factory Default — 0.00</p> <p>Changeable During Run — Yes</p> <p>Minimum — Lower Limit (F013)</p> <p>Maximum — Upper Limit (F012)</p> <p>Units — Hz</p>
<p>Preset Speed #9</p> <p>Program ⇒ Pattern Run Control ⇒ Preset Speeds ⇒ 9</p> <p>This parameter assigns an output frequency to binary number 1001 and is identified as Preset Speed #9. The binary number is applied to S1 – S4 of the Control Terminal Strip to output the Preset Speed (see F018 for further information on this parameter).</p>	<p>Direct Access Number — F288</p> <p>Parameter Type — Numerical</p> <p>Factory Default — 0.0</p> <p>Changeable During Run — Yes</p> <p>Minimum — Lower Limit (F013)</p> <p>Maximum — Upper Limit (F012)</p> <p>Units — Hz</p>

<p>Preset Speed #10</p> <p>Program ⇒ Pattern Run Control ⇒ Preset Speeds ⇒ 10</p> <p>This parameter assigns an output frequency to binary number 1010 and is identified as Preset Speed #10. The binary number is applied to S1 – S4 of the Control Terminal Strip to output the Preset Speed (see F018 for further information on this parameter).</p>	<p>Direct Access Number — F289</p> <p>Parameter Type — Numerical</p> <p>Factory Default — 0.00</p> <p>Changeable During Run — Yes</p> <p>Minimum — Lower Limit (F013)</p> <p>Maximum — Upper Limit (F012)</p> <p>Units — Hz</p>
<p>Preset Speed #11</p> <p>Program ⇒ Pattern Run Control ⇒ Preset Speeds ⇒ 11</p> <p>This parameter assigns an output frequency to binary number 1011 and is identified as Preset Speed #11. The binary number is applied to S1 – S4 of the Control Terminal Strip to output the Preset Speed (see F018 for further information on this parameter).</p>	<p>Direct Access Number — F290</p> <p>Parameter Type — Numerical</p> <p>Factory Default — 0.00</p> <p>Changeable During Run — Yes</p> <p>Minimum — Lower Limit (F013)</p> <p>Maximum — Upper Limit (F012)</p> <p>Units — Hz</p>
<p>Preset Speed #12</p> <p>Program ⇒ Pattern Run Control ⇒ Preset Speeds ⇒ 12</p> <p>This parameter assigns an output frequency to binary number 1100 and is identified as Preset Speed #12. The binary number is applied to S1 – S4 of the Control Terminal Strip to output the Preset Speed (see F018 for further information on this parameter).</p>	<p>Direct Access Number — F291</p> <p>Parameter Type — Numerical</p> <p>Factory Default — 0.00</p> <p>Changeable During Run — Yes</p> <p>Minimum — Lower Limit (F013)</p> <p>Maximum — Upper Limit (F012)</p> <p>Units — Hz</p>
<p>Preset Speed #13</p> <p>Program ⇒ Pattern Run Control ⇒ Preset Speeds ⇒ 13</p> <p>This parameter assigns an output frequency to binary number 1101 and is identified as Preset Speed #13. The binary number is applied to S1 – S4 of the Control Terminal Strip to output the Preset Speed (see F018 for further information on this parameter).</p>	<p>Direct Access Number — F292</p> <p>Parameter Type — Numerical</p> <p>Factory Default — 0.00</p> <p>Changeable During Run — Yes</p> <p>Minimum — Lower Limit (F013)</p> <p>Maximum — Upper Limit (F012)</p> <p>Units — Hz</p>
<p>Preset Speed #14</p> <p>Program ⇒ Pattern Run Control ⇒ Preset Speeds ⇒ 14</p> <p>This parameter assigns an output frequency to binary number 1110 and is identified as Preset Speed #14. The binary number is applied to S1 – S4 of the Control Terminal Strip to output the Preset Speed (see F018 for further information on this parameter).</p>	<p>Direct Access Number — F293</p> <p>Parameter Type — Numerical</p> <p>Factory Default — 0.00</p> <p>Changeable During Run — Yes</p> <p>Minimum — Lower Limit (F013)</p> <p>Maximum — Upper Limit (F012)</p> <p>Units — Hz</p>
<p>Preset Speed #15</p> <p>Program ⇒ Pattern Run Control ⇒ Preset Speeds ⇒ 15</p> <p>This parameter assigns an output frequency to binary number 1111 and is identified as Preset Speed #15. The binary number is applied to S1 – S4 of the Control Terminal Strip to output the Preset Speed (see F018 for further information on this parameter).</p>	<p>Direct Access Number — F294</p> <p>Parameter Type — Numerical</p> <p>Factory Default — 0.00</p> <p>Changeable During Run — Yes</p> <p>Minimum — Lower Limit (F013)</p> <p>Maximum — Upper Limit (F012)</p> <p>Units — Hz</p>

PWM Carrier Frequency

Program ⇒ Special Control Parameters ⇒ **Carrier Frequency**

This parameter sets the frequency of the pulse width modulation signal applied to the motor.

Note: *The carrier frequency must be 2.2 kHz or above except while operating in the **Constant Torque, Variable Torque, or the 5-Point Setting** modes.*

Note: *The maximum **Carrier Frequency** setting allowed is 5.0 kHz for the following ASDs:*

230-volt ⇒ 75 HP – 150 HP.

460-volt ⇒ 150 HP – 350 HP.

600-volt ⇒ 150 HP – 300 HP.

*The maximum **Carrier Frequency** setting allowed for all other ASDs is 15 kHz.*

Setting the Carrier Frequency above the Derate Threshold frequency (as listed below) for a given ASD will reduce the capability of the ASD.

Carrier-Frequency Derate Threshold Frequency

Derate Threshold Frequency			
2.2 kHz	5.0 kHz	6.0 kHz	8.0 kHz
H X 7			
2750B – 215K	2500	6160	2010 – 2600
2750B – 215K	2600	6400	2400
415KB – 435K	4400	6400	4015 – 4330
415KB – 435K	412K		4500 – 410K
615KB – 635K	410K		4600 – 4750
	412K		6015 – 6120
	610K		6220 – 6330
	610K		6220 – 6330
	612K		6500 – 6750
			6500 – 6750

Direct Access Number — F300

Parameter Type — **Numerical**

Factory Default — **2.200**

Changeable During Run — **No**

Minimum — 0.500

Maximum — (ASD-dependent)

Units — kHz

Example

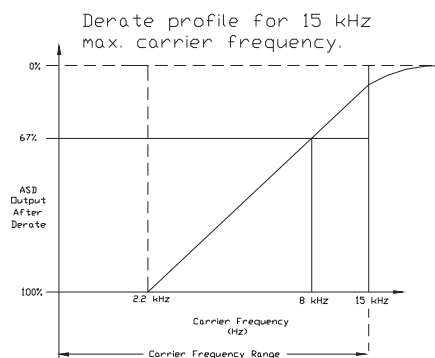

Break/Make ST

Program ⇒ Protection Parameters ⇒ **Retry/Restart**

This parameter **Enables/Disables** the ability of the drive to start into a spinning motor when the **ST – CC** connection opens momentarily and is then closed (Break/Make ST) or after a power interruption (momentary power failure). This parameter also **Enables/Disables** **F312** and **F313**.

Settings:

Box checked (Enabled)

Box not checked (Disabled)

Direct Access Number — F301

Parameter Type — **Check Box**

Factory Default — **Disabled**

Changeable During Run — **Yes**

Ridethrough ModeProgram ⇒ Protection Parameters ⇒ **Undervoltage/Ridethrough**

This parameter determines the motor-control response of the drive in the event of a momentary power outage.

Settings:

- Off
- Ridethrough
- Stop

Direct Access Number — F302Parameter Type — **Selection List**Factory Default — **Off**Changeable During Run — **Yes**

Number of RetriesProgram ⇒ Protection Parameters ⇒ **Retry/Restart**

After a trip has occurred, this parameter sets the number of times that an automatic system restart is attempted for a qualified trip.

The trip conditions listed below will not initiate the automatic **Retry/Restart** function:

- U, V, W phase short circuit,
- DBR Resistor Overcurrent (Not used) ,
- Input Phase Loss (Input Phase Failure),
- Output Phase Loss (Output Phase Failure),
- Overcurrent During Acceleration (Startup Overcurrent),
- Earth Fault (Ground Fault),
- EMG (Emergency Off),
- EEPROM Data Fault (EEPROM Fault),
- Flash Memory/Gate Array/RAM-ROM Fault,
- CPU Fault,
- Communication Error,
- Option Fault,
- Output Current Protection Fault,
- Sink/Source Setting Error,
- Overspeed Error, or
- Key Error.

See the section titled [General Safety Information on pg. 1](#) for further information on this setting.

Direct Access Number — F303Parameter Type — **Numerical**Factory Default — **00**Changeable During Run — **Yes**

Minimum — 00

Maximum — 10

Dynamic Braking Enable

Program ⇒ Protection Parameters ⇒ **Dynamic Braking** (not used)

This parameter **Enables/Disables** the **Dynamic Braking** system.

Settings:

Enabled with Overload

Disabled

Dynamic Braking

Dynamic Braking uses the inertial energy of the load to produce a braking force or it may be used to reduce the bus voltage in an attempt to preclude an overvoltage trip during deceleration. The inertial energy of the load drives the rotor and induces a current into the stator of the motor.

The induced stator current (energy) is dissipated through a resistive load. The resistive load is connected across terminals **PA** and **PB** (non-polarized). Using a low-value, high-wattage resistance as a load for the generated current, the resistive load dissipates the induced energy. The dissipated energy is the energy that would otherwise have caused the rotor to continue to rotate.

Dynamic Braking helps to slow the load quickly; it cannot act as a holding brake.

The **Dynamic Braking** function may be setup and enabled by connecting a braking resistor from terminal **PA** to **PB** of the drive and providing the proper information at **F304**, **F308**, and **F309**.

For additional information on selecting the proper resistance value for a given application contact **Toshiba's Marketing Department**.

Direct Access Number — **F304**

Parameter Type — **Selection List**

Factory Default — **Disabled**

Changeable During Run — **No**

Overvoltage Stall

Program ⇒ Protection Parameters ⇒ **Stall**

This parameter **Enables/Disables** the **Overvoltage Stall** function. When enabled, this function causes the drive to extend the decel time when the DC bus voltage increases due to transient voltage spikes, regeneration, supply voltage out of specification, etc. in an attempt to reduce the bus voltage.

Settings:

Enabled

Disabled

Enabled (Forced Shorted Deceleration)

Direct Access Number — **F305**

Parameter Type — **Selection List**

Factory Default — **Enabled**

Changeable During Run — **Yes**

Motor #1 Max Output Voltage

Program ⇒ Motor Parameters ⇒ **Motor Set #1**

This parameter sets the maximum value of the output voltage of the drive. The **Motor #1 Maximum Output Voltage** is the **Motor #1** output voltage at the **Base Frequency (F014)**. Regardless of the programmed value, the output voltage cannot be higher than the input voltage.

The actual output voltage will be influenced by the input voltage of the ASD and the **Supply Voltage Compensation** setting (**F307**).

Direct Access Number — **F306**

Parameter Type — **Numerical**

Factory Default — (ASD dependent)

Changeable During Run — **Yes**

Minimum — 0.0

Maximum — 600.0

Units — Volts

<p>Supply Voltage Compensation</p> <p>Program ⇒ Protection Parameters ⇒ Base Frequency Voltage</p> <p>This parameter Enables/Disables the Voltage Compensation function. This function provides an output waveform adjustment that compensates for changes in the input voltage.</p> <p>Settings:</p> <ul style="list-style-type: none"> Box checked (Enabled) Box not checked (Disabled) 	<p>Direct Access Number — F307</p> <p>Parameter Type — Check Box</p> <p>Factory Default — Enabled</p> <p>Changeable During Run — No</p>
<p>Dynamic Braking Resistance</p> <p>Program ⇒ Protection Parameters ⇒ Dynamic Braking (not used)</p> <p>This parameter is used to input the resistive value of the Dynamic Braking Resistor.</p> <p>For additional information on selecting the proper resistance value for a given application contact Toshiba's Marketing Department.</p> <p><i>Note:</i> Using a resistor value that is too low may result in system damage.</p>	<p>Direct Access Number — F308</p> <p>Parameter Type — Numerical</p> <p>Factory Default — (ASD-dependent)</p> <p>Changeable During Run — No</p> <p>Minimum — 1.0</p> <p>Maximum — 1000.0</p> <p>Units — Ω</p>
<p>Dynamic Braking Resistance Capacity</p> <p>Program ⇒ Protection Parameters ⇒ Dynamic Braking (not used)</p> <p>This parameter is used to input the wattage of the Dynamic Braking Resistor.</p> <p>For additional information on selecting the proper resistor wattage value for a given application contact Toshiba's Marketing Department.</p> <p><i>Note:</i> Using a resistor with a wattage rating that is too low may result in system damage.</p>	<p>Direct Access Number — F309</p> <p>Parameter Type — Numerical</p> <p>Factory Default — (ASD-dependent)</p> <p>Changeable During Run — No</p> <p>Minimum — 0.01</p> <p>Maximum — 600.0</p> <p>Units — kW</p>
<p>Ridethrough Time</p> <p>Program ⇒ Protection Parameters ⇒ Retry/Restart</p> <p>In the event of a momentary power outage, this parameter determines the length of the Ridethrough time. During a Ridethrough, regenerative energy is used to maintain the control circuitry settings; it is not used to drive the motor.</p> <p>The Ridethrough will be maintained for the number of seconds set using this parameter.</p> <p><i>Note:</i> The actual Ridethrough Time is load-dependent.</p>	<p>Direct Access Number — F310</p> <p>Parameter Type — Numerical</p> <p>Factory Default — 2.00</p> <p>Changeable During Run — Yes</p> <p>Minimum — 0.00</p> <p>Maximum — 320.0</p> <p>Units — Seconds</p>
<p>Disable Forward Run/Disable Reverse Run</p> <p>Program ⇒ Frequency Setting Parameters ⇒ Forward/Reverse Disable</p> <p>This parameter Enables/Disables the Forward Run or Reverse Run mode.</p> <p>If either direction is disabled (box checked), commands received for the disabled direction will not be recognized.</p> <p>If both directions are disabled (both boxes checked), the received direction command will determine the direction of the motor rotation.</p> <p>Settings:</p> <ul style="list-style-type: none"> Disabled Enabled 	<p>Direct Access Number — F311</p> <p>Parameter Type — Check Box</p> <p>Factory Default — Disabled</p> <p>Changeable During Run — No</p>

<p>Scan Rate</p> <p>Program ⇒ Protection Parameters ⇒ Retry/Restart</p> <p>In the event of a momentary power outage, the output signal of the drive will cease. Upon restoration of power, the drive will output a low-level signal that will be used to determine the rotation speed of the rotor.</p> <p>The low-level signal will start scanning the motor at the Maximum Frequency and decrease until it reaches 0.0 Hz or it matches the signal produced by the turning rotor. Once the rate of rotation is determined, the drive will provide the normal output to engage the motor from its present speed.</p> <p>This parameter determines the rate at which the scanning signal goes from the Maximum Frequency to 0.0 Hz. See F301 for additional information on this parameter.</p>	<p>Direct Access Number — F312</p> <p>Parameter Type — Numerical</p> <p>Factory Default — (ASD-dependent)</p> <p>Changeable During Run — No</p> <p>Minimum — 0.50</p> <p>Maximum — 2.50</p>
<p>Lock-on Rate</p> <p>Program ⇒ Protection Parameters ⇒ Retry/Restart</p> <p>After a momentary power outage, the ASD may have to startup into a spinning motor. The Lock On Rate is the difference between the time that the RPM of the motor is determined by the ASD and the time that the ASD outputs a drive signal to the motor.</p> <p>See F301 for additional information on this parameter.</p>	<p>Direct Access Number — F313</p> <p>Parameter Type — Numerical</p> <p>Factory Default — (ASD-dependent)</p> <p>Changeable During Run — No</p> <p>Minimum — 0.50</p> <p>Maximum — 2.50</p>
<p>Search Method</p> <p>Program ⇒ Protection Parameters ⇒ Retry/Restart</p> <p>In the event of a momentary power outage, this parameter may be used to set the starting point (frequency) of the scanning signal that is used to determine the rotor speed or this parameter may be used to select the method used to search for the speed of the rotor. See F301 and F312 for additional information on this parameter.</p> <p>Settings:</p> <ul style="list-style-type: none"> Normal Start from 0.0 Hz Start from Running Frequency Option Board (ASD-SS) PG 	<p>Direct Access Number — F314</p> <p>Parameter Type — Selection List</p> <p>Factory Default — Normal</p> <p>Changeable During Run — No</p>
<p>Search Inertia</p> <p>Program ⇒ Protection Parameters ⇒ Retry/Restart</p> <p>After a momentary power loss or the momentary loss of the ST-to-CC connection, this parameter sets the time for the commanded torque to reach its programmed setting during the automatic restart. This function is in effect so long as the Retry/Restart feature is enabled at F301.</p> <p>Settings:</p> <ul style="list-style-type: none"> 0.5 Sec. (fast) 1.0 Sec. (standard) 1.5 Sec. 2.0 Sec. 2.5 Sec. 3.0 Sec. 3.5 Sec. 4.0 Sec. 4.5 Sec. 5.0 Sec. (slow) 	<p>Direct Access Number — F315</p> <p>Parameter Type — Selection List</p> <p>Factory Default — 1.0</p> <p>Changeable During Run — No</p> <p>Units — Seconds</p>

<p>Drooping Gain</p> <p>Program ⇒ Feedback Parameters ⇒ Drooping Control</p> <p>This parameter sets the effective 100% output torque level while operating in the Drooping Control mode. This value is the upper torque limit of the motor being driven by a given ASD while operating in the Drooping Control mode.</p> <p>Drooping</p> <p>Drooping Control, also called Load Share, is used to share the load among two or more mechanically coupled motors. Unlike Stall, which reduces the output frequency in order to limit the load once the load reaches a preset level, Drooping can decrease or increase the V/f setting of a motor to maintain a balance between the output torque levels of mechanically coupled motors.</p> <p>Because of variances in gearboxes, sheaves, belts, motors, and since the speed of the motor is constrained by the mechanical system, one motor may experience more load than its counterpart and may become overloaded.</p> <p>Drooping Control allows the overloaded motor to slow down, thus shedding load and encouraging a lightly-loaded motor to pick up the slack. The goal of Drooping Control is to have the same torque ratios for mechanically coupled motors.</p>	<p>Direct Access Number — F320</p> <p>Parameter Type — Numerical</p> <p>Factory Default — 0.00</p> <p>Changeable During Run — Yes</p> <p>Minimum — 0.00</p> <p>Maximum — 100.0</p> <p>Units — %</p>
<p>Speed at Drooping Gain 0%</p> <p>Program ⇒ Feedback Parameters ⇒ Drooping Control</p> <p>This parameter sets the motor speed when at the 0% output torque gain while operating in the Drooping Control mode. This function determines the lowest speed that Drooping will be in effect for motors that share the same load.</p>	<p>Direct Access Number — F321</p> <p>Parameter Type — Numerical</p> <p>Factory Default — 60.00</p> <p>Changeable During Run — Yes</p> <p>Minimum — 0.00</p> <p>Maximum — 320.0</p> <p>Units — Hz</p>
<p>Speed at Drooping Gain 100%</p> <p>Program ⇒ Feedback Parameters ⇒ Drooping Control</p> <p>This parameter sets the motor speed when at the 100% output torque gain while operating in the Drooping Control mode. This function determines the speed of the individual motors at the 100% Drooping Gain setting for motors that share the same load.</p>	<p>Direct Access Number — F322</p> <p>Parameter Type — Numerical</p> <p>Factory Default — 60.00</p> <p>Changeable During Run — Yes</p> <p>Minimum — 0.00</p> <p>Maximum — 320.0</p> <p>Units — Hz</p>
<p>Drooping Insensitive Torque Range</p> <p>Program ⇒ Feedback Parameters ⇒ Drooping Control</p> <p>This parameter defines a torque range in which the Drooping Control settings will be ignored and the programmed torque settings will be followed.</p>	<p>Direct Access Number — F323</p> <p>Parameter Type — Numerical</p> <p>Factory Default — 10.00</p> <p>Changeable During Run — Yes</p> <p>Minimum — 0.00</p> <p>Maximum — 100.0</p> <p>Units — %</p>
<p>Drooping Output Filter</p> <p>Program ⇒ Feedback Parameters ⇒ Drooping Control</p> <p>This parameter is used to set the rate of output change allowed while operating in the Drooping Control mode.</p> <p>Jerky operation may be decreased by increasing this setting.</p>	<p>Direct Access Number — F324</p> <p>Parameter Type — Numerical</p> <p>Factory Default — 100.0</p> <p>Changeable During Run — Yes</p> <p>Minimum — 0.1</p> <p>Maximum — 200.0</p>

<p>Load Inertia (Acc/Dec Torque)</p> <p>Program ⇒ Feedback Parameters ⇒ Drooping Control ⇒ Load Inertia</p> <p>This parameter is used for calculating accel/decel torque when compensating for load inertia while operating in the Drooping Control mode.</p>	<p>Direct Access Number — F325</p> <p>Parameter Type — Numerical</p> <p>Factory Default — 1.0</p> <p>Changeable During Run — Yes</p> <p>Minimum — 0.0</p> <p>Maximum — 1000.0</p>
<p>Load Torque Filter (Acc/Dec Torque)</p> <p>Program ⇒ Feedback Parameters ⇒ Drooping Control ⇒ Load Inertia</p> <p>This parameter is used to set the response sensitivity when calculating the accel/decel torque. This setting applies to load inertia compensation while operating in the Drooping Control mode.</p> <p>This parameter should be gradually adjusted to provide smoother Drooping Control operation while operating with heavy loads.</p>	<p>Direct Access Number — F326</p> <p>Parameter Type — Numerical</p> <p>Factory Default — 200.0</p> <p>Changeable During Run — Yes</p> <p>Minimum — 0.0</p> <p>Maximum — 200.0</p>
<p>Drooping Reference</p> <p>Program ⇒ Feedback Parameters ⇒ Drooping Control ⇒ Drooping Reference</p> <p>This parameter sets the method to be used in determining the output torque while operating in the Drooping Control mode.</p> <p>Settings:</p> <ul style="list-style-type: none"> Total Torque Calculated by the Detection Current. Torque without Acc/Dec Torque Calculated by Detection Current. Total Torque Calculated by the Command Current. Torque without Acc/Dec Torque Calculated by the Command Current. 	<p>Direct Access Number — F327</p> <p>Parameter Type — Selection List</p> <p>Factory Default — Total torque calculated by the detection current</p> <p>Changeable During Run — Yes</p>
<p>Light-load High-speed Operation Selection</p> <p>Program ⇒ Special Control Parameters ⇒ Crane/Hoist Settings ⇒ Express Speed Settings ⇒ Light-Load High-Speed Operation</p> <p>This parameter enables the Light-Load High-Speed function by selecting an operating mode. The Light-Load High-Speed function accelerates the output frequency of the ASD from the programmed speed to the setting established in F341.</p> <p>This parameter may be disabled.</p> <p>If either of the other selections are made and configured, and after the criteria of F331 – F333 are met, the Light-Load High-Speed function is enabled and this parameter determines the operating mode of the Light-Load High-Speed function.</p> <p>Settings:</p> <ul style="list-style-type: none"> Disabled Reserved Automatic Enable - Automatic Speed (F341) Automatic Enable - Preset Speed (Preset ID_{Bin} is OR'ed w/1000_{Bin}) Discrete Enable - Automatic Speed (F341) (see item 60 of Table 5 on pg. 162) Discrete Enable - Preset Speed (Preset ID_{Bin} is OR'ed w/1000_{Bin}) (see item 60 of Table 5 on pg. 162) 	<p>Direct Access Number — F330</p> <p>Parameter Type — Selection List</p> <p>Factory Default — Disabled</p> <p>Changeable During Run — No</p> <p>Minimum — 30.0</p> <p>Maximum — Upper Limit (F012)</p> <p>Units — Hz</p>

<p>Light-Load High-Speed Operation Switching Lower-Limit Frequency</p> <p>Program ⇒ Special Control Parameters ⇒ Crane/Hoist Settings ⇒ Express Speed Settings ⇒ Light-Load High-Speed Operation Switching Lower-Limit Frequency</p> <p>This parameter sets an output frequency threshold that, once surpassed, allows the Light-load High-speed function to be used.</p> <p>The Light-Load High-Speed function may be used if the frequency threshold (F331) and the following conditions are met:</p> <ol style="list-style-type: none"> 1) Light-Load High-Speed Operation Enable is configured at F330. 2) The output torque is less than the setting established in F335 when reaching the frequency setting here. 	<p>Direct Access Number — F331</p> <p>Parameter Type — Numerical</p> <p>Factory Default — 40.00</p> <p>Changeable During Run — Yes</p> <p>Minimum — 30.0</p> <p>Maximum — Upper Limit (F012)</p> <p>Units — Hz</p>
<p>Light-Load High-Speed Operation Load Wait Time</p> <p>Program ⇒ Special Control Parameters ⇒ Crane/Hoist Settings ⇒ Express Speed Settings ⇒ Light-Load High-Speed Operation Load Wait-Time</p> <p>After the time setting of F333 times out, this parameter determines the length of time that the Light-Load High-Speed criteria must be met until the Light-Load High-Speed function engages.</p>	<p>Direct Access Number — F332</p> <p>Parameter Type — Numerical</p> <p>Factory Default — 1.0</p> <p>Changeable During Run — Yes</p> <p>Minimum — 0.0</p> <p>Maximum — 10.0</p> <p>Units — Seconds</p>
<p>Light-Load High-Speed Operation Load Detection Time</p> <p>Program ⇒ Special Control Parameters ⇒ Crane/Hoist Settings ⇒ Express Speed Settings ⇒ Light-Load High-Speed Operation Load Detection Time</p> <p>This parameter determines the length of time that the load requirement must meet the Light-Load High-Speed criteria before the Light-Load High-Speed Enable (F330) is recognized.</p> <p>Once recognized, the timer setting of F332 must expire to engage the Light-Load High-Speed function.</p>	<p>Direct Access Number — F333</p> <p>Parameter Type — Yes</p> <p>Factory Default — 1.0</p> <p>Changeable During Run — Numerical</p> <p>Minimum — 0.0</p> <p>Maximum — 10.0</p> <p>Units — Seconds</p>
<p>Light-Load High-Speed Operation Heavy-Load Detection Time</p> <p>Program ⇒ Special Control Parameters ⇒ Crane/Hoist Settings ⇒ Express Speed Settings ⇒ Light-Load High-Speed Operation Heavy-Load Detection Time</p> <p>While operating in the Light-Load High-Speed mode, this parameter determines the length of time that a load exceeding the Light-Load High-Speed operation criteria may exist before the Light-Load High-Speed mode is terminated and normal operation resumes.</p>	<p>Direct Access Number — F334</p> <p>Parameter Type — Numerical</p> <p>Factory Default — 5.0</p> <p>Changeable During Run — Yes</p> <p>Minimum — 0.0</p> <p>Maximum — 10.0</p> <p>Units — Seconds</p>
<p>Switching Load Torque During Forward-Run</p> <p>Program ⇒ Special Control Parameters ⇒ Crane/Hoist Settings ⇒ Express Speed Settings ⇒ Switching Load Torque During Forward Run</p> <p>While running forward, this parameter establishes the threshold torque level that is used to determine if the Light-Load High-Speed (F331) operation may engage or remain engaged if active.</p> <p>If the Light-Load High-Speed operation is terminated normal operation resumes.</p>	<p>Direct Access Number — F335</p> <p>Parameter Type — Numerical</p> <p>Factory Default — 50</p> <p>Changeable During Run — No</p> <p>Minimum — 0</p> <p>Maximum — 250</p> <p>Units — %</p>

<p>Heavy-Load Torque During Forward Acceleration</p> <p>Program ⇒ Special Control Parameters ⇒ Crane/Hoist Settings ⇒ Express Speed Settings ⇒ Heavy-Load Torque During Forward Acceleration</p> <p>During forward acceleration, this parameter establishes the threshold torque level that is used to determine if the Light-Load High-Speed (F331) operation may engage or remain engaged if active.</p> <p>If the Light-Load High-Speed operation is terminated normal operation resumes.</p>	<p>Direct Access Number — F336</p> <p>Parameter Type — Numerical</p> <p>Factory Default — 150</p> <p>Changeable During Run — Yes</p> <p>Minimum — 0</p> <p>Maximum — 250</p> <p>Units — %</p>
<p>Heavy-Load Torque During Forward Deceleration</p> <p>Program ⇒ Special Control Parameters ⇒ Crane/Hoist Settings ⇒ Express Speed Settings ⇒ Heavy-Load Torque During Forward Deceleration</p> <p>During forward deceleration, this parameter establishes the threshold torque level that is used to determine if the Light-Load High-Speed (F331) operation may engage or remain engaged if active.</p> <p>If the Light-Load High-Speed operation is terminated normal operation resumes.</p>	<p>Direct Access Number — F337</p> <p>Parameter Type — Numerical</p> <p>Factory Default — 100</p> <p>Changeable During Run — Yes</p> <p>Minimum — 0</p> <p>Maximum — 250</p> <p>Units — %</p>
<p>Switching Load Torque During Reverse-Run</p> <p>Program ⇒ Special Control Parameters ⇒ Crane/Hoist Settings ⇒ Express Speed Settings ⇒ Switching Load Torque During Reverse Run</p> <p>While running in reverse, this parameter establishes the threshold torque level that is used to determine if the Light-Load High-Speed (F331) operation may engage or remain engaged if active.</p> <p>If the Light-Load High-Speed operation is terminated normal operation resumes.</p>	<p>Direct Access Number — F338</p> <p>Parameter Type — Numerical</p> <p>Factory Default — 50</p> <p>Changeable During Run — Yes</p> <p>Minimum — 0</p> <p>Maximum — 250</p> <p>Units — %</p>
<p>Heavy-Load Torque During Reverse Acceleration</p> <p>Program ⇒ Special Control Parameters ⇒ Crane/Hoist Settings ⇒ Express Speed Settings ⇒ Heavy-Load Torque During Reverse Acceleration</p> <p>During reverse acceleration, this parameter establishes the threshold torque level that is used to determine if the Light-Load High-Speed (F331) operation may engage or remain engaged if active.</p> <p>If the Light-Load High-Speed operation is terminated normal operation resumes.</p>	<p>Direct Access Number — F339</p> <p>Parameter Type — Numerical</p> <p>Factory Default — 150</p> <p>Changeable During Run — Yes</p> <p>Minimum — 0</p> <p>Maximum — 250</p> <p>Units — %</p>
<p>Heavy-Load Torque During Reverse Deceleration</p> <p>Program ⇒ Special Control Parameters ⇒ Crane/Hoist Settings ⇒ Express Speed Settings ⇒ Heavy-Load Torque During Reverse Deceleration</p> <p>During reverse deceleration, this parameter establishes the threshold torque level that is used to determine if the Light-Load High-Speed (F331) operation may engage or remain engaged if active.</p> <p>If the Light-Load High-Speed operation is terminated normal operation resumes.</p>	<p>Direct Access Number — F340</p> <p>Parameter Type — Numerical</p> <p>Factory Default — 100</p> <p>Changeable During Run — Yes</p> <p>Minimum — 0</p> <p>Maximum — 250</p> <p>Units — %</p>

Frequency for Automatic High-Speed Operation at Light-Load

Program ⇒ Special Control Parameters ⇒ Crane/Hoist Settings ⇒ Express Speed Settings ⇒ **Frequency for Automatic High-Speed Operation at Light-Load**

This parameter establishes the speed that the ASD will ramp to when operating in the **Light-Load High-Speed** mode.

Direct Access Number — F341

Parameter Type — Numerical

Factory Default — 80

Changeable During Run — Yes

Minimum — 0.00

Maximum — 80.00

Units — %

On-Trip Powerline Switching

Program ⇒ Terminal Selection Parameters ⇒ **Line Power Switching**

This parameter **Enables/Disables** the **On Trip Powerline Switching** feature. When enabled, the system is instructed to discontinue using the output of the drive and to switch to the commercial power in the event of a trip.

Settings:

Disabled

Enabled (box checked)

Direct Access Number — F354

Parameter Type — Check Box

Factory Default — Disabled

Changeable During Run — No

At-Frequency Powerline Switching

Program ⇒ Terminal Selection Parameters ⇒ **Line Power Switching**

When enabled, this parameter sets the frequency at which the **At Frequency Powerline Switching** function engages. The **At Frequency Powerline Switching** function commands the system to discontinue using the output of the drive and to switch to commercial power once reaching the frequency set here.

Direct Access Number — F355

Parameter Type — Numerical

Factory Default — 60.00

Changeable During Run — Yes

Minimum — 0.00

Maximum — **Max. Freq. (F011)**

Units — Hz

ASD-side Switching Wait Time

Program ⇒ Terminal Selection Parameters ⇒ **Line Power Switching**

This parameter determines the amount of time that the drive will wait before outputting a signal to the motor once the switch-to-drive-output criteria has been met.

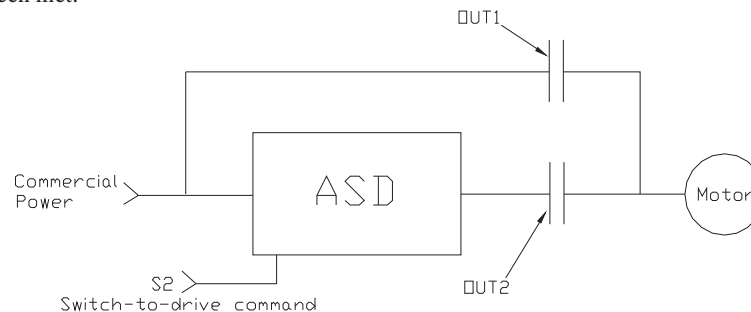

Direct Access Number — F356

Parameter Type — Numerical

Factory Default — (ASD-dependent)

Changeable During Run — Yes

Minimum — 0.01

Maximum — 10.00

Units — Seconds

Commercial Power Wait Time

Program ⇒ Terminal Selection Parameters ⇒ **Line Power Switching**

This parameter determines the amount of time that the drive will wait before allowing commercial power to be applied to the motor once the switch-to-commercial-power criteria has been met.

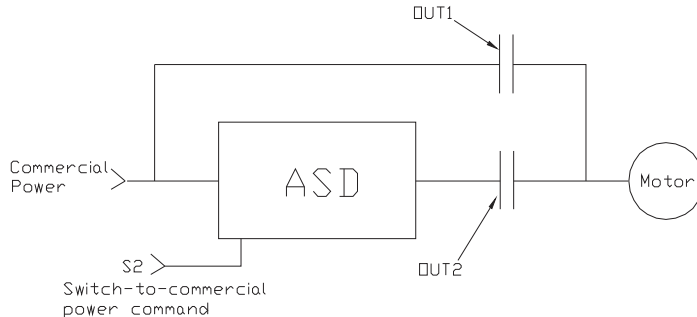

Direct Access Number — F357

Parameter Type — **Numerical**

Factory Default — **0.62**

Changeable During Run — **Yes**

Minimum — (ASD-dependent)

Maximum — 10.00

Units — Seconds

Commercial Power Switching Freq. Hold Time

Program ⇒ Terminal Selection Parameters ⇒ **Line Power Switching**

This parameter determines the amount of time that the connection to commercial power is maintained once the switch-to-drive-output criteria has been met.

Direct Access Number — F358

Parameter Type — **Numerical**

Factory Default — **2.00**

Changeable During Run — **Yes**

Minimum — 0.10

Maximum — 10.00

Units — Seconds

Feedback Source

Program ⇒ Feedback Parameters ⇒ **Feedback Settings**

This parameter **Enables/Disables PID** feedback control. When enabled, this parameter determines the source of the motor-control feedback.

Settings:

- PID Control Disabled
- VI/II
- RR
- RX
- RX2 (option)

Proportional-Integral-Derivative (PID) — A closed-loop control technique that seeks error minimization by reacting to three values: One that is proportional to the error, one that is representative of the error, and one that is representative of the rate of change of the error.

Direct Access Number — F360

Parameter Type — **Selection List**

Factory Default — **Control Disabled**

Changeable During Run — **Yes**

Feedback Source Delay Filter

Program ⇒ Feedback Parameters ⇒ **Feedback Settings**

This parameter determines the delay in the ASD output response to the motor-control feedback signal (signal source is selected at **F360**).

Direct Access Number — F361

Parameter Type — **Numerical**

Factory Default — **0**

Changeable During Run — **Yes**

Minimum — 0

Maximum — 255

<p>Proportional (P) Gain</p> <p>Program ⇒ Feedback Parameters ⇒ Feedback Settings</p> <p>This parameter determines the degree that the Proportional function affects the output signal. The larger the value entered here, the quicker the drive responds to changes in feedback.</p>	<p>Direct Access Number — F362</p> <p>Parameter Type — Numerical</p> <p>Factory Default — 0.10</p> <p>Changeable During Run — Yes</p> <p>Minimum — 0.01</p> <p>Maximum — 100.0</p>
<p>Integral (I) Gain</p> <p>Program ⇒ Feedback Parameters ⇒ Feedback Settings</p> <p>This parameter determines the degree that the Integral function affects the output signal. The smaller the value here, the more pronounced the effect of the integral function on the output signal.</p>	<p>Direct Access Number — F363</p> <p>Parameter Type — Numerical</p> <p>Factory Default — 0.10</p> <p>Changeable During Run — Yes</p> <p>Minimum — 0.01</p> <p>Maximum — 100.0</p>
<p>Upper Deviation Limits</p> <p>Program ⇒ Feedback Parameters ⇒ Feedback Settings</p> <p>This parameter determines the maximum amount that the feedback may increase the output signal.</p>	<p>Direct Access Number — F364</p> <p>Parameter Type — Numerical</p> <p>Factory Default — 50.00</p> <p>Changeable During Run — Yes</p> <p>Minimum — 0.00</p> <p>Maximum — 50.00</p> <p>Units — %</p>
<p>Lower Deviation Limits</p> <p>Program ⇒ Feedback Parameters ⇒ Feedback Settings</p> <p>This parameter determines the maximum amount that the feedback may decrease the output signal.</p>	<p>Direct Access Number — F365</p> <p>Parameter Type — Numerical</p> <p>Factory Default — 50.00</p> <p>Changeable During Run — Yes</p> <p>Minimum — 0.00</p> <p>Maximum — 50.00</p> <p>Units — %</p>
<p>Feedback Settings Differential (D) Gain</p> <p>Program ⇒ Feedback Parameters ⇒ Feedback Settings</p> <p>This parameter determines the degree that the Differential function affects the output signal. The larger the value entered here, the more pronounced the affect of the differential function for a given feedback signal level.</p>	<p>Direct Access Number — F366</p> <p>Parameter Type — Numerical</p> <p>Factory Default — 0.00</p> <p>Changeable During Run — Yes</p> <p>Minimum — 0.0</p> <p>Maximum — 2.55</p>
<p>Number of PG Input Pulses</p> <p>Program ⇒ Feedback Parameters ⇒ PG Settings</p> <p>This parameter is used to set the end-of-travel range when using an encoder on a motor-driven positioning system (e.g., hoist/crane, etc.).</p>	<p>Direct Access Number — F367</p> <p>Parameter Type — Numerical</p> <p>Factory Default — 500</p> <p>Changeable During Run — No</p> <p>Minimum — 1</p> <p>Maximum — 9999</p> <p>Units — Pulse Count</p>

PG Input Phases

Program ⇒ Feedback Parameters ⇒ **PG Settings**

This parameter determines the type of information that is supplied by the phase encoder.

Settings:

- 1 — Speed
- 2 — Speed and Direction

Direct Access Number — F368

Parameter Type — **Selection List**

Factory Default — **2**

Changeable During Run — **No**

Minimum — 1

Maximum — 2

Units — Phase Count

PG Disconnect Detection

Program ⇒ Feedback Parameters ⇒ **PG Settings**

This parameter **Enables/Disables** the system’s monitoring of the PG connection status when using encoders with line driver outputs.

Note: The ASD-Multicom-J option board is required to use this feature.

Settings:

- Disabled
- Enabled

Direct Access Number — F369

Parameter Type — **Selection List**

Factory Default — **Disabled**

Changeable During Run — **No**

Electronic Gear Setting

Program ⇒ Feedback Parameters ⇒ **PG Settings**

This parameter sets the number of pulses per revolution when using a shaft-mounted encoder and the **PG Option Board** for closed loop speed control.

Direct Access Number — F370

Parameter Type — **Numerical**

Factory Default — **1000**

Changeable During Run — **No**

Minimum — 100

Maximum — 4000

Position Loop Gain

Program ⇒ Feedback Parameters ⇒ **PG Settings**

This parameter provides a divisor for the pulse input when operating in the **Pulse Control** mode.

Direct Access Number — F371

Parameter Type — **Numerical**

Factory Default — **4.00**

Changeable During Run — **Yes**

Minimum — 0.0

Maximum — 100.0

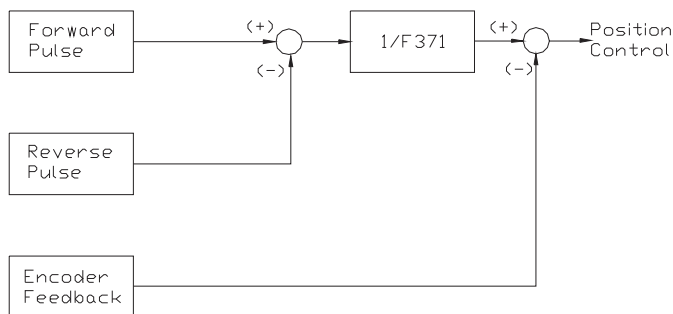

<p>Position Completion Range</p> <p>Program ⇒ Feedback Parameters ⇒ PG Settings</p> <p>During a deceleration ramp, this parameter sets a speed range that must be attained before the Stop command may be executed.</p>	<p>Direct Access Number — F372</p> <p>Parameter Type — Numerical</p> <p>Factory Default — 100</p> <p>Changeable During Run — Yes</p> <p>Minimum — 1</p> <p>Maximum — 4000</p>
<p>Frequency Limit at Position</p> <p>Program ⇒ Feedback Parameters ⇒ PG Settings</p> <p>While operating in the Position-Control mode and using PG feedback, this setting determines the maximum acceleration rate in Hz/second.</p>	<p>Direct Access Number — F373</p> <p>Parameter Type — Numerical</p> <p>Factory Default — 800</p> <p>Changeable During Run — Yes</p> <p>Minimum — 1</p> <p>Maximum — 8001</p> <p>Units — Hz/Second</p>
<p>Current Control Proportional Gain</p> <p>Program ⇒ Feedback Parameters ⇒ PG Settings</p> <p>This parameter sets the sensitivity of the drive when monitoring the output current to control speed. The larger the value entered here, the more sensitive the drive is to changes in the received feedback.</p>	<p>Direct Access Number — F374</p> <p>Parameter Type — Numerical</p> <p>Factory Default — (ASD-dependent)</p> <p>Changeable During Run — No</p> <p>Minimum — 100.0</p> <p>Maximum — 1000</p>
<p>Current Control Integral Gain</p> <p>Program ⇒ Feedback Parameters ⇒ PG Settings</p> <p>This parameter sets the degree and rate at which the output frequency will be allowed to change when prompted by changes in the output current.</p> <p>The larger the value entered here, the quicker/more the drive responds to changes in feedback.</p>	<p>Direct Access Number — F375</p> <p>Parameter Type — Numerical</p> <p>Factory Default — (ASD-dependent)</p> <p>Changeable During Run — No</p> <p>Minimum — 100.0</p> <p>Maximum — 1250</p>
<p>Speed Loop Proportional Gain</p> <p>Program ⇒ Feedback Parameters ⇒ PG Settings</p> <p>This parameter sets the Proportional Gain (sensitivity) of the drive when monitoring the PG signal to control speed. The larger the value entered here, the more sensitive the drive is to changes in the received feedback and the quicker it responds.</p>	<p>Direct Access Number — F376</p> <p>Parameter Type — Numerical</p> <p>Factory Default — (ASD-dependent)</p> <p>Changeable During Run — Yes</p> <p>Minimum — 3.2</p> <p>Maximum — 1000</p>
<p>Speed Loop Integral Gain</p> <p>Program ⇒ Feedback Parameters ⇒ PG Settings</p> <p>This parameter sets the response time of the Speed Loop Integral Gain. The smaller the value here, the more pronounced (quicker) the effect of the integral function.</p>	<p>Direct Access Number — F377</p> <p>Parameter Type — Numerical</p> <p>Factory Default — (ASD-dependent)</p> <p>Changeable During Run — Yes</p> <p>Minimum — 10.0</p> <p>Maximum — 200.0</p>

<p>Motor Counter Data</p> <p>Program ⇒ Feedback Parameters ⇒ PG Settings</p> <p>This parameter sets the pulses-per-revolution displayed at the Monitor screen when using a shaft-mounted encoder for speed control. This setting is used for display purposes only and does not affect the speed control of the system.</p> <p>If zero is selected here then the setting at F370 (Electronic Gear Setting) determines the pulses-per-revolution to be displayed at the Monitor screen.</p> <p>Settings:</p> <ul style="list-style-type: none"> Selection 0 — F370 setting Selection 1 — 256 pulses/revolution Selection 2 — 512 pulses/revolution Selection 3 — 1024 pulses/revolution Selection 4 — 2048 pulses/revolution Selection 5 — 4096 pulses/revolution 	<p>Direct Access Number — F378</p> <p>Parameter Type — Selection List</p> <p>Factory Default — Selection 0</p> <p>Changeable During Run — No</p> <p>Minimum — Selection 0</p> <p>Maximum — Selection 5</p>
<p>Speed Loop Parameter Ratio</p> <p>Program ⇒ Feedback Parameters ⇒ PG Settings</p> <p>Contact Toshiba's Marketing Department for information on this parameter.</p>	<p>Direct Access Number — F379</p> <p>Parameter Type — Numerical</p> <p>Factory Default — 1.00</p> <p>Changeable During Run — No</p> <p>Minimum — 0.01</p> <p>Maximum — 10.00</p>
<p>Use Speed Mode</p> <p>Program ⇒ Pattern Run Control Parameters ⇒ Preset Speed Mode</p> <p>This parameter Enables/Disables the Use Speed mode. When enabled, the system uses all of the parameter settings of the Preset Speed being run. Otherwise, only the frequency setting is used.</p> <p>Settings:</p> <ul style="list-style-type: none"> Disabled Enabled (box checked) 	<p>Direct Access Number — F380</p> <p>Parameter Type — Check Box</p> <p>Factory Default — Disabled</p> <p>Changeable During Run — No</p>
<p>Preset Speed Direction #1</p> <p>Program ⇒ Pattern Run Control Parameters ⇒ Preset Speeds</p> <p>Determines the forward/reverse setting for the #1 Preset Speed (F018).</p> <p>Settings:</p> <ul style="list-style-type: none"> Forward Reverse 	<p>Direct Access Number — F381</p> <p>Parameter Type — Selection List</p> <p>Factory Default — Forward</p> <p>Changeable During Run — No</p>
<p>Preset Speed Direction #2</p> <p>Program ⇒ Pattern Run Control Parameters ⇒ Preset Speeds</p> <p>Determines the forward/reverse setting for the #2 Preset Speed (F019).</p> <p>Settings:</p> <ul style="list-style-type: none"> Forward Reverse 	<p>Direct Access Number — F382</p> <p>Parameter Type — Selection List</p> <p>Factory Default — Forward</p> <p>Changeable During Run — No</p>

<p>Preset Speed Direction #3</p> <p>Program ⇒ Pattern Run Control Parameters ⇒ Preset Speeds</p> <p>Determines the forward/reverse setting for the #3 Preset Speed (F020).</p> <p>Settings:</p> <ul style="list-style-type: none"> Forward Reverse 	<p>Direct Access Number — F383</p> <p>Parameter Type — Selection List</p> <p>Factory Default — Forward</p> <p>Changeable During Run — No</p>
<p>Preset Speed Direction #4</p> <p>Program ⇒ Pattern Run Control Parameters ⇒ Preset Speeds</p> <p>Determines the forward/reverse setting for the #4 Preset Speed (F021).</p> <p>Settings:</p> <ul style="list-style-type: none"> Forward Reverse 	<p>Direct Access Number — F384</p> <p>Parameter Type — Selection List</p> <p>Factory Default — Forward</p> <p>Changeable During Run — No</p>
<p>Preset Speed Direction #5</p> <p>Program ⇒ Pattern Run Control Parameters ⇒ Preset Speeds</p> <p>Determines the forward/reverse setting for the #5 Preset Speed (F022).</p> <p>Settings:</p> <ul style="list-style-type: none"> Forward Reverse 	<p>Direct Access Number — F385</p> <p>Parameter Type — Selection List</p> <p>Factory Default — Forward</p> <p>Changeable During Run — No</p>
<p>Preset Speed Direction #6</p> <p>Program ⇒ Pattern Run Control Parameters ⇒ Preset Speeds</p> <p>Determines the forward/reverse setting for the #6 Preset Speed (F023).</p> <p>Settings:</p> <ul style="list-style-type: none"> Forward Reverse 	<p>Direct Access Number — F386</p> <p>Parameter Type — Selection List</p> <p>Factory Default — Forward</p> <p>Changeable During Run — No</p>
<p>Preset Speed Direction #7</p> <p>Program ⇒ Pattern Run Control Parameters ⇒ Preset Speeds</p> <p>Determines the forward/reverse setting for the #7 Preset Speed (F024).</p> <p>Settings:</p> <ul style="list-style-type: none"> Forward Reverse 	<p>Direct Access Number — F387</p> <p>Parameter Type — Selection List</p> <p>Factory Default — Forward</p> <p>Changeable During Run — No</p>
<p>Preset Speed Direction #8</p> <p>Program ⇒ Pattern Run Control Parameters ⇒ Preset Speeds</p> <p>Determines the forward/reverse setting for the #8 Preset Speed (F287).</p> <p>Settings:</p> <ul style="list-style-type: none"> Forward Reverse 	<p>Direct Access Number — F388</p> <p>Parameter Type — Selection List</p> <p>Factory Default — Forward</p> <p>Changeable During Run — No</p>

<p>Preset Speed Direction #9</p> <p>Program ⇒ Pattern Run Control Parameters ⇒ Preset Speeds</p> <p>Determines the forward/reverse setting for the #9 Preset Speed (F288).</p> <p>Settings:</p> <ul style="list-style-type: none"> Forward Reverse 	<p>Direct Access Number — F389</p> <p>Parameter Type — Selection List</p> <p>Factory Default — Forward</p> <p>Changeable During Run — No</p>
<p>Preset Speed Direction #10</p> <p>Program ⇒ Pattern Run Control Parameters ⇒ Preset Speeds</p> <p>Determines the forward/reverse setting for the #10 Preset Speed (F289).</p> <p>Settings:</p> <ul style="list-style-type: none"> Forward Reverse 	<p>Direct Access Number — F390</p> <p>Parameter Type — Selection List</p> <p>Factory Default — Forward</p> <p>Changeable During Run — No</p>
<p>Preset Speed Direction #11</p> <p>Program ⇒ Pattern Run Control Parameters ⇒ Preset Speeds</p> <p>Determines the forward/reverse setting for the #11 Preset Speed (F290).</p> <p>Settings:</p> <ul style="list-style-type: none"> Forward Reverse 	<p>Direct Access Number — F391</p> <p>Parameter Type — Selection List</p> <p>Factory Default — Forward</p> <p>Changeable During Run — No</p>
<p>Preset Speed Direction #12</p> <p>Program ⇒ Pattern Run Control Parameters ⇒ Preset Speeds</p> <p>Determines the forward/reverse setting for the #12 Preset Speed (F291).</p> <p>Settings:</p> <ul style="list-style-type: none"> Forward Reverse 	<p>Direct Access Number — F392</p> <p>Parameter Type — Selection List</p> <p>Factory Default — Forward</p> <p>Changeable During Run — No</p>
<p>Preset Speed Direction #13</p> <p>Program ⇒ Pattern Run Control Parameters ⇒ Preset Speeds</p> <p>Determines the forward/reverse setting for the #13 Preset Speed (F292).</p> <p>Settings:</p> <ul style="list-style-type: none"> Forward Reverse 	<p>Direct Access Number — F393</p> <p>Parameter Type — Selection List</p> <p>Factory Default — Forward</p> <p>Changeable During Run — No</p>
<p>Preset Speed Direction #14</p> <p>Program ⇒ Pattern Run Control Parameters ⇒ Preset Speeds</p> <p>Determines the forward/reverse setting for the #14 Preset Speed (F293).</p> <p>Settings:</p> <ul style="list-style-type: none"> Forward Reverse 	<p>Direct Access Number — F394</p> <p>Parameter Type — Selection List</p> <p>Factory Default — Forward</p> <p>Changeable During Run — No</p>

<p>Preset Speed Direction #15</p> <p>Program ⇒ Pattern Run Control Parameters ⇒ Preset Speeds</p> <p>Determines the forward/reverse setting for the #15 Preset Speed (F294).</p> <p>Settings:</p> <ul style="list-style-type: none"> Forward Reverse 	<p>Direct Access Number — F395</p> <p>Parameter Type — Selection List</p> <p>Factory Default — Forward</p> <p>Changeable During Run — No</p>
<p>Vector Motor Model Autotune Command</p> <p>Program ⇒ Motor Parameters ⇒ Vector Motor Model</p> <p>This parameter sets the Autotune command status.</p> <p>Settings:</p> <ul style="list-style-type: none"> Autotune Disabled Reset Motor Defaults Enable Autotune on Run Command 	<p>Direct Access Number — F400</p> <p>Parameter Type — Selection List</p> <p>Factory Default — Autotune Disabled</p> <p>Changeable During Run — No</p>
<p>Vector Motor Model Slip Frequency Gain</p> <p>Program ⇒ Motor Parameters ⇒ Vector Motor Model</p> <p>This parameter provides a degree of slip compensation for a given load. A higher setting here decreases the slip allowed for a given load/ASD output ratio.</p>	<p>Direct Access Number — F401</p> <p>Parameter Type — Numerical</p> <p>Factory Default — 0.60</p> <p>Changeable During Run — Yes</p> <p>Minimum — 0.00</p> <p>Maximum — 2.55</p>
<p>Motor Constant 1 (primary resistance)</p> <p>Program ⇒ Motor Parameters ⇒ Vector Motor Model</p> <p>This parameter is the measurement of the stator resistance and is considered a Motor Constant (unchanging). This value is used in conjunction with other constants to tune the motor.</p> <p>To use Vector Control, Automatic Torque Boost, or Automatic Energy-saving, the Motor Constant setting (motor tuning) is required.</p>	<p>Direct Access Number — F402</p> <p>Parameter Type — Numerical</p> <p>Factory Default — (ASD-dependent)</p> <p>Changeable During Run — No</p> <p>Minimum — 0.0</p> <p>Maximum — 100,000 MΩ</p> <p>Units — Ω</p>
<p>Motor Constant 2 (secondary resistance)</p> <p>Program ⇒ Motor Parameters ⇒ Vector Motor Model</p> <p>This parameter is the measurement of the rotor resistance and is considered a Motor Constant (unchanging). This value is used in conjunction with other constants to tune the motor.</p> <p>This setting (motor tuning) is required to use the Vector Control, Automatic Torque Boost, or Automatic Energy-saving functions.</p>	<p>Direct Access Number — F403</p> <p>Parameter Type — Numerical</p> <p>Factory Default — (ASD-dependent)</p> <p>Changeable During Run — No</p> <p>Minimum — 0.00</p> <p>Maximum — Open</p> <p>Units — Ω</p>
<p>Motor Constant 3 (exciting inductance)</p> <p>Program ⇒ Motor Parameters ⇒ Vector Motor Model</p> <p>This parameter is used to input the excitation inductance for the motor. This value is used in conjunction with other constants to tune the motor.</p> <p>This setting (motor tuning) is required to use the Vector Control, Automatic Torque Boost, or Automatic Energy-saving functions.</p>	<p>Direct Access Number — F404</p> <p>Parameter Type — Numerical</p> <p>Factory Default — (ASD-dependent)</p> <p>Changeable During Run — No</p> <p>Minimum — 0.00</p> <p>Maximum — 6500.0</p> <p>Units — μH</p>

<p>Motor Constant 4 (load inertia)</p> <p>Program ⇒ Motor Parameters ⇒ Vector Motor Model</p> <p>This parameter is used to control the load inertia during speed changes. Acceleration and deceleration overshoot may be reduced by increasing this value.</p> <p>This setting (motor tuning) is required to use the Vector Control, Automatic Torque Boost, or Automatic Energy-saving functions.</p>	<p>Direct Access Number — F405</p> <p>Parameter Type — Numerical</p> <p>Factory Default — 1.0</p> <p>Changeable During Run — Yes</p> <p>Minimum — 0.0</p> <p>Maximum — 100.0</p>
<p>Motor Constant 5 (leakage inductance)</p> <p>Program ⇒ Motor Parameters ⇒ Vector Motor Model</p> <p>This parameter provides slight increases in the output voltage of the drive at the high speed range.</p> <p>This setting (motor tuning) is required to use the Vector Control, Automatic Torque Boost, or Automatic Energy-saving functions.</p>	<p>Direct Access Number — F410</p> <p>Parameter Type — Numerical</p> <p>Factory Default — (ASD-dependent)</p> <p>Changeable During Run — No</p> <p>Minimum — 0.00</p> <p>Maximum — 650.0</p>
<p>Number of Poles of Motor</p> <p>Program ⇒ Motor Parameters ⇒ Motor Settings</p> <p>This parameter identifies the number of motor poles.</p>	<p>Direct Access Number — F411</p> <p>Parameter Type — Numerical</p> <p>Factory Default — 4</p> <p>Changeable During Run — No</p> <p>Minimum — 2</p> <p>Maximum — 16</p>
<p>Motor Capacity</p> <p>Program ⇒ Motor Parameters ⇒ Motor Settings</p> <p>This parameter identifies the wattage rating of the motor.</p>	<p>Direct Access Number — F412</p> <p>Parameter Type — Numerical</p> <p>Factory Default — (ASD-dependent)</p> <p>Changeable During Run — No</p> <p>Minimum — 0.10</p> <p>Maximum — (ASD-dependent)</p> <p>Units — kW</p>
<p>Motor Type</p> <p>Program ⇒ Motor Parameters ⇒ Motor Settings</p> <p>This parameter identifies the type of motor being used.</p> <p>Settings:</p> <ul style="list-style-type: none"> Toshiba EQP III TEFC Toshiba EQP III ODP Toshiba EPACT TEFC Toshiba EPACT ODP Other Motor 	<p>Direct Access Number — F413</p> <p>Parameter Type — Selection List</p> <p>Factory Default — Toshiba EQP III TEFC</p> <p>Changeable During Run — No</p>
<p>Motor Constant 3 Enable</p> <p>Program ⇒ Motor Parameters ⇒ Vector Motor Model</p> <p>This parameter Enables/Disables tuning of Motor Constant 3 during an Autotune.</p> <p>Settings:</p> <ul style="list-style-type: none"> Disabled Enabled (box checked) 	<p>Direct Access Number — F414</p> <p>Parameter Type — Check Box</p> <p>Factory Default — Enable</p> <p>Changeable During Run — No</p>

<p>Torque Command</p> <p>Program ⇒ Torque Setting Parameters ⇒ Torque Control</p> <p>When operating in the Torque Control mode, this parameter allows the user to select the source of the torque command signal.</p> <p>Settings:</p> <ul style="list-style-type: none"> VI/II RR RX RX2 (option) LED Keypad Option Binary/BCD Input Common Serial (TTL) RS232/RS485 Communication Card 	<p>Direct Access Number — F420</p> <p>Parameter Type — Selection List</p> <p>Factory Default — RX</p> <p>Changeable During Run — Yes</p>
<p>Torque Command Filter</p> <p>Program ⇒ Torque Setting Parameters ⇒ Torque Control</p> <p>This parameter reduces the motor vibration caused by large-inertia loads. A small value will have a great effect while an increased value will have a lesser effect.</p>	<p>Direct Access Number — F421</p> <p>Parameter Type — Numerical</p> <p>Factory Default — 200.0</p> <p>Changeable During Run — Yes</p> <p>Minimum — 10.0</p> <p>Maximum — 200.0</p>
<p>Synchronized Torque Bias Input</p> <p>Program ⇒ Torque Setting Parameters ⇒ Torque Control</p> <p>This parameter Enables/Disables the Synchronized Torque Bias input function. When enabled, this parameter identifies the source of the Synchronized Torque Bias input signal.</p> <p>Settings:</p> <ul style="list-style-type: none"> Disabled VI/II RR RX RX2 (option) LED Keypad Option Binary/BCD Input Common Serial (TTL) RS232/RS485 Communication Card 	<p>Direct Access Number — F422</p> <p>Parameter Type — Selection list</p> <p>Factory Default — Disabled</p> <p>Changeable During Run — Yes</p>

Tension Torque Bias InputProgram ⇒ Torque Setting Parameters ⇒ **Torque Control**

This parameter **Enables/Disables** the **Tension Torque Bias** input function and identifies the source of the **Tension Torque Bias** input signal when enabled.

Settings:

- Disabled
- VI/II
- RR
- RX
- RX2 (option)
- LED Keypad Option
- Binary/BCD Input
- Common Serial (TTL)
- RS232/RS485
- Communication Card

Direct Access Number — F423Parameter Type — **Selection List**Factory Default — **Disabled**Changeable During Run — **Yes**

Load Sharing Gain InputProgram ⇒ Torque Setting Parameters ⇒ **Torque Control**

This parameter **Enables/Disables** the **Load Sharing Gain** input function and is enabled by selecting a **Load Sharing Gain** input signal source.

Settings:

- Disabled
- VI/II
- RR
- RX
- RX2 (option)
- LED Keypad Option
- Binary/BCD Input
- Common Serial (TTL)
- RS232/RS485
- Communication Card

Direct Access Number — F424Parameter Type — **Selection List**Factory Default — **Disabled**Changeable During Run — **Yes**

Forward Speed Limit InputProgram ⇒ Torque Setting Parameters ⇒ **Torque Speed Limiting**

This parameter **Enables/Disables** the **Forward Speed Limit Input** control function. When enabled and operating in the **Torque Control** mode, the forward speed limit is controlled by the terminal selected here. If **Setting** is selected, the value set at **F426** is used as the **Forward Speed Limit** input.

Settings:

- Disabled
- VI/II
- RR
- RX
- RX2 (option)
- Setting

Direct Access Number — F425Parameter Type — **Selection List**Factory Default — **Disabled**Changeable During Run — **Yes**

<p>Forward Speed Limit Level</p> <p>Program ⇒ Torque Setting Parameters ⇒ Torque Control</p> <p>This parameter provides a value to be used as the Forward Speed Limit setting if Setting is selected at F425.</p>	<p>Direct Access Number — F426</p> <p>Parameter Type — Numerical</p> <p>Factory Default — 80.0</p> <p>Changeable During Run — Yes</p> <p>Minimum — 0.00</p> <p>Maximum — Upper Limit (F012)</p> <p>Units — Hz</p>
<p>Reverse Speed Limit Input</p> <p>Program ⇒ Torque Setting Parameters ⇒ Torque Control</p> <p>This parameter Enables/Disables the Reverse Speed Limit Input control function. When enabled and operating in the Torque Control mode, the reverse speed limit is controlled by the terminal selected here. If Setting is selected, the value set at F428 is used as the Reverse Speed Limit input.</p> <p>Settings:</p> <ul style="list-style-type: none"> Disabled VI/II RR RX RX2 (option) Setting 	<p>Direct Access Number — F427</p> <p>Parameter Type — Selection List</p> <p>Factory Default — Disabled</p> <p>Changeable During Run — Yes</p>
<p>Reverse Speed Limit Level</p> <p>Program ⇒ Torque Setting Parameters ⇒ Torque Control</p> <p>This parameter provides a value to be used as the Reverse Speed Limit setting if Setting is selected at F427.</p>	<p>Direct Access Number — F428</p> <p>Parameter Type — Numerical</p> <p>Factory Default — 80.0</p> <p>Changeable During Run — Yes</p> <p>Minimum — 0.00</p> <p>Maximum — Upper Limit (F012)</p> <p>Units — Hz</p>
<p>Torque Command Mode</p> <p>Program ⇒ Torque Setting Parameters ⇒ Torque Speed Limiting</p> <p>This parameter specifies whether the torque command function is to be used in one direction or both (F/R).</p> <p>Settings:</p> <ul style="list-style-type: none"> Fixed Direction F/R Permitted 	<p>Direct Access Number — F429</p> <p>Parameter Type — Selection List</p> <p>Factory Default — Fixed Direction</p> <p>Changeable During Run — No</p>

<p>Speed Limit (torque) Reference</p> <p>Program ⇒ Torque Setting Parameters ⇒ Torque Speed Limiting</p> <p>The system has the ability to limit the amount that the speed may vary as a function of a changing load while operating in the Torque Control mode. This parameter sets the input terminal that will be used to control the allowable speed variance.</p> <p>Settings:</p> <ul style="list-style-type: none"> None VI/II RR RX RX2 (option) Fixed 	<p>Direct Access Number — F430</p> <p>Parameter Type — Selection List</p> <p>Factory Default — None</p> <p>Changeable During Run — Yes</p>
<p>Speed Limit Torque Level</p> <p>Program ⇒ Torque Setting Parameters ⇒ Torque Speed Limiting</p> <p>The system has the ability to limit the amount that the speed may vary as a function of a changing load while operating in the Torque Control mode. This parameter sets the targeted speed. The plus-or-minus value (range) for this setting may be set at F432.</p>	<p>Direct Access Number — F431</p> <p>Parameter Type — Numerical</p> <p>Factory Default — 0.00</p> <p>Changeable During Run — Yes</p> <p>Minimum — 0.00</p> <p>Maximum — Max. Freq. (F011)</p> <p>Units — Hz</p>
<p>Speed Limit Torque Range</p> <p>Program ⇒ Torque Setting Parameters ⇒ Torque Speed Limiting</p> <p>The system has the ability to limit the amount that the speed may vary as a function of a changing load while operating in the Torque Control mode. This parameter sets a plus-or-minus value (range) for the Speed Limit Torque Level (F431).</p>	<p>Direct Access Number — F432</p> <p>Parameter Type — Numerical</p> <p>Factory Default — 0.00</p> <p>Changeable During Run — Yes</p> <p>Minimum — 0.00</p> <p>Maximum — Max. Freq. (F011)</p> <p>Units — Hz</p>
<p>Speed Limit Torque Recovery</p> <p>Program ⇒ Torque Setting Parameters ⇒ Torque Speed Limiting</p> <p>The system has the ability to limit the amount that the speed may vary as a function of a changing load while operating in the Torque Control mode. This parameter sets the response time of the system to torque change requirements.</p>	<p>Direct Access Number — F433</p> <p>Parameter Type — Numerical</p> <p>Factory Default — 0.20</p> <p>Changeable During Run — No</p> <p>Minimum — 0.00</p> <p>Maximum — 2.50</p> <p>Units — Seconds</p>

<p>Power Running Torque Limit #1</p> <p>Program ⇒ Torque Setting Parameters ⇒ Torque Limit Settings</p> <p>This parameter determines the source of the control signal for the positive torque limit setting. If Setting is selected, the value set at F441 is used as the Power Running Torque Limit #1 input.</p> <p>Settings:</p> <ul style="list-style-type: none"> VI/II RR RX RX2 (option) Setting 	<p>Direct Access Number — F440</p> <p>Parameter Type — Selection List</p> <p>Factory Default — Setting</p> <p>Changeable During Run — Yes</p>
<p>Driving Torque Limit #1</p> <p>Program ⇒ Torque Setting Parameters ⇒ Manual Torque Limit Settings</p> <p>This parameter provides a value for the Power Running Torque Limit #1 setting if Setting is selected at F440. This value provides the positive torque upper limit for the #1 motor.</p>	<p>Direct Access Number — F441</p> <p>Parameter Type — Numerical</p> <p>Factory Default — 250.0</p> <p>Changeable During Run — Yes</p> <p>Minimum — 0.00</p> <p>Maximum — 250.0</p> <p>Units — %</p>
<p>Regeneration Torque Limit #1</p> <p>Program ⇒ Torque Setting Parameters ⇒ Torque Limit Settings</p> <p>This parameter determines the source of the Regenerative Torque Limit control signal. If Setting is selected, the value set at F443 is used for this parameter.</p> <p>Settings:</p> <ul style="list-style-type: none"> VI/II RR RX RX2 (option) Setting 	<p>Direct Access Number — F442</p> <p>Parameter Type — Selection List</p> <p>Factory Default — Setting</p> <p>Changeable During Run — Yes</p>
<p>Regeneration Torque Limit Setting #1</p> <p>Program ⇒ Torque Setting Parameters ⇒ Torque Limit Settings ⇒ Manual Settings</p> <p>This parameter provides a value to be used as the Regeneration Torque Limit #1 if Setting is selected at F442.</p>	<p>Direct Access Number — F443</p> <p>Parameter Type — Numerical</p> <p>Factory Default — 250.0</p> <p>Changeable During Run — Yes</p> <p>Minimum — 0.00</p> <p>Maximum — 250.0</p> <p>Units — %</p>
<p>Driving Torque Limit #2</p> <p>Program ⇒ Torque Setting Parameters ⇒ Manual Torque Limit Settings</p> <p>This parameter is used to set the positive torque upper limit for the #2 motor profile when multiple motors are controlled by a single drive or when a single motor is to be controlled by multiple profiles.</p>	<p>Direct Access Number — F444</p> <p>Parameter Type — Numerical</p> <p>Factory Default — 250.0</p> <p>Changeable During Run — Yes</p> <p>Minimum — 0.00</p> <p>Maximum — 250.0</p> <p>Units — %</p>

<p>Regeneration Torque Limit #2</p> <p>Program ⇒ Torque Setting Parameters ⇒ Manual Torque Limit Settings</p> <p>This parameter is used to set the negative torque upper limit for the #2 motor profile when multiple motors are controlled by a single drive or when a single motor is to be controlled by multiple profiles.</p>	<p>Direct Access Number — F445</p> <p>Parameter Type — Numerical</p> <p>Factory Default — 250.0</p> <p>Changeable During Run — Yes</p> <p>Minimum — 0.00</p> <p>Maximum — 250.0</p> <p>Units — %</p>
<p>Driving Torque Limit #3</p> <p>Program ⇒ Torque Setting Parameters ⇒ Manual Torque Limit Settings</p> <p>This parameter is used to set the positive torque upper limit for the #3 motor profile when multiple motors are controlled by a single drive or when a single motor is to be controlled by multiple profiles.</p>	<p>Direct Access Number — F446</p> <p>Parameter Type — Numerical</p> <p>Factory Default — 250.0</p> <p>Changeable During Run — Yes</p> <p>Minimum — 0.00</p> <p>Maximum — 250.0</p> <p>Units — %</p>
<p>Regeneration Torque Limit #3</p> <p>Program ⇒ Torque Setting Parameters ⇒ Manual Torque Limit Settings</p> <p>This parameter is used to set the negative torque upper limit for the #3 motor profile when multiple motors are controlled by a single drive or when a single motor is to be controlled by multiple profiles.</p>	<p>Direct Access Number — F447</p> <p>Parameter Type — Numerical</p> <p>Factory Default — 250.0</p> <p>Changeable During Run — Yes</p> <p>Minimum — 0.00</p> <p>Maximum — 250.0</p> <p>Units — %</p>
<p>Driving Torque Limit #4</p> <p>Program ⇒ Torque Setting Parameters ⇒ Manual Torque Limit Settings</p> <p>This parameter is used to set the positive torque upper limit for the #4 motor profile when multiple motors are controlled by a single drive or when a single motor is to be controlled by multiple profiles.</p>	<p>Direct Access Number — F448</p> <p>Parameter Type — Numerical</p> <p>Factory Default — 250.0</p> <p>Changeable During Run — Yes</p> <p>Minimum — 0.00</p> <p>Maximum — 250.0</p> <p>Units — %</p>
<p>Regeneration Torque Limit #4</p> <p>Program ⇒ Torque Setting Parameters ⇒ Manual Torque Limit Settings</p> <p>This parameter is used to set the negative torque upper limit for the #4 motor profile when multiple motors are controlled by a single drive or when a single motor is to be controlled by multiple profiles.</p>	<p>Direct Access Number — F449</p> <p>Parameter Type — Numerical</p> <p>Factory Default — 250.0</p> <p>Changeable During Run — Yes</p> <p>Minimum — 0.00</p> <p>Maximum — 250.0</p> <p>Units — %</p>
<p>Torque Limit Mode</p> <p>Program ⇒ Torque Setting Parameters ⇒ Torque Limit Settings ⇒ Torque Limit Mode</p> <p>Contact Toshiba's Marketing Department for information on this parameter.</p> <p>Settings:</p> <ul style="list-style-type: none"> Driving/Regen Positive/Negative 	<p>Direct Access Number — F450</p> <p>Parameter Type — Selection List</p> <p>Factory Default — Driving/Regen</p> <p>Changeable During Run — No</p>

<p>Torque Limit Mode (Speed Dependent)</p> <p>Program ⇒ Torque Setting Parameters ⇒ Torque Limit Settings ⇒ Torque Limit Mode (Speed Dependent)</p> <p>This parameter allows for either wide or very limited speed fluctuations while operating in the Torque Control mode.</p> <p>The ASD output follows the commanded speed when No Speed Cooperation is selected and has a very limited speed fluctuation range when Standard is selected.</p> <p>Settings:</p> <ul style="list-style-type: none"> Standard No Speed Cooperation 	<p>Direct Access Number — F451</p> <p>Parameter Type — Selection List</p> <p>Factory Default — Standard</p> <p>Changeable During Run — Yes</p>
<p>Continued Stall Until Trip During Power Operation</p> <p>Program ⇒ Protection Parameters ⇒ Stall ⇒ Continuing Stall Period</p> <p>This parameter allows the user to extend the Overvoltage Stall (F305) and the Overcurrent Stall (F017) time settings.</p>	<p>Direct Access Number — F452</p> <p>Parameter Type — Numerical</p> <p>Factory Default — 0.0</p> <p>Changeable During Run — Yes</p> <p>Minimum — 0.0</p> <p>Maximum — 1.00</p> <p>Units — Seconds</p>
<p>Stall Prevention During Regeneration</p> <p>Program ⇒ Protection Parameters ⇒ Stall ⇒ Stall Prevention During Regeneration</p> <p>This parameter Enables/Disables the Overvoltage Stall (F305) and the Overcurrent Stall (F017) function during regeneration <u>only</u>. Application-specific conditions may occur that warrant disabling the Stall function during regeneration.</p> <p>Settings:</p> <ul style="list-style-type: none"> With Stall Prevention Without Stall Prevention 	<p>Direct Access Number — F453</p> <p>Parameter Type — Selection List</p> <p>Factory Default — With Stall Prevention.</p> <p>Changeable During Run — Yes</p>
<p>Current Differential Gain</p> <p>Program ⇒ Special Control Parameters ⇒ Special Parameters ⇒ Current Differential Gain</p> <p>This parameter determines the degree that the current differential function affects the output signal. The larger the value entered here, the more pronounced the Current Differential Gain.</p>	<p>Direct Access Number — F454</p> <p>Parameter Type — Numerical</p> <p>Factory Default — 1.23</p> <p>Changeable During Run — Yes</p> <p>Minimum — 0.00</p> <p>Maximum — 327.6</p>
<p>VI/II Bias Adjust</p> <p>Program ⇒ Frequency Setting Parameters ⇒ Speed Reference Setpoints ⇒ VI/II ⇒ Bias</p> <p>This parameter is used to fine-tune the bias of the VI/II input terminals.</p> <p>Note: See note on pg. 50 for further information on the VI/II terminal.</p> <p>This setting may be used to ensure that the zero level of the input source (pot, pressure transducer, flow meter, etc.) is also the zero level setting of the ASD system.</p> <p>This is accomplished by setting the input source to zero and either increasing or decreasing this setting to provide an output of zero from the ASD.</p>	<p>Direct Access Number — F470</p> <p>Parameter Type — Numerical</p> <p>Factory Default — 100</p> <p>Changeable During Run — Yes</p> <p>Minimum — 0.0</p> <p>Maximum — 255</p>

VI/II Gain Adjust

Program ⇒ Frequency Setting Parameters ⇒ Speed Reference Setpoints ⇒ VI/II ⇒ **Gain**

This parameter is used to fine tune the gain of the **VI/II** input terminals.

Note: See note on pg. 50 for further information on the VI/II terminal.

This setting may be used to ensure that the 100% level of the input source (pot, pressure transducer, flow meter, etc.) is also the 100% level setting of the ASD system.

This is accomplished by setting the input source to 100% and either increasing or decreasing this setting to provide an output of 100% from the ASD.

Direct Access Number — F471

Parameter Type — **Numerical**

Factory Default — **50**

Changeable During Run — **Yes**

Minimum — 0.0

Maximum — 255

RR Bias Adjust

Program ⇒ Frequency Setting Parameters ⇒ Speed Reference Setpoints ⇒ RR ⇒ **Bias**

This parameter is used to fine tune the bias of the **RR** input terminal when this terminal is used as the control input while operating in the **Speed Control** or the **Torque Control** mode.

This setting may be used to ensure that the zero level of the input source (pot, pressure transducer, flow meter, etc.) is also the zero level setting of the ASD system.

This is accomplished by setting the input source to zero and either increasing or decreasing this setting to provide an output of zero from the ASD.

Direct Access Number — F472

Parameter Type — **Numerical**

Factory Default — **120**

Changeable During Run — **Yes**

Minimum — 0.0

Maximum — 255

RR Gain Adjust

Program ⇒ Frequency Setting Parameters ⇒ Speed Reference Setpoints ⇒ RR ⇒ **Gain**

This parameter is used to fine tune the gain of the **RR** input terminal when this terminal is used as the control input while operating in the **Speed Control** or the **Torque Control** mode.

This setting may be used to ensure that the 100% level of the input source (pot, pressure transducer, flow meter, etc.) is also the 100% level setting of the ASD system.

This is accomplished by setting the input source to 100% and either increasing or decreasing this setting to provide an output of 100% from the ASD.

Direct Access Number — F473

Parameter Type — **Numerical**

Factory Default — **61**

Changeable During Run — **Yes**

Minimum — 0.0

Maximum — 255

RX Bias Adjust

Program ⇒ Frequency Setting Parameters ⇒ Speed Reference Setpoints ⇒ RX ⇒ **Bias**

This parameter is used to fine tune the bias of the **RX** input terminal when this terminal is used as the control input while operating in the **Speed Control** or the **Torque Control** mode.

This setting may be used to ensure that the zero level of the input source (pot, pressure transducer, flow meter, etc.) is also the zero level setting of the ASD system.

This is accomplished by setting the input source to zero and either increasing or decreasing this setting to provide an output of zero from the ASD.

Direct Access Number — F474

Parameter Type — **Numerical**

Factory Default — **99**

Changeable During Run — **Yes**

Minimum — 0.0

Maximum — 255

<p>RX Gain Adjust</p> <p>Program ⇒ Frequency Setting Parameters ⇒ Speed Reference Setpoints ⇒ RX ⇒ Gain</p> <p>This parameter is used to fine tune the gain of the RX input terminal when this terminal is used as the control input while operating in the Speed Control or the Torque Control mode.</p> <p>This setting may be used to ensure that the 100% level of the input source (pot, pressure transducer, flow meter, etc.) is also the 100% level setting of the ASD system.</p> <p>This is accomplished by setting the input source to 100% and either increasing or decreasing this setting to provide an output of 100% from the ASD.</p>	<p>Direct Access Number — F475</p> <p>Parameter Type — Numerical</p> <p>Factory Default — 141</p> <p>Changeable During Run — Yes</p> <p>Minimum — 0.0</p> <p>Maximum — 255</p>
<p>RX2 Bias Adjust</p> <p>Program ⇒ Frequency Setting Parameters ⇒ Speed Reference Setpoints ⇒ RX2 ⇒ Bias</p> <p>This parameter is used to fine tune the bias of the RX2 input terminal when this terminal is used as the control input while operating in the Speed Control or the Torque Control mode.</p> <p>This setting may be used to ensure that the zero level of the input source (pot, pressure transducer, flow meter, etc.) is also the zero level setting of the ASD system.</p> <p>This is accomplished by setting the input source to zero and either increasing or decreasing this setting to provide a zero output from the ASD.</p>	<p>Direct Access Number — F476</p> <p>Parameter Type — Numerical</p> <p>Factory Default — 99</p> <p>Changeable During Run — Yes</p> <p>Minimum — 0.0</p> <p>Maximum — 255</p>
<p>RX2 Gain Adjust</p> <p>Program ⇒ Frequency Setting Parameters ⇒ Speed Reference Setpoints ⇒ RX2 ⇒ Gain</p> <p>This parameter is used to fine tune the gain of the RX2 input terminal when this terminal is used as the control input while operating in the Speed Control or the Torque Control mode.</p> <p>This setting may be used to ensure that the 100% level of the input source (pot, pressure transducer, flow meter, etc.) is also the 100% level setting of the ASD system.</p> <p>This is accomplished by setting the input source to 100% and either increasing or decreasing this setting to provide an output of 100% from the ASD.</p>	<p>Direct Access Number — F477</p> <p>Parameter Type — Numerical</p> <p>Factory Default — 141</p> <p>Changeable During Run — Yes</p> <p>Minimum — 0.0</p> <p>Maximum — 255</p>
<p>Exciting Strengthening Coefficient</p> <p>Program ⇒ Special Control Parameters ⇒ Special Parameters ⇒ Exciting Strengthening Coefficient</p> <p>This parameter determines the rate at which the excitation current is allowed to go from zero to saturation and is enabled at F481.</p>	<p>Direct Access Number — F480</p> <p>Parameter Type — Numerical</p> <p>Factory Default — 64</p> <p>Changeable During Run — Yes</p> <p>Minimum — 0</p> <p>Maximum — 255</p>

<p>Over Exciting Cooperation</p> <p>Program ⇒ Special Control Parameters ⇒ Special Parameters⇒ Over-Exciting Cooperation</p> <p>This parameter determines the method used to control the rate that the excitation current is allowed to reach saturation. If Effective is selected, the preset Torque Control or Speed Control settings will determine the rate that the motor reaches excitation saturation.</p> <p>Settings:</p> <p>Effective Applied by F480</p>	<p>Direct Access Number — F481</p> <p>Parameter Type — Selection List</p> <p>Factory Default — Effective</p> <p>Changeable During Run — Yes</p>
<p>Current Vector Control</p> <p>Program ⇒ Special Control Parameters ⇒ Special Parameters⇒ Control Margin Modulation ⇒ % Current Vector Control</p> <p>This parameter establishes the control margin of modulation when operating in the Current Vector Control mode.</p>	<p>Direct Access Number — F482</p> <p>Parameter Type — Numerical</p> <p>Factory Default — 90.0</p> <p>Changeable During Run — Yes</p> <p>Minimum — 80.0</p> <p>Maximum — 300.0</p> <p>Units — %</p>
<p>Voltage Vector Control</p> <p>Program ⇒ Special Control Parameters ⇒ Special Parameters⇒ Control Margin Modulation ⇒ % Voltage Vector Control</p> <p>This parameter establishes the control margin of modulation while operating in the Voltage Vector Control mode.</p>	<p>Direct Access Number — F483</p> <p>Parameter Type — Numerical</p> <p>Factory Default — 105.0</p> <p>Changeable During Run — Yes</p> <p>Minimum — 80.0</p> <p>Maximum — 300.0</p> <p>Units — %</p>
<p>Constant Vector Control</p> <p>Program ⇒ Special Control Parameters ⇒ Special Parameters⇒ Control Margin Modulation ⇒ % Voltage Vector Control</p> <p>This parameter establishes the control margin of modulation while operating in the Constant Vector Control mode.</p>	<p>Direct Access Number — F484</p> <p>Parameter Type — Numerical</p> <p>Factory Default — 105.0</p> <p>Changeable During Run — Yes</p> <p>Minimum — 80.0</p> <p>Maximum — 300.0</p> <p>Units — %</p>
<p>Stall Cooperation Gain at Field Weakening Zone</p> <p>Program ⇒ Special Control Parameters ⇒ Special Parameters⇒ Stall Cooperation Gain at Field Weakening Zone</p> <p>This parameter determines the degree that the Stall function is effective while operating the motor in the field weakening zone.</p>	<p>Direct Access Number — F485</p> <p>Parameter Type — Numerical</p> <p>Factory Default — 128</p> <p>Changeable During Run — Yes</p> <p>Minimum — 0</p> <p>Maximum — 255</p>
<p>Excitation Starting Rate</p> <p>Program ⇒ Special Control Parameters ⇒ Special Parameters⇒ Excitation Starting Rate</p> <p>This parameter establishes the rate of increase in the excitation current from a zero output of the ASD.</p>	<p>Direct Access Number — F486</p> <p>Parameter Type — Numerical</p> <p>Factory Default — 163.8</p> <p>Changeable During Run — Yes</p> <p>Minimum — 1.64</p> <p>Maximum — 327.6</p>

<p>Compensation Coefficient for Iron Loss</p> <p>Program ⇒ Special Control Parameters ⇒ Special Parameters⇒ Compensation Coefficient for Iron Loss</p> <p>This parameter compensates for losses in the rotor-to-stator coupling of the excitation and torque current energy.</p>	<p>Direct Access Number — F487</p> <p>Parameter Type — Numerical</p> <p>Factory Default — 105.0</p> <p>Changeable During Run — Yes</p> <p>Minimum — 0</p> <p>Maximum — 255</p>
<p>Voltage Compensation Coefficient for Dead Time</p> <p>Program ⇒ Special Control Parameters ⇒ Special Parameters⇒ Voltage Compensation Coefficient for Dead Time</p> <p>This parameter adjusts the degree of voltage compensation during dead time by increasing or decreasing the on-time of the programmed PWM just prior to the start of the dead time.</p>	<p>Direct Access Number — F488</p> <p>Parameter Type — Numerical</p> <p>Factory Default — 163.8</p> <p>Changeable During Run — Yes</p> <p>Minimum — 1.64</p> <p>Maximum — 327.6</p>
<p>Dead Time Compensation (Enable)</p> <p>Program ⇒ Special Control Parameters ⇒ Special Parameters⇒ Dead Time Compensation</p> <p>This parameter Enables/Disables the Dead Time Compensation function. The Dead Time Compensation feature provides a smoothing of the on-off IGBT signal that feeds the Gate Driver board during the off portion of the on-off cycle.</p> <p>Settings:</p> <ul style="list-style-type: none"> Enabled Disabled 	<p>Direct Access Number — F489</p> <p>Parameter Type — Selection List</p> <p>Factory Default — Enabled</p> <p>Changeable During Run — Yes</p>
<p>Dead-time Compensation Bias</p> <p>Program ⇒ Special Control Parameters ⇒ Special Parameters⇒ Dead-time Compensation Bias</p> <p>This parameter sets a bias for the Dead-time Compensation function. The Dead-time Compensation feature provides a smoothing of the on-off IGBT signal that feeds the Gate Driver board.</p>	<p>Direct Access Number — F490</p> <p>Parameter Type — Numerical</p> <p>Factory Default — 0.000</p> <p>Changeable During Run — Yes</p> <p>Minimum — -32.768</p> <p>Maximum — 32.767</p>
<p>Switching Frequency of Current/Voltage Control</p> <p>Program ⇒ Special Control Parameters ⇒ Special Parameters ⇒ Switching Frequency between Current and Voltage Control</p> <p>This parameter sets the threshold frequency at which ASD control is switched between Current-control and Voltage -control.</p>	<p>Direct Access Number — F491</p> <p>Parameter Type — Numerical</p> <p>Factory Default — 40.00</p> <p>Changeable During Run — Yes</p> <p>Minimum — 10.00</p> <p>Maximum — 60.00</p> <p>Units — Hz</p>

<p>Accel #2 Time</p> <p>Program ⇒ Special Control Parameters ⇒ #1 – #4 Settings</p> <p>This parameter specifies the time in seconds for the drive to go from 0.0 Hz to the Maximum Frequency for the #2 Acceleration profile. The accel/decel pattern may be set using F502. The minimum accel/decel time may be set using F508.</p> <p>This setting is also used to determine the acceleration rate of the Motorized Pot function.</p> <p><i>Note: An acceleration time shorter than the load will allow may cause nuisance tripping and mechanical stress to loads. Automatic Accel/Decel and Stall settings may lengthen the acceleration time.</i></p>	<p>Direct Access Number — F500</p> <p>Parameter Type — Numerical</p> <p>Factory Default — (ASD-dependent)</p> <p>Changeable During Run — Yes</p> <p>Minimum — 0.1</p> <p>Maximum — 6000</p> <p>Units — Seconds</p>
<p>Decel #2 Time</p> <p>Program ⇒ Special Control Parameters ⇒ Accel/Decel #1 – #4 Settings</p> <p>This parameter specifies the time in seconds for the drive to go from the Maximum Frequency to 0.0 Hz for the #2 Deceleration profile. The accel/decel pattern may be set using F502. The minimum accel/decel time may be set using F508.</p> <p>This setting is also used to determine the deceleration rate of the Motorized Pot function.</p> <p><i>Note: A deceleration time shorter than the load will allow may cause nuisance tripping and mechanical stress to loads. Automatic Accel/Decel and Stall settings may lengthen the acceleration time.</i></p>	<p>Direct Access Number — F501</p> <p>Parameter Type — Numerical</p> <p>Factory Default — (ASD-dependent)</p> <p>Changeable During Run — Yes</p> <p>Minimum — 0.1</p> <p>Maximum — 6000</p> <p>Units — Seconds</p>

Accel/Decel Pattern #1

Program ⇒ Special Control Parameters ⇒ **Accel/Decel #1 – #4 Settings**

This parameter enables a user-selected preprogrammed output profile that controls the acceleration and deceleration pattern for the **#1 Accel/Decel** parameter.

Settings:

- Linear
- S-Pattern 1
- S-Pattern 2

The figures below provide a profile of the available accel/decel patterns.

Linear acceleration and deceleration is the default pattern and is used on most applications.

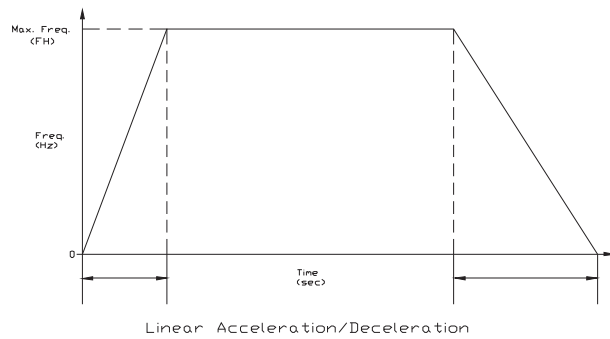

S-pattern 1 is used for applications that require quick acceleration and deceleration. This setting is also popular for applications that require shock absorption at the start of acceleration or deceleration.

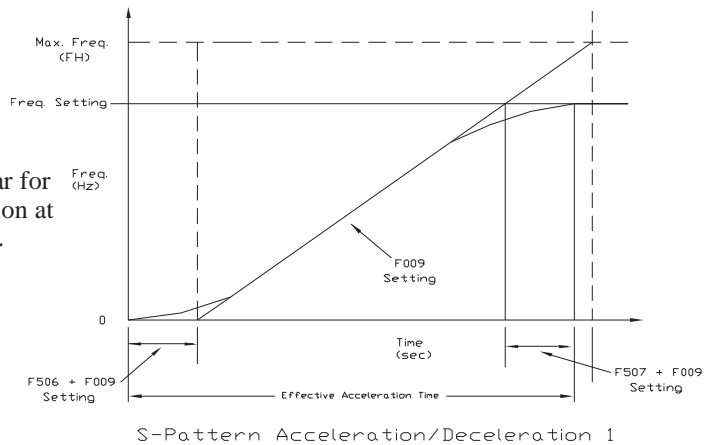

S-pattern 2 acceleration and deceleration decreases the rate of change above the base frequency.

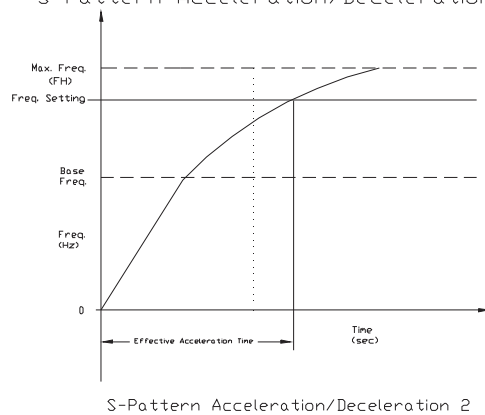

Direct Access Number — F502

Parameter Type — **Selection List**

Factory Default — **Linear**

Changeable During Run — **Yes**

<p>Accel/Decel Pattern #2</p> <p>Program ⇒ Special Control Parameters ⇒ 1 – #4 Settings</p> <p>This parameter enables a user-selected preprogrammed output profile that controls the acceleration and deceleration pattern for the #2 Accel/Decel parameter.</p> <p>Settings:</p> <ul style="list-style-type: none"> Linear S-Pattern 1 S-Pattern 2 	<p>Direct Access Number — F503</p> <p>Parameter Type — Selection List</p> <p>Factory Default — Linear</p> <p>Changeable During Run — Yes</p>
<p>Acc/Dec Group</p> <p>No path available (Direct Access Only)</p> <p>While operating using the LED Keypad Option this parameter selects the accel/decel profile to be used during a multiple-accel/decel profile configuration. The accel/decel setting for selections 1 – 4 may be found at F009, F500, F510, and F514, respectively.</p> <p>Settings:</p> <ul style="list-style-type: none"> Group 1 Group 2 Group 3 Group 4 <p><i>Note: If using the LCD EOI, press ESC from the Frequency Command screen to access this parameter.</i></p>	<p>Direct Access Number — F504</p> <p>Parameter Type — Selection List</p> <p>Factory Default — 1</p> <p>Changeable During Run — Yes</p>
<p>Acc/Dec Switching Frequency #1</p> <p>Program ⇒ Special Control Parameters ⇒ Accel/Decel Special</p> <p>This parameter sets the frequency at which the acceleration control is switched from the Accel #1 profile to the Accel #2 profile during a multiple-acceleration profile configuration.</p>	<p>Direct Access Number — F505</p> <p>Parameter Type — Numerical</p> <p>Factory Default — 0.00</p> <p>Changeable During Run — Yes</p> <p>Minimum — 0.00</p> <p>Maximum — Max. Freq. (F011)</p> <p>Units — Hz</p>
<p>S-Pattern Lower Limit Adjustment</p> <p>Program ⇒ Special Control Parameters ⇒ Accel/Decel Special</p> <p>Sets the lower limit of S-pattern 1 and 2.</p>	<p>Direct Access Number — F506</p> <p>Parameter Type — Numerical</p> <p>Factory Default — 25.00</p> <p>Changeable During Run — Yes</p> <p>Minimum — 0.00</p> <p>Maximum — 50.00</p> <p>Units — %</p>
<p>S-Pattern Upper Limit Adjustment</p> <p>Program ⇒ Special Control Parameters ⇒ Accel/Decel Special</p> <p>Sets the upper limit frequency of S-pattern 1 and 2.</p>	<p>Direct Access Number — F507</p> <p>Parameter Type — Numerical</p> <p>Factory Default — 25.00</p> <p>Changeable During Run — Yes</p> <p>Minimum — 0.00</p> <p>Maximum — 50.00</p> <p>Units — %</p>

<p>Accel/Decel Lower Limit Time</p> <p>Program ⇒ Special Control Parameters ⇒ Accel/Decel Special</p> <p>This parameter sets the lower limit of the Accel/Decel time.</p>	<p>Direct Access Number — F508</p> <p>Parameter Type — Numerical</p> <p>Factory Default — 0.10</p> <p>Changeable During Run — Yes</p> <p>Minimum — 0.01</p> <p>Maximum — 10.00</p> <p>Units — Seconds</p>
<p>Accel #3 Time</p> <p>Program ⇒ Special Control Parameters ⇒ Accel/Decel #1 – #4 Settings</p> <p>This parameter specifies the time in seconds for the drive to go from 0.0 Hz to the Maximum Frequency for the #3 Acceleration profile. The accel/decel pattern may be set using F502. The minimum accel/decel time may be set using F508.</p> <p><i>Note: An acceleration time shorter than the load will allow may cause nuisance tripping and mechanical stress to loads. Automatic Accel/Decel and Stall settings may lengthen the acceleration time.</i></p>	<p>Direct Access Number — F510</p> <p>Parameter Type — Numerical</p> <p>Factory Default — (ASD-dependent)</p> <p>Changeable During Run — Yes</p> <p>Minimum — 0.1</p> <p>Maximum — 6000</p> <p>Units — Seconds</p>
<p>Decel #3 Time</p> <p>Program ⇒ Special Control Parameters ⇒ Accel/Decel #1 – #4 Settings</p> <p>This parameter specifies the time in seconds for the drive to go from the Maximum Frequency to 0.0 Hz for the #3 Deceleration profile.</p> <p>The accel/decel pattern may be set using F502. The minimum accel/decel time may be set using F508.</p> <p><i>Note: A deceleration time shorter than the load will allow may cause nuisance tripping and mechanical stress to loads. Automatic Accel/Decel and Stall settings may lengthen the deceleration time.</i></p>	<p>Direct Access Number — F511</p> <p>Parameter Type — Numerical</p> <p>Factory Default — (ASD-dependent)</p> <p>Changeable During Run — Yes</p> <p>Minimum — 0.1</p> <p>Maximum — 6000</p> <p>Units — Seconds</p>
<p>Accel/Decel Pattern #3</p> <p>Program ⇒ Special Control Parameters ⇒ Accel/Decel #1 – #4 Settings</p> <p>This parameter enables a user-selected preprogrammed output profile that controls the acceleration and deceleration pattern for the #3 Accel/Decel parameter.</p> <p>Settings:</p> <ul style="list-style-type: none"> Linear S-Pattern 1 S-Pattern 2 	<p>Direct Access Number — F512</p> <p>Parameter Type — Selection List</p> <p>Factory Default — Linear</p> <p>Changeable During Run — Yes</p>

<p>Accel/Decel Switching Frequency #2</p> <p>Program ⇒ Special Control Parameters ⇒ Accel/Decel Special</p> <p>This parameter sets the frequency at which the acceleration control is switched from the Accel #2 profile to the Accel #3 profile during a multiple-acceleration profile configuration.</p>	<p>Direct Access Number — F513</p> <p>Parameter Type — Numerical</p> <p>Factory Default — 0.00</p> <p>Changeable During Run — Yes</p> <p>Minimum — 0.00</p> <p>Maximum — Max. Freq. (F011)</p> <p>Units — Hz</p>
<p>Accel #4 Time</p> <p>Program ⇒ Special Control Parameters ⇒ Accel/Decel #1 – #4 Settings</p> <p>This parameter specifies the time in seconds for the drive to go from 0.0 Hz to the Maximum Frequency for the #4 Acceleration profile. The accel/decel pattern may be set using F502. The minimum accel/decel time may be set using F508.</p> <p><i>Note: An acceleration time shorter than the load will allow may cause nuisance tripping and mechanical stress to loads. Automatic Accel/Decel and Stall settings may lengthen the acceleration time.</i></p>	<p>Direct Access Number — F514</p> <p>Parameter Type — Numerical</p> <p>Factory Default — (ASD-dependent)</p> <p>Changeable During Run — Yes</p> <p>Minimum — 0.1</p> <p>Maximum — 6000</p> <p>Units — Seconds</p>
<p>Decel #4 Time</p> <p>Program ⇒ Special Control Parameters ⇒ Accel/Decel #1 – #4 Settings</p> <p>This parameter specifies the time in seconds for the drive to go from the Maximum Frequency to 0.0 Hz for the #4 Deceleration profile. The accel/decel pattern may be set using F502. The minimum accel/decel time may be set using F508.</p> <p><i>Note: A deceleration time shorter than the load will allow may cause nuisance tripping and mechanical stress to loads. Automatic Accel/Decel and Stall settings may lengthen the deceleration time.</i></p>	<p>Direct Access Number — F515</p> <p>Parameter Type — Numerical</p> <p>Factory Default — (ASD-dependent)</p> <p>Changeable During Run — Yes</p> <p>Minimum — 0.1</p> <p>Maximum — 6000</p> <p>Units — Seconds</p>
<p>Accel/Decel Pattern #4</p> <p>Program ⇒ Special Control Parameters ⇒ Accel/Decel #1 – #4 Settings</p> <p>This parameter enables a user-selected preprogrammed output profile that controls the acceleration and deceleration pattern for the #4 Accel/Decel parameter.</p> <p>Settings:</p> <ul style="list-style-type: none"> Linear S-Pattern 1 S-Pattern 2 	<p>Direct Access Number — F516</p> <p>Parameter Type — Selection List</p> <p>Factory Default — Linear</p> <p>Changeable During Run — Yes</p>

Accel/Decel Switching Frequency #3

Program ⇒ Special Control Parameters ⇒ **Accel/Decel Special**

This parameter sets the frequency at which the acceleration control is switched from the **Accel #3** profile to the **Accel #4** profile during a multiple-acceleration profile configuration.

Direct Access Number — F517

Parameter Type — **Numerical**

Factory Default — **0.00**

Changeable During Run — **Yes**

Minimum — 0.00

Maximum — **Max. Freq. (F011)**

Units — Hz

Pattern Run

Program ⇒ Pattern Run Control Parameters ⇒ **Pattern Run**

This parameter **Enables/Disables** the **Pattern Run** mode. When enabled, this feature allows up to 15 **Preset Speeds** to be run sequentially for a user-determined duration and number of times.

Direct Access Number — F520

Parameter Type — **Check Box**

Factory Default — **Disabled**

Changeable During Run — **No**

Settings:

Disabled

Enabled (box checked)

Pattern Run Description

User-defined **Preset Speeds** are labeled 1 – 15 (see **F018**). The ID number of any one of the fifteen frequencies (1 – 15) may be entered into the **Speed #** field of the **Pattern Run** screen and run for the number of times entered into the **Repeat** field (see **F530**). The execution of grouped **Preset Speeds** in this manner is called a **Pattern Run**.

Skip may be selected to ignore a **Speed #** field.

Pattern Run Setup

1. Configure an unused discrete input terminal for **Pattern #1** (2, 3, or 4). This terminal will initiate the selected **Pattern Run**. The input terminal settings may be configured via Program ⇒ Terminal Selection Parameters ⇒ **Input Terminals** (see [Table 5 on pg. 162](#) for available input terminal settings).
2. Enable the **Pattern Run** mode of operation via Program ⇒ Pattern Run Control Parameters ⇒ Pattern Run ⇒ **Enable/Disable** (check box).
3. Configure the **Preset Speeds** that are to be used as the **Group Speed** set of frequencies via Program ⇒ Pattern Run Control Parameters ⇒ **Preset Speeds** (e.g., [Preset Speed #1 on pg. 52](#)).
4. Configure the **Group Speeds** by associating the **Preset Speeds** that are to be enabled and grouped (from step 3) as **Group Speed 1** (2, 3, or 4) via Program ⇒ Pattern Run Control Parameters ⇒ **Speeds**. Set the **Repeat** field to the number of times that the selected group is to be run. Set unused speed settings to **Skip**.
5. From the **Remote** mode (**Local|Remote** LED is off), initiate a **Run** command (e.g., **F** and/or **R** terminal **On**).
6. Connect the input terminal that was configured in step 1 to **CC** and the **Pattern Run** will start and continue as programmed. Open the connection to stop the **Pattern Run** before its conclusion.

See [F018 on pg. 52](#) for further information on this parameter.

<p>Pattern Run Mode Restart Command</p> <p>Program ⇒ Pattern Run Control Parameters ⇒ Pattern Run</p> <p>This parameter sets the start condition of subsequent Pattern Runs after the initial Pattern Run has been terminated or has completed its programming.</p> <p>Settings:</p> <ul style="list-style-type: none"> Reset Continue 	<p>Direct Access Number — F521</p> <p>Parameter Type — Selection List</p> <p>Factory Default — Disabled</p> <p>Changeable During Run — No</p>
<p>Group #1 Speed Repeat Factor</p> <p>Program ⇒ Pattern Run Control Parameters ⇒ Speeds</p> <p>This parameter sets the number of times that the pattern defined in Group #1 will be run.</p>	<p>Direct Access Number — F530</p> <p>Parameter Type — Numerical</p> <p>Factory Default — 1</p> <p>Changeable During Run — No</p> <p>Minimum — 1</p> <p>Maximum — Infinite</p>
<p>Group #1 Speed #1 (Pattern Run)</p> <p>Program ⇒ Pattern Run Control Parameters ⇒ Speeds</p> <p>Up to four groups of Preset Speeds may be setup and run from this screen. The Preset Speed numbers (1 – 15) may be entered into the Speed # field to be run for the number of times entered into the Repeat field (0 – 254) or forever by selecting Infinite. Running multiple Preset Speeds as a group is called a Pattern Run.</p> <p>This parameter allows the user to run the Preset Speeds 1 – 15 as a group and is identified as Group #1.</p> <p>Skip may be selected to ignore a Preset Speed entry.</p> <p>See F520 for further information on this setting.</p>	<p>Direct Access Number — F531</p> <p>Parameter Type — Selection List</p> <p>Factory Default — 1</p> <p>Changeable During Run — No</p>
<p>Group #1 Speed #2</p> <p>Program ⇒ Pattern Run Control Parameters ⇒ Speeds</p> <p>Same as #1 Group Speed #1 (see F531).</p>	<p>Direct Access Number — F532</p> <p>Parameter Type — Selection List</p> <p>Factory Default — 2</p> <p>Changeable During Run — No</p>
<p>Group #1 Speed #3</p> <p>Program ⇒ Pattern Run Control Parameters ⇒ Speeds</p> <p>Same as #1 Group Speed #1 (see F531).</p>	<p>Direct Access Number — F533</p> <p>Parameter Type — Selection List</p> <p>Factory Default — 3</p> <p>Changeable During Run — No</p>
<p>Group #1 Speed #4</p> <p>Program ⇒ Pattern Run Control Parameters ⇒ Speeds</p> <p>Same as #1 Group Speed #1 (see F531).</p>	<p>Direct Access Number — F534</p> <p>Parameter Type — Selection List</p> <p>Factory Default — 4</p> <p>Changeable During Run — No</p>
<p>Group #1 Speed #5</p> <p>Program ⇒ Pattern Run Control Parameters ⇒ Speeds</p> <p>Same as #1 Group Speed #1 (see F531).</p>	<p>Direct Access Number — F535</p> <p>Parameter Type — Selection List</p> <p>Factory Default — 5</p> <p>Changeable During Run — No</p>

<p>Group #1 Speed #6</p> <p>Program ⇒ Pattern Run Control Parameters ⇒ Speeds</p> <p>Same as #1 Group Speed #1 (see F531).</p>	<p>Direct Access Number — F536</p> <p>Parameter Type — Selection List</p> <p>Factory Default — 6</p> <p>Changeable During Run — No</p>
<p>Group #1 Speed #7</p> <p>Program ⇒ Pattern Run Control Parameters ⇒ Speeds</p> <p>Same as #1 Group Speed #1 (see F531).</p>	<p>Direct Access Number — F537</p> <p>Parameter Type — Selection List</p> <p>Factory Default — 7</p> <p>Changeable During Run — No</p>
<p>Group #1 Speed #8</p> <p>Program ⇒ Pattern Run Control Parameters ⇒ Speeds</p> <p>Same as #1 Group Speed #1 (see F531).</p>	<p>Direct Access Number — F538</p> <p>Parameter Type — Selection List</p> <p>Factory Default — 8</p> <p>Changeable During Run — No</p>
<p>Group #2 Speed Repeat Factor</p> <p>Program ⇒ Pattern Run Control Parameters ⇒ Speeds</p> <p>This parameter sets the number of times that the enabled preset speeds of Group #2 will be run; 0 – 254 or Infinite.</p>	<p>Direct Access Number — F540</p> <p>Parameter Type — Selection List</p> <p>Factory Default — 1</p> <p>Changeable During Run — No</p>
<p>Group #2 Speed #1</p> <p>Program ⇒ Pattern Run Control Parameters ⇒ Speeds</p> <p>Same as #1 Group Speed #1 (see F531).</p>	<p>Direct Access Number — F541</p> <p>Parameter Type — Selection List</p> <p>Factory Default — 9</p> <p>Changeable During Run — No</p>
<p>Group #2 Speed #2</p> <p>Program ⇒ Pattern Run Control Parameters ⇒ Speeds</p> <p>Same as #1 Group Speed #1 (see F531).</p>	<p>Direct Access Number — F542</p> <p>Parameter Type — Selection List</p> <p>Factory Default — 10</p> <p>Changeable During Run — No</p>
<p>Group #2 Speed #3</p> <p>Program ⇒ Pattern Run Control Parameters ⇒ Speeds</p> <p>Same as #1 Group Speed #1 (see F531).</p>	<p>Direct Access Number — F543</p> <p>Parameter Type — Selection List</p> <p>Factory Default — 11</p> <p>Changeable During Run — No</p>
<p>Group #2 Speed #4</p> <p>Program ⇒ Pattern Run Control Parameters ⇒ Speeds</p> <p>Same as #1 Group Speed #1 (see F531).</p>	<p>Direct Access Number — F544</p> <p>Parameter Type — Selection List</p> <p>Factory Default — 12</p> <p>Changeable During Run — No</p>
<p>Group #2 Speed #5</p> <p>Program ⇒ Pattern Run Control Parameters ⇒ Speeds</p> <p>Same as #1 Group Speed #1 (see F531).</p>	<p>Direct Access Number — F545</p> <p>Parameter Type — Selection List</p> <p>Factory Default — 13</p> <p>Changeable During Run — No</p>
<p>Group #2 Speed #6</p> <p>Program ⇒ Pattern Run Control Parameters ⇒ Speeds</p> <p>Same as #1 Group Speed #1 (see F531).</p>	<p>Direct Access Number — F546</p> <p>Parameter Type — Selection List</p> <p>Factory Default — 14</p> <p>Changeable During Run — No</p>

<p>Group #2 Speed #7</p> <p>Program ⇒ Pattern Run Control Parameters ⇒ Speeds</p> <p>Same as #1 Group Speed #1 (see F531).</p>	<p>Direct Access Number — F547</p> <p>Parameter Type — Selection List</p> <p>Factory Default — 15</p> <p>Changeable During Run — No</p>
<p>Group #2 Speed #8</p> <p>Program ⇒ Pattern Run Control Parameters ⇒ Speeds</p> <p>Same as #1 Group Speed #1 (see F531).</p>	<p>Direct Access Number — F548</p> <p>Parameter Type — Selection List</p> <p>Factory Default — Skip</p> <p>Changeable During Run — No</p>
<p>Group #3 Speed Repeat Factor</p> <p>Program ⇒ Pattern Run Control Parameters ⇒ Speeds</p> <p>This parameter sets the number of times that the enabled preset speeds of Group #3 will be run; 0 – 254 or Infinite.</p>	<p>Direct Access Number — F550</p> <p>Parameter Type — Selection List</p> <p>Factory Default — 1</p> <p>Changeable During Run — No</p>
<p>Group #3 Speed #1</p> <p>Program ⇒ Pattern Run Control Parameters ⇒ Speeds</p> <p>Same as #1 Group Speed #1 (see F531).</p>	<p>Direct Access Number — F551</p> <p>Parameter Type — Selection List</p> <p>Factory Default — 1</p> <p>Changeable During Run — No</p>
<p>Group #3 Speed #2</p> <p>Program ⇒ Pattern Run Control Parameters ⇒ Speeds</p> <p>Same as #1 Group Speed #1 (see F531).</p>	<p>Direct Access Number — F552</p> <p>Parameter Type — Selection List</p> <p>Factory Default — 2</p> <p>Changeable During Run — No</p>
<p>Group #3 Speed #3</p> <p>Program ⇒ Pattern Run Control Parameters ⇒ Speeds</p> <p>Same as #1 Group Speed #1 (see F531).</p>	<p>Direct Access Number — F553</p> <p>Parameter Type — Selection List</p> <p>Factory Default — 3</p> <p>Changeable During Run — No</p>
<p>Group #3 Speed #4</p> <p>Program ⇒ Pattern Run Control Parameters ⇒ Speeds</p> <p>Same as #1 Group Speed #1 (see F531).</p>	<p>Direct Access Number — F554</p> <p>Parameter Type — Selection List</p> <p>Factory Default — 4</p> <p>Changeable During Run — No</p>
<p>Group #3 Speed #5</p> <p>Program ⇒ Pattern Run Control Parameters ⇒ Speeds</p> <p>Same as #1 Group Speed #1 (see F531).</p>	<p>Direct Access Number — F555</p> <p>Parameter Type — Selection List</p> <p>Factory Default — 5</p> <p>Changeable During Run — No</p>
<p>Group #3 Speed #6</p> <p>Program ⇒ Pattern Run Control Parameters ⇒ Speeds</p> <p>Same as #1 Group Speed #1 (see F531).</p>	<p>Direct Access Number — F556</p> <p>Parameter Type — Selection List</p> <p>Factory Default — 6</p> <p>Changeable During Run — No</p>
<p>Group #3 Speed #7</p> <p>Program ⇒ Pattern Run Control Parameters ⇒ Speeds</p> <p>Same as #1 Group Speed #1 (see F531).</p>	<p>Direct Access Number — F557</p> <p>Parameter Type — Selection List</p> <p>Factory Default — 7</p> <p>Changeable During Run — No</p>

<p>Group #3 Speed #8</p> <p>Program ⇒ Pattern Run Control Parameters ⇒ Speeds</p> <p>Same as #1 Group Speed #1 (see F531).</p>	<p>Direct Access Number — F558</p> <p>Parameter Type — Selection List</p> <p>Factory Default — 8</p> <p>Changeable During Run — No</p>
<p>Group #4 Speed Repeat Factor</p> <p>Program ⇒ Pattern Run Control Parameters ⇒ Speeds</p> <p>This parameter sets the number of times that the enabled preset speeds of Group #4 will be run; 1 – 254 or Infinite.</p>	<p>Direct Access Number — F560</p> <p>Parameter Type — Selection List</p> <p>Factory Default — 1</p> <p>Changeable During Run — No</p>
<p>Group #4 Speed #1</p> <p>Program ⇒ Pattern Run Control Parameters ⇒ Speeds</p> <p>Same as #1 Group Speed #1 (see F531).</p>	<p>Direct Access Number — F561</p> <p>Parameter Type — Selection List</p> <p>Factory Default — 9</p> <p>Changeable During Run — No</p>
<p>Group #4 Speed #2</p> <p>Program ⇒ Pattern Run Control Parameters ⇒ Speeds</p> <p>Same as #1 Group Speed #1 (see F531).</p>	<p>Direct Access Number — F562</p> <p>Parameter Type — Selection List</p> <p>Factory Default — 10</p> <p>Changeable During Run — No</p>
<p>Group #4 Speed #3</p> <p>Program ⇒ Pattern Run Control Parameters ⇒ Speeds</p> <p>Same as #1 Group Speed #1 (see F531).</p>	<p>Direct Access Number — F563</p> <p>Parameter Type — Selection List</p> <p>Factory Default — 11</p> <p>Changeable During Run — No</p>
<p>Group #4 Speed #4</p> <p>Program ⇒ Pattern Run Control Parameters ⇒ Speeds</p> <p>Same as #1 Group Speed #1 (see F531).</p>	<p>Direct Access Number — F564</p> <p>Parameter Type — Selection List</p> <p>Factory Default — 12</p> <p>Changeable During Run — No</p>
<p>Group #4 Speed #5</p> <p>Program ⇒ Pattern Run Control Parameters ⇒ Speeds</p> <p>Same as #1 Group Speed #1 (see F531).</p>	<p>Direct Access Number — F565</p> <p>Parameter Type — Selection List</p> <p>Factory Default — 13</p> <p>Changeable During Run — No</p>
<p>Group #4 Speed #6</p> <p>Program ⇒ Pattern Run Control Parameters ⇒ Speeds</p> <p>Same as #1 Group Speed #1 (see F531).</p>	<p>Direct Access Number — F566</p> <p>Parameter Type — Selection List</p> <p>Factory Default — 14</p> <p>Changeable During Run — No</p>
<p>Group #4 Speed #7</p> <p>Program ⇒ Pattern Run Control Parameters ⇒ Speeds</p> <p>Same as #1 Group Speed #1 (see F531).</p>	<p>Direct Access Number — F567</p> <p>Parameter Type — Selection List</p> <p>Factory Default — 15</p> <p>Changeable During Run — No</p>
<p>Group #4 Speed #8</p> <p>Program ⇒ Pattern Run Control Parameters ⇒ Speeds</p> <p>Same as #1 Group Speed #1 (see F531).</p>	<p>Direct Access Number — F568</p> <p>Parameter Type — Selection List</p> <p>Factory Default — Skip</p> <p>Changeable During Run — No</p>

<p>Pattern #1 Characteristics (Pattern Run) Program ⇒ Pattern Run Control Parameters ⇒ Preset Speeds ⇒ 1</p> <p>In conjunction with the setting of F585, this parameter is used to set the run-time of Preset Speed 1 when used as part of a Pattern Run.</p> <p>Settings:</p> <ul style="list-style-type: none"> Time From Start Time From Reach No Limit Until Next Step 	<p>Direct Access Number — F570 Parameter Type — Selection List Factory Default — Time From Start Changeable During Run — No</p>
<p>Pattern #2 Characteristics (Pattern Run) Program ⇒ Pattern Run Control Parameters ⇒ Preset Speeds ⇒ 2</p> <p>Same as #1 Pattern Characteristics (see F570).</p>	<p>Direct Access Number — F571 Parameter Type — Selection List Factory Default — Time From Start Changeable During Run — No</p>
<p>Pattern #3 Characteristics (Pattern Run) Program ⇒ Pattern Run Control Parameters ⇒ Preset Speeds ⇒ 3</p> <p>Same as #1 Pattern Characteristics (see F570).</p>	<p>Direct Access Number — F572 Parameter Type — Selection List Factory Default — Time From Start Changeable During Run — No</p>
<p>Pattern #4 Characteristics (Pattern Run) Program ⇒ Pattern Run Control Parameters ⇒ Preset Speeds ⇒ 4</p> <p>Same as #1 Pattern Characteristics (see F570).</p>	<p>Direct Access Number — F573 Parameter Type — Selection List Factory Default — Time From Start Changeable During Run — No</p>
<p>Pattern #5 Characteristics (Pattern Run) Program ⇒ Pattern Run Control Parameters ⇒ Preset Speeds ⇒ 5</p> <p>Same as #1 Pattern Characteristics (see F570).</p>	<p>Direct Access Number — F574 Parameter Type — Selection List Factory Default — Time From Start Changeable During Run — No</p>
<p>Pattern #6 Characteristics (Pattern Run) Program ⇒ Pattern Run Control Parameters ⇒ Preset Speeds ⇒ 6</p> <p>Same as #1 Pattern Characteristics (see F570).</p>	<p>Direct Access Number — F575 Parameter Type — Selection List Factory Default — Time From Start Changeable During Run — No</p>
<p>Pattern #7 Characteristics (Pattern Run) Program ⇒ Pattern Run Control Parameters ⇒ Preset Speeds ⇒ 7</p> <p>Same as #1 Pattern Characteristics (see F570).</p>	<p>Direct Access Number — F576 Parameter Type — Selection List Factory Default — Time From Start Changeable During Run — No</p>
<p>Pattern #8 Characteristics (Pattern Run) Program ⇒ Pattern Run Control Parameters ⇒ Preset Speeds ⇒ 8</p> <p>Same as #1 Pattern Characteristics (see F570).</p>	<p>Direct Access Number — F577 Parameter Type — Selection List Factory Default — Time From Start Changeable During Run — No</p>
<p>Pattern #9 Characteristics (Pattern Run) Program ⇒ Pattern Run Control Parameters ⇒ Preset Speeds ⇒ 9</p> <p>Same as #1 Pattern Characteristics (see F570).</p>	<p>Direct Access Number — F578 Parameter Type — Selection List Factory Default — Time From Start Changeable During Run — No</p>

<p>Pattern #10 Characteristics (Pattern Run) Program ⇒ Pattern Run Control Parameters ⇒ Preset Speeds ⇒ 10</p> <p>Same as #1 Pattern Characteristics (see F570).</p>	<p>Direct Access Number — F579 Parameter Type — Selection List Factory Default — Time From Start Changeable During Run — No</p>
<p>Pattern #11 Characteristics (Pattern Run) Program ⇒ Pattern Run Control Parameters ⇒ Preset Speeds ⇒ 11</p> <p>Same as #1 Pattern Characteristics (see F570).</p>	<p>Direct Access Number — F580 Parameter Type — Selection List Factory Default — Time From Start Changeable During Run — No</p>
<p>Pattern #12 Characteristics (Pattern Run) Program ⇒ Pattern Run Control Parameters ⇒ Preset Speeds ⇒ 12</p> <p>Same as #1 Pattern Characteristics (see F570).</p>	<p>Direct Access Number — F581 Parameter Type — Selection List Factory Default — Time From Start Changeable During Run — No</p>
<p>Pattern #13 Characteristics (Pattern Run) Program ⇒ Pattern Run Control Parameters ⇒ Preset Speeds ⇒ 13</p> <p>Same as #1 Pattern Characteristics (see F570).</p>	<p>Direct Access Number — F582 Parameter Type — Selection List Factory Default — Time From Start Changeable During Run — No</p>
<p>Pattern #14 Characteristics (Pattern Run) Program ⇒ Pattern Run Control Parameters ⇒ Preset Speeds ⇒ 14</p> <p>Same as #1 Pattern Characteristics (see F570).</p>	<p>Direct Access Number — F583 Parameter Type — Selection List Factory Default — Time From Start Changeable During Run — No</p>
<p>Pattern #15 Characteristics (Pattern Run) Program ⇒ Pattern Run Control Parameters ⇒ Preset Speeds ⇒ 15</p> <p>Same as #1 Pattern Characteristics (see F570).</p>	<p>Direct Access Number — F584 Parameter Type — Selection List Factory Default — Time From Start Changeable During Run — No</p>
<p>Pattern Run #1 Run-Time Setting Program ⇒ Pattern Run Control Parameters ⇒ Preset Speeds ⇒ 1</p> <p>This parameter sets the run-time value for the #1 Preset Speed mode when used as part of a Pattern Run.</p>	<p>Direct Access Number — F585 Parameter Type — Numerical Factory Default — 5 Changeable During Run — No Minimum — 1 Maximum — 8000 Units — Seconds</p>
<p>Pattern Run #2 Continuation Mode Run-Time Setting Program ⇒ Pattern Run Control Parameters ⇒ Preset Speeds ⇒ 2</p> <p>This parameter sets the run-time value for the #2 Preset Speed mode when used as part of a Pattern Run.</p>	<p>Direct Access Number — F586 Parameter Type — Numerical Factory Default — 5 Changeable During Run — No Minimum — 1 Maximum — 8000 Units — Seconds</p>

<p>Pattern Run #3 Run-Time Setting</p> <p>Program ⇒ Pattern Run Control Parameters ⇒ Preset Speeds ⇒ 3</p> <p>This parameter sets the run-time value for the #3 Preset Speed mode when used as part of a Pattern Run.</p>	<p>Direct Access Number — F587</p> <p>Parameter Type — Numerical</p> <p>Factory Default — 5</p> <p>Changeable During Run — No</p> <p>Minimum — 1</p> <p>Maximum — 8000</p> <p>Units — Seconds</p>
<p>Pattern Run #4 Run-Time Setting</p> <p>Program ⇒ Pattern Run Control Parameters ⇒ Preset Speeds ⇒ 4</p> <p>This parameter sets the run-time value for the #4 Preset Speed mode when used as part of a Pattern Run.</p>	<p>Direct Access Number — F588</p> <p>Parameter Type — Numerical</p> <p>Factory Default — 5</p> <p>Changeable During Run — No</p> <p>Minimum — 1</p> <p>Maximum — 8000</p> <p>Units — Seconds</p>
<p>Pattern Run #5 Run-Time Setting</p> <p>Program ⇒ Pattern Run Control Parameters ⇒ Preset Speeds ⇒ 5</p> <p>This parameter sets the run-time value for the #5 Preset Speed mode when used as part of a Pattern Run.</p>	<p>Direct Access Number — F589</p> <p>Parameter Type — Numerical</p> <p>Factory Default — 5</p> <p>Changeable During Run — No</p> <p>Minimum — 1</p> <p>Maximum — 8000</p> <p>Units — Seconds</p>
<p>Pattern Run #6 Run-Time Setting</p> <p>Program ⇒ Pattern Run Control Parameters ⇒ Preset Speeds ⇒ 6</p> <p>This parameter sets the run-time value for the #6 Preset Speed mode when used as part of a Pattern Run.</p>	<p>Direct Access Number — F590</p> <p>Parameter Type — Numerical</p> <p>Factory Default — 5</p> <p>Changeable During Run — No</p> <p>Minimum — 1</p> <p>Maximum — 8000</p> <p>Units — Seconds</p>
<p>Pattern Run #7 Run-Time Setting</p> <p>Program ⇒ Pattern Run Control Parameters ⇒ Preset Speeds ⇒ 7</p> <p>This parameter sets the run-time value for the #7 Preset Speed mode when used as part of a Pattern Run.</p>	<p>Direct Access Number — F591</p> <p>Parameter Type — Numerical</p> <p>Factory Default — 5</p> <p>Changeable During Run — No</p> <p>Minimum — 1</p> <p>Maximum — 8000</p> <p>Units — Seconds</p>
<p>Pattern Run #8 Run-Time Setting</p> <p>Program ⇒ Pattern Run Control Parameters ⇒ Preset Speeds ⇒ 8</p> <p>This parameter sets the run-time value for the #8 Preset Speed mode when used as part of a Pattern Run.</p>	<p>Direct Access Number — F592</p> <p>Parameter Type — Numerical</p> <p>Factory Default — 5</p> <p>Changeable During Run — No</p> <p>Minimum — 1</p> <p>Maximum — 8000</p> <p>Units — Seconds</p>

<p>Pattern Run #9 Run-Time Setting</p> <p>Program ⇒ Pattern Run Control Parameters ⇒ Preset Speeds ⇒ 9</p> <p>This parameter sets the run-time value for the #9 Preset Speed mode when used as part of a Pattern Run.</p>	<p>Direct Access Number — F593</p> <p>Parameter Type — Numerical</p> <p>Factory Default — 5</p> <p>Changeable During Run — No</p> <p>Minimum — 1</p> <p>Maximum — 8000</p> <p>Units — Seconds</p>
<p>Pattern Run #10 Run-Time Setting</p> <p>Program ⇒ Pattern Run Control Parameters ⇒ Preset Speeds ⇒ 10</p> <p>This parameter sets the run-time value for the #10 Preset Speed mode when used as part of a Pattern Run.</p>	<p>Direct Access Number — F594</p> <p>Parameter Type — Numerical</p> <p>Factory Default — 5</p> <p>Changeable During Run — No</p> <p>Minimum — 1</p> <p>Maximum — 8000</p> <p>Units — Seconds</p>
<p>Pattern Run #11 Run-Time Setting</p> <p>Program ⇒ Pattern Run Control Parameters ⇒ Preset Speeds ⇒ 11</p> <p>This parameter sets the run-time value for the #11 Preset Speed mode when used as part of a Pattern Run.</p>	<p>Direct Access Number — F595</p> <p>Parameter Type — Numerical</p> <p>Factory Default — 5</p> <p>Changeable During Run — No</p> <p>Minimum — 1</p> <p>Maximum — 8000</p> <p>Units — Seconds</p>
<p>Pattern Run #12 Run-Time Setting</p> <p>Program ⇒ Pattern Run Control Parameters ⇒ Preset Speeds ⇒ 12</p> <p>This parameter sets the run-time value for the #12 Preset Speed mode when used as part of a Pattern Run.</p>	<p>Direct Access Number — F596</p> <p>Parameter Type — Numerical</p> <p>Factory Default — 5</p> <p>Changeable During Run — No</p> <p>Minimum — 1</p> <p>Maximum — 8000</p> <p>Units — Seconds</p>
<p>Pattern Run #13 Run-Time Setting</p> <p>Program ⇒ Pattern Run Control Parameters ⇒ Preset Speeds ⇒ 13</p> <p>This parameter sets the run-time value for the #13 Preset Speed mode when used as part of a Pattern Run.</p>	<p>Direct Access Number — F597</p> <p>Parameter Type — Numerical</p> <p>Factory Default — 5</p> <p>Changeable During Run — No</p> <p>Minimum — 1</p> <p>Maximum — 8000</p> <p>Units — Seconds</p>
<p>Pattern Run #14 Run-Time Setting</p> <p>Program ⇒ Pattern Run Control Parameters ⇒ Preset Speeds ⇒ 14</p> <p>This parameter sets the run-time value for the #14 Preset Speed mode when used as part of a Pattern Run.</p>	<p>Direct Access Number — F598</p> <p>Parameter Type — Numerical</p> <p>Factory Default — 5</p> <p>Changeable During Run — No</p> <p>Minimum — 1</p> <p>Maximum — 8000</p> <p>Units — Seconds</p>

<p>Pattern Run #15 Run-Time Setting</p> <p>Program ⇒ Pattern Run Control Parameters ⇒ Preset Speeds ⇒ 15</p> <p>This parameter sets the run-time value for the #15 Preset Speed mode when used as part of a Pattern Run.</p>	<p>Direct Access Number — F599</p> <p>Parameter Type — Numerical</p> <p>Factory Default — 5</p> <p>Changeable During Run — No</p> <p>Minimum — 1</p> <p>Maximum — 8000</p> <p>Units — Seconds</p>
<p>Electronic Thermal Protection #1</p> <p>Program ⇒ Motor Parameters ⇒ Motor Set #1</p> <p>The Motor #1 Electronic Thermal Protection parameter specifies the motor overload current level for motor set #1. This value is entered as either a percentage of the full load rating of the ASD or as the FLA of the motor.</p> <p>The unit of measurement for this parameter may be set to Amps or it may be set as a percentage of the ASD rating. The name-plated FLA of the motor may be entered directly when Amps is selected as the unit of measurement (see F701 to change the display unit).</p> <p>Electronic Thermal Protection settings (#1 – #4) will be displayed in Amps if the EOI display units are set to V/A rather than %.</p>	<p>Direct Access Number — F600</p> <p>Parameter Type — Numerical</p> <p>Factory Default — 100.0</p> <p>Changeable During Run — Yes</p> <p>Minimum — 10.0</p> <p>Maximum — 100.0</p> <p>Units — %</p>
<p>Overcurrent Stall Level</p> <p>Program ⇒ Protection Parameters ⇒ Stall</p> <p>This parameter specifies the output current level at which the output frequency is reduced in an attempt to prevent a trip. The overcurrent level is entered as a percentage of the maximum rating of the drive.</p> <p><i>Note: Parameter F017 (Soft Stall) must be enabled to use this feature.</i></p>	<p>Direct Access Number — F601</p> <p>Parameter Type — Numerical</p> <p>Factory Default — (ASD-dependent)</p> <p>Changeable During Run — Yes</p> <p>Minimum — 0.00</p> <p>Maximum — 200.0</p> <p>Units — %</p>
<p>Trip Save at Power Down Enable</p> <p>Program ⇒ Protection Parameters ⇒ Trip Settings</p> <p>This parameter Enables/Disables the Trip Save at Power Down setting. When enabled, this feature logs the trip event and retains the trip information when the system powers down. The trip information may be viewed from the Monitor screen.</p> <p>When disabled, the trip information will be cleared when the system powers down.</p> <p>Settings:</p> <ul style="list-style-type: none"> Disabled Enabled (box checked) 	<p>Direct Access Number — F602</p> <p>Parameter Type — Check Box</p> <p>Factory Default — Disabled</p> <p>Changeable During Run — No</p>

<p>Emergency Off Mode Settings</p> <p>Program ⇒ Protection Parameters ⇒ Emergency Off Settings</p> <p>This parameter determines the method used to stop the motor in the event that an Emergency Off command is received and the system is configured to use this feature.</p> <p>This setting may also be associated with the FL terminals to allow the FL relay to change states when an EOFF condition occurs by setting the FL terminal to Fault FL (all) (see F132).</p> <p><i>Note:</i> A supplemental emergency stopping system should be used with the ASD. Emergency stopping should not be a task of the ASD alone.</p> <p>Settings:</p> <ul style="list-style-type: none"> Coast Stop Deceleration Stop DC Injection Braking Stop 	<p>Direct Access Number — F603</p> <p>Parameter Type — Selection List</p> <p>Factory Default — Coast Stop</p> <p>Changeable During Run — No</p>
<p>Emergency Off DC Injection Application Time</p> <p>Program ⇒ Protection Parameters ⇒ Emergency Off Settings</p> <p>When DC Injection is used as a function of receiving an Emergency Off command (F603), this parameter determines the time that the DC Injection braking is applied to the motor.</p>	<p>Direct Access Number — F604</p> <p>Parameter Type — Numerical</p> <p>Factory Default — 0.10</p> <p>Changeable During Run — Yes</p> <p>Minimum — 0.00</p> <p>Maximum — 10.00</p> <p>Units — Seconds</p>
<p>Output Phase Loss Detection</p> <p>Program ⇒ Protection Parameters ⇒ Phase Loss</p> <p>This parameter Enables/Disables the monitoring of each phase of the 3-phase output signal (U, V, or W) of the ASD. If either line is missing, inactive, or not of the specified level, the ASD incurs a trip.</p> <p>Settings:</p> <ul style="list-style-type: none"> Disabled Enabled (box checked) 	<p>Direct Access Number — F605</p> <p>Parameter Type — Check Box</p> <p>Factory Default — Disabled</p> <p>Changeable During Run — No</p>
<p>OL Reduction Starting Frequency</p> <p>Program ⇒ Protection Parameters ⇒ Overload</p> <p>This parameter is used to reduce the start frequency during very low-speed motor operation. During very low-speed operation the cooling efficiency of the motor decreases. Lowering the start frequency aides in minimizing the generated heat.</p>	<p>Direct Access Number — F606</p> <p>Parameter Type — Numerical</p> <p>Factory Default — 6.00</p> <p>Changeable During Run — Yes</p> <p>Minimum — 0.00</p> <p>Maximum — 30.00</p> <p>Units — Hz</p>

<p>Motor 150% OL Time Limit</p> <p>Program ⇒ Protection Parameters ⇒ Overload</p> <p>This parameter establishes a time that the motor may operate at 150% of its rated current before tripping. This setting applies the time/150% reference to the individual settings of each motor (e.g., this setting references 150% of the F600 setting for the #1 motor).</p> <p>The unit will trip sooner than the time entered here if the overload is greater than 150%.</p>	<p>Direct Access Number — F607</p> <p>Parameter Type — Numerical</p> <p>Factory Default — 600</p> <p>Changeable During Run — Yes</p> <p>Minimum — 10</p> <p>Maximum — 2400</p> <p>Units — Seconds</p>
<p>Inrush Current Suppression</p> <p>Program ⇒ Protection Parameters ⇒ Soft Start</p> <p>The startup inrush current may be suppressed for up to 2.5 seconds. This parameter determines the length of the inrush current suppression.</p>	<p>Direct Access Number — F608</p> <p>Parameter Type — Numerical</p> <p>Factory Default — 0.30</p> <p>Changeable During Run — No</p> <p>Minimum — 0.30</p> <p>Maximum — 2.50</p> <p>Units — Seconds</p>
<p>Interlock with ST</p> <p>Program ⇒ Protection Parameters ⇒ Soft Start</p> <p>This parameter Enables/Disables the ST-to-CC connection dependency on the successful completion of a Soft Start. If enabled, the ST-to-CC connection will happen only after a successful Soft Start.</p>	<p>Direct Access Number — F609</p> <p>Parameter Type — Check Box</p> <p>Factory Default — Disabled</p> <p>Changeable During Run — No</p>
<p>Low Current Trip</p> <p>Program ⇒ Protection Parameters ⇒ Low Current Settings</p> <p>This parameter Enables/Disables the low-current trip feature.</p> <p>When enabled, the drive will trip on a low-current fault if the output current of the drive falls below the level defined at F611 and remains there for the time set at F612.</p> <p>Settings:</p> <ul style="list-style-type: none"> Disabled Enabled (box checked) 	<p>Direct Access Number — F610</p> <p>Parameter Type — Check Box</p> <p>Factory Default — Disabled</p> <p>Changeable During Run — No</p>
<p>Low Current Trip Threshold</p> <p>Program ⇒ Protection Parameters ⇒ Low Current Settings</p> <p>When the low-current monitor is enabled, this function sets the low-current trip threshold. The threshold value is entered as a percentage of the maximum rating of the drive.</p>	<p>Direct Access Number — F611</p> <p>Parameter Type — Numerical</p> <p>Factory Default — 0.00</p> <p>Changeable During Run — Yes</p> <p>Minimum — 0.00</p> <p>Maximum — 100.0</p> <p>Units — %</p>
<p>Low Current Trip Threshold Time</p> <p>Program ⇒ Protection Parameters ⇒ Low Current Settings</p> <p>When the low-current monitor is enabled, this function sets the time that the low-current condition must exist to cause a trip.</p>	<p>Direct Access Number — F612</p> <p>Parameter Type — Numerical</p> <p>Factory Default — 0</p> <p>Changeable During Run — Yes</p> <p>Minimum — 0</p> <p>Maximum — 255</p> <p>Units — Seconds</p>

<p>Short Circuit Test</p> <p>Program ⇒ Protection Parameters ⇒ Arm Short Check Settings</p> <p>This parameter determines when the system will perform an Output Short Circuit test.</p> <p>Settings:</p> <ul style="list-style-type: none"> Every Run Every Powerup Never 	<p>Direct Access Number — F613</p> <p>Parameter Type — Selection List</p> <p>Factory Default — Every Run</p> <p>Changeable During Run — No</p>
<p>Short Circuit Test Duration</p> <p>Program ⇒ Protection Parameters ⇒ Arm Short Check Settings</p> <p>This parameter sets the pulse width of the ASD output pulse that is applied to the motor during an Output Short Circuit test.</p>	<p>Direct Access Number — F614</p> <p>Parameter Type — Numerical</p> <p>Factory Default — (ASD-dependent)</p> <p>Changeable During Run — No</p> <p>Minimum — 1</p> <p>Maximum — 100</p> <p>Units — μS</p>
<p>Overtorque Trip</p> <p>Program ⇒ Protection Parameters ⇒ Overtorque Parameters</p> <p>This parameter Enables/Disables the Over Torque Tripping function.</p> <p>When enabled, the ASD trips if an output torque value greater than the setting of F616 or F617 exists for a time longer than the setting of F618.</p> <p>When disabled, the ASD does not trip due to overtorque conditions.</p> <p>Settings:</p> <ul style="list-style-type: none"> Disabled Enabled (box checked) 	<p>Direct Access Number — F615</p> <p>Parameter Type — Check Box</p> <p>Factory Default — Disabled</p> <p>Changeable During Run — No</p>
<p>Overtorque Trip/Alarm Level (Positive Torque)</p> <p>Program ⇒ Protection Parameters ⇒ Overtorque Parameters</p> <p>This parameter sets the torque threshold level that is used as a setpoint for overtorque tripping. This setting is a percentage of the maximum rated torque of the drive.</p>	<p>Direct Access Number — F616</p> <p>Parameter Type — Numerical</p> <p>Factory Default — 150.0</p> <p>Changeable During Run — No</p> <p>Minimum — 0.00</p> <p>Maximum — 250.0</p> <p>Units — %</p>
<p>Overtorque Trip/Alarm Level (Negative Torque)</p> <p>Program ⇒ Protection Parameters ⇒ Overtorque Parameters</p> <p>This parameter sets the torque threshold level that is used as a setpoint for overtorque tripping during regeneration. This setting is a percentage of the maximum rated torque of the drive.</p>	<p>Direct Access Number — F617</p> <p>Parameter Type — Numerical</p> <p>Factory Default — 150.0</p> <p>Changeable During Run — No</p> <p>Minimum — 0.00</p> <p>Maximum — 250.0</p> <p>Units — %</p>

<p>Overtorque Detection Time</p> <p>Program ⇒ Protection Parameters ⇒ Overtorque Parameters</p> <p>This parameter sets the amount of time that the overtorque condition may exceed the tripping threshold level set at F616 and F617 before a trip occurs.</p>	<p>Direct Access Number — F618</p> <p>Parameter Type — Numerical</p> <p>Factory Default — 0.50</p> <p>Changeable During Run — No</p> <p>Minimum — 0.00</p> <p>Maximum — 100.0</p> <p>Units — Seconds</p>
<p>Cooling Fan Control</p> <p>Program ⇒ Protection Parameters ⇒ Cooling Fan Settings</p> <p>This parameter sets the cooling fan run-time command.</p> <p>Settings:</p> <ul style="list-style-type: none"> Automatic Always On Internal/External Temp. Controlled Internal-Auto/External-Temp. Controlled Internal-Temp. Controlled/External-Auto 	<p>Direct Access Number — F620</p> <p>Parameter Type — Selection List</p> <p>Factory Default — Automatic</p> <p>Changeable During Run — Yes</p>
<p>Cumulative Run Timer Alarm Setting</p> <p>Program ⇒ Protection Parameters ⇒ Cumulative Run Timer</p> <p>This parameter sets a run-time value that, once exceeded, closes a contact. The output signal may be used to control external equipment or used to engage a brake.</p> <p><i>Note: The time displayed is 1/10th of the actual time (0.1 hr. = 1.0 hr.).</i></p>	<p>Direct Access Number — F621</p> <p>Parameter Type — Numerical</p> <p>Factory Default — 175.0</p> <p>Changeable During Run — Yes</p> <p>Minimum — 0.1</p> <p>Maximum — 999.9</p> <p>Units — Hours (X 100)</p>
<p>Abnormal Speed Detection Filter Time</p> <p>Program ⇒ Protection Parameters ⇒ Abnormal Speed Settings</p> <p>This parameter sets the time that an overspeed condition must exist to cause a trip.</p>	<p>Direct Access Number — F622</p> <p>Parameter Type — Numerical</p> <p>Factory Default — 10.0</p> <p>Changeable During Run — No</p> <p>Minimum — 0.01</p> <p>Maximum — 100.0</p> <p>Units — Seconds</p>
<p>Overspeed Detection Frequency Range</p> <p>Program ⇒ Protection Parameters ⇒ Abnormal Speed Settings</p> <p>This parameter sets the upper level of the Base Frequency range that, once exceeded, will cause an Overspeed Detected alert.</p>	<p>Direct Access Number — F623</p> <p>Parameter Type — Numerical</p> <p>Factory Default — 0.0</p> <p>Changeable During Run — Yes</p> <p>Minimum — 0.0</p> <p>Maximum — 30.0</p> <p>Units — Hz</p>

<p>Speed Drop Detection Frequency Range</p> <p>Program ⇒ Protection Parameters ⇒ Abnormal Speed Settings</p> <p>This parameter sets the lower level of the Base Frequency range that, once exceeded, will cause a Speed Drop Detected alert.</p>	<p>Direct Access Number — F624</p> <p>Parameter Type — Numerical</p> <p>Factory Default — 0.00</p> <p>Changeable During Run — Yes</p> <p>Minimum — 0.00</p> <p>Maximum — 30.00</p> <p>Units — Hz</p>
<p>Overvoltage Stall Level (fast)</p> <p>Program ⇒ Protection Parameters ⇒ Stall</p> <p>This parameter sets the upper DC bus voltage threshold that, once exceeded, will cause an Overvoltage Stall. An Overvoltage Stall increases the output frequency of the drive during deceleration for a specified time in an attempt to prevent an Overvoltage Trip.</p> <p>If the overvoltage condition persists for over 250 μs, an Overvoltage Trip will be incurred.</p> <p><i>Note:</i> This feature may increase deceleration times.</p>	<p>Direct Access Number — F625</p> <p>Parameter Type — Numerical</p> <p>Factory Default — (ASD-dependent)</p> <p>Changeable During Run — Yes</p> <p>Minimum — 50.00</p> <p>Maximum — 250.0</p> <p>Units — %</p>
<p>Overvoltage Stall Level</p> <p>Program ⇒ Protection Parameters ⇒ Stall</p> <p>This parameter sets the upper DC bus voltage threshold that, once exceeded, will cause an Overvoltage Stall. An Overvoltage Stall increases the output frequency of the drive during deceleration for a specified time in an attempt to prevent an Overvoltage Trip.</p> <p>If the overvoltage condition persists for over 4 ms, an Overvoltage Trip will be incurred.</p> <p><i>Note:</i> This feature may increase deceleration times.</p>	<p>Direct Access Number — F626</p> <p>Parameter Type — Numerical</p> <p>Factory Default — (ASD-dependent)</p> <p>Changeable During Run — Yes</p> <p>Minimum — 50.0</p> <p>Maximum — 250.0</p> <p>Units — %</p>
<p>Undervoltage Trip</p> <p>Program ⇒ Protection Parameters ⇒ Undervoltage/Ridethrough</p> <p>This parameter Enables/Disables the Undervoltage Trip function.</p> <p>With this parameter Enabled, the ASD will trip if the undervoltage condition persists for a time greater than the F628 setting.</p> <p>A user-selected contact may be actuated if so configured.</p> <p>If Disabled the ASD will stop and not trip; the FL contact is not active.</p> <p>Settings:</p> <ul style="list-style-type: none"> Disabled Enabled (box checked) 	<p>Direct Access Number — F627</p> <p>Parameter Type — Check Box</p> <p>Factory Default — Disabled</p> <p>Changeable During Run — No</p>
<p>Undervoltage Detection Time</p> <p>Program ⇒ Protection Parameters ⇒ Undervoltage/Ridethrough</p> <p>This parameter sets the time that the undervoltage condition must exist to cause an Undervoltage trip when this function is enabled at F627.</p>	<p>Direct Access Number — F628</p> <p>Parameter Type — Numerical</p> <p>Factory Default — 0.03</p> <p>Changeable During Run — No</p> <p>Minimum — 0.00</p> <p>Maximum — 10.00</p> <p>Units — Seconds</p>

<p>Undervoltage Stall level</p> <p>Program ⇒ Protection Parameters ⇒ Undervoltage/Ridethrough</p> <p>This parameter sets the low end of the DC bus voltage threshold that, once it drops below this setting, will activate the setting of F302 (Ridethrough Mode). Activation may be the result of a momentary power loss or an excessive load on the bus voltage. Once activated, the system will attempt to maintain the bus voltage level set here until the motor stops.</p> <p><i>Note:</i> This feature may decrease deceleration times.</p>	<p>Direct Access Number — F629</p> <p>Parameter Type — Numerical</p> <p>Factory Default — (ASD-dependent)</p> <p>Changeable During Run — Yes</p> <p>Minimum — 50.00</p> <p>Maximum — 100.0</p> <p>Units — %</p>
<p>Brake Trouble Internal Timer</p> <p>Program ⇒ Protection Parameters ⇒ Brake Fault Timer</p> <p>This parameter is used in conjunction with the discrete input terminal setting 64 [System Consistent Sequence (BA: braking answer)] (see item 64 of Table 5 on pg. 162 for further information on this feature).</p> <p>After activating the discrete input terminal System Consistent Sequence (B: braking release), the setting of this parameter defines a window of time in which 1) a Braking Answer response must be received or 2) the brake must release.</p> <p>Should this timer setting expire before the Braking Answer is returned or the brake releases, a Brake Fault is incurred. Otherwise, the brake releases and normal motor operations resume.</p>	<p>Direct Access Number — F630</p> <p>Parameter Type — Numerical</p> <p>Factory Default — 0.00</p> <p>Changeable During Run — Yes</p> <p>Minimum — 0.00</p> <p>Maximum — 10.00</p> <p>Units — Seconds</p>
<p>Position Difference Limit</p> <p>Program ⇒ Feedback Parameters ⇒ Feedback Settings ⇒ Position Difference Limit</p> <p>While operating in the Position Control mode, this parameter sets the maximum allowed difference between the commanded position and resulting position as indicated by encoder pulses.</p>	<p>Direct Access Number — F631</p> <p>Parameter Type — Numerical</p> <p>Factory Default — 16.0</p> <p>Changeable During Run — No</p> <p>Minimum — 0.1</p> <p>Maximum — 6553</p>
<p>Release After Run Timer</p> <p>Program ⇒ Protection Parameters ⇒ Brake Fault Timer</p> <p>This parameter sets the time that the brake will hold after the Run command criteria has been met.</p>	<p>Direct Access Number — F632</p> <p>Parameter Type — Numerical</p> <p>Factory Default — 0.00</p> <p>Changeable During Run — No</p> <p>Minimum — 0.00</p> <p>Maximum — 2.50</p> <p>Units — Seconds</p>
<p>Earth Fault Alarm Level</p> <p>Program ⇒ Protection ⇒ Earth Fault Alarm Level</p> <p>This parameter sets the threshold level (%) that must be exceeded to meet the Earth Fault Alarm activation criteria.</p>	<p>Direct Access Number — F640</p> <p>Parameter Type — Numerical</p> <p>Factory Default — 100</p> <p>Changeable During Run — Yes</p> <p>Minimum — 0</p> <p>Maximum — 100</p> <p>Units — %</p>

<p>Earth Fault Alarm Time</p> <p>Program ⇒ Protection ⇒ Earth Fault Alarm Time</p> <p>In the event that the Earth Fault Alarm activation criteria is met, a timer begins to count down to zero. Upon reaching zero, the Earth Fault Alarm is activated.</p> <p>This parameter sets the start-time of the count-down timer.</p>	<p>Direct Access Number — F641</p> <p>Parameter Type — Numerical</p> <p>Factory Default — 1.00</p> <p>Changeable During Run — Yes</p> <p>Minimum — 0.00</p> <p>Maximum — 2.50</p> <p>Units — Seconds</p>
<p>Earth Fault Trip Level</p> <p>Program ⇒ Protection ⇒ Earth Fault Trip Level</p> <p>This parameter sets the threshold level (%) that must be exceeded to meet the Earth Fault Trip activation criteria.</p>	<p>Direct Access Number — F642</p> <p>Parameter Type — Numerical</p> <p>Factory Default — 100</p> <p>Changeable During Run — Yes</p> <p>Minimum — 0.00</p> <p>Maximum — 100</p> <p>Units — %</p>
<p>Earth Fault Trip Time</p> <p>Program ⇒ Protection ⇒ Earth Fault Trip Time</p> <p>In the event that the Earth Fault Trip activation criteria is met, a timer begins to count down to zero. Upon reaching zero, the Earth Fault Trip is activated.</p> <p>This parameter sets the start-time of the count-down timer.</p>	<p>Direct Access Number — F643</p> <p>Parameter Type — Numerical</p> <p>Factory Default — 1.00</p> <p>Changeable During Run — Yes</p> <p>Minimum — 0.00</p> <p>Maximum — 2.50</p> <p>Units — Seconds</p>
<p>Acc/Dec Base Frequency Adjustment</p> <p>Program ⇒ Terminal Selection Parameters ⇒ Analog Input Functions</p> <p>This parameter Enables/Disables the feature that allows for the external adjustment of the Base Frequency. When enabled, either VI/II or RR may be used as an input source for the modification of the Base Frequency setting.</p> <p>Settings:</p> <ul style="list-style-type: none"> Disabled VI/II RR 	<p>Direct Access Number — F650</p> <p>Parameter Type — Selection List</p> <p>Factory Default — Disabled</p> <p>Changeable During Run — Yes</p>
<p>Upper Limit Frequency Adjustment</p> <p>Program ⇒ Terminal Selection Parameters ⇒ Analog Input Functions</p> <p>This parameter Enables/Disables the feature that allows for the external adjustment of the Upper Limit. When enabled, either VI/II or RR may be used as an input source for the modification of the Upper Limit setting.</p> <p>Settings:</p> <ul style="list-style-type: none"> Disabled VI/II RR 	<p>Direct Access Number — F651</p> <p>Parameter Type — Selection List</p> <p>Factory Default — Disabled</p> <p>Changeable During Run — Yes</p>

Acceleration Time AdjustmentProgram ⇒ Terminal Selection Parameters ⇒ **Analog Input Functions**

This parameter **Enables/Disables** the feature that allows for the external adjustment of the **Acceleration Time**. Selecting either **VI/II** or **RR** enables this feature. The selected input is used as a multiplier of the programmed **Acceleration Time** setting. The multiplication factor may be from 1 to 10.

Note: *An acceleration time shorter than the load will allow may cause nuisance tripping and mechanical stress to loads.*

Settings:

Disabled
VI/II
RR

Direct Access Number — F652Parameter Type — **Selection List**Factory Default — **Disabled**Changeable During Run — **Yes**

Deceleration Time AdjustmentProgram ⇒ Terminal Selection Parameters ⇒ **Analog Input Functions**

This parameter **Enables/Disables** the feature that allows for the external adjustment of the **Deceleration Time**. Selecting either **VI/II** or **RR** enables this feature. The selected input is used as a modifier of the programmed **Deceleration Time** setting.

Note: *A deceleration time shorter than the load will allow may cause nuisance tripping and mechanical stress to loads.*

Settings:

Disabled
VI/II
RR

Direct Access Number — F653Parameter Type — **Selection List**Factory Default — **Disabled**Changeable During Run — **Yes**

Torque Boost AdjustmentProgram ⇒ Terminal Selection Parameters ⇒ **Analog Input Functions**

This parameter **Enables/Disables** the feature that allows for the external adjustment of the **Torque Boost** setting. Selecting either **VI/II** or **RR** enables this feature. The selected input is used as a modifier of the programmed **Torque Boost** setting.

Settings:

Disabled
VI/II
RR

Direct Access Number — F654Parameter Type — **Selection List**Factory Default — **Disabled**Changeable During Run — **Yes**

Frequency Override Additive Input

Program ⇒ Feedback Parameters ⇒ **Override Control**

This parameter **Enables/Disables** the feature that allows for the external adjustment of the **Output Frequency**.

Selecting either of the input methods listed enables this feature. The selected input is used as a modifier of the programmed **Output Frequency**.

Settings:

- Disabled
- VI/II
- RR
- RX
- RX2 (option)
- LED Keypad (option)
- Binary/BCD Input
- Common Serial (TTL)
- RS232/RS485
- Communication Card
- Motorized Pot
- Pulse Input 1

Direct Access Number — F660

Parameter Type — **Selection List**

Factory Default — **Disabled**

Changeable During Run — **No**

Frequency Override Multiplying Input

Program ⇒ Feedback Parameters ⇒ **Override Control**

This parameter **Enables/Disables** the feature that allows for the external adjustment of the **Output Frequency**.

Selecting either of the input methods listed enables this feature. The selected input is used as a multiplier of the programmed **Output Frequency**.

If operating using the **LED Keypad Option** and **Setting** is selected, the value entered at **F729** is used as the multiplier.

Settings:

- Disabled
- VI/II
- RR
- RX
- RX2 (option)
- Setting (LED Keypad Option Only)

Direct Access Number — F661

Parameter Type — **Selection List**

Factory Default — **Disabled**

Changeable During Run — **No**

<p>AM Terminal Assignment</p> <p>Program ⇒ Meter Terminal Adjustment Parameters ⇒ AM</p> <p>This parameter assigns a function to the AM output terminal. The AM output terminal produces an output current that is proportional to the magnitude of the function assigned to this terminal. The available assignments for this output terminal are listed in Table 6 on pg. 166.</p> <p><i>Note:</i> To read voltage at this terminal a 100 – 500Ω resistor is required and it must be connected from AM (+) to AM (-). The voltage is read across the 100 – 500Ω resistor.</p> <p><i>Current may be read by connecting an ammeter from AM (+) to FM (-).</i></p> <p>The AM analog output has a maximum resolution of 1/1024. The AM Terminal Adjustment (F671) must be used to calibrate the output signal for a proper response. SW-1 may be switched to allow for the full-range output to be either 0 – 1 mA or 4 – 20 mA when providing an output current, or either 0 – 1 or 1 – 7.5 volts when providing an output voltage at this terminal.</p>	<p>Direct Access Number — F670</p> <p>Parameter Type — Selection List</p> <p>Factory Default — Output Current</p> <p>Changeable During Run — Yes</p>
<p>AM Terminal Adjustment</p> <p>Program ⇒ Meter Terminal Adjustment Parameters ⇒ AM</p> <p>This function is used to calibrate the AM analog output terminal.</p> <p>To calibrate the AM analog output, connect a meter (current or voltage) as described at F670. With the drive running at a known frequency, adjust this parameter (F671) until the running frequency produces the desired DC level output at the AM terminal.</p>	<p>Direct Access Number — F671</p> <p>Parameter Type — Numerical</p> <p>Factory Default — 512</p> <p>Changeable During Run — Yes</p> <p>Minimum — 1</p> <p>Maximum — 1280</p>
<p>Analog 1 Terminal Setting</p> <p>Program ⇒ Meter Terminal Adjustment Parameters ⇒ Analog 1</p> <p>This parameter sets the Analog 1 multifunction programmable terminal to 1 of 33 possible functions and is available on the ASD Multicom option board only. Possible assignments for this output terminal are listed in Table 6 on pg. 166.</p>	<p>Direct Access Number — F672</p> <p>Parameter Type — Selection List</p> <p>Factory Default — Output Voltage</p> <p>Changeable During Run — Yes</p>
<p>Analog 1 Terminal Adjustment</p> <p>Program ⇒ Meter Terminal Adjustment Parameters ⇒ Analog 1</p> <p>This parameter adjusts the coefficient of the Analog 1 circuit to obtain an output that corresponds with a known input.</p> <p>This function is used in the calibration of external signal measuring devices (DVM, counters, etc.).</p>	<p>Direct Access Number — F673</p> <p>Parameter Type — Numerical</p> <p>Factory Default — 512</p> <p>Changeable During Run — Yes</p> <p>Minimum — 1</p> <p>Maximum — 1280</p>
<p>Analog 2 Terminal Setting</p> <p>Program ⇒ Meter Terminal Adjustment Parameters ⇒ Analog 2</p> <p>This parameter sets the Analog 2 multifunction programmable terminal to 1 of 33 possible functions and is available on the ASD Multicom option board only. Possible assignments for this output terminal are listed in Table 6 on pg. 166.</p>	<p>Direct Access Number — F674</p> <p>Parameter Type — Selection List</p> <p>Factory Default — Post-compensation Frequency</p> <p>Changeable During Run — Yes</p>

<p>Analog 2 Terminal Adjustment</p> <p>Program ⇒ Meter Terminal Adjustment Parameters ⇒ Analog 2</p> <p>This parameter adjusts the coefficient of the circuit to obtain an output that corresponds with a known input.</p> <p>This function is used in the calibration of external signal measuring devices (DVM, counters, etc.).</p>	<p>Direct Access Number — F675</p> <p>Parameter Type — Numerical</p> <p>Factory Default — 512</p> <p>Changeable During Run — Yes</p> <p>Minimum — 1</p> <p>Maximum — 1280</p>
<p>FP Terminal Setting</p> <p>Program ⇒ Terminal Selection Parameters ⇒ FP</p> <p>This parameter commands the multifunction programmable FP terminal to monitor the value of 1 of 33 possible system functions. As the monitored function changes in magnitude or frequency, the pulse count of the FP output pulse train changes in direct proportion to changes in the monitored function. As the monitored value goes up so does the pulse count of the FP output.</p> <p><i>Note:</i> The duty cycle of the output pulse train remains at $65 \pm 5.0 \mu\text{S}$.</p> <p>Possible assignments for this output terminal are listed in Table 6 on pg. 166.</p>	<p>Direct Access Number — F676</p> <p>Parameter Type — Selection List</p> <p>Factory Default — Output Frequency</p> <p>Changeable During Run — Yes</p>
<p>FP Terminal Adjustment</p> <p>Program ⇒ Terminal Selection Parameters ⇒ FP</p> <p>This parameter sets the full-scale reading of the FP Terminal. The full-scale reading of the monitored variable selected in F676 may be set here.</p>	<p>Direct Access Number — F677</p> <p>Parameter Type — Numerical</p> <p>Factory Default — 3.840</p> <p>Changeable During Run — Yes</p> <p>Minimum — 1.000</p> <p>Maximum — 43.200</p> <p>Units — kHz</p>
<p>Display Units for Voltage and Current</p> <p>Program ⇒ Utility Parameters ⇒ Display Units</p> <p>This parameter sets the unit of measurement for current and voltage values displayed on the EOI.</p> <p>Settings:</p> <p> %</p> <p> V/A</p>	<p>Direct Access Number — F701</p> <p>Parameter Type — Selection List</p> <p>Factory Default — %</p> <p>Changeable During Run — Yes</p>
<p>Hz Per User-defined Unit</p> <p>Program ⇒ Utility Parameters ⇒ Display Units</p> <p>This parameter allows the user to input a quantity to be displayed on the EOI that is proportional to the output frequency of the drive.</p> <p>This feature is useful when the output of a process is moved along at a rate that is proportional to the output frequency of the drive.</p>	<p>Direct Access Number — F702</p> <p>Parameter Type — Numerical</p> <p>Factory Default — 0.00</p> <p>Changeable During Run — Yes</p> <p>Minimum — 0.00</p> <p>Maximum — 200.0</p> <p>Units — Hz/UDU</p>
<p>Frequency Display Resolution</p> <p>Program ⇒ Utility Parameters ⇒ Display Units</p> <p>The parameter sets the number of decimal places to be displayed during non-Accel/Decel functions.</p>	<p>Direct Access Number — F703</p> <p>Parameter Type — Numerical</p> <p>Factory Default — 0.1</p> <p>Changeable During Run — Yes</p> <p>Minimum — 1</p> <p>Maximum — 0.01</p>

<p>Accel/Decel Special Display Resolution</p> <p>Program ⇒ Special Control Parameters ⇒ Accel/Decel Special</p> <p>This parameter sets the number of decimal places to be displayed for Accel/Decel functions.</p>	<p>Direct Access Number — F704</p> <p>Parameter Type — Numerical</p> <p>Factory Default — 0.1</p> <p>Changeable During Run — Yes</p> <p>Minimum — 1</p> <p>Maximum — 0.01</p>
<p>Prohibit Initializing User Parameters During Typeform Initialization</p> <p>Program ⇒ Special Control Parameters ⇒ Special Parameters ⇒ Prohibit Initializing User Parameters During Typeform Initialization</p> <p>This parameter Enables/Disables the ability to initialize user parameters during a Type Form initialization.</p> <p>Settings:</p> <ul style="list-style-type: none"> Allowed Prohibited 	<p>Direct Access Number — F709</p> <p>Parameter Type — Selection List</p> <p>Factory Default — Allowed</p> <p>Changeable During Run — Yes</p>
<p>V/f Group</p> <p>No path available (Direct Access Only)</p> <p>While operating using the LED Keypad Option 1 of 4 V/f groups may be selected and run. Each V/f group is comprised of 4 user-defined variables: Base Frequency, Base Frequency Voltage, Manual Torque Boost, and Electronic Thermal Protection. Expanded descriptions of these parameters may be found in this section (Direct Access Parameter Information).</p> <p>Settings:</p> <ul style="list-style-type: none"> Group 1 Group 2 Group 3 Group 4 <p><i>Note: If using the LCD EOI, press ESC from the Frequency Command screen to access this parameter.</i></p>	<p>Direct Access Number — F720</p> <p>Parameter Type — Selection List</p> <p>Factory Default — 1</p> <p>Changeable During Run — Yes</p>
<p>Stop Pattern</p> <p>No path available (Direct Access Only)</p> <p>While operating using the LED Keypad Option the Stop Pattern parameter determines the method used to stop the motor when the stop command is issued via a Stop command from the LED Keypad.</p> <p>The Decel Stop setting enables the Dynamic Braking system that is setup at F304 or the DC Injection Braking system that is setup at F250, F251, and F252 (Not used).</p> <p>The Coast Stop setting allows the motor to stop at the rate allowed by the inertia of the load.</p> <p>Settings:</p> <ul style="list-style-type: none"> Decel Stop Coast Stop <p><i>Note: The Stop Pattern setting has no effect on the Emergency Off settings of F603. If using the LCD EOI, press ESC from the Frequency Command screen to access this parameter.</i></p>	<p>Direct Access Number — F721</p> <p>Parameter Type — Selection List</p> <p>Factory Default — Decel Stop</p> <p>Changeable During Run — Yes</p>

<p>Torque Limit Group</p> <p>No path available (Direct Access Only)</p> <p>While operating using the LED Keypad Option this parameter is used to select 1 of 4 preset positive torque limits to apply to the active motor. The settings of profiles 1 – 4 may be setup at F441, F444, F446, and F448, respectively.</p> <p>Settings:</p> <ul style="list-style-type: none"> 1 2 3 4 <p><i>Note:</i> If using the LCD EOI, press ESC from the Frequency Command screen to access this parameter.</p>	<p>Direct Access Number — F723</p> <p>Parameter Type — Selection List</p> <p>Factory Default — 1</p> <p>Changeable During Run — Yes</p>
<p>Feedback in Panel Mode</p> <p>No path available (Direct Access Only)</p> <p>While operating using the LED Keypad Option this parameter Enables/Disables PID feedback control.</p> <p>Settings:</p> <ul style="list-style-type: none"> Enabled Disabled <p><i>Note:</i> If using the LCD EOI, press ESC from the Frequency Command screen to access this parameter.</p>	<p>Direct Access Number — F724</p> <p>Parameter Type — Selection List</p> <p>Factory Default — Enabled</p> <p>Changeable During Run — Yes</p>
<p>LED Option Override Multiplication Gain</p> <p>Program ⇒ Feedback Parameters ⇒ Override Control</p> <p>If operating using the LED Keypad Option this parameter provides a value to be used in the event that Setting is selected for the Frequency Override Multiplying Input (F661).</p>	<p>Direct Access Number — F729</p> <p>Parameter Type — Numerical</p> <p>Factory Default — 0.00</p> <p>Changeable During Run — Yes</p> <p>Minimum — -100.00</p> <p>Maximum — 100.00</p>
<p>LOD Control and Stopping Method</p> <p>Program ⇒ Special Control Parameters ⇒ Low Output Disable Function ⇒ LOD</p> <p>Enables/Disables the Low Output Disable function and, if enabled, selects a stopping method.</p> <p>Settings:</p> <ul style="list-style-type: none"> Disabled Enabled — Decel Stop Enabled — Coast Stop 	<p>Direct Access Number — F731</p> <p>Parameter Type — Selection List</p> <p>Factory Default — Disabled</p> <p>Changeable During Run — Yes</p>

<p>LOD Start Level (Hz)</p> <p>Program ⇒ Special Control Parameters ⇒ Low Output Disable Function ⇒ LOD Start Level (Hz)</p> <p>The Low Output Disable Start Level sets the output frequency threshold that, if exceeded, will initiate the LOD function if properly configured.</p>	<p>Direct Access Number — F732</p> <p>Parameter Type — Numerical</p> <p>Factory Default — 0.0</p> <p>Changeable During Run — Yes</p> <p>Minimum — 0.0</p> <p>Maximum — Max. Freq.</p> <p>Units — Hz</p>
<p>LOD Start Time</p> <p>Program ⇒ Special Control Parameters ⇒ Low Output Disable Function ⇒ LOD Start Time</p> <p>The Low Output Disable Start Time sets the amount of time that the LOD Start Level criteria must be met and maintained for the LOD function to be initiated.</p>	<p>Direct Access Number — F733</p> <p>Parameter Type — Numerical</p> <p>Factory Default — 0.0</p> <p>Changeable During Run — Yes</p> <p>Minimum — 0.0</p> <p>Maximum — 3600.0</p> <p>Units — Seconds</p>
<p>LOD Setpoint Boost (Hz)</p> <p>Program ⇒ Special Control Parameters ⇒ Low Output Disable Function ⇒ LOD Setpoint Boost (Hz)</p> <p>The Low Output Disable feature adds the user-input frequency value to the commanded frequency.</p>	<p>Direct Access Number — F734</p> <p>Parameter Type — Numerical</p> <p>Factory Default — 0.0</p> <p>Changeable During Run — Yes</p> <p>Minimum — 0.0</p> <p>Maximum — Max. Freq.</p> <p>Units — Hz</p>
<p>LOD Boost Time</p> <p>Program ⇒ Special Control Parameters ⇒ Low Output Disable Function ⇒ LOD Boost Time</p> <p>The Low Output Disable Boost Time sets the on-time timer for the LOD Boost function.</p> <p>Once expired, the LOD Boost function ceases.</p>	<p>Direct Access Number — F735</p> <p>Parameter Type — Numerical</p> <p>Factory Default — 0.0</p> <p>Changeable During Run — Yes</p> <p>Minimum — 0.0</p> <p>Maximum — 3600.0</p> <p>Units — Seconds</p>
<p>LOD Feedback Level (Hz)</p> <p>Program ⇒ Special Control Parameters ⇒ Low Output Disable Function ⇒ LOD Feedback Level (Hz)</p> <p>The Low Output Disable Feedback Level sets a frequency level that, until the output of the ASD drops below this setting, the Restart Delay Timer does not start.</p>	<p>Direct Access Number — F736</p> <p>Parameter Type — Numerical</p> <p>Factory Default — 0.0</p> <p>Changeable During Run — Yes</p> <p>Minimum — 0.0</p> <p>Maximum — Max. Freq.</p> <p>Units — Hz</p>
<p>LOD Restart Delay Time</p> <p>Program ⇒ Special Control Parameters ⇒ Low Output Disable Function ⇒ LOD Restart Delay Time</p> <p>The Low Output Disable Restart Delay Time sets the time that, once expired and all standard ASD requirements are met, normal ASD operation resumes.</p>	<p>Direct Access Number — F737</p> <p>Parameter Type — Numerical</p> <p>Factory Default — 0.0</p> <p>Changeable During Run — Yes</p> <p>Minimum — 0.0</p> <p>Maximum — 3600.0</p> <p>Units — Seconds</p>

<p>Communication Baud Rate (logic)</p> <p>Program ⇒ Communication Setting Parameters ⇒ Communication Settings</p> <p>This parameter plays a role in the setup of the communications network by establishing the Baud Rate of the communications link.</p> <p>The communications network includes other ASDs and Host/Control computers that monitor the status of the ASD(s), transfers commands, and loads or modifies the parameter settings of the ASD.</p> <p>Changes made to this parameter require that the power be cycled (Off then On) for the changes to take effect.</p>	<p>Direct Access Number — F800</p> <p>Parameter Type — Numerical</p> <p>Factory Default — 9600</p> <p>Changeable During Run — Yes</p> <p>Minimum — 1200</p> <p>Maximum — 9600</p> <p>Units — BPS</p>
<p>Parity</p> <p>Program ⇒ Communication Setting Parameters ⇒ Communication Settings</p> <p>This parameter plays a role in the setup of the communications network by establishing the Parity setting of the communications link.</p> <p>The communications network includes other ASDs and Host/Control computers that monitor the status of the ASD(s), transfers commands, and loads or modifies the parameter settings of the ASD.</p> <p>Changes made to this parameter require that the power be cycled (Off then On) for the changes to take effect.</p> <p>Settings:</p> <ul style="list-style-type: none"> No Parity Even Parity Odd Parity 	<p>Direct Access Number — F801</p> <p>Parameter Type — Selection List</p> <p>Factory Default — Even Parity</p> <p>Changeable During Run — Yes</p>
<p>ASD Number</p> <p>Program ⇒ Communication Setting Parameters ⇒ Communication Settings</p> <p>This parameter plays a role in the setup of the communications network by assigning an identification (ID) number to each ASD in the communications network.</p> <p>The communications network includes other ASDs and Host/Control computers that monitor the status of the ASD(s), transfers commands, and loads or modifies the parameter settings of the ASD.</p> <p>Changes made to this parameter require that the power be cycled (Off then On) for the changes to take effect.</p>	<p>Direct Access Number — F802</p> <p>Parameter Type — Numerical</p> <p>Factory Default — 0</p> <p>Changeable During Run — Yes</p> <p>Minimum — 0</p> <p>Maximum — 255</p>
<p>RS232/RS485 Communications Time Out Time</p> <p>Program ⇒ Communication Setting Parameters ⇒ Communication Settings</p> <p>This parameter plays a role in the setup of the communications network by setting the time that no activity may exist over the communications link before the link is severed (Time Out).</p> <p>The communications network includes other ASDs and Host/Control computers that monitor the status of the ASD(s), transfers commands, and loads or modifies the parameter settings of the ASD.</p> <p>Changes made to this parameter require that the power be cycled (Off then On) for the changes to take effect.</p>	<p>Direct Access Number — F803</p> <p>Parameter Type — Numerical</p> <p>Factory Default — 0</p> <p>Changeable During Run — Yes</p> <p>Minimum — 0</p> <p>Maximum — 100</p> <p>Units — Seconds</p>

<p>RS232/RS485 Communications Time-Out Action</p> <p>Program ⇒ Communication Setting Parameters ⇒ Communication Settings</p> <p>This parameter plays a role in the setup of the communications network by determining the action to be taken in the event of a time-out (Time-Out Action).</p> <p>The communications network includes other ASDs and Host/Control computers that monitor the status of the ASD(s), transfers commands, and loads or modifies the parameter settings of the drive.</p> <p>Changes made to this parameter require that the power be cycled (Off then On) for the changes to take effect.</p> <p>Settings:</p> <ul style="list-style-type: none"> No Action Alarm Trip 	<p>Direct Access Number — F804</p> <p>Parameter Type — Selection List</p> <p>Factory Default — Trip</p> <p>Changeable During Run — Yes</p>
<p>Communication Interval</p> <p>Program ⇒ Communication Setting Parameters ⇒ Communication Settings</p> <p>This parameter sets the Common Serial response delay time.</p> <p>Changes made to this parameter require that the power be cycled (Off then On) for the changes to take effect.</p>	<p>Direct Access Number — F805</p> <p>Parameter Type — Numerical</p> <p>Factory Default — 0.00</p> <p>Changeable During Run — Yes</p> <p>Minimum — 0.00</p> <p>Maximum — 2.00</p> <p>Units — Seconds</p>
<p>TTL Master Output</p> <p>Program ⇒ Communication Setting Parameters ⇒ Communication Settings</p> <p>In a master/follower configuration, this setting determines the output parameter of the master ASD that will be used to control the applicable follower ASDs.</p> <p><i>Note: Select No Follower if F826 is configured as a Master Output controller. Otherwise, an EOI failure will result.</i></p> <p>Changes made to this parameter require that the power be cycled (Off then On) for the changes to take effect.</p> <p>Settings:</p> <ul style="list-style-type: none"> No Follower (normal operation) Frequency Reference Output Command Frequency Torque Command Output Torque Command 	<p>Direct Access Number — F806</p> <p>Parameter Type — Selection List</p> <p>Factory Default — No Follower (normal operation)</p> <p>Changeable During Run — Yes</p>

Frequency Point Selection

Program ⇒ Communication Setting Parameters ⇒ **Communication Reference Adjust**

This parameter enables the communications reference for scaling by selecting an input type.

See **F811** — **F814** for further information on this setting.

Note: Scaling the communications signal is not required for all applications.

Changes made to this parameter require that the power be cycled (Off then On) for the changes to take effect.

Settings:

- Disabled
- Common Serial (TTL)
- RS232/RS485
- Communication Card

Direct Access Number — **F810**

Parameter Type — **Selection List**

Factory Default — **Disabled**

Changeable During Run — **Yes**

Communications Speed Reference #1

Program ⇒ Communication Setting Parameters ⇒ **Communication Reference Adjust**

When enabled at **F810**, this parameter is used to allow the user to set the gain and bias of the speed control input to the drive when the speed control signal is received via the source selected at **F810**.

Communications Input Speed Control Setup

Perform the following setup to allow the system to receive control input via Communications:

- Set **Communications Speed Reference #1 (F811)** — the input signal that represents **BIN Speed Frequency #1**.
- Set **Communications Speed Frequency #1 (F812)**.
- Set **Communications Speed Reference #2 (F813)** — the input signal that represents **BIN Speed Frequency #2**.
- Set **Communications Speed Frequency #2 (F814)**.
- Provide a **Run** command (**F** and/or **R**).

Once set, as the input signal value changes, the output frequency of the drive will vary in accordance with the above settings.

This parameter sets the **Communications Speed Reference #1** input value that represents **Communications Speed Frequency #1**. This value is entered as 0 to 100% of the **Communications Speed Reference #1** input value range.

Changes made to this parameter require that the power be cycled (Off then On) for the changes to take effect.

Direct Access Number — **F811**

Parameter Type — **Numerical**

Factory Default — **0.00**

Changeable During Run — **Yes**

Minimum — 0.00

Maximum — 100.0

Units — %

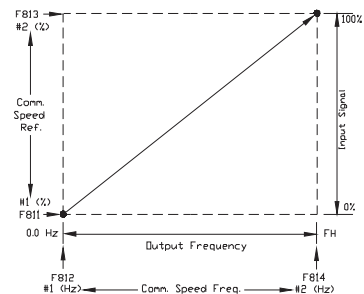

<p>Communications Speed Frequency #1</p> <p>Program ⇒ Communication Setting Parameters ⇒ Communication Reference Adjust</p> <p>This parameter is used to set the gain and bias of the Communications Reference speed control input.</p> <p>See F811 for further information on this setting.</p> <p>This parameter sets Communications Speed Frequency #1 and is the frequency that is associated with the setting of Communications Speed Reference #1.</p> <p>Changes made to this parameter require that the power be cycled (Off then On) for the changes to take effect.</p>	<p>Direct Access Number — F812</p> <p>Parameter Type — Numerical</p> <p>Factory Default — 0.00</p> <p>Changeable During Run — Yes</p> <p>Minimum — 0.00</p> <p>Maximum — Max. Freq. (F011)</p> <p>Units — Hz</p>
<p>Communications Speed Reference #2</p> <p>Program ⇒ Communication Setting Parameters ⇒ Communication Reference Adjust</p> <p>This parameter is used to set the gain and bias of the Communications Speed Reference #2 speed control input.</p> <p>See F811 for further information on this setting.</p> <p>This parameter sets the Communications Speed Reference #2 input value that represents Communications Speed Frequency #2. This value is entered as 0 to 100% of the Communications Speed Reference #2 input value range.</p> <p>Changes made to this parameter require that the power be cycled (Off then On) for the changes to take effect.</p>	<p>Direct Access Number — F813</p> <p>Parameter Type — Numerical</p> <p>Factory Default — 100.0</p> <p>Changeable During Run — Yes</p> <p>Minimum — 0.00</p> <p>Maximum — 100.0</p> <p>Units — %</p>
<p>Communications Speed Frequency #2</p> <p>Program ⇒ Communication Setting Parameters ⇒ Communication Reference Adjust</p> <p>This parameter is used to set the gain and bias of the Communications Speed Reference #2 speed control input.</p> <p>See F811 for further information on this setting.</p> <p>This parameter sets Communications Speed Frequency #2 and is the frequency that is associated with the setting of Communications Speed Reference #2.</p> <p>Changes made to this parameter require that the power be cycled (Off then On) for the changes to take effect.</p>	<p>Direct Access Number — F814</p> <p>Parameter Type — Numerical</p> <p>Factory Default — 80.0</p> <p>Changeable During Run — Yes</p> <p>Minimum — 0.0</p> <p>Maximum — Max. Freq. (F011)</p> <p>Units — Hz</p>
<p>RS232/RS485 Baud Rate</p> <p>Program ⇒ Communication Setting Parameters ⇒ Communication Settings</p> <p>This parameter sets the RS232/RS485 baud rate.</p> <p>Changes made to this parameter require that the power be cycled (Off then On) for the changes to take effect.</p> <p>Settings:</p> <ul style="list-style-type: none"> 1200 2400 4800 9600 19200 38400 	<p>Direct Access Number — F820</p> <p>Parameter Type — Selection List</p> <p>Factory Default — 9600</p> <p>Changeable During Run — Yes</p>

<p>RS232/RS485 Wire Count</p> <p>Program ⇒ Communication Setting Parameters ⇒ Communication Settings</p> <p>This parameter sets the communications protocol to the 2 or 4 wire method. Changes made to this parameter require that the power be cycled (Off then On) for the changes to take effect.</p> <p>Settings:</p> <ul style="list-style-type: none"> 2 wire 4 wire 	<p>Direct Access Number — F821</p> <p>Parameter Type — Selection List</p> <p>Factory Default — 4</p> <p>Changeable During Run — Yes</p>
<p>RS232/RS485 Response Delay Time</p> <p>Program ⇒ Communication Setting Parameters ⇒ Communication Settings</p> <p>This parameter sets the RS232/RS485 response delay time. Changes made to this parameter require that the power be cycled (Off then On) for the changes to take effect.</p>	<p>Direct Access Number — F825</p> <p>Parameter Type — Numerical</p> <p>Factory Default — 0.00</p> <p>Changeable During Run — Yes</p> <p>Minimum — 0.00</p> <p>Maximum — 2.00</p> <p>Units — Seconds</p>
<p>RS232/RS485 Master Output</p> <p>Program ⇒ Communication Setting Parameters ⇒ Communication Settings</p> <p>In a master/follower configuration, this setting determines the output parameter of the master ASD that will be used to control the applicable follower ASDs.</p> <p><i>Note: Select No Follower if F806 is configured as a Master Output controller. Otherwise, an EOI failure will result.</i></p> <p>Changes made to this parameter require that the power be cycled (Off then On) for the changes to take effect.</p> <p>Settings:</p> <ul style="list-style-type: none"> No Follower (normal operation) Frequency Reference Output Command Frequency Torque Command Output Torque Command 	<p>Direct Access Number — F826</p> <p>Parameter Type — Selection List</p> <p>Factory Default — No Follower (normal operation)</p> <p>Changeable During Run — Yes</p>
<p>Communication Error</p> <p>Program ⇒ Communication Setting Parameters ⇒ Communication Error</p> <p>In the event of a communication error during a transmission, the command that was transmitted may be cleared or held. Changes made to this parameter require that the power be cycled (Off then On) for the changes to take effect.</p> <p>Settings:</p> <ul style="list-style-type: none"> Command Request Cleared Command Request Held 	<p>Direct Access Number — F830</p> <p>Parameter Type — Selection List</p> <p>Factory Default — Command Request Cleared</p> <p>Changeable During Run — Yes</p>

Table 5. Discrete Input Terminal Assignment Selections and Descriptions.

1 — F — Enables Forward operation commands.																				
2 — R — Enables Reverse operation commands.																				
3 — ST — Enables the Forward and Reverse operation commands (maybe disabled at F103).																				
4 — RES — Resets the device and any incurred faults.																				
5 — S1 — Preset Speed Command 1 is used as the LSB of the 4-bit nibble that is used to select a Preset Speed .																				
6 — S2 — Preset Speed Command 2 is used as the second bit of the 4-bit nibble that is used to select a Preset Speed .																				
7 — S3 — Preset Speed Command 3 is used as the third bit of the 4-bit nibble that is used to select a Preset Speed .																				
8 — S4 — Preset Speed Command 4 is used as the MSB of the 4-bit nibble that is used to select a Preset Speed .																				
9 — Jog — Jog is the term used to describe turning on the motor for small increments of time and is used when precise positioning of motor-driven equipment is required. This terminal activates a Jog for the duration of activation. The Jog settings may be configured at F260 and F261 .																				
10 — Emergency Off — Terminates the output signal from the drive and may apply a brake. The braking method may be selected at F603 .																				
11 — DC Braking — The drive outputs a DC current that is injected into the windings of the motor to quickly brake the motor.																				
<p>Accel/Decel Switching 1/Accel/Decel Switching 2 — Activating combinations of discrete input terminals Accel/Decel Switching 1 and 2 allow for the selection of Accel/Decel profiles 1 – 4 as shown below.</p> <p>See F504 for more information on this terminal setting.</p> <table border="1" data-bbox="207 898 716 1220"> <thead> <tr> <th colspan="2">A/D SW Terminal</th> <th rowspan="2">A/D Selection</th> </tr> <tr> <th>#1</th> <th>#2</th> </tr> </thead> <tbody> <tr> <td>0</td> <td>0</td> <td>1</td> </tr> <tr> <td>0</td> <td>1</td> <td>2</td> </tr> <tr> <td>1</td> <td>0</td> <td>3</td> </tr> <tr> <td>1</td> <td>1</td> <td>4</td> </tr> <tr> <td colspan="2">1=Terminal Activated</td> <td></td> </tr> </tbody> </table> <p>The settings of the A/D selections 1 – 4 are performed at F009/F010, F500/F501, F510/F511, and F514/F515, respectively.</p> <p>Accel/Decel profiles are comprised of the Accel/Decel settings, Pattern, and Switching Frequency.</p>	A/D SW Terminal		A/D Selection	#1	#2	0	0	1	0	1	2	1	0	3	1	1	4	1=Terminal Activated		
A/D SW Terminal		A/D Selection																		
#1	#2																			
0	0	1																		
0	1	2																		
1	0	3																		
1	1	4																		
1=Terminal Activated																				
<p>V/f Switching 1/V/f Switching 2 — Activating combinations of discrete input terminals V/f Switching 1 and 2 allow for the selection of a V/f switching profile as listed below.</p> <table border="1" data-bbox="207 1318 834 1640"> <thead> <tr> <th colspan="2">V/f Switching Terminal</th> <th rowspan="2">V/f Selection</th> </tr> <tr> <th>#1</th> <th>#2</th> </tr> </thead> <tbody> <tr> <td>0</td> <td>0</td> <td>1</td> </tr> <tr> <td>0</td> <td>1</td> <td>2</td> </tr> <tr> <td>1</td> <td>0</td> <td>3</td> </tr> <tr> <td>1</td> <td>1</td> <td>4</td> </tr> <tr> <td colspan="2">1=Terminal Activated</td> <td></td> </tr> </tbody> </table> <p>The 1–4 settings of the V/f Switching selections are performed at parameters F170 – F181.</p>	V/f Switching Terminal		V/f Selection	#1	#2	0	0	1	0	1	2	1	0	3	1	1	4	1=Terminal Activated		
V/f Switching Terminal		V/f Selection																		
#1	#2																			
0	0	1																		
0	1	2																		
1	0	3																		
1	1	4																		
1=Terminal Activated																				
14 — Motor 1, 2 Switching — Motor control may be switched between the Motor #1 profile to the Motor #2 profile if using a multiple-motor profile configuration.																				
15 — Motor 3, 4 Switching — Motor control may be switched between the Motor #3 profile to the Motor #4 profile if using a multiple-motor profile configuration.																				
16 — Torque Limit 1, 2 Switching — Torque control may be switched between the Torque Limit #1 profile to the Torque Limit #2 profile if using a multiple-profile configuration.																				

Table 5. Discrete Input Terminal Assignment Selections and Descriptions.

17 — Torque Limit 3, 4 Switching — Torque control may be switched between the Torque Limit #3 profile to the Torque Limit #4 profile if using a multiple-profile configuration.
18 — PID Control Off — Connecting this terminal to CC turns off PID control.
19 — Pattern #1 — Connecting this terminal to CC initiates the Pattern #1 Pattern Run .
20 — Pattern #2 — Connecting this terminal to CC initiates the Pattern #2 Pattern Run .
21 — Pattern #3 — Connecting this terminal to CC initiates the Pattern #3 Pattern Run .
22 — Pattern #4 — Connecting this terminal to CC initiates the Pattern #4 Pattern Run .
23 — Pattern Continue — Continues with the last Pattern Run from its stopping point when connected to CC .
24 — Pattern Trigger — This function is used to sequentially initiate each Preset Speed of a Pattern Run with each connection to CC .
25 — Forced Jog Forward — This setting initiates a Forced Forward Jog when connected to CC . The Forced Forward Jog command provides a forward-run signal so long as this terminal is connected to CC (the status of the F and R terminals is ignored). Use F260 to set the Jog Frequency and use F261 to select the Jog Stop Method .
26 — Forced Jog Reverse — This setting initiates a Forced Reverse Jog when connected to CC . The Forced Reverse Jog command provides a reverse-run signal so long as this terminal is connected to CC (the status of the F and R terminals is ignored). Use F260 to set the Jog Frequency and use F261 to select the Jog Stop Method .
27 — Binary Bit 0 — Bit 0 – 7 may be set up as a speed/torque control register. Speed/torque settings may be applied to this group of terminals in binary form. The required number of input terminals should be set to the respective binary bit settings (0 – MSB). The Frequency Mode setting must be set to Use Binary/BCD input . The gain and bias of the binary input may be set from the following path: Program ⇒ Frequency Setting Parameters ⇒ Speed Reference Setpoints ⇒ BIN (see F228).
28 — Binary Bit 1 — See selection 27 above.
29 — Binary Bit 2 — See selection 27 above.
30 — Binary Bit 3 — See selection 27 above.
31 — Binary Bit 4 — See selection 27 above.
32 — Binary Bit 5 — See selection 27 above.
33 — Binary Bit 6 — See selection 27 above.
34 — Binary Bit 7 — See selection 27 above.
35 — Forced Stop — Activating this terminal terminates the Run command regardless of the Command Mode setting and initiates the programmed stopping method.
36 — Stop Key Emulation — Activating this terminal terminates the Run command being received from communications devices and initiates the programmed stopping method.
43 — Binary Data Write — This terminal serves two functions: 1) While operating in the Use Binary/BCD input mode, each momentary connection of this terminal to CC transfers the speed/torque Binary Bit (0 – MSB) settings to the motor. 2) The Motorized Pot frequency command will be saved during power down or reset by setting F108 to Store and setting an input terminal to 43:binary Data Write . If the drive is running and the Binary Data Write terminal is active when an event occurs (Fault, Power off), the Motorized Pot frequency command will be restored upon power-up or reset.
44 — Motorized Pot Up (MOP) — Momentarily connecting this terminal to CC causes an increase in motor speed for the duration of the connection until the Upper Limit is reached. The Frequency Mode setting must be set to Motorized Pot. Simulation . The MOP acceleration rate is determined by the F500 setting.
45 — Motorized Pot Down (MOP) — Momentarily connecting this terminal to CC causes a decrease in motor speed for the duration of the connection until the Lower Limit is reached. The Frequency Mode setting must be set to Motorized Pot. Simulation . The MOP deceleration rate is determined by the F501 setting.
46 — Motorized Pot Clear — Connecting this terminal to CC clears the last Motorized Pot frequency settings (see F108 for further information on this setting).

Table 5. Discrete Input Terminal Assignment Selections and Descriptions.

47 — Momentary Push Run — When connected to CC this terminal setting starts the motor.
48 — Momentary Push Stop — When connected to CC this terminal setting stops the motor.
49 — Forward/Reverse — This setting operates in conjunction with another terminal being set to the Run/Stop (50) function. When configured to Run (Run/Stop to CC) , the make or break of this connection to CC changes the direction of the motor.
50 — Run/Stop — This terminal enables the motor to run when connected to CC and disables the motor when the connection is broken.
51 — Line Power Bypass — This function operates in conjunction with the Line Power Switching frequency setting (F355). An enabled check box at Program ⇒ Terminal Selection Parameters ⇒ Line Power Switching (At) and this input terminal setting enables this function. Once configured (including this terminal connection to CC), the frequency setting of Line Power Switching (Hz) establishes the speed at which the drive terminates its output and routes commercial power to the motor.
52 — Frequency Priority — Connecting this terminal to CC allows for the frequency control to be switched from the frequency command source selected as Frequency Mode 1 to Frequency Mode 2 . This function is enabled by setting the Reference Priority Selection to Frequency Source Priority Switching and is located at Program ⇒ Fundamental Parameters ⇒ Standard Mode Selection ⇒ Reference Priority Selection ⇒ Frequency Source Priority Switching .
53 — VI/II Terminal Priority — Connecting this terminal to CC assigns command control to the VI/II Terminal and overrides all other Control Terminal Strip input so long as the Command Mode is set to Use Control Terminal Strip .
54 — Command Control Terminal Strip Priority — Connecting this terminal to CC overrides the FMOD setting and assigns speed control to the Control Terminal Strip .
55 — Parameter Editing Enabling (LED) — The LED Keypad system is unavailable at the time of this release.
56 — Control Switch (torque, position) — This function allows for a system change from speed to torque or position as a function of the V/f setting when connected to CC .
57 — Deviation Counter Clear — This function clears the Deviation Counter while operating in the Position Control mode.
58 — Position Control Forward Limit LS — Connecting this terminal to CC will immediately stop the drive and hold its position. If the connection remains the drive will time out and trip. This function is normally used for over-travel conditions.
59 — Position Control Reverse Limit LS — Connecting this terminal to CC will immediately stop the drive and hold its position. If the connection remains the drive will time out and trip. This function is normally used for over-travel conditions.
60 — Light-Load High-Speed Operation Enable — Activating this terminal sets the lower limit of an output frequency range in which the Light-load/High-speed function may be used (see F330). The Light-load/High-speed function accelerates the output frequency of the ASD to the speed setting established in F341 for the duration of the activation.
61 — Snap Stop Control Enable — TBD.
62 — Pre-excite Motor — Connecting this terminal to CC applies an excitation current to the motor (holds shaft stationary) for the duration of the connection.
63 — System Consistent Sequence (BC: braking command) — TBD.
64 — System Consistent Sequence (B: braking release) — Connecting this input terminal to CC initiates the brake release command. This setting requires that another discrete input terminal be set to 65 [System Consistent Sequence (BA: braking answer)] to complete the brake release command and to convey the status of the braking system to the user or to a dependent subsystem. Once the braking release function is initiated, the Trouble Internal Timer begins to count down (Trouble Internal Timer value is set at F630). Should the count-down timer expire before the brake releases or before the Braking Answer is returned, fault E-11 will occur. Otherwise, the brake releases the motor and normal motor operations resume. The Braking Release function is primarily used at startup; but, may be used when the brake is applied while the motor is running.

Table 5. Discrete Input Terminal Assignment Selections and Descriptions.

<p>65 — System Consistent Sequence (BA: braking answer) — This setting is required when the Braking Release (64) function is used. The function of this input terminal is to receive the returned the status of the braking system. The returned status is either Released or Not Released.</p> <p>If Released is returned within the time setting of F630, normal system function resumes.</p> <p>If Not Released is returned or if the F630 time setting times out before either signal is returned, then fault E-11 occurs.</p> <p>The returned signal may also be used to notify the user or control a dependent subsystem.</p>
<p>66 — System Consistent Sequence (BT: braking test) — TBD.</p>
<p>67 — Output Frequency Hold — TBD.</p>
<p>68 — MUV Disable — TBD.</p>

The magnitude of the AM/FM output signal at full-scale is selection-specific and may be adjusted (see **F671** and **F006**) to fit application-specific requirements. **Table 6** shows the default full-scale output setting of the AM/FM terminal for each selection. The column on the right side of **Table 6** shows the actual AM/FM output for an EOI display of 100% (default setting).

Table 6. Output terminal selections for the AM, FM, FP, and Analog 1 & 2 terminals.

Function	AM/FM Output Value at 100% EOI-Displayed Output	
Output Frequency (FM and FP default setting)	Maximum Frequency	
Frequency Reference		
Output Current (AM default setting)	150%	
DC Bus Voltage		
Output Voltage (Analog 1 default setting)		
Post-compensation Frequency (Analog 2 default setting)	Maximum Frequency	
Speed Feedback (realtime)		
Speed Feedback (1 sec filter)		
Torque	150%	
Torque Command		
Internal Torque Base		
Torque Current		
Excitation Current		
PID Feedback Value	Maximum Frequency	
Motor Overload Ratio	Motor Overload Trip Point Setting	
ASD Overload Ratio	ASD Overload Trip Point Setting	
PBR (DBR) Overload Ratio (Not used)	DBR Overload Trip Point Setting (Not used)	
PBR (DBR) Load Ratio	Maximum DBR Duty Cycle	
Input Power	1.73 * input voltage * ASD rated current	
Output Power		
Peak Output Current	150%	
Peak DC Bus Voltage		
PG Counter	32767 Encoder Pulses	
Position Pulse		
RR Input	100%	
VI/II Input		
RX Input		
RX2 Input		
FM Output (used for factory testing only)		
AM Output (used for factory testing only)		
Meter Adjust Value		
Analog Output		
Load Torque		150%

Table 7. Discrete Output Terminal Assignment Selections.

	Function		Function
0	Lower Limit (LL)	31	Ready for Operation (including ST and RUN)
1	Upper Limit (UL)	32	Ready for Operation
2	Low (speed setting of F100)	33	POFF Alarm (poor control power supply)
3	RCH (Acc/Dec completion)	34	System Consistent Sequence (BR: brake release)
4	RCH (speed specified at F101)	35	In Alarm Status
5	Fault FL (all)	36	Forward Speed Limit (torque control)
6	Fault FL (except EF or OCL)	37	Reverse Speed Limit (torque control)
7	Overcurrent Pre-alarm	38	ASD Healthy Output
8	ASD Overload Pre-alarm	39	Abnormal Communication Alarm 2 (internal cause)
9	Motor Pre-alarm	40	Error Code Output 1 (6-bit error output)
10	Overheat Pre-alarm	41	Error Code Output 2 (6-bit error output)
11	Overvoltage Pre-alarm	42	Error Code Output 3 (6-bit error output)
12	DC Voltage Low Alarm	43	Error Code Output 4 (6-bit error output)
13	Low-current Alarm	44	Error Code Output 5 (6-bit error output)
14	Overtorque Alarm	45	Error Code Output 6 (6-bit error output)
15	Braking Resistor Overload Pre-alarm	46	Designated Data Output 1 (7-bit transmission output)
16	In Emergency Off	47	Designated Data Output 2 (7-bit transmission output)
17	Retrying	48	Designated Data Output 3 (7-bit transmission output)
18	Pattern Operation Switching Out	49	Designated Data Output 4 (7-bit transmission output)
19	PID Deviation Limit	50	Designated Data Output 5 (7-bit transmission output)
20	Start/Stop	51	Designated Data Output 6 (7-bit transmission output)
21	Serious Fault (OCA, OCL, EF, Lost Phase, Short Circuit, or Abnormal Output)	52	Designated Data Output 7 (7-bit transmission output)
22	Light Fault (OL, OC1, 2, 3, OP)	53	Light Load Detection Signal
23	Bypass Output #1	54	Heavy Load Detection Signal
24	Bypass Output #2	55	Positive Torque Limit
25	Fan On/Off	56	Negative Torque Limit
26	Jogging	57	External Rush Suppression Relay Output
27	Control Terminal Strip Operation Command Mode	58	Over Travel
28	Total-operation-hours Alarm	59	Positioning Completion
29	Abnormal Communication Alarm (external cause)	60	Earth Fault Alarm
30	Forward/Reverse Operation	61	Low Output Disable Alarm

Alarms, Trips, and Troubleshooting

Alarms and Trips

This section lists the available user-notification codes of the EOI display and provides information that assists the user in the event that a **Fault** is incurred. The **User Notification** codes are displayed as an indication that a system function or system condition is active (i.e., ATN, DB, and DBON). The code is displayed on the EOI for the duration of the activation.

If a user setting or an ASD parameter has been exceeded, or if a data transfer function produces an unexpected result, a condition that is referred to as a **Fault** is incurred.

An **Alarm** is an indication that a **Fault** is imminent if existing operating conditions continue unchanged. An **Alarm** may be associated with an output terminal to notify the operator of the condition remotely, close a contact, or engage a brake. At the least, an **Alarm** will cause an alarm code to appear on the EOI display. [Table 8 on pg. 169](#) lists the 15 possible **Alarm** codes that may be displayed during operation of the HX7 ASD.

In the event that the condition that caused the **Alarm** does not return to its normal operating level within a specified time, the ASD **Faults** and a **Trip** is incurred (**Fault** and **Trip** are sometimes used interchangeably). A **Trip** is a safety feature, and is the result of a **Fault**, that disables the ASD system in the event that a subsystem of the ASD is malfunctioning, or one or more of the variables listed below exceeds its normal range (time and/or magnitude).

- Current,
- Voltage,
- Speed,
- Temperature,
- Torque, or
- Load.

See [Table 10 on pg. 172](#) for a listing of the potential **Trips** and the associated probable causes.

The operating conditions at the time of the trip may be used to help determine the cause of the trip. Listed below are operating conditions that may be used to assist the operator in correcting the problem or that the ASD operator should be prepared to discuss when contacting Toshiba's Customer Support for assistance.

- What trip information is displayed?
- Is this a new installation?
- Has the system ever worked properly and what are the recent modifications (if any)?
- What is the ASD/Motor size?
- What is the CPU version and revision level?
- What is the EOI version?
- Does the ASD trip when accelerating, running, decelerating, or when not running?
- Does the ASD reach the commanded frequency?
- Does the ASD trip without the motor attached?
- Does ASD trip with an unloaded motor?

Alarms

Table 8 lists the alarm codes that may be displayed during operation of the HX7 ASD. Each alarm code listed is accompanied by a description and a possible cause. In the event that the source of the malfunction cannot be determined, contact your Toshiba Sales Representative for further information on the condition and for an appropriate course of action.

The active **Alarm** is displayed on the **Frequency Command** screen. Multiple active alarms are displayed one at a time and are scrolled at one-second intervals.

Table 8. HX7 ASD Alarms.

EOI Display	Function	Description	Possible Causes
CM1	Comm1 Error	Internal communications error.	<ul style="list-style-type: none"> Improperly programmed ASD. Improper communications settings.
CM2	Comm2 Error	External communications error.	<ul style="list-style-type: none"> Improperly connected cables.
EMG	Emergency Off	Output signal from the ASD is terminated and a brake may be applied if so configured.	<ul style="list-style-type: none"> Stop Reset pressed twice at the EOI. EOFF command received remotely. ASD reset required.
MOFF	Main Undervoltage	Undervoltage condition at the 3-phase AC input to the ASD.	<ul style="list-style-type: none"> Low 3-phase input voltage.
OC	Over Current	ASD output current greater than the parameter F601 setting.	<ul style="list-style-type: none"> Defective IGBT (U, V, or W). ASD output to the motor is connected incorrectly. Disconnect the motor and retry. ASD output phase-to-phase short. The ASD is starting into a spinning motor. Motor/machine jammed. Mechanical brake engaged while the ASD is starting or while running. Accel/Decel time is too short. Voltage Boost setting is too high. Load fluctuations. ASD operating at an elevated temperature.
*OH	Overheat	ASD ambient temperature excessive.	<ul style="list-style-type: none"> ASD is operating at an elevated temperature. ASD is too close to heat-generating equipment. Cooling fan vent is obstructed (see Mounting the ASD on pg. 13). Cooling fan is inoperative. Internal thermistor is disconnected.
OJ	Timer	Run-time counter exceeded.	<ul style="list-style-type: none"> Type Reset required; select Clear run timer.
* Reset ignored if active.			

EOI Display	Function	Description	Possible Causes
*OLI	ASD Overload	Load requirement in excess of the capability of the ASD.	<ul style="list-style-type: none"> The carrier frequency is too high. An excessive load. Acceleration time is too short. DC damping rate is set too high. The motor is starting into a spinning load after a momentary power failure. The ASD is improperly matched to the application.
OLM	Motor Overload	Load requirement in excess of the capability of the motor.	<ul style="list-style-type: none"> V/f parameter improperly set. Motor is locked. Continuous operation at low speed. The load is in excess of what the motor can deliver.
*OLR	Resistor Overload	Excessive current at the Dynamic Braking Resistor .	<ul style="list-style-type: none"> Deceleration time is too short. DBR configuration improperly set.
*OP	Overvoltage	DC bus voltage exceeds specifications.	<ul style="list-style-type: none"> ASD attempting to start into a spinning motor after a momentary power loss. Incoming 3-phase power is above the specified range. Decel time is too short. Voltage spikes at the 3-phase input; install inductive filter. DBR required. DBR resistance value is too high. DBR function is turned off. Overvoltage Stall feature is turned off. System is regenerating. Load instability. Disable the Ridethrough function (F302).
OT	Overtorque	Torque requirement in excess of the setting of parameter F616 or F617 for a time longer than the setting of parameter F618.	<ul style="list-style-type: none"> ASD is not correctly matched to the application. Parameter F616 or F617 setting is too low. Obstructed load.
*POFF	Control Undervoltage	Undervoltage condition at the 5, 15, or the 24 VDC supply.	<ul style="list-style-type: none"> Defective Control board. Excessive load on power supply. Low input voltage.
PtSt	Reference Point	Two speed-reference frequency setpoint values are too close to each other.	<ul style="list-style-type: none"> Two speed reference frequency setpoints are too close to each other (increase the difference).
* Reset ignored if active.			

EOI Display	Function	Description	Possible Causes
UC	Undercurrent	Output current of the ASD is below the level defined at parameter F611 and remains there for the time set at parameter F612.	
* Reset ignored if active.			

User Notification Codes

The **User Notification** codes appear on the **Frequency Command** screen while the associated function is active.

User Notification codes notify the user of active functions that are usually only momentary under normal conditions and are active for the duration of activation only. User notification events are not error conditions and only convey active system functions to the user.

Table 9

EOI	Function	Description
Atn	Autotune Active	Atn indicates that the Autotune function is active. If the initial Autotune fails for any reason, an automatic retry is initiated if Other Motor is selected at parameter F413.
db or dbOn	DC Braking Active	This code conveys that the DC Injection function being carried out. The display shows db when braking and dbOn when the Shaft Stationary function is active.

Trips/Faults

A **Trip** is an ASD response to a **Fault** (though, **Fault** and **Trip** are sometimes used interchangeably). A **Trip** is a safety feature that disables the ASD system in the event that a subsystem of the ASD is malfunctioning.

Listed in [Table 10](#) are the possible **Faults** that may cause a **Trip** and the possible causes. When a **Trip** is incurred the system displays the **Fault** screen. The **Fault** screen identifies the active **Fault**.

Table 10

Fault Screen Display	Possible Causes
Inverter (ASD) OL	<ul style="list-style-type: none"> • Acceleration time is too short. • DC Injection current is too high. • V/f setting needs to be adjusted. • Motor running during restart. • ASD or the motor is improperly matched to the application.
Autotuning Err	<ul style="list-style-type: none"> • Autotune readings that are significantly inconsistent with the configuration information. • A non-3-phase motor is being used. • Incorrect settings at parameter F400, F413, or F414. • Using a motor that has a significantly smaller rating than the ASD. • ASD output cabling is too small, too long, or is being housed in a cable tray with other cables that are producing an interfering EMF. • Motor is running during the Autotune function.
Comm Error	<ul style="list-style-type: none"> • Communication malfunction. • Improper or loose connection. • Improper system settings.
Ctrl Undervolts	<ul style="list-style-type: none"> • This fault is caused by an undervoltage condition at the 5, 15, or the 24 VDC supply. • 3-phase input voltage low.
CPU Error	<ul style="list-style-type: none"> • CPU malfunction.
Main Undervolts	<ul style="list-style-type: none"> • 3-phase input voltage low. • Defective control board. • Excessive load on the power supply. • Undervoltage/Ridethrough settings require adjustment.
Fuse	<ul style="list-style-type: none"> • Internal DC bus fuse is open.
<p>Note: <i>The event that caused the Trip(s) must be corrected or must decrease to less than the threshold value required to cause the trip to allow for a Reset to be recognized. In the event of multiple active trips, the trip displayed will remain until all faults are corrected and all trips are cleared.</i></p>	

Fault Screen Display	Possible Causes
DBR Overcurrent	<ul style="list-style-type: none"> • ASD inability to discharge the bus voltage during regeneration. • No dynamic braking resistor (DBR) installed. • Deceleration time is too short. • Improper DBR setup information. • Defective IGBT7 (or IGBT7 ckt.). • 3-phase input voltage is above specification.
DBR Overload	<ul style="list-style-type: none"> • Deceleration time is too short. • DBR setting adjustment required. • Overvoltage Stall setting adjustment required.
GND Fault	<ul style="list-style-type: none"> • Ground fault at the motor. • Ground fault at the output of the ASD. • Current leakage to Earth Ground.
Ctrl EEPROM Err	<ul style="list-style-type: none"> • Internal EEPROM malfunction.
EEPROM Write Err	<ul style="list-style-type: none"> • EEPROM write malfunction.
E-Off	<ul style="list-style-type: none"> • Emergency Off command received via EOI or remotely.
Encoder Loss	<ul style="list-style-type: none"> • Encoder signal missing while running during closed-loop operation.
Flash Error	<ul style="list-style-type: none"> • Flash memory malfunction.
Gate Array Error	<ul style="list-style-type: none"> • Defective Gate Array or Gate Array malfunction.
In(put) Phase Loss	<ul style="list-style-type: none"> • 3-phase input to the ASD is low or missing.
Load Drooping	<ul style="list-style-type: none"> • Load requirement is in excess of the capabilities of the motor.
Load End OC	<ul style="list-style-type: none"> • Improper wiring at the ASD output to the motor.
Under Curr(ent) Trip	<ul style="list-style-type: none"> • Improper Low Current detection level setting.
Main EEPROM Err	<ul style="list-style-type: none"> • Internal EEPROM malfunction.
Motor Overload	<ul style="list-style-type: none"> • V/f setting needs to be adjusted. • Motor is locked. • Continuous operation at low speed. • Load requirement exceeds ability of the motor. • Startup frequency setting adjustment required.
Option PCB Error	<ul style="list-style-type: none"> • Optional device malfunction. • Improper system settings (at ASD or optional device). • Loose or improper connection.
Out(put) Phase Loss	<ul style="list-style-type: none"> • 3-phase output from the ASD is low or missing.
<p><i>Note: The event that caused the Trip(s) must be corrected or must decrease to less than the threshold value required to cause the trip to allow for a Reset to be recognized. In the event of multiple active trips, the trip displayed will remain until all faults are corrected and all trips are cleared.</i></p>	

Fault Screen Display	Possible Causes
Overcurrent Acc	<ul style="list-style-type: none"> • V/f setting needs to be adjusted. • Restart from a momentary power outage. • The ASD is starting into a rotating motor. • ASD/Motor not properly matched. • Phase-to-phase short (U, V, or W). • Accel time too short. • Voltage Boost setting is too high. • Motor/machine jammed. • Mechanical brake engaged while the ASD is running. • ASD current exceeds 340% of the rated FLA on ASDs that are 100 HP or less during acceleration. On ASDs that are greater than 100 HP, this fault occurs when the ASD current exceeds 320% of the rated FLA during acceleration.
Overcurrent Dec	<ul style="list-style-type: none"> • Phase-to-phase short (U, V, or W). • Deceleration time is too short. • Motor/machine jammed. • Mechanical brake engaged while the ASD is running. • ASD current exceeds 340% of the rated FLA on ASDs that are 100 HP or less during deceleration. On ASDs that are greater than 100 HP, it occurs when the ASD current exceeds 320% of the rated FLA during deceleration.
Overcurrent Run	<ul style="list-style-type: none"> • Load fluctuations. • ASD is operating at an elevated temperature. • ASD current exceeds 340% of the rated FLA on ASDs that are 100 HP or less during a fixed-speed run or if during a fixed-speed run the ASD overheats. On ASDs that are greater than 100 HP, it occurs when the ASD current exceeds 320% of the rated FLA on a fixed-speed run.
Overheat	<ul style="list-style-type: none"> • Cooling fan inoperative. • Ventilation openings are obstructed. • Internal thermistor is disconnected.
Speed Error	<ul style="list-style-type: none"> • Result of a motor speed that is greater than the commanded speed when using an encoder for speed control. • Improper encoder connection or setup information. • Defective encoder.
<p>Note: <i>The event that caused the Trip(s) must be corrected or must decrease to less than the threshold value required to cause the trip to allow for a Reset to be recognized. In the event of multiple active trips, the trip displayed will remain until all faults are corrected and all trips are cleared.</i></p>	

Fault Screen Display	Possible Causes
Overtorque	<ul style="list-style-type: none"> • A torque requirement by the load in excess of the setting of parameter F616 or F617 for a time longer than the setting of parameter F618. • The ASD is improperly matched to the application. • The load is obstructed.
Overvolt Accel	<ul style="list-style-type: none"> • Motor running during restart.
Overvolt Decel	<ul style="list-style-type: none"> • Deceleration time is too short. • DBR value is too high. • DBR required (DBR setup required). • Stall protection is disabled. • 3-phase input voltage is out of specification. • Input reactance required.
Overvolt Run	<ul style="list-style-type: none"> • Load fluctuations. • 3-Phase input voltage out of specification.
Positional Err	<ul style="list-style-type: none"> • Operating in the Position Control mode and the resulting position exceeds the limits of the Position Control setting.
RAM Err	<ul style="list-style-type: none"> • Internal RAM malfunction.
ROM Err	<ul style="list-style-type: none"> • Internal ROM malfunction.
Sink/Source Error	<ul style="list-style-type: none"> • Improperly positioned Sink/Source jumper on the control board or on an option device. • Sink/Source configuration of an option device is incorrect.
Type(form) Error	<ul style="list-style-type: none"> • Firmware information (typeform) loaded into the Gate Driver board is inconsistent with the device in which the firmware is being used. • The Gate Driver board has been replaced. • The Gate Driver board is defective.
U Phase OC	<ul style="list-style-type: none"> • Low impedance at the U lead of the ASD output.
V Phase OC	<ul style="list-style-type: none"> • Low impedance at the V lead of the ASD output.
W Phase OC	<ul style="list-style-type: none"> • Low impedance at the W lead of the ASD output.
<p>Note: <i>The event that caused the Trip(s) must be corrected or must decrease to less than the threshold value required to cause the trip to allow for a Reset to be recognized. In the event of multiple active trips, the trip displayed will remain until all faults are corrected and all trips are cleared.</i></p>	

Viewing Trip Information

In the event that the condition causing an **Alarm** does not return to the normal operating level within a specified time a **Trip** is incurred.

When a trip occurs, the resultant error information may be viewed either from the **Trip History** screen (Program ⇒ System Information and Setup ⇒ **Trip History**) or from the **Monitor** screen.

Trip History

The **Trip History** screen records the system parameters for up to 24 trips. The recorded trips are numbered from zero to 23. Once the **Trip History** record reaches trip number 23, the oldest recorded trip will be deleted with each new record stored (first-in first-out). The **Trip #** field may be selected and scrolled through to view the recorded trip information for a given trip number. The monitored parameters are listed in **Table 11** as **At-trip Recorded Parameters** (parameter readings at the time that the trip occurred).

Table 11. Trip History Record Parameters.

At-trip Recorded Parameters			
1) Trip Number	9) Bus Voltage	17) Torque Reference	25) ASD Load
2) Trip Type	10) Discrete Input Status	18) Torque Current	26) DBR Load
3) Time and Date	11) OUT1/OUT2/FL Status	19) Excitation Current	27) Input Power
4) Frequency at Trip	12) Timer	20) PID Value	28) Output Power
5) Output Current	13) Post Compensation Frequency	21) Motor Overload	29) Peak Current
6) Output Voltage	14) Feedback (inst.)	22) ASD Overload	30) Peak Voltage
7) Direction	15) Feedback (1 sec.)	23) DBR Overload	31) PG Speed
8) Frequency Reference	16) Torque	24) Motor Load	32) PG Position

Trip Record at Monitor Screen

The **Monitor** screen records and displays the trip name of up to four trips and catalogs each trip as **Past Trip #1**, **Past Trip #2**, **Past Trip #3**, and **Past Trip #4**. Once reset (**Clear Trip**), the trip records are erased. If no trips have occurred since the last reset, **No Error** is displayed for each trip record.

Note: An improper ASD setup may cause some trips — reset the ASD to the factory default settings before pursuing a systemic malfunction (Program ⇒ Utilities ⇒ Type Resets ⇒ **Restore Factory Defaults**).

The at-trip frequency of the last incurred trip may be viewed at the **Monitor** screen (see pg. 38). The **Monitor** screen at-trip record is erased when the ASD is reset. The current output frequency is displayed when there are no active trips.

Clearing a Trip

Once the cause of the trip has been corrected, performing a **Reset** re-enables the ASD for normal operation (clears the fault screen).

The fault screen may also be cleared using either of the following methods:

- Cycling power (trip info may be saved via parameter **F602** if desired),
- Pressing the **Stop|Reset** key twice,
- Remotely via the communications channel,
- Momentarily connecting terminal **RES** to **CC** of the **Control Terminal Strip**, or
- Via Program ⇒ Utilities ⇒ Type Resets ⇒ **Clear Past Trips**.

Index

Symbols

0 Hz Command Function, 93
0 Hz Dead Band Signal, 91

A

Abnormal Speed Detection Filter Time, 146
Abnormal Speed Settings, 37
Acc/Dec Base Frequency Adjustment, 149
Acc/Dec Group, 130
Acc/Dec Switching Frequency #1, 130
Accel #1 Time, 48
Accel #2 Time, 128
Accel #3 Time, 131
Accel #4 Time, 132
Accel/Decel #1 – #4 Settings, 42
Accel/Decel #1 Settings, 32
Accel/Decel Lower Limit Time, 131
Accel/Decel Pattern #1, 129
Accel/Decel Pattern #2, 130
Accel/Decel Pattern #3, 131
Accel/Decel Pattern #4, 132
Accel/Decel Settings, 42
Accel/Decel Special, 42
Accel/Decel Special Display Resolution, 154
Accel/Decel Switching Frequency #2, 132
Accel/Decel Switching Frequency #3, 133
Acceleration, 48
Acceleration Time Adjustment, 150
Adjust Accel/Decel Automatically, 22
Alarm Popups, 32
Alarms, 169
AM, 8, 10, 31, 41
AM Terminal Adjustment, 152
AM Terminal Assignment, 152
AM, FM, FP, and Analog 1&2 settings, 166
Analog, 152
Analog 1 Terminal Adjustment, 152
Analog 1 Terminal Setting, 152
Analog 2 Terminal Adjustment, 153
Analog 2 Terminal Setting, 152
Analog Filter, 35
Analog Input Filter, 77
Analog Input Functions, 34
Analog1, 41
Analog2, 41
Arm Short Check, 37
ASD Load, 31
ASD Number, 157

ASD Overload, 30
ASD-NANOCOM, 12
ASD-side Switching Wait Time, 107
At-Frequency Powerline Switching, 107
At-trip Recorded Parameters, 176
Automatic Accel/Decel #1, 45
Automatic Torque Boost, 45
Autotuning Err, 172

B

Base Frequency Volts, 37
Bias and Gain, 74, 78, 81, 84
BIN Input Control Setup, 87
BIN Speed Control Setup, 87
BIN Speed Frequency #1, 88
BIN Speed Frequency #2, 88
BIN Speed Reference #1, 87
BIN Speed Reference #2, 88
BIN Torque Control Setup, 87
BIN Torque Reference Setpoint #1, 88
BIN Torque Reference Setpoint #2, 89
Brake Fault Internal Timer, 148
Brake Fault Timer, 37
Break/Make Start, 98
Bus Voltage, 30

C

Carrier Frequency, 42, 98
CC, 8
Changed from Default, 32
Changed From Default screen, 20
Charge LED, 6
Clearing a Trip, 176
CM1, 169
CM2, 169
CN7 Pinout, 13
CNU1/1A and CNU2/2A Pinout, 14
CNU3 Pinout, 13
Comm Error, 172
Command Control Selections, 27
Command Mode Selection, 46
Command Source, 23
Commercial Power Switching Frequency
 Hold Time, 108
Commercial Power Wait Time, 108
Common Serial (TTL), 12
Communication Baud Rate (logic), 157

- Communication Error, 40, 161
- Communication Internal, 158
- Communication Reference Adjust, 40
- Communication Setting Parameters, 39
- Communication Settings, 39
- Communications Speed Frequency #1, 160
- Communications Speed Frequency #2, 160
- Communications Speed Reference #1, 159
- Communications Speed Reference #2, 160
- Compensation Coefficient for Iron Loss, 127
- concerns about this publication, 1
- Constant Vector Control, 126
- Continued Stall Until Trip During Power Operation, 123
- Contrast (adjustment), 32
- Control Board, 12
- Control Terminal Strip, 8
- CPU Error, 172
- Crane/Hoist Load, 42
- Ctrl EEPROM Err, 173
- Ctrl Undervolts, 172
- Cumulative Run Timer, 37
- Cumulative Run Timer Alarm Setting, 146
- Current Control Integral Gain, 111
- Current Control Proportional Gain, 111
- Current Differential Gain, 123
- Current Vector Control, 126
- Custom V/f Five-Point Setting #1 Frequency, 71
- Custom V/f Five-Point Setting #1 Voltage, 71
- Custom V/f Five-Point Setting #2 Frequency, 71
- Custom V/f Five-Point Setting #2 Voltage, 72
- Custom V/f Five-Point Setting #3 Frequency, 72
- Custom V/f Five-Point Setting #3 Voltage, 72
- Custom V/f Five-Point Setting #4 Frequency, 72
- Custom V/f Five-Point Setting #4 Voltage, 72
- Custom V/f Five-Point Setting #5 Frequency, 72
- Custom V/f Five-Point Setting #5 Voltage, 73

D

- Date and Time Setting, 32
- DBR Load, 31
- DBR Overcurrent, 173
- DBR Overload, 30, 173
- DC Braking, 36
- DC Injection Braking Current, 92
- DC Injection Braking Start Frequency, 92
- DC Injection Braking Time, 92
- Dead Time Compensation, 43
- Dead Time Compensation (Enable), 127
- Dead-time Compensation Bias, 127
- Decel #1 Time, 48
- Decel #2 Time, 128
- Decel #3 Time, 131

- Decel #4 Time, 132
- Deceleration Time Adjustment, 150
- Default Setting Changes, 19
- Default Term. Setting, 8
- Derate Threshold frequency, 98
- Direct Access, 32
- Direct Access Parameter Information, 45
- Direct Access Parameters/Numbers, 45
- Direction, 31
- Direction (of motor rotation), 48
- Discrete Input, 8
- Discrete Output, 8
- Display Units, 33
- Display Units for Voltage and Current, 153
- Disposal, 3
- Down Key, 17
- Driving Torque Limit #1, 121
- Driving Torque Limit #2, 121
- Driving Torque Limit #3, 122
- Driving Torque Limit #4, 122
- Drooping, 103
- Drooping Control, 39
- Drooping Gain, 103
- Drooping Insensitive Torque Range, 103
- Drooping Output Filter, 103
- Drooping Reference, 104
- Dynamic Braking, 36, 100
- Dynamic Braking Enable, 100

E

- Earth Fault Alarm Level, 148
- Earth Fault Alarm Time, 149
- Earth Fault Trip Level, 149
- Earth Fault Trip Time, 149
- EEPROM Write Err, 173
- Electronic Gear Setting, 110
- Electronic Operator Interface, 17
- Electronic Thermal Protection #1, 142
- Electronic Thermal Protection #2, 68
- Electronic Thermal Protection #3, 69
- Electronic Thermal Protection #4, 70
- Emergency Off DC Injection Application Time, 143
- Emergency Off Mode Settings, 143
- Emergency Off Setting, 36
- EMG, 169
- Encoder Action, 32
- Encoder Loss, 173
- End Frequency, 91
- Enter Key, 17
- E-Off, 173
- EOI Features, 17
- EOI Operation, 18

- EOI Setup Options, 32
- Equipment Inspection, 3
- Escape Key, 17
- Excitation Current, 30
- Excitation Starting Rate, 126
- Exciting Strengthening Coefficient, 125
- Extended Terminal Function, 56

F

- F, 8, 9
- F Input Terminal Assignment, 57
- F Input Terminal Delay, 63
- Fan Control, 37, 146
- Fault, 168
- Faults, 168
- Feedback 1-Second, 30
- Feedback in Panel Mode, 155
- Feedback Instantaneous, 30
- Feedback Parameters, 38
- Feedback Settings, 38
- Feedback Settings Differential (D) Gain, 109
- Feedback Source, 108
- Feedback Source Delay Filter, 108
- FL Off Delay, 67
- FL On Delay, 65
- FL Output Terminal Assignment, 62
- FLA, 8, 10
- FLA, B, and C switching relationship, 10
- Flash Error, 173
- FLB, 8, 10
- FLC, 8, 10
- FM, 8, 31, 41
- FM Terminal Adjustment, 47
- FM Terminal Assignment, 47
- Forward Speed Limit Input, 118
- Forward Speed Limit Level, 119
- FP, 8, 10
- FP Terminal Adjustment, 153
- FP Terminal Setting, 153
- FP Terminal Settings, 34
- Frequency Control, 42
- Frequency Control Selections, 28
- Frequency Display Resolution, 153
- Frequency for Automatic High-Speed Operation at Light-Load, 107
- Frequency Limit at Position, 111
- Frequency Mode #1, 46
- Frequency Mode #2, 32, 76
- Frequency Override Additive Input, 151
- Frequency Override Multiplying Input, 151

- Frequency Point Selection, 159
- Frequency Reference, 30
- Frequency Reference Source, 23
- Frequency Setting, 29, 32
- Frequency Setting Parameters, 35
- Fundamental, 32
- Fuse, 172
- Fwd/Rev Disable, 36

G

- Gate Array Error, 173
- General Safety Information, 1
- GND Fault, 173
- Group #1 Speed #1, 134
- Group #1 Speed #2, 134
- Group #1 Speed #3, 134
- Group #1 Speed #4, 134
- Group #1 Speed #5, 134
- Group #1 Speed #6, 135
- Group #1 Speed #7, 135
- Group #1 Speed #8, 135
- Group #1 Speed Repeat Factor, 134
- Group #2 Speed #1, 135
- Group #2 Speed #2, 135
- Group #2 Speed #3, 135
- Group #2 Speed #4, 135
- Group #2 Speed #5, 135
- Group #2 Speed #6, 135
- Group #2 Speed #7, 136
- Group #2 Speed #8, 136
- Group #2 Speed Repeat Factor, 135
- Group #3 Speed #1, 136
- Group #3 Speed #2, 136
- Group #3 Speed #3, 136
- Group #3 Speed #4, 136
- Group #3 Speed #5, 136
- Group #3 Speed #6, 136
- Group #3 Speed #7, 136
- Group #3 Speed #8, 137
- Group #3 Speed Repeat Factor, 136
- Group #4 Speed #1, 137
- Group #4 Speed #2, 137
- Group #4 Speed #3, 137
- Group #4 Speed #4, 137
- Group #4 Speed #5, 137
- Group #4 Speed #6, 137
- Group #4 Speed #7, 137
- Group #4 Speed #8, 137
- Group #4 Speed Repeat Factor, 137

H

- Handling and Storage, 3
- Heavy-Load Torque During Forward Acceleration, 106
- Heavy-Load Torque During Forward Deceleration, 106
- Heavy-Load Torque During Reverse Acceleration, 106
- Heavy-Load Torque During Reverse Deceleration, 106
- Hz Per User-defined Unit, 153

I

- I/O and Control, 7
- I/O Circuit Configurations, 14
- ICCDESIGNS, 12
- II, 10
- Important Notice, 4
- In(put) Phase Loss, 173
- Input Power, 31
- Input Special Functions, 34
- Input Terminal 12 Assignment, 60
- Input Terminal 13 Assignment, 60
- Input Terminal 14 Assignment, 61
- Input Terminal 15 Assignment, 61
- Input Terminal 16 Assignment, 61
- Input Terminal Assignment, 34
- Input Terminal Delays, 35
- Input Terminal Priority, 56
- Input Terminals, 30
- Inrush Current Suppression, 144
- Integral (I) Gain, 109
- Interlock with ST, 144
- Introduction, 4
- Inverter (ASD) OL, 172

J

- Jog Run Frequency, 94
- Jog Settings, 35
- Jog Setup Using the Control Terminal Strip, 94
- Jog Setup Using the EOI, 94
- Jog Stop Control, 95
- Jump Frequencies, 42
- Jump Frequency #1, 95
- Jump Frequency #1 Bandwidth, 95
- Jump Frequency #2, 95
- Jump Frequency #2 Bandwidth, 95
- Jump Frequency #3, 96
- Jump Frequency #3 Bandwidth, 96
- Jump Frequency Processing, 96

L

- LCD Display, 17
- LCD Port Connection, 40
- LED Option Override Multiplication Gain, 155
- Light-Load High-Speed Operation
 - Heavy-Load Detection Time, 105
- Light-Load High-Speed Operation Load
 - Detection Time, 105
- Light-Load High-Speed Operation Load Wait Time, 105
- Light-load High-speed Operation Selection, 104
- Light-Load High-Speed Operation Switching
 - Lower-Limit Frequency, 105
- Line Power Switching, 34, 35
- Load Drooping, 173
- Load End OC, 173
- Load Inertia (Acc/Dec Torque), 104
- Load Sharing Gain Input, 118
- Load Torque Filter (Acc/Dec Torque), 104
- Local Remote Key, 32
- Local|Remote Key, 18
- Lockout, 33
- LOD Boost Time, 156
- LOD Control and Stopping Method, 155
- LOD Feedback Level (Hz), 156
- LOD Restart Delay Time, 156
- LOD Setpoint Boost (Hz), 156
- LOD Start Level (Hz), 156
- LOD Start Time, 156
- Low Current Settings, 37
- Low Current Trip, 144
- Low Current Trip Threshold, 144
- Low Current Trip Threshold Time, 144
- Low Output Disable, 155
- Low Speed Signal Output Frequency, 53
- Lower Deviation Limits, 109
- Lower Limit Frequency, 21, 49

M

- Main EEPROM Err, 173
- Main Undervolts, 172
- Manual Torque Limit Settings, 38
- maximum Carrier Frequency, 98
- Maximum Frequency, 49
- Menu Options, 29
- Meter Terminal Adjustment Parameters, 41
- Mode #1/#2 Switching Frequency, 76
- MOFF, 169
- MON/PRG, 18
- Monitor Setup, 42
- MOP acceleration rate, 163
- MOP deceleration rate, 163

- Motor #1 Base Frequency, 49
- Motor #1 Max Output Voltage, 100
- Motor #1 Torque Boost, 50
- Motor #2 Base Frequency, 68
- Motor #2 Max Output Voltage, 68
- Motor #2 Torque Boost, 68
- Motor #3 Base Frequency, 69
- Motor #3 Max Output Voltage, 69
- Motor #3 Torque Boost, 69
- Motor #4 Base Frequency, 70
- Motor #4 Max Output Voltage, 70
- Motor #4 Torque Boost, 70
- Motor 150% OL Time Limit, 144
- Motor Capacity, 116
- Motor Constant 1 (primary resistance), 115
- Motor Constant 2 (secondary resistance), 115
- Motor Constant 3 (exciting inductance), 115
- Motor Constant 3 Enable, 116
- Motor Constant 4 (load inertia), 116
- Motor Constant 5 (leakage inductance), 116
- Motor Counter Data, 112
- Motor Current Rating, 22
- Motor Load, 31
- Motor Overload, 30, 173
- Motor Overload Trip, 37
- Motor Parameters, 41
- Motor Rating, 21
- Motor Set #1, 32, 41
- Motor Set #2, 41
- Motor Set #3, 41
- Motor Set #4, 41
- Motor Settings, 41
- Motor Shaft Fixing Control, 92
- Motor Shaft Stationary Control, 93
- Motor Type, 116
- Motorized Pot Frequency at Power Down, 57
- Motorized Pot Settings, 36

N

- Number of PG Input Pulses, 109
- Number of Poles of Motor, 116
- Number of Retries, 99

O

- O2A/B, 10
- OC, 169
- OH, 169
- OJ, 169
- OL Reduction Starting Frequency, 143
- OLI, 170

- OLM, 170
- OLR, 170
- ON Input Terminal Assignment, 57
- On-Trip Powerline Switching, 107
- OP, 170
- Operation (Local), 19
- Operational and Maintenance Precautions, 6
- Option PCB Error, 173
- OT, 170
- Out(put) Phase Loss, 173
- OUT1, 8, 10
- OUT1 Off Delay, 66
- OUT1 On Delay, 65
- OUT1 Output Terminal Assignment, 62
- OUT2, 8, 10
- OUT2 Off Delay, 66
- OUT2 On Delay, 65
- OUT2 Output Terminal Assignment, 62
- OUT4 Off Delay, 67
- OUT4 On Delay, 65
- OUT5 Off Delay, 67
- OUT5 On Delay, 66
- OUT6 Off Delay, 67
- OUT6 On Delay, 66
- OUT7 Off Delay, 67
- OUT7 On Delay, 66
- Output #4 Terminal Assignment, 62
- Output #5 Terminal Assignment, 63
- Output #6 Terminal Assignment, 63
- Output #7 Terminal Assignment, 63
- Output Current, 30
- output disconnect, 5
- Output Phase Loss Detection, 143
- Output Power, 31
- Output Terminal Assignments, 167
- Output Terminal Delays, 35
- Output Terminal Functions, 34
- Output terminal selections, 166
- Output Terminals, 30
- Output Voltage, 30
- Over Exciting Cooperation, 126
- Overcurrent Acc, 174
- Overcurrent Dec, 174
- Overcurrent Run, 174
- Overcurrent Stall Level, 142
- Overheat, 174
- Overload, 37
- Override Control, 39
- Overspeed Detection Frequency Range, 146
- Overtorque, 175
- Overtorque Detection Time, 146
- Overtorque Settings, 37
- Overtorque Trip, 145
- Overtorque Trip/Alarm Level (Negative Torque), 145

- Overtorque Trip/Alarm Level (Positive Torque), 145
- Overvolt Accel, 175
- Overvolt Decel, 175
- Overvolt Run, 175
- Over-voltage Stall, 100
- Overvoltage Stall Level, 147
- Overvoltage Stall Level (fast), 147

P

- P24, 8, 10
- PA, 100
- Panel Menu, 29
- Parity, 157
- Pattern #1 Characteristics (Pattern Run), 138
- Pattern #10 Characteristics (Pattern Run), 139
- Pattern #11 Characteristics (Pattern Run), 139
- Pattern #12 Characteristics (Pattern Run), 139
- Pattern #13 Characteristics (Pattern Run), 139
- Pattern #14 Characteristics (Pattern Run), 139
- Pattern #15 Characteristics (Pattern Run), 139
- Pattern #2 Characteristics (Pattern Run), 138
- Pattern #3 Characteristics (Pattern Run), 138
- Pattern #4 Characteristics (Pattern Run), 138
- Pattern #5 Characteristics (Pattern Run), 138
- Pattern #6 Characteristics (Pattern Run), 138
- Pattern #7 Characteristics (Pattern Run), 138
- Pattern #8 Characteristics (Pattern Run), 138
- Pattern #9 Characteristics (Pattern Run), 138
- Pattern Run, 39, 133
- Pattern Run #1 Run-Time Setting, 139
- Pattern Run #10 Run-Time Setting, 141
- Pattern Run #11 Run-Time Setting, 141
- Pattern Run #12 Run-Time Setting, 141
- Pattern Run #13 Run-Time Setting, 141
- Pattern Run #14 Run-Time Setting, 141
- Pattern Run #15 Run-Time Setting, 142
- Pattern Run #2 Continuation Mode Run-Time Setting, 139
- Pattern Run #3 Run-Time Setting, 140
- Pattern Run #4 Run-Time Setting, 140
- Pattern Run #5 Run-Time Setting, 140
- Pattern Run #6 Run-Time Setting, 140
- Pattern Run #7 Run-Time Setting, 140
- Pattern Run #8 Run-Time Setting, 140
- Pattern Run #9 Run-Time Setting, 141
- Pattern Run Control Parameters, 39
- Pattern Run Description, 133
- Pattern Run Setup, 133
- PB, 100
- Peak Current, 31
- Peak Voltage, 31
- PG Disconnect Detection, 110
- PG Input Phases, 110
- PG Input Speed Control Setup, 89
- PG Position, 31
- PG Settings, 38
- PG Speed, 31
- PG Speed Frequency #1, 90
- PG Speed Frequency #2, 90
- PG Speed Reference #1, 89
- PG Speed Reference #2, 90
- Phase Loss, 37
- PID feedback, 108, 155
- PID Value, 30
- POFF, 170
- Position Completion Range, 111
- Position Difference Limit (Droop Pulses Allowed), 148
- Position Loop Gain, 110
- Positional Err, 175
- Post Compensation Frequency, 30
- Power Running Torque Limit #1, 121
- PP, 8, 10
- Preferences, 32
- Preset Speed #1, 52
- Preset Speed #10, 97
- Preset Speed #11, 97
- Preset Speed #12, 97
- Preset Speed #13, 97
- Preset Speed #14, 97
- Preset Speed #15, 97
- Preset Speed #2, 52
- Preset Speed #3, 53
- Preset Speed #4, 53
- Preset Speed #5, 53
- Preset Speed #6, 53
- Preset Speed #7, 53
- Preset Speed #8, 96
- Preset Speed #9, 96
- Preset Speed Direction #1, 112
- Preset Speed Direction #10, 114
- Preset Speed Direction #11, 114
- Preset Speed Direction #12, 114
- Preset Speed Direction #13, 114
- Preset Speed Direction #14, 114
- Preset Speed Direction #15, 115
- Preset Speed Direction #2, 112
- Preset Speed Direction #3, 113
- Preset Speed Direction #4, 113
- Preset Speed Direction #5, 113
- Preset Speed Direction #6, 113
- Preset Speed Direction #7, 113
- Preset Speed Direction #8, 113
- Preset Speed Direction #9, 114
- Preset Speed Mode, 36, 39
- Preset Speeds, 35, 39
- Program Menu Navigation, 32

- Program Mode, 32
- Prohibit Initializing User Parameters During Typeform Initialization, 154
- Proportional (P) Gain, 109
- Proportional-Integral-Derivative (PID), 108
- Protection Parameters, 36
- PtSt, 170
- PWM Carrier Frequency, 98

Q

- Qualified Personnel, 2

R

- R, 8, 9
- R Input Terminal Assignment, 57
- R Input Terminal Delay, 64
- R/F Priority Selection, 55
- RAM Err, 175
- Reach Settings, 34
- Realtime Clock Setup, 32
- Reference Priority Selection, 73
- Regeneration Torque Limit #1, 121
- Regeneration Torque Limit #2, 122
- Regeneration Torque Limit #3, 122
- Regeneration Torque Limit #4, 122
- Regeneration Torque Limit Setting #1, 121
- Release After Run Timer (brake), 148
- RES, 8, 9
- RES Input Terminal Assignment, 58
- RES Input Terminal Delay, 64
- Reset, 47
- Reset Key, 17
- Retry/Restart Configuration, 36
- Reverse Speed Limit Input, 119
- Reverse Speed Limit Level, 119
- Review Startup Screen, 33
- Ridethrough Mode, 99
- ROM Err, 175
- Root Menus, 29
- Rotary Encoder, 17
- RR, 8, 9, 31
- RR Bias Adjust, 124
- RR Gain Adjust, 124
- RR Input Speed Control Setup, 78
- RR Input Torque Control Setup, 78
- RR Speed Frequency #1, 79
- RR Speed Frequency #2, 79
- RR Speed Reference #1, 78
- RR Speed Reference #2, 79
- RR Torque Reference Setpoint #1, 79
- RR Torque Reference Setpoint #2, 80
- RS232, 12
- RS232/RS485 Baud Rate, 160
- RS232/RS485 Communications Time Out Time, 157
- RS232/RS485 Communications Time-Out Action, 158
- RS232/RS485 Master Output, 161
- RS232/RS485 Response Delay Time, 161
- RS232/RS485 Wire Count, 161
- RS485, 12
- Run Frequency, 30, 91
- Run Frequency Hysteresis, 91
- Run Key, 18
- Run LED, 18
- RX, 8, 10, 31
- RX Bias Adjust, 124
- RX Gain Adjust, 125
- RX Input Speed Control Setup, 81
- RX Input Torque Control Setup, 81
- RX Speed Frequency #1, 82
- RX Speed Frequency #2, 82
- RX Speed Reference #1, 81
- RX Speed Reference #2, 82
- RX Torque Reference Setpoint #1, 82
- RX Torque Reference Setpoint #2, 83
- RX2, 31
- RX2 Bias Adjust, 125
- RX2 Gain Adjust, 125
- RX2 Input Speed Control Setup, 84
- RX2 Input Torque Control Setup, 84
- RX2 Speed Frequency #1, 85
- RX2 Speed Frequency #2, 85
- RX2 Speed Reference #1, 84
- RX2 Speed Reference #2, 85
- RX2 Torque Reference Setpoint #1, 85
- RX2 Torque Reference Setpoint #2, 86

S

- S1, 8, 9
- S1 – S4 Input Terminal Delay, 64
- S1 Input Terminal Assignment, 58
- S2, 8, 9
- S2 Input Terminal Assignment, 58
- S3, 8, 9
- S3 Input Terminal Assignment, 58
- S4, 8, 9
- S4 Input Terminal Assignment, 59
- S5 – S16 Input Terminal Delay, 64
- S5 Input Terminal Assignment, 59
- S6 Input Terminal Assignment, 59
- S7 Input Terminal Assignment, 60
- Scrolling Monitor Select, 42
- Service Life Information, 6

- Short Circuit Detect Pulse, 37
- Short Circuit Test, 145
- Short Circuit Test Duration, 145
- Sink/Source Error, 175
- Soft Stall, 51
- Soft Stall Enable, 37
- Soft Start, 37
- S-pattern 1, 129
- S-pattern 2, 129
- S-Pattern Lower Limit Adjustment, 130
- S-Pattern Upper Limit Adjustment, 130
- Special Control Parameters, 42
- Special Parameters, 43
- Speed at Drooping Gain 0%, 103
- Speed at Drooping Gain 100%, 103
- Speed Drop Detection Frequency Range, 147
- Speed Error, 174
- Speed Limit (torque) Reference, 120
- Speed Limit Torque Level, 120
- Speed Limit Torque Range, 120
- Speed Limit Torque Recovery, 120
- Speed Loop Integral Gain, 111
- Speed Loop Parameter Ratio, 112
- Speed Loop Proportional Gain, 111
- Speed Reach Frequency, 54
- Speed Reach Frequency Tolerance, 54
- Speed Ref. Setpoint, 35
- Speeds, 39
- ST, 8, 9
- ST Input Terminal Assignment, 58
- ST Input Terminal Delay, 64
- ST Signal Selection, 55
- Stall, 36
- Stall Cooperation Gain at Field Weakening Zone, 126
- Stall Prevention During Regeneration, 123
- Standard Mode Settings, 32
- Startup Frequency, 90
- Startup Wizard, 32
- Startup Wizard Requirements, 21
- Stop Pattern, 154
- Stop/Reset Key, 17
- SW1, 11
- SW2, 11
- Switching Frequency of Current/Voltage Control, 127
- Switching Load Torque During Forward-Run, 105
- Switching Load Torque During Reverse-Run, 106
- Synchronized Torque Bias Input, 117
- System Configuration, 29
- System Operation, 19

T

- Tension, 118
- Tension Torque Bias Input, 118
- Terminal Board, 8
- Terminal Descriptions, 9
- Terminal Selection Parameters, 34
- Time Setting, 32
- Timer, 30
- Torque, 30
- Torque Boost Adjustment, 150
- Torque Command, 117
- Torque Command Filter, 117
- Torque Command Mode, 119
- Torque Control, 38
- Torque Current, 30
- Torque Limit Group, 155
- Torque Limit Mode, 122
- Torque Limit Mode (Speed Dependent), 123
- Torque Limit Settings, 38
- Torque Reference, 30
- Torque Setting Parameters, 37
- Torque Speed Limiting, 38
- Trip History, 42, 176
- Trip Monitor from ASD, 42
- Trip Record at Monitor Screen, 176
- Trip Save at Power Down Enable, 142
- Trip Settings, 37
- Trips, 168
- Trouble Shooting, 168
- TTL Master Output, 158
- Type Reset, 33, 47
- Type(form) Error, 175

U

- U Phase OC, 175
- UC, 171
- Under Curr(ent) Trip, 173
- Undervoltage Detection Time, 147
- Undervoltage Stall level, 148
- Undervoltage Trip, 147
- Undervoltage/Ridethrough, 37
- Up Key, 17
- Upper Deviation Limits, 109
- Upper Limit Frequency, 21, 49
- Upper Limit Frequency Adjustment, 149
- Use Speed Mode, 112
- User Notification codes, 168
- Utility Parameters, 33

V

- V Phase OC, 175
- V/f Adjustment, 43
- V/f Adjustment Coefficient, 71
- V/f Five Point Setting, 43
- V/f Group, 154
- V/f Pattern, 50
- Vector Motor Model, 41
- Vector Motor Model Autotune Command, 115
- Vector Motor Model Slip Frequency Gain, 115
- Versions, 33
- VI, 8, 10
- VI/II, 31
- VI/II Bias Adjust, 123
- VI/II Gain Adjust, 124
- VI/II Input Speed Control Setup, 74
- VI/II Input Torque Control Setup, 74
- VI/II Speed Frequency #1, 75
- VI/II Speed Frequency #2, 75
- VI/II Speed Reference #1, 74
- VI/II Speed Reference #2, 75
- VI/II Torque Reference Setpoint #1, 75
- VI/II Torque Reference Setpoint #2, 76
- Viewing Trip Information, 176
- Voltage Compensation Coefficient for Dead Time, 127
- Voltage Vector Control, 126
- Volts per Hertz, 22

W

- W Phase OC, 175
- Wizard Finish, 23

TOSHIBA

TOSHIBA INTERNATIONAL CORPORATION

INDUSTRIAL DIVISION

13131 West Little York Road, Houston, TX 77041

TEL: (713) 466-0277 — FAX: (713) 466-8773

Printed in the U.S.A.