

TOSHIBA

DIGITAL TRANSISTOR INVERTER

Q-FLOWSAVER SERIES

THE **QUIET** TRANSISTOR INVERTER

TOSHIBA

OPERATION MANUAL

September, 1996
Part #44210-000



NOTE

The instructions contained in this manual are not intended to cover all of the details or variations in equipment, nor to provide for every possible contingency to be met in connection with installation, operation, or maintenance. Should further information be desired or should particular problems arise which are not covered sufficiently for the purchaser's purposes, the matter should be referred to the local Toshiba sales office.

The contents of this instruction manual shall not become a part of or modify any prior or existing agreement, commitment, or relationship. The sales contract contains the entire obligation of Toshiba International Corporation's Inverter Division. The warranty contained in the contract between the parties is the sole warranty of Toshiba International Corporation's Inverter Division and any statements contained herein do not create new warranties or modify the existing warranty.

Any electrical or mechanical modification to this equipment, without prior written consent of Toshiba International Corporation, will void all warranties and may void UL/CUL listing.

AC ADJUSTABLE SPEED DRIVE

Please complete the Extended Warranty Card supplied with this inverter and return it by prepaid mail to Toshiba. This activates the extended warranty. If additional information or technical assistance is required call Toshiba's marketing department toll free at (800) 231-1412 or write to: Toshiba International Corporation, 13131 W. Little York Road, Houston, TX 77041-9990.

Please complete the following information for your records and to remain within this equipment manual:

Model Number: _____

Serial Number: _____

Date of Installation: _____

Inspected By: _____

Reference Number: _____

INTRODUCTION

Thank you for purchasing the **FLOWQSU Series**. This adjustable frequency solid state AC drive features low acoustical noise, pulse width modulation, digital control, and user programmability. The very latest microprocessor and insulated gate bipolar transistor technology is used. This, combined with Toshiba's high performance software, gives unparalleled motor control and reliability.

It is the intent of this operation manual to provide a guide for **safely** installing, operating, and maintaining the drive. This operation manual contains a section of general safety instructions and is marked throughout with warning symbols. **Read this operation manual** thoroughly before installation and operation of this electrical equipment.

All safety warnings must be followed to ensure personal safety.

Follow all precautions to attain proper equipment performance and longevity.

The manual is divided into major sections of interest. All of the initial inspection, storage, installation and operating precautions can be found in Sections 1 and 2 with Section 3 and 4 containing all of the standard specifications and information on grounding, wiring, and cable sizes.

Section 5 contains information about the printed circuit board layouts, connectors, wiring jumpers, and connector functions.

Section 6 shows layout information about the keypad panel and readouts.

Sections 7, 8, 9, 10, and 11 are devoted to the functional parameter groups, functional parameter access and operation, status monitoring, and input and output terminal functions.

Section 12 contains a problem sheet showing the necessary information for after sales service and recommended parts service life.

Section 13 contains shipping weights and dimensional data.

We hope that you find this operation manual informative and easy to use. If additional information or technical assistance is needed, please call toll free (800) 231-1412 or write to: Toshiba International Corporation, 13131 W. Little York Road, Houston, TX 77041-9990.

Again thank you for the purchase of this product.

COPYRIGHT © SEPTEMBER, 1996 TOSHIBA INTERNATIONAL CORPORATION

GENERAL SAFETY INSTRUCTIONS

Warnings in this manual appear in either of two ways:

- 1) *Danger warnings* - The danger warning symbol is an exclamation mark enclosed in a triangle which precedes the 3/16" high letters spelling the word "DANGER". The Danger warning symbol is used to indicate situations, locations, and conditions that can cause serious injury or death:



- 2) *Caution warnings* - The caution warning symbol is an exclamation mark enclosed in a triangle which precedes the 3/16" high letters spelling the word "CAUTION". The Caution warning symbol is used to indicate situations and conditions that can cause operator injury and/or equipment damage:



Other warning symbols may appear along with the *Danger* and *Caution* symbol and are used to specify special hazards. These warnings describe particular areas where special care and/or procedures are required in order to prevent serious injury and possible death:

- 1) *Electrical warnings* - The electrical warning symbol is a lightning bolt mark enclosed in a triangle. The Electrical warning symbol is used to indicate high voltage locations and conditions that may cause serious injury or death if the proper precautions are not observed:



- 2) *Explosion warnings* - The explosion warning symbol is an explosion mark enclosed in a triangle. The Explosion warning symbol is used to indicate locations and conditions where molten, exploding parts may cause serious injury or death if the proper precautions are not observed:



For the purpose of this manual and product labels, a **Qualified Person** is one who is familiar with the installation, construction, operation and maintenance of the equipment and the hazards involved. In addition, this person must:

- 1) Carefully read the entire operation manual.
- 2) Be trained and authorized to safely energize, de-energize, clear faults, ground, lockout and tag circuits and equipment in accordance with established safety practices.
- 3) Be trained in the proper care and use of protective equipment such as safety shoes, rubber gloves, hard hat, safety glasses, face shields, flash clothing, and etc. in accordance with established safety practices.
- 4) Be trained in rendering first aid.

CONTENTS

<u>SECTION</u>	<u>PAGE</u>
Disclaimer	i
Introduction	ii
General Safety Instructions	iii
Contents	iv-vi
1.0 Inspection/Storage/Disposal	1-1
1.1 Inspection of the New Unit	1-1
1.2 Storage	1-1
1.3 Disposal	1-1
2.0 Safety in Installation and Operation	2-1
2.1 Installation Precautions	2-1
2.2 Operating Precautions	2-2
2.3 Confirmation of Wiring	2-3
2.4 Start-up and Test	2-3
2.5 Maintenance	2-3
3.0 Standard Specifications	3-1
4.0 Wiring	4-1
4.1 Simple Connection Diagrams	4-1
4.2 Selection of Main Circuit Wiring Equipment and Standard Cable Sizes	4-3
4.3 Grounding	4-4
5.0 PWB Layout, Jumpers, and Terminal Connections	5-1
5.1 Control/Driver Board for FLOWQSU Models 2035 through 2330 ...	5-1
5.2 Control/Driver Board for FLOWQSU Models 4055 through 4330 ...	5-2
5.3 Control Board for FLOWQSU Models 4400 through 410K	5-3
5.4 Driver Board for FLOWQSU Models 4400 through 410K	5-4
5.5 Jumper Details	5-5
5.6 Control/Driver Board Terminal Block Details	5-5
5.7 Jumper/Terminal Connections and Functions	5-6
5.8 Terminal Connections and Functions	5-7

CONTENTS (cont'd)

<u>SECTION</u>	<u>PAGE</u>
6.0 Operating Panel	6-1
6.1 Operating Panel Layout	6-1
6.2 Operating Panel Keys and Functions	6-1
6.3 LED Display and Display Monitoring.....	6-3
6.4 Display Alphanumerics	6-4
7.0 Parameter Groups	7-1
7.1 Definitions of Setup and Group Parameters	7-1
7.2 System Parameters Adjustment Range and Factory Settings	7-2
8.0 System Status Monitoring	8-1
8.1 Normal Status Monitoring	8-1
8.2 Automatic Status Monitoring	8-2
8.3 Tripped Status Monitoring.....	8-3
8.4 Input Terminal Status Code	8-4
8.5 Output Terminal Status Code	8-5
9.0 Keypad Operating Functions	9-1
9.1 Setup Parameters	9-1
9.2 User Group Parameters	9-3
9.3 Communication Group Parameters	9-5
9.4 Jump Frequency Group Parameters.....	9-7
9.5 Display Group Parameters	9-8
9.7 Speed Group Parameters	9-9
9.8 Pattern Frequency Group Parameters	9-10
10.0 Input Terminal Operating Functions	10-1
10.1 Input Terminal Selection Function	10-1
10.2 Starting/Stopping-Remote Control	10-2
10.3 Remote Control Frequency Setting	10-2
10.4 Jog	10-3
10.5 Resetting After a Trip	10-3
10.6 Pattern Run.....	10-4
10.7 PID Set Point Control.....	10-5
11.0 Output Terminal Operating Functions	11-1
11.1 Selectable Outputs	11-1
11.2 Inverter to Relay/PC Connections	11-2
11.3 Fault Detection Output Terminals	11-2
11.4 Calibration of Remote Meters	11-3

CONTENTS (cont'd)

<u>SECTION</u>	<u>PAGE</u>
12.0 After Sales Service/Service Life	12-1
12.1 Requesting after sales service	12-1
12.2 Parts Service Life	12-2
13.0 Dimensions/Weights	13-1
13.1 Basic Dimensions	13-1
13.2 Operating Panel Assembly	13-3
13.3 Shipping Weights	13-4

1.0 Inspection/Storage/Disposal

1.1 Inspection of the New Unit

Upon receipt of the QSeries inverter, a careful inspection for shipping damage should be made. After uncrating:

- 1) Check the unit for loose, broken, bent or otherwise damaged parts due to shipping.
- 2) Check to see that the rated capacity and the model number specified on the nameplate conform to the order specifications.

1.2 Storage

- 1) Store in a well ventilated location and preferably in the original carton if the inverter will not be used immediately after purchase.
- 2) Avoid storage in locations with extreme temperatures, high humidity, dust, or metal particles.

1.3 Disposal

Please contact your state environmental agency for details on disposal of electrical components and packaging in your particular area. ***Never dispose of these electrical components in fire.***



2.0 Safety in Installation and Operation

2.1 Installation Precautions CAUTION



- 1) Install in a secure and upright position in a well ventilated location where the ambient temperature is between -10 deg C and 40 deg C (up to 50 deg C when not enclosed in a cabinet). Do not allow direct sunlight to shine on the unit or obstruct ventilating openings.
- 2) Allow a clearance space of 4 inches (10 cm) for the top and bottom and 2 inches (5 cm) on both sides. This space will insure adequate ventilation.
- 3) Avoid installation in areas where vibration, heat, humidity, dust, steel particles, or sources of electrical noise are present.
- 4) Adequate working space should be provided for adjustment, inspection and maintenance.
- 5) Adequate lighting should be available for troubleshooting and maintenance.
- 6) A noncombustible insulating floor or mat should be provided in the area immediately surrounding the electrical system where maintenance is required.
- 7) ***Use separate metal conduits for routing the input power, output power, and control circuits.***
- 8)  Always ground the unit to prevent electrical shock and to help reduce electrical noise. A separate ground cable should be run inside the conduit with the input, output, and control power cables. ***The metal of the conduit is not an acceptable ground.***
- 9) Connect three phase power of the correct voltage to input terminals L1, L2, L3 (R, S, T) and connect three phase power from output terminals T1, T2, T3 (U, V, W) to a motor of the correct voltage and type for the application. Size the conductors in accordance with Article 310 of the National Electrical Code.
- 10) If conductors of a smaller than recommended size are used in parallel to share current then the conductors should be kept together in as sets i.e. U1, V1, W1 in one conduit and U2, V2, W2 in another. National and local electrical codes should be checked for possible cable derating factors if more than three power conductors are run in the same conduit.
- 11) Install a molded case circuit breaker (MCCB) between the power source and the inverter. Size the MCCB to clear the available fault current of the power source.
- 12) Installation of inverter systems should conform to the *National Electrical Code*, regulations of the *Occupational Safety and Health Administration*, all national codes, and all regional or industry codes and standards.
- 13) ***Only qualified personnel should install this equipment.***

2.2 Operating Precautions CAUTION

- 1) Do not apply power and attempt to use the inverter until this entire operation manual has been carefully reviewed.
- 2) The input voltage must be within +/-10% of the specified input voltage. Voltages outside of this permissible tolerance range may cause internal protection devices to turn on or can cause damage to the unit. Also, the input frequency should be within +/-2 Hz of the specified input frequency.
- 3) Do not use this inverter with a motor whose rated input is greater than the rated inverter output.
- 4) This inverter is designed to operate NEMA B motors. Consult the factory before using the inverter for special applications such as an explosion proof motor or one with a repetitive type piston load.

- 5)  **DANGER**  Do not touch any internal part with power applied to the inverter. First remove the source power and check that the charge and power LED's are out. **A hazard exists temporarily for electrical shock even if the source power is removed.**

- 6) Do not apply commercial power to the output terminals T1 (U), T2 (V), or T3 (W) even if the inverter source power is off. Disconnect the inverter from the motor before applying a test or bypass voltage to the motor.

- 7)   Do not operate this unit with the cabinet door open.

- 8) Use caution when setting output frequency. Overspeeding of the motor can cause serious damage to the motor and/or the driven load equipment.
- 9) Use caution when setting the acceleration and/or deceleration time. Unnecessarily short acc/dec time can cause undue stress and tripping of the drive.
- 10) Interface problems can occur when this inverter is used in conjunction with some types of process controllers. **Signal isolation may be required to prevent controller and/or inverter damage.**

Contact Toshiba or the process controller manufacturer for further information about compatibility and signal isolation.

- 11) **Only qualified personnel should have access to the adjustments and operation of this equipment.** They should be familiar with the drive operating instructions and with the machinery being driven.
- 12) **Only properly trained and qualified personnel should be allowed to service this equipment.**
- 13) **Follow all warnings and precautions; do not exceed equipment ratings.**

2.3 Confirmation of Wiring CAUTION

Make the following final checks before applying power to the unit:

- 1) Confirm that source power is connected to terminals L1, L2, L3 (R, S, T).
Connection of incoming source power to any other terminals will damage the inverter.
- 2) The 3-phase source power should be within the correct voltage and frequency tolerances.
- 3) The motor leads must be connected to terminals T1, T2, T3 (U, V, W).
- 4) Make sure there are no short circuits or inadvertent grounds and tighten any loose connector terminal screws.

2.4 Start-Up and Test CAUTION

Prior to releasing an electrical drive system for regular operation after installation, the system should be given a start-up test by competent personnel. This assures correct operation of the equipment for reasons of reliable and safe performance. It is important to make arrangements for such a check and that time is allowed for it.

When power is applied for the first time the inverter will come up in the factory settings (See section 7.2). If these settings are incorrect for the application trial run then the correct settings should be programmed from the control panel before activating the run button. **The inverter can be operated with no motor connected.** Operation with no motor connected or use with a small trial motor is recommended for initial adjustment or for learning to adjust and operate the inverter.

2.5 Maintenance CAUTION

- 1) Periodically check the operating inverter for cleanliness.
- 2) Keep the heatsink free of dust and debris.
- 3)  Periodically check electrical connections for tightness. **(make sure power is off and locked out).**

3.0 Standard Specifications

* FLOWQSU MODELS	RATINGS					
	RATED KVA	OUTPUT CURRENT AMPS	OUTPUT VOLTAGE 3-PHASE	OVERLOAD CURRENT	MAIN CIRCUIT INPUT VOLTAGE 3-PHASE	CONTROL CIRCUIT SINGLE PHASE
2035	3.5	9.6	200-230V 3-PHASE (MAX OUTPUT VOLTAGE UNDER NO LOAD)	120% FOR 60 SEC. 110% CONTINUOUS	200V@50Hz or 200-230V@60Hz VOLT ±10% Hz ±2Hz	NO EXTERNAL CONTROL SOURCE REQUIRED
2055	5.5	15.2				
2080	8	22				
2110	11	28				
2160	16	42				
2220	22	54				
2270	27	68				
2330	33	80				
4055	5.5	7.6	380-460V 3-PHASE (MAX OUTPUT VOLTAGE UNDER NO LOAD)		380V@50Hz or 400-460V@60Hz VOLT +/-10% Hz +/-2Hz	
4080	8	11				
4110	11	14				
4160	16	21				
4220	22	27				
4270	27	34				
4330	33	40				
4400	40	52				
4500	50	65				
4600	60	77				
4800	80	96				
410K	100	124				

* All of these models are UL (Underwriters Laboratories Inc.) listed and CUL (Canadian Underwriters Laboratories Inc. listed).

3.0 Standard Specifications (cont'd)

ITEM		STANDARD SPECIFICATIONS
Control	Control Method	Sinusoidal PWM control
	Output voltage regulation	Same as power line.
	Output frequency	0.0 to 160.0 Hz (0.0 to 60 Hz setting when shipped); maximum frequency range is 30 to 160 Hz *1
	Frequency setting resolution	0.1Hz: Operating panel input; 0.03 Hz: Analog input; 0.01Hz: Input through computer interface (against a 60 Hz)
	Frequency accuracy	±0.5% (at 25°C; ±10°C) against the maximum frequency
	Voltage/frequency characteristics	Second-order nonlinear mode for variable torque. "Max voltage" frequency adjustment (25 to 160 Hz), torque boost adjustment (0 to 30 %), start-up frequency adjustment (0 to 10 Hz)
	Frequency setting signals	3k ohms potentiometer (a 1k to 10k ohms-rated potentiometer can be connected). 0 to 10 Vdc (input impedance: 30k ohms), 0 to 5 Vdc (15k ohms), 4 to 20 mAdc (250 ohms)
	Output frequency characteristics of IV terminal input signal	Can be set to an arbitrary characteristic by setting 2 points.
	Frequency jump	3-point setting; setting jump frequency and band width
	Upper/lower limit frequencies	Upper limit frequency: 0.0 Hz to maximum frequency Lower limit frequency: 0.0 Hz to upper limit frequency
PWM carrier frequency switching	Adjusted in the range of 5 kHz to 8 kHz	
Operating functions	Acceleration/deceleration time	0.1 to 1200 seconds, switching of acceleration time 1 or 2, selection of S-shaped 1 or 2, or selection of acceleration/deceleration patterns
	Electrical braking	DC injection braking Start-up frequency adjustment (0 to 10 Hz), braking voltage adjustment (0 to 20 %), braking time adjustment (0 to 5 seconds)
	Forward or reverse run	Forward run when F-CC closed; reverse run when R-CC closed; reverse run when both F-CC and R-CC closed; coasting stop when ST-CC open; emergency coast stop by a command from operating panel
	Jogging run	Jogging run engaged when N.O. contact is closed. (adjustment range 0.0 to 20.0 Hz)
	Multispeed run	By opening and closing different combinations of CC, SS1, SS2, and SS3, the set speed or seven preset speeds can be selected.
	Automatic fault latch reset	When a protective function is activated, the system checks main circuit devices, and attempts the restart up to 5 times (activated when shipped)
	Soft stall	Sustains a run in overload mode (set at ON when shipped)
	Automatic restart	Smoothly recovers a normal run of a free-running motor utilizing motor speed detection control.
	Programmable RUN patterns	Allows setting of 7 different patterns of automatic operation
Protection	Protective functions	Stall prevention, current limit, overcurrent, overvoltage, short-circuit at load, load-end ground fault, undervoltage, momentary power interrupt, electronic thermal overload, main circuit overcurrent at start-up, load-end overcurrent at start-up, cooling fin overheat, and emergency stop. Provisions for external fault signal.
	Electronic thermal characteristics	Standard motor/constant torque V/f motor switching, and electronic thermal stall prevention activating level adjustment
	Reset	Resets inverter when N.O. contact is closed.

*1 Consult the factory for applications above 80 Hz.

3.0 Standard Specifications (cont'd)

ITEM		STANDARD SPECIFICATIONS	
Display	(4) 7-segment red LED digits with colon and decimal points	Output frequency/ OFF	Frequency range 0.0 to 160 Hz and OFF state
	(4) discrete green LED's	Warning indications	Stall preventive warning, overvoltage limit warning, overload warning, power-end undervoltage warning, DC main circuit undervoltage warning, setting errors, EEPROM abnormality, and data transfer abnormality warnings
		Fault indications	Overcurrent, overvoltage, load-end ground fault, overload, armature overcurrent at start-up, load-end overcurrent at start-up, heat sink overheat.
		Data and status	Inverter status (forward/reverse run, frequency set value, output current, etc.) and each set value
		Speed scaling	An arbitrary unit (revolution speed, linear velocity or the like) as well as output frequency can be displayed by use of an arbitrary multiplication factor
		Data storage	A number is assigned to each inverter (for 0 to 31 inverters).
		DC charge indicator	Main DC bus circuit capacitors charge indicator
(1) discrete red LED (located inside enclosure)			
Output signals	Fault detection signal	One form C contact (250 AC / 30 Vdc)	
	Low speed/reach signals	Open collector output (24 Vdc, 50 mA maximum)	
	Upper limit/lower limit frequency signals	Open collector output (24 Vdc, 50 mA maximum)	
	Frequency meter output and ammeter output	Ammeter rated at 1mAdc at full scale, or voltmeter rated at 7.5 Vdc, 1mA	
Enclosure type		NEMA Type 1 (standard)	
Cooling method		Convection-cooled FLOWQSU-2035 and 4055 Fan-cooled FLOWQSU2055 to 2330 and FLOWQSU4080 to 410K	
Color		Sherwin Williams Precision Tan #F63H12	
Service conditions	Service environment	Indoor, altitude 1000m (3,300 ft) maximum. Must not be exposed to direct sunlight, or subjected to corrosive or explosive gas or mists.	
	Ambient temperature	From -10 to 40°C (up to +50°C without the cover)	
	Relative humidity	95 % maximum (no condensation allowed)	
	Vibration	Acceleration at 0.5 G maximum (20 to 50 Hz), amplitude at 0.1 mm maximum (50 to 100 Hz)	

4.0 Wiring
4.1 Simple Connection Diagrams

**FLOWQSU SERIES
STANDARD CONNECTIONS
FOR MODELS 2035 TO 2330**

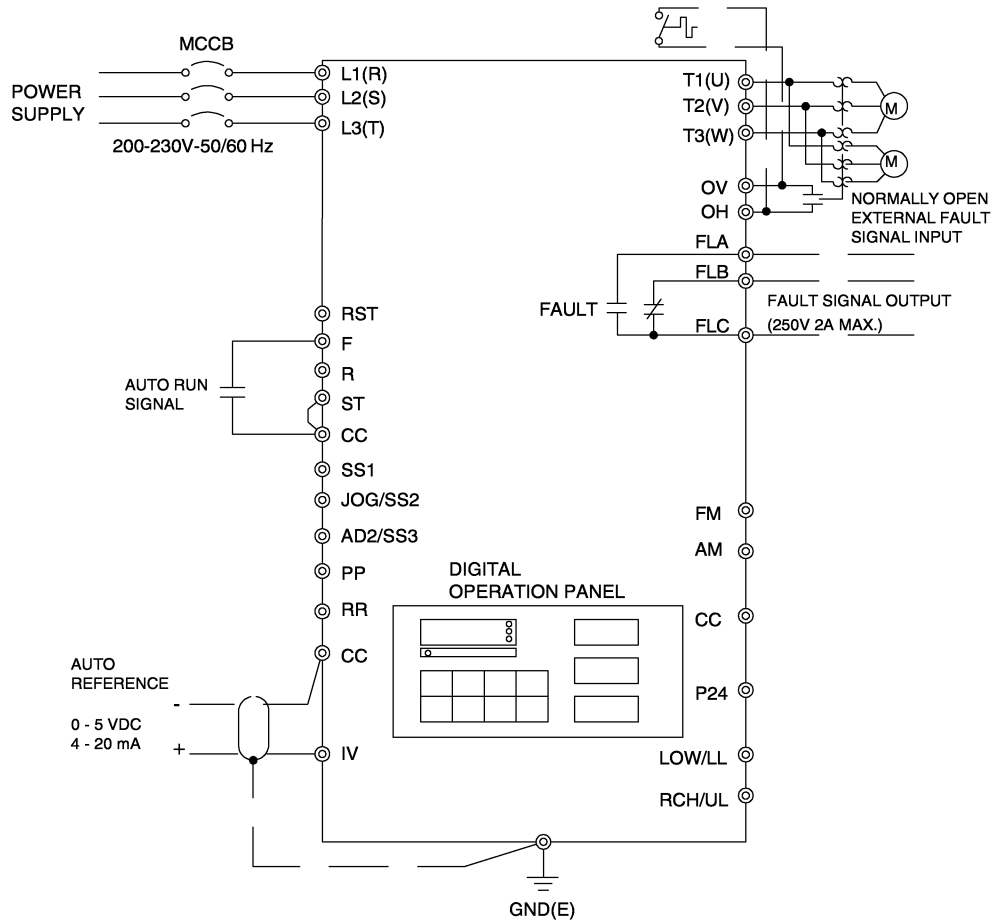

Notes:

- 1) For control/driver terminal block layout see Page 5-5.
- 2) For recommended wire sizes see Page 4-3.
- 3) For terminal connections and functions see Page 5-6 through 5-8.
- 4) Contact Toshiba when interfacing with a process controller.

4.0 Wiring (cont'd)

4.2 Selection of Main Circuit Wiring Equipment and Standard Cable Sizes

Inverter	*Molded case circuit breaker (MCCB)	Ampacity (FLA x 1.25)	**Typical cable size (AWG)				
			Type form	Amp rating (A)	(A)	Main power and motor load	Input / Output Lug Wire Capacity
FLOWQSU2035	20	13.8	#14	12-22 / 12-22	#14	3-core shield cable (speed reference) (speed reference) #20	#18
FLOWQSU2055	30	21.9	#12	12-22 / 12-22			
FLOWQSU2080	50	31.6	#10	2-14 / 2-18			
FLOWQSU2110	70	40	#8	2-14 / 2-18			
FLOWQSU2160	90	60	#6	2-14 / 2-18			
FLOWQSU2220	100	78	#4	2-14 / 2-18			
FLOWQSU2270	125	98	#3	2-14 / 2/0-14			
FLOWQSU2330	150	115	#2	250-6 / 250-6			
FLOWQSU4055	15	10.9	#14	12-22 / 12-22			
FLOWQSU4080	30	15.8	#14	12-22 / 12-22			
FLOWQSU4110	30	20.1	#12	2-14 / 2-18			
FLOWQSU4160	40	30.2	#10	2-14 / 2-18			
FLOWQSU4220	50	38.8	#8	2-14 / 2-18			
FLOWQSU4270	70	48.8	#8	2-14 / 2-18			
FLOWQSU4330	90	57.5	#6	2-14 / 2-18			
FLOWQSU4400	100	74.8	#4	2-14 / 2/0-14			
FLOWQSU4500	100	93.4	#3	2-14 / 2/0-14			
FLOWQSU4600	125	110.7	#2	250-6 / 250-6			
FLOWQSU4800	175	138	#1/0	250-6 / 250-6			
FLOWQSU410K	200	178.3	#2/0	250-6 / 250-6			

See next page for notes.

4.0 Wiring (cont'd)**4.2 Selection of Main Circuit Wiring Equipment and Standard Cable Sizes (cont'd)**

- * The customer supplied Molded Case Circuit Breaker (MCCB) or Magnetic Circuit Protector (MCP) should be coordinated with the available short circuit current. The units are rated for output short circuit faults of 5000A (1 - 50 HP), 10,000A (51 - 200 HP), and 18,000A (201 - 400 HP) according to the UL 508C "Power Conversion Equipment", Table 58.2 or CSA Standard C22.2 No.14-M1987 "Industrial Control Equipment" Table 24. The selection of breakers for this table is in accordance with 1990 NEC Article 430. The selection of these breakers takes into consideration motor starting at the low end of the output voltage specifications but does not consider the use of high efficiency motors.
- * For multiple motor applications, the magnetic only MCP should be replaced by a thermal magnetic MCCB. The MCCB should be sized according to 1.25 X (largest motor Full Load Amps) + (sum of all other motor Full Load Amps) to meet National Electric Code (NEC) or Canadian Electrical Code (CEC) requirements. An individual overload relay must be provided for each motor in multiple motor applications.
- ** Wire sizing is based upon NEC table 310-16 or CEC Table 2 using 75 deg C cable, an ambient of 30deg C, cable runs for less than 200 FT., and copper wiring for not more than three conductors in raceway or cable or earth (directly buried). The customer should consult the NEC or CEC wire Tables for his own particular application and wire sizing.
- ** For cable runs greater than 200 FT. between the motor and inverter, consult the factory before installing.

**CAUTION**

Use separate conduits for routing incoming power, power to motor, and control conductors. Use no more than three power conductors and a ground conductor per conduit.

Notes:

- 1.) Auxiliary relays used to switch inverter signals should be capable of switching low current signals (i.e. 5mA).
- 2.) The inverter has adjustable internal overload protection.

4.3 Grounding

The inverter should be grounded in accordance with Article 250 of the National Electrical Code or Section 10 of the Canadian Electrical Code, Part I and the grounding conductor should be sized in accordance with NEC Table 250-95 or CEC, Part I Table 16.

**CAUTION**

Conduit is not a suitable ground for the inverter.

5.0 PWB Layout, Jumpers, and Terminal Connections

5.1 Control/Driver Board for FLOWQSU Models 2035 through 2330

The following pictorial shows a layout of the major components located on the control/driver board VF3B-0100.

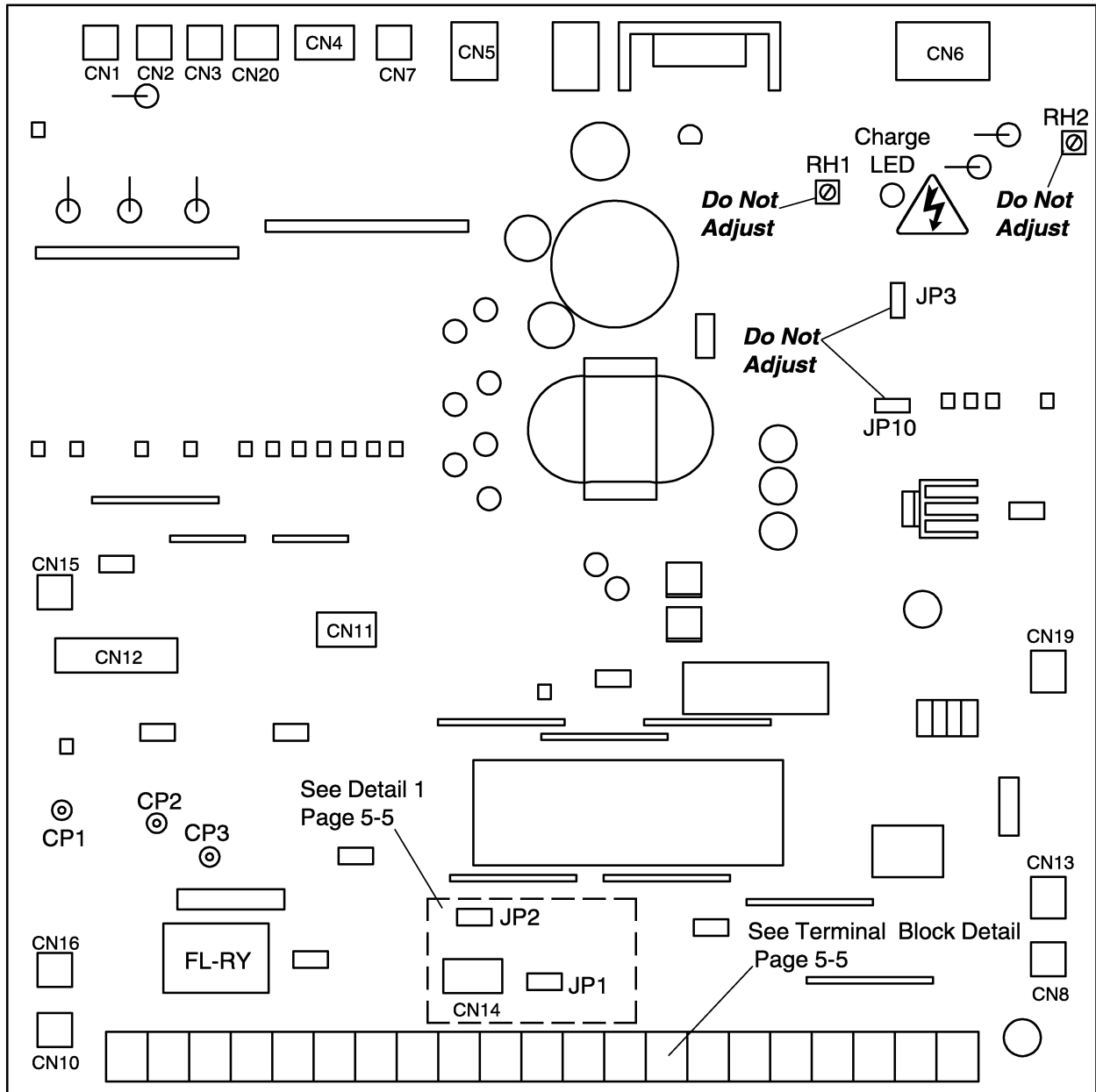

Note:

- 1) Potentiometer **RH1** is used for control power supply stabilization. This adjustment is factory set and any **ADJUSTMENT BY THE USER SHOULD NOT BE ATTEMPTED**.
- 2) Potentiometer **RH2** is used for voltage detection level bias. This adjustment is factory set and any **ADJUSTMENT BY THE USER SHOULD NOT BE ATTEMPTED**.
- 3) CP1, CP2, and CP3 are service testpoints.
- 4) **Do not adjust JP3 and JP10.**
- 5) Charge LED indicates charged capacitors. **DO NOT TOUCH internal parts if lighted.**

5.2 Control/Driver Board for FLOWQSU Models 4055 through 4500

The following pictorial shows a layout of the major components located on the control/driver board VF3B-0101.

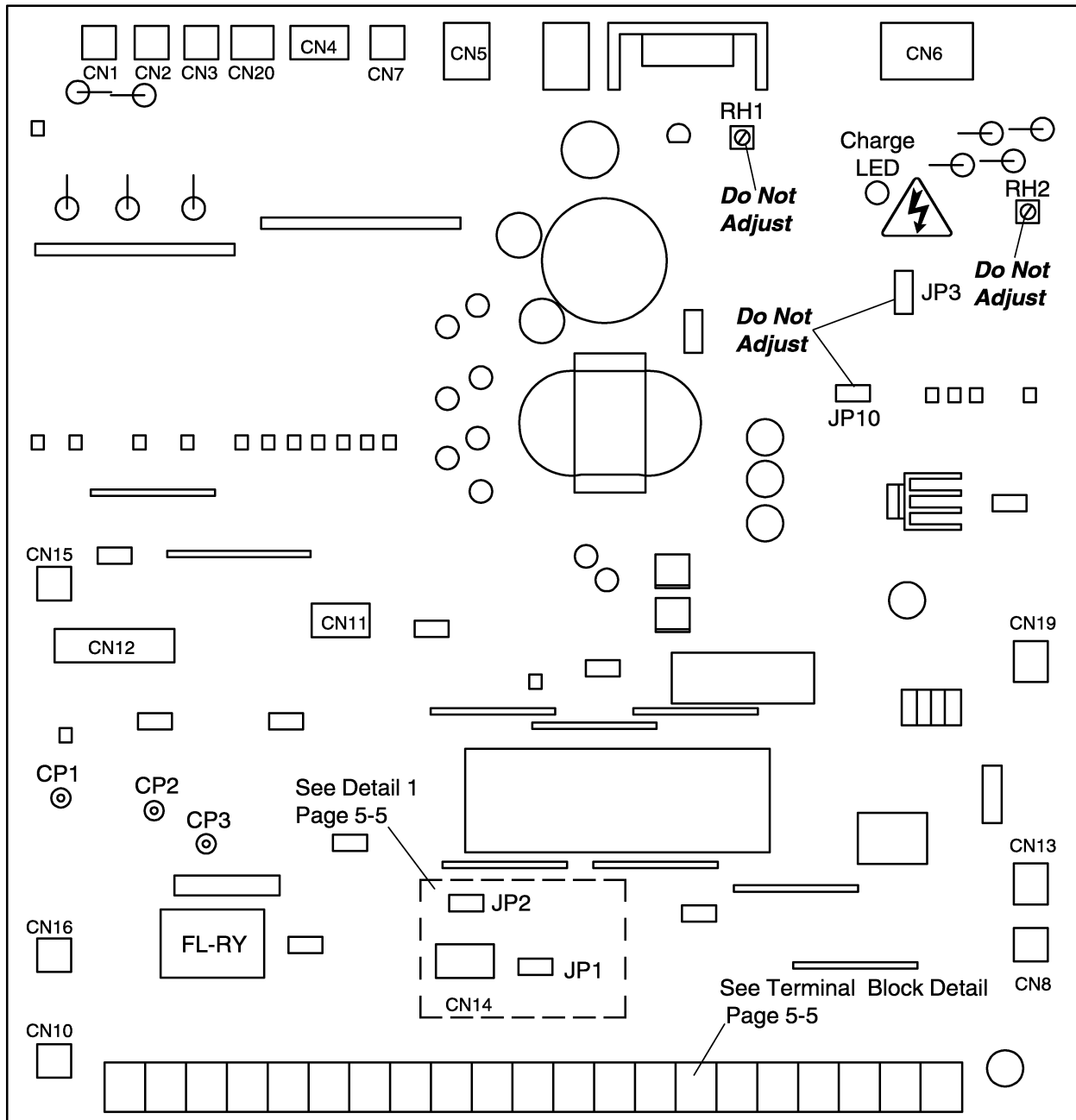

Note:

- 1) Potentiometer **RH1** is used for control power supply stabilization. This adjustment is factory set and any **ADJUSTMENT BY THE USER SHOULD NOT BE ATTEMPTED**.
- 2) Potentiometer **RH2** is used for voltage detection level bias. This adjustment is factory set and any **ADJUSTMENT BY THE USER SHOULD NOT BE ATTEMPTED**.
- 3) CP1, CP2, and CP3 are service testpoints.
- 4) **Do not adjust JP3 and JP10.**
- 5) Charge LED indicates charged capacitors. **DO NOT TOUCH internal parts if lighted.**

5.3 Control Board for FLOWQSU Models 4600 through 410K

The following pictorial shows a layout of the major components located on the control board VF3C-1200.

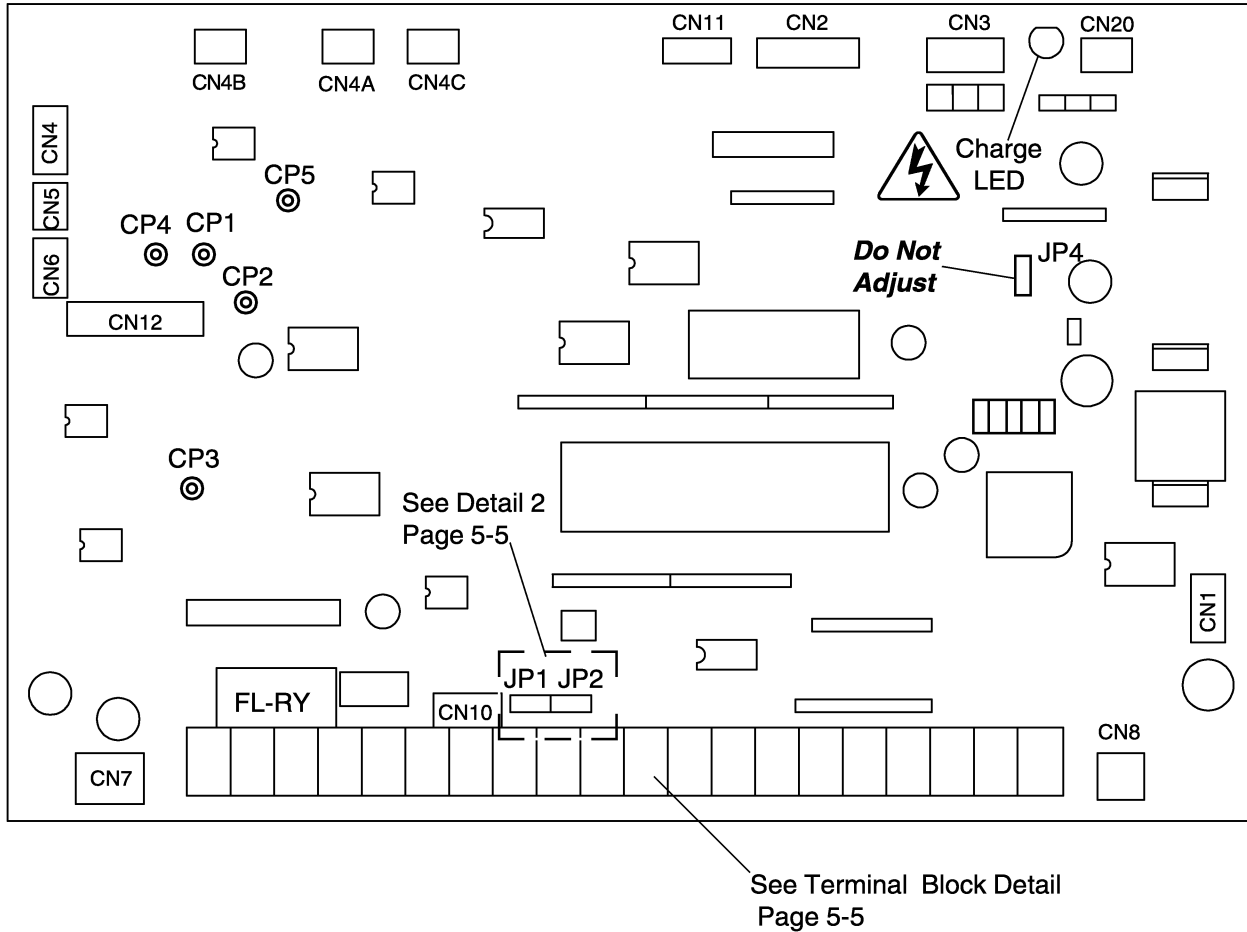

Note:

- 1) CP1, CP2, CP3, CP4, and CP5 are service testpoints.
- 2) **Do not adjust JP4.**
- 3) Charge LED indicates charged capacitors. **DO NOT TOUCH internal parts if lighted.**

5.4 Driver Board for FLOWQSU Models 4600 through 410K

The following pictorial shows a layout of the major components located on the driver board 35589.

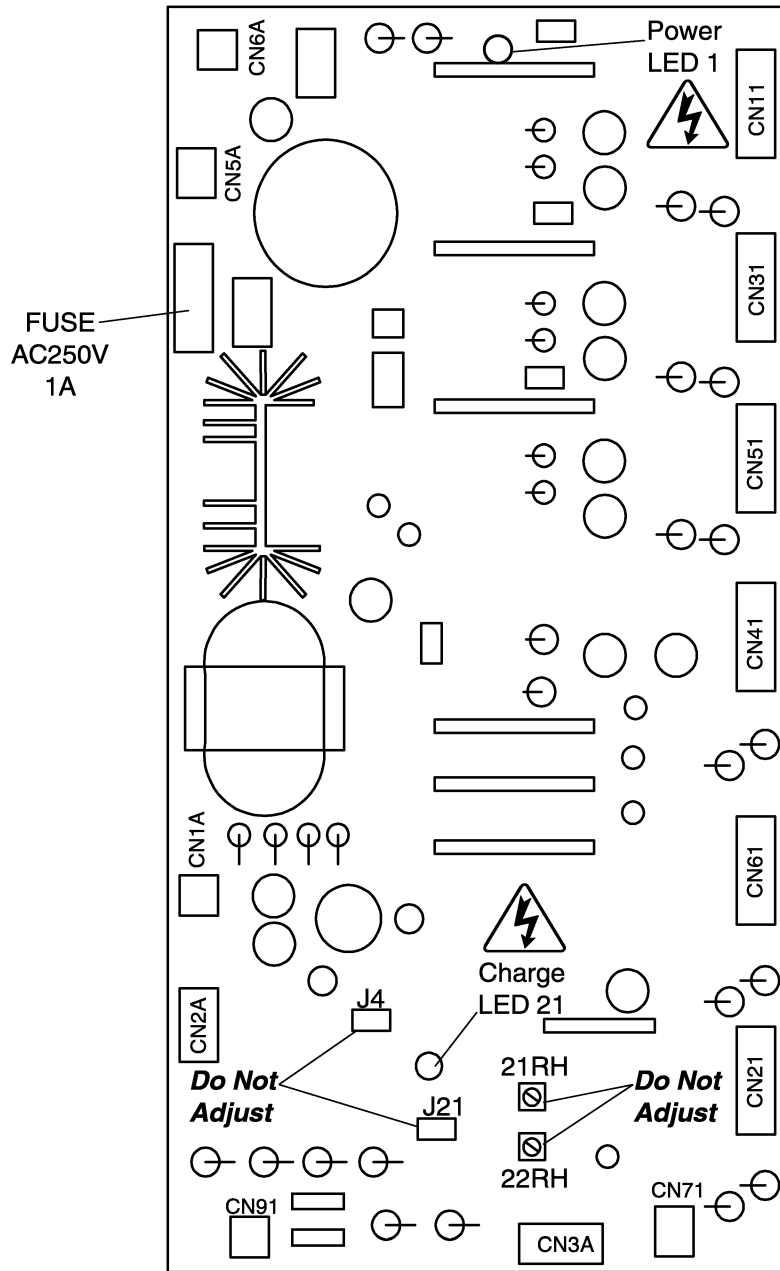

Note:

- 1) Potentiometer **21RH (OP)** is the main circuit overvoltage detection trip set. This adjustment is factory set and any **ADJUSTMENT BY THE USER SHOULD NOT BE ATTEMPTED.**
- 2) Potentiometer **22RH (MUV)** is the main circuit undervoltage detection trip set. This adjustment is factory set and any **ADJUSTMENT BY THE USER SHOULD NOT BE ATTEMPTED.**
- 3) **Do not adjust J4 and J21.**
- 5) Charge LED indicates charged capacitors. **DO NOT TOUCH internal parts if lighted.**

5.5 Jumper Details

The jumper connections for each of the printed wiring boards on Pages 5-1 through 5-3 are shown in the enlarged details below. **Only jumpers JP1 and JP2 should be adjusted by the user.** See Page 5-6 for jumper adjustments.

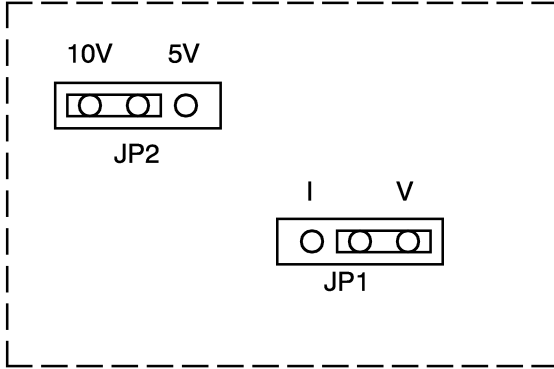

Detail 1 (Reference pages 5-1 and 5-2)

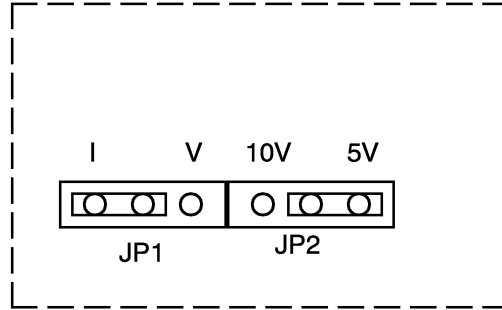

Detail 2 (Reference page 5-3)

4.9 Control/Driver Board Terminal Block Details

The control/driver board terminal block is shown in detail below. Each of the twenty-one terminals is functionally labeled. See Pages 5-7 and 5-8 for a list of terminal functions.

Control/Driver Board Terminal Block Detail (Reference pages 5-1, 5-2, and 5-3)

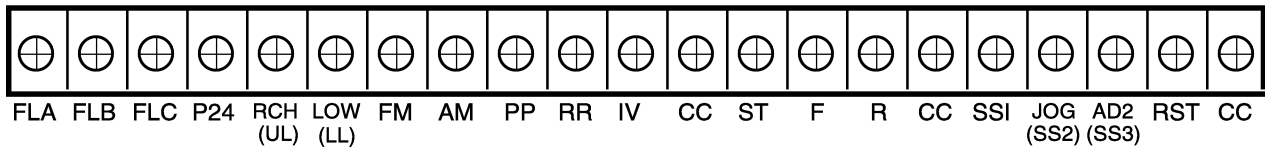

5.7 Jumper/Terminal Connections and Functions

The following table shows how jumpers JP1 and JP2 are set for use with the analog input terminal connections RR and IV. Jumper numbers and settings which are shown in this table are applicable to all printed wiring boards (see page 5-5 for terminal block and jumper details).

Terminal/Jumper Connections for Input Reference Signals

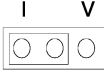
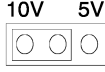
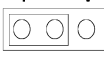
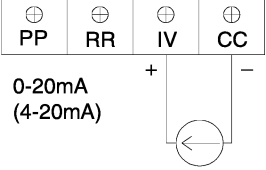
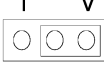
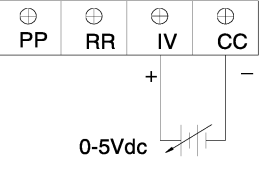
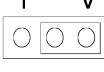
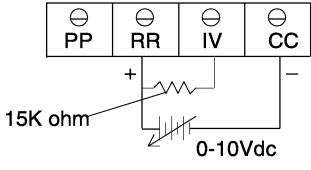
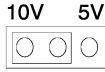
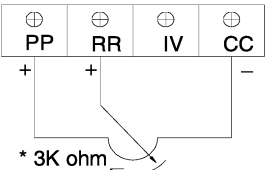
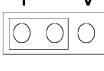
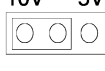
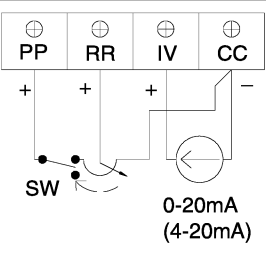
	JP1	JP2	Terminal Connections	Function
1			No external connections; JP1 and JP2 should be set as shown for keypad operation (normal factory setting).	Use when not inputting any external reference signals into terminal RR or IV. P.PrG parameter #2 "priority of RR terminal input" is N/A.
2		N/A		Use when inputting a 4(0)-20mA external reference signal to terminal IV. P.PrG parameter #2 "priority of RR terminal input" should be set to 0. See page 7-5.
3		N/A		Use when inputting 0-5Vdc external reference signal to terminal IV. P.PrG parameter #2 "priority of RR terminal input" should be set to 0. See page 7-5.
4		N/A		Use when inputting 0-10Vdc external reference signal to terminal RR. P.PrG parameter #2 "priority of RR terminal input" should be set to 0. See page 7-5.
5	N/A			Use when inputting 0-10Vdc external reference signal to terminal RR. P.PrG parameter #2 "priority of RR terminal input" should be set to 1. See page 7-5.
6				Use when inputting a 4(0)-20mA external reference signal to terminal IV and a 0-10Vdc reference signal to terminal RR. P.PrG parameter #2 "priority of RR terminal input" should be set to 1. Terminal RR will override "have priority over" terminal IV when switch (SW) is closed. See page 7-5.

*** 3K ohm pot divides voltage between terminal PP and CC return. Any pot value between 1K to 10K ohms can be used but makes adjustment more sensitive.**

5.8 Terminal Connections and Functions

Terminal name	Terminal functions	Terminal location
L1, L2, L3 (R, S, T)	Input power terminals. Connect to either a 3-phase 50Hz, 200Vac power supply or to a 3-phase 60Hz, 200 to 230Vac power supply for QSeries models QSU-2035 to QSU-2330.	Bus bar or power terminal block 
	Input power terminals. Connect to either a 3-phase 50HZ, 380Vac power supply or to a 3-phase 60HZ, 400 to 460Vac power supply for QSeries models QSU-4055 to QSU-410K.	
T1, T2, T3 (U, V, W)	Output load terminals. Connect these terminals to a 3-phase induction motor of the proper voltage.	
OH	Input terminal for external fault signal.	Terminal block
OV	This is the return terminal for OH.	
FLA, FLB, FLC	Output terminals of form C contact changes state when a protective function has been activated (250Vac - 2A).	Control PWB terminal block
P24	Output terminal for unregulated 24Vdc power supply (100mA maximum output current).	
RCH(UL)	Output terminal (open collector). Provides an output signal ground (50 mAdc max) when the upper limit frequency is reached, when an acc/dec is complete, or when the output frequency is within a specified range. The choice is determined by settings of the Output Terminal Selection function (:0.tb).	
LOW(LL)	Output terminal (open collector). Provides an output signal ground (50 mAdc max) when a preset low speed or a preset lower limit is reached. The choice is determined by settings of the Output Terminal Selection function (:0.tb).	
FM	Output terminal for an external analog frequency meter. Use either an ammeter rated at 1mAdc at full scale or a voltmeter rated at 7.5Vdc at full scale.	
AM	Output terminal for an external analog ammeter. Use either an ammeter rated at 1mAdc at full scale or a voltmeter rated at 7.5Vdc at full scale.	
PP	Regulated 10Vdc power supply to be used with terminal RR for remote terminal input.	
RR	Analog input terminal for a 0 - 5Vdc (JP2 @ 5V) or 0 - 10Vdc (JP2 @ 10V) external reference signal. Also used for wiring a 1k - 10k ohm (3k ohm recommended) potentiometer to allow for remote speed control operation.	
IV	Analog input terminal for a 0 - 5Vdc (JP1 @ V) or 4 (0) - 20mAdc (JP1 @ I) external reference signal.	
CC (one of three)	This is the common return for PP,RR, and IV terminals. Do not connect to GND(E).	

5.8 Terminal Connections and Functions (cont'd)

Terminal name	Terminal functions	Terminal location
ST	Input terminal for run interlock. When ST is shorted to CC, the inverter is ready to run. With ST-CC open the unit will not run and if opened while running a coasting stop begins.	Control PWB terminal block
F	Input terminal for forward run. When F is shorted to CC, a forward run starts. With F-CC open, the unit decelerates to a complete stop.	
R	Input terminal for reverse run. When R is shorted to CC, a reverse run starts. With R-CC open, the unit decelerates to a complete stop. <i>If terminals F-CC and R-CC are shorted simultaneously, a reverse run occurs.</i>	
CC (one of three)	This is the common return for ST terminal. <i>Do not connect to GND(E).</i>	
SS1	Input terminal for multi-speed run frequencies. Depends on setting of function [1.tb], JOG/SS2 and AD2/SS3 terminals. (See Page 10-1)	
JOG(SS2)	Input terminal for jogging run or multi-speed run frequencies. Depends on setting of function [1.tb], SS1, AD2(SS3) terminals. (See Page 10-1)	
AD2(SS3)	Input terminal for multispeed run frequencies. Depends on setting of function [1.tb], SS1, JOG/SS2 terminals. (See Page 10-1)	
RST	With RST-CC shorted, the inverter's protective function resets.	
CC (one of three)	This is the common return for ST, F, R, SS1, JOG(SS2), AD2(SS3), and RST terminals. <i>Do not connect to GND(E).</i>	
GND(E) (three provided)	The inverter earth ground terminal. <i>Do not connect to common return terminal (CC).</i>	Frame screw or lug
R41/46 *	Jumper to RJ when using 415V-50Hz/460V-60Hz incoming power. <i>Do not jumper to R40/44 or R38.</i>	Terminal block 
R40/44 *	Jumper to RJ when using 400V-50Hz/440V-60Hz incoming power. <i>Do not jumper to R41/46 or R38.</i>	
R38 *	Jumper to RJ when using 380V-50Hz incoming power. <i>Do not jumper to R41/46 or R40/44.</i>	
RJ *	Common for input power selection. Jumper to either R41/46, R40/44, or R38. <i>Do not jumper to more than one terminal at a time.</i>	
R20/22 *	Output power terminal. Supplies 1-phase 200V-50Hz or 1-phase 220V-60Hz @ 40VA maximum.	
R10/11 *	Output power terminal. Supplies 1-phase 100V-50Hz or 1-phase 110V-60Hz @ 40VA maximum.	
T10/11 T20/22 *	Output power return terminal for either 1-phase 200V-50Hz/220V-60Hz @ 40VA or 1-phase 100V-50Hz/110V-60Hz @ 40VA.	

* Supplied only on FLOWQSU models 4055 through 410K.

6.0 Operating Panel

6.1 Operating Panel Layout

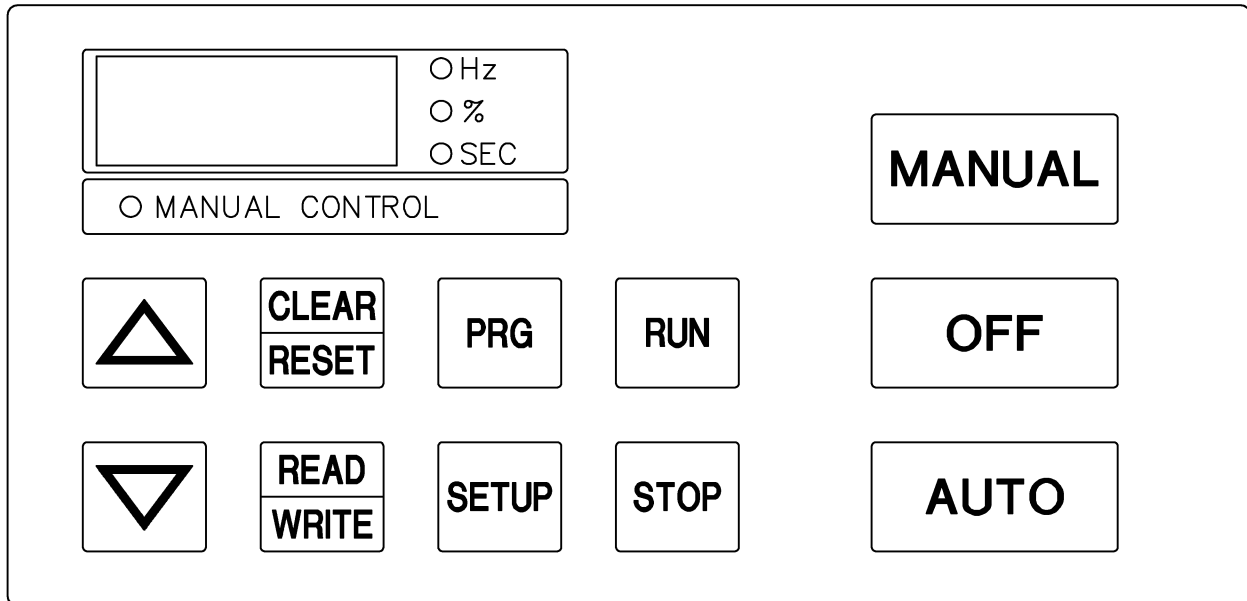

The operating panel enables the user to enable or disable the keypad, input commands from the keypad, and monitor the inverter operation on the LED displays. The panel consists of the keypad and LED displays. The illustration below shows the operating panel layout. See the following section for a description of each key and function. See page 6-3 for a functional description of the LED display.



6.2 Operating Panel Keys and Functions

The following chart explains each of the key functions on the keypad

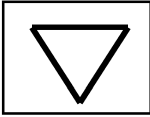
Keys and Functions

Key	Function
	Up scroll key used for increasing frequency or data values, scrolls parameter to parameter, or upwards scaling of remote meters (FM, AM).
	Down scroll key used for decreasing frequency or data values, scrolls parameter to parameter, or downwards scaling of remote meters (FM, AM).
	Used to start a normal forward/reverse run (only in manual mode), manual LED will flash in run mode even at frequency = 0 Hz.
	Key enables the manual control mode and allows commands to be entered from either the keypad or a computer terminal. The Manual control LED is on when operating in the manual control mode. When switching to auto mode, first press "off" key; otherwise inverter must be at 0 Hz. If "auto" key is pressed while still running in manual mode, an ":Err. 7" will flash.

6.2 Operating Panel Keys and Functions (cont'd)

Keys and Functions

OFF	Key disables RUN or STOP commands until either the AUTO or MANUAL key is pressed. Display reads "OFF". Motor coasts to a stop if key is pressed while motor is running
AUTO	Disables manual control and turns the manual control LED off; drive will accept commands from terminal strip connector or computer input only.
READ WRITE	This key is used to scroll through the system parameters (see page 7-2), read data from within the group or setup parameters, write data changes into the non-volatile memory. System status information is available while drive is running.
PRG	Key used to scroll through the parameter groups and returns to frequency setting if in any other mode.
CLEAR RESET	When data changes have been made in error, this key will allow user to clear data back to data = 0 (if allowed). Also resets trips, or returns to frequency mode.
STOP	This key stops the drive in manual mode. The manual mode stop can be programmed to coast or decelerate to a stop. Will cause the drive to trip and coast in any other mode. Can be used as an emergency stop in any mode.
SETUP	Allows access to setup parameters only and will automatically return to frequency mode after all parameters have been stepped through.

6.3 LED Display and Display Monitoring

The LED display provides the user with the operating frequency, function settings, and status information necessary to easily monitor and set the operating parameters. The individual LED's are identified and explained in the following chart.

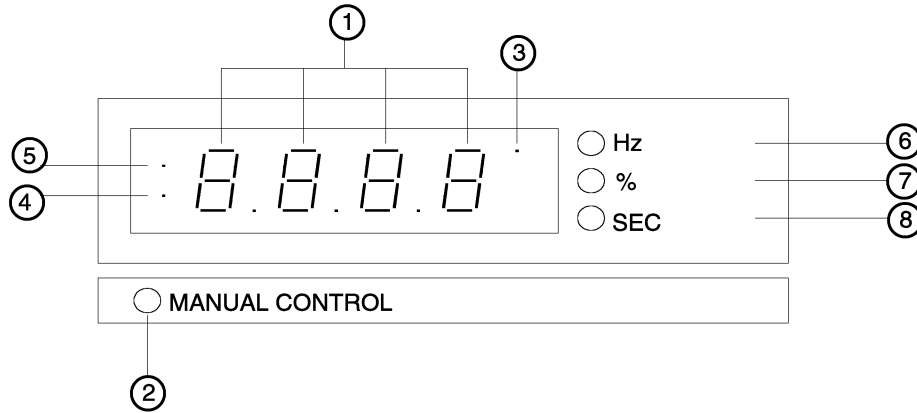

































Display Monitoring

Item	Name	Function/status
①	Monitor display	7-segment, 4-column LED Displays frequency, title, data, etc.
②	Panel control LED	ON when the unit is in the manual control mode OFF when the unit is in the auto (remote) control mode FLASHING when the unit is in the manual control mode and the motor is running
③	Option mode LED	ON when the computer interface option is enabled. (Contact Toshiba for information.)
④ ⑤	Monitor display	<input type="checkbox"/> Both LED's are normally OFF when the monitor is displaying operating frequency or scaled operating frequency from the display scaler. <input type="checkbox"/> <input checked="" type="checkbox"/> LED 5 is ON and LED 4 is OFF when unit is in a patterned run sequence. <input type="checkbox"/> <input checked="" type="checkbox"/> Both LED's are ON when the unit is in the parameter setting mode using the operating panel keypad and the motor is not running. <input checked="" type="checkbox"/> <input checked="" type="checkbox"/> Both LED's are FLASHING when the unit is in the parameter setting mode using the operating panel keypad and the motor is running. <input checked="" type="checkbox"/> <input checked="" type="checkbox"/> LED 4 is ON and LED 5 is OFF when the unit is in the parameter setting mode and the operating panel keypad is disabled. <input checked="" type="checkbox"/> (Computer Command Mode)
⑥	Hz display LED	ON when the display is indicating frequency.
⑦	% display LED	ON when the display is indicating a percentage.
⑧	Time display LED	ON when displaying time in seconds.

6.4 Display Alphanumerics

The 7 segment LED display is able to display all of the numerals but is unable to properly form all of the characters of the alphabet. Therefore some characters of the alphabet will appear as special symbols and others are not used at all. The tables below show the numbers and characters that are used and how each appears on the 7 segment display.

Numerics	LED display
0	
1	
2	
3	
4	
5	
6	
7	
8	
9	

Characters	LED display
A	
b	
C	
d	
E	
F	
G	
H	
I	
J	
L	
M	
n	
O	 or 
P	
r	
S	
t	
U	
v	
y	
-	

7.0 Parameter Groups

7.1 Definitions of Setup and Group Parameters

SETUP PARAMETERS

This parameter group is accessed by pressing the dedicated "SETUP" key on the keypad. This parameter group should not be considered operationally any different from other parameter groups. This group is assigned a dedicated key because of the probable need to access it most often and because it contains the adjustable parameters considered "fundamental" to drive operation and application. This includes parameters such as acceleration and deceleration times, upper and lower frequency limits, bias and gain, electronic thermal protection, and stall prevention activation.

USER GROUP PARAMETERS :U.PRG

This parameter group is accessible from the group parameter menu. The menu can be scrolled by repeated pressing of the "PRG" key. This group contains features such as assignment of a personal lockout code, options for the Volts per Hertz (V/F) ratios, reset to factory settings, limiting maximum frequency, setup of automatic torque boost and level, #2 acceleration and deceleration time and selection of patterns for #1 or #2.

COMMUNICATION GROUP PARAMETERS :C.PRG

This parameter group is accessible from the group parameter menu. The menu can be scrolled by repeated pressing of the "PRG" key. This group contains features for setting up the serial communication protocol, carrier frequency selection, input and output terminal selection, and setting up the unit for power failure control and automatic restarting.

JUMP FREQUENCY GROUP PARAMETERS :J.PRG

This parameter group is accessible from the group parameter menu. The menu can be scrolled by repeated pressing of the "PRG" key. This group contains features for setting three different operating patterns jump frequency and jump width. This group also contains selections for PID control and adjustments.

DISPLAY GROUP PARAMETERS :D.PRG

This parameter group is accessible from the group parameter menu. The menu can be scrolled by repeated pressing of the "PRG" key. This group contains features for setting up low speed frequency detection and speed reach selection. It also contains settings for DC braking.

SPEED GROUP PARAMETERS :S.PRG

This parameter group is accessible from the group parameter menu. The menu can be scrolled by repeated pressing of the "PRG" key. This group contains features for setting multispeed run frequencies 1 - 6 and firespeed override frequency.

PATTERN FREQUENCY GROUP PARAMETERS :P.PRG

This parameter group is accessible from the group parameter menu. The menu can be scrolled by repeated pressing of the "PRG" key. This group contains features for setting pattern 1 - 7 forward or reverse and run time, number of cycles, jog frequency, jog stop pattern selection, and setting of hysteresis.

In each of the above group parameters, some of the most important functions have been mentioned. The following System Parameters Adjustment Range and Factory Setting tables show all of the group parameters with each of the functions are shown in detail. The ITEM NO. is an identifier used for reference only. It shows the correct numerical order for each function. This is helpful when locating the function definition in Keypad Operating Functions (See Section 9.0 page 9-1).

7.2 System Parameters Adjustment Range and Factory Settings

PARAMETER DISPLAY	ITEM NO.	PARAMETER DESCRIPTION	ADJUSTMENT RANGE	FACTORY SETTING	REFERENCE PAGE
SETUP PARAMETERS *					
:ACC1	1	Acceleration time #1	0.1 - 1200 sec	90.0 sec	9-1
:DEC1	2	Deceleration time #1	0.1 - 1200 sec	120.0 sec	9-1
:UL	3	Upper frequency limit	0.0 Hz - FH	60.0 Hz	9-1
:LL	4	Lower frequency limit	0.0 Hz - UL	0.0 Hz	9-1
:P1	5	Terminal IV point #1 setting signal	0 - 100 %	20 %	9-1
:F-P1	6	Point #1 output frequency	0.0 Hz - FH	0.0 Hz	9-1
:P2	7	Terminal IV point #2 setting signal	0 - 100 %	100 %	9-1
:F-P2	8	Point #2 output frequency	0.0 Hz - FH	60.0 Hz	9-1
:THR	9	Electronic thermal protection level	10 - 100 %	100 %	9-1
:SEL	10	Stall prevention activation level	10 - 120 %	120 %	9-1
:SELY	11	Electronic thermal protection select	0: STD-motor, no soft stall 1: STD-motor, soft stall 2: VF-motor, no soft stall 3: VF-motor, soft stall	1	9-2
:U.PRG	USER GROUP PARAMETERS **				
:FH	1	Maximum frequency	30 - 160 Hz	60 Hz	9-3
:A.tb	2	Automatic torque boost	0: Off 1: On	0	9-3
:tb	3	Torque boost	0 - 30 %	3 %	9-3
:bFL	4	Base frequency of maximum voltage level	25 - 160 Hz	60 Hz	9-3
:LYP	5	Standard setting mode selection	0: Factory setting 1: 50 Hz motor 2: 60 Hz motor 3: Reset to factory setting	0	9-3
:ACC2	6	Acceleration time #2	0.1 - 1200 sec	10.0 sec	9-3
:DEC2	7	Deceleration time # 2	0.1 - 1200 sec	10.0 sec	9-3
:Pt.1	8	Pattern of ACC/DEC #1	0: Linear 1: S-curve 2: C-curve	0	9-3
:Pt.2	9	Pattern of ACC/DEC #2	0: Linear 1: S-Curve 2: C-Curve	1	9-4
:SEL2	10	Selection to use ACC/DEC #1 or #2	0: Acc/Dec #1 1: Acc/Dec #2	0	9-4
:Pt	11	V/F pattern	0: Constant torque 1: Variable torque	1	9-4
:ES.CS	12	Timed stop/coast to stop selection	0: Deceleration stop 1: Coast to stop	0	9-4
:Code	13	Personal lock out code	0 - 255	0	9-4

7.2 System Parameters Adjustment Range and Factory Settings (cont'd)

PARAMETER DISPLAY	ITEM NO.	PARAMETER DESCRIPTION	ADJUSTMENT RANGE	FACTORY SETTING	REFERENCE PAGE
:C.PRG	COMMUNICATION GROUP PARAMETERS **				
:RST	1	Automatic restart after instantaneous power failure selection	0: Off 1: On	1	9-5
:rty	2	Automatic reset selection	0: Off 1: On	1	9-5
:PFL	3	Power failure function selection <i>(This function valid on 230 volt units only)</i>	0: Off 1: On	0	9-6
:trCL	4	Fault trip data retention selection	0: Cleared 1: Saved	0	9-6
:1tb	5	Input terminal selection	0: SS2, SS3 1: JOG, SS3 2: SS2, AD2 3: JOG, AD2	0	9-6
:0tb	6	Output terminal selection	0: LL, UL 1: LOW, UL 2: LL, RCH 3: LOW, RCH	3	9-6
:OPT	7	Option card multi-functional selections	0: Off 1: 12 bit binary absolute input 2: 12 bit binary relativity input 3: 3 number BCD input 4: 3 number BCD input 5: Pulse frequency reference inout 6: Multi-speed input 7: Selection 1 with write signal 8: Selection 2 with write signal 9: Selection 3 with write signal 10: Selection 4 with write signal 11: Selection 5 with write signal 12: Selection 6 with write signal	0	9-6
:Ino.	8	Inverter number	0 - 31	0	9-6
:brAT	9	Baud rate (RS232/RS485)	0: 150/1200 1: 300/2400 2: 600/4800 3: 1200/9600 4: 2400/19200	0	9-6
:Cbit	10	Communication data bits	0: 7 bits 1: 8 bits	0	9-6
:StPr	11	Communication parity check and stop bit	0: Even 1: Even 2: N/A 3: N/A 4: Odd 5: Odd	0	9-6
:CF	12	PWM carrier frequency	5 - 8 kHz	8 kHz	9-6

TOSHIBA

7.2 System Parameters Adjustment Range and Factory Settings (cont'd)

PARAMETER DISPLAY	ITEM NO.	PARAMETER DESCRIPTION	ADJUSTMENT RANGE	FACTORY SETTING	REFERENCE PAGE
:J.Prg	JUMP FREQUENCY GROUP PARAMETERS **				
:FJ1	1	Jump frequency #1	0.0 Hz - FH	0.0 Hz	9-7
:bFJ1	2	Jump width #1	0.0 Hz - FH	0.0 Hz	9-7
:FJ2	3	Jump frequency #2	0.0 Hz - FH	0.0 Hz	9-7
:bFJ2	4	Jump width #2	0.0 Hz - FH	0.0 Hz	9-7
:FJ3	5	Jump frequency #3	0.0 Hz - FH	0.0 Hz	9-7
:bFJ3	6	Jump width #3	0.0 Hz - FH	0.0 Hz	9-7
:Fb.P1	7	PID setpoint control select	0: Off 1: On	0	9-7
:GP	8	Proportional gain	0 - 9999	1000	9-7
:GI	9	Integral gain	0 - 9999	500	9-7
:GR	10	Differential gain	0 - 255	0	9-7
:GFS	11	Lag time constant	0 - 255	255	9-7
:b.Prg	DISPLAY GROUP PARAMETERS **				
:dSP.2	1	Universal unit multiplication factor	0.00 - 200.0 (0.00 = OFF)	0.00	9-8
:LF	2	Low speed detection	0.0 Hz - FH	0.5 Hz	9-8
:rCH	3	Speed reach selection	0: Complete ACC/DEC 1: Frequency reach reference	1	9-8
:rrCH	4	Speed reach detection range	0.0 Hz - FH	2.5 Hz	9-8
:FrCH	5	Speed reach reference	0.0 Hz - FH	60.0 Hz	9-8
:dbF	6	DC injection voltage start frequency	0.0 Hz - 10.0 Hz	0.0 Hz	9-8
:dbL	7	DC injection voltage	0 - 20 %	0 %	9-8
:dbt	8	DC injection time	0.0 - 5.0 sec	0.0 sec	9-8
:P.0Ut	9	Output voltage regulation	0 - 100 %	100 %	9-8
:OP5.5	10	Overvoltage stall protection select	0: On 1: Off	0	9-8
:S.Prg	SPEED GROUP PARAMETERS **				
:E.CHG	1	AC line/inverter transfer signal	0: Off 1: On	0	9-9
:Sr1	2	Multispeed run frequency #1	LL - UL	0.0 Hz	9-9
:Sr2	3	Multispeed run frequency #2	LL - UL	0.0 Hz	9-9
:Sr3	4	Multispeed run frequency #3	LL - UL	0.0 Hz	9-9
:Sr4	5	Multispeed run frequency #4	LL - UL	0.0 Hz	9-9
:Sr5	6	Multispeed run frequency #5	LL - UL	0.0 Hz	9-9
:Sr6	7	Multispeed run frequency #6	LL - UL	0.0 Hz	9-9
:FSOF	8	Firespeed override frequency (Sr7)	LL - UL	0.0 Hz	9-9

7.2 System Parameters Adjustment Range and Factory Settings (cont'd)

PARAMETER DISPLAY	ITEM NO.	PARAMETER DESCRIPTION	ADJUSTMENT RANGE	FACTORY SETTING	REFERENCE PAGE
:P.PRG	PATTERN FREQUENCY GROUP PARAMETERS **				
:F.r.	1	Forward/Reverse rotation select	0: Reverse 1: Forward	1	9-10
:rr.CC	2	Priority of RR terminal input	0: IV terminal input "on" 1: RR terminal input "on"	0	9-10
:P.SEL	3	Mode for pattern run ***	0: Off 1: Terminal 2: Computer	0	9-10
:P.t.t	4	Time unit for pattern run time select ***	0: Seconds 1: Minutes	0	9-10
:P.t.n	5	Quantity of pattern run cycles ***	0 - 255	0	9-10
:P.t.1t	6	Pattern #1 run time ***	0 - 8000	0	9-10
:P.t.1	7	Pattern #1 drive characteristics ***	0: Fwd run #1 Acc/Dec 1: Fwd run #2 Acc/Dec 2: Rev run #1 Acc/Dec 3: Rev run #2 Acc/Dec	0	9-10
:P.t.2t	8	Pattern #2 run time ***	0 - 8000	0	9-10
:P.t.2	9	Pattern #2 drive characteristics ***	0: Fwd run #1 Acc/Dec 1: Fwd run #2 Acc/Dec 2: Rev run #1 Acc/Dec 3: Rev run #2 Acc/Dec	0	9-10
:P.t.3t	10	Pattern #3 run time ***	0 - 8000	0	9-10
:P.t.3	11	Pattern #3 drive characteristics ***	0: Fwd run #1 Acc/Dec 1: Fwd run #2 Acc/Dec 2: Rev run #1 Acc/Dec 3: Rev run #2 Acc/Dec	0	9-10
:P.t.4t	12	Pattern #4 run time ***	0 - 8000	0	9-10
:P.t.4	13	Pattern #4 drive characteristics ***	0: Fwd run #1 Acc/Dec 1: Fwd run #2 Acc/Dec 2: Rev run #1 Acc/Dec 3: Rev run #2 Acc/Dec	0	9-10
:P.t.5t	14	Pattern #5 run time ***	0 - 8000	0	9-10
:P.t.5	15	Pattern #5 drive characteristics ***	0: Fwd run #1 Acc/Dec 1: Fwd run #2 Acc/Dec 2: Rev run #1 Acc/Dec 3: Rev run #2 Acc/Dec	0	9-10
:P.t.6t	16	Pattern #6 run time ***	0 - 8000	0	9-11
:P.t.6	17	Pattern #6 drive characteristics ***	0: Fwd run #1 Acc/Dec 1: Fwd run #2 Acc/Dec 2: Rev run #1 Acc/Dec 3: Rev run #2 Acc/Dec	0	9-11
:P.t.7t	18	Pattern #7 run time ***	0 - 8000	0	9-11
:P.t.7	19	Pattern #7 drive characteristics ***	0: Fwd run #1 Acc/Dec 1: Fwd run #2 Acc/Dec 2: Rev run #1 Acc/Dec 3: Rev run #2 Acc/Dec	0	9-11

7.2 System Parameters Adjustment Range and Factory Settings (cont'd)

PARAMETER DISPLAY	ITEM NO.	PARAMETER DESCRIPTION	ADJUSTMENT RANGE	FACTORY SETTING	REFERENCE PAGE
:P.PRG	PATTERN FREQUENCY GROUP PARAMETERS (cont'd) **				
:JOG	20	Jog frequency	0.0 - 20.0 Hz	5.0 Hz	9-11
:J.STP	21	Jog stop select	0: Deceleration stop 1: Coast to stop 2: DC injection stop	0	9-11
:F-ST	22	Start-up frequency	0.0 - 10.0 Hz	0.0 Hz	9-11
:F.RUN	23	Run frequency	0.0 Hz - FH	0.0 Hz	9-11
:F.HYS	24	Run frequency hysteresis	0.0 Hz - FH	0.0 Hz	9-12

* Parameters are alternately exhibited from setup menu by alternately pressing **SETUP** key. Value of parameter can be read by pressing **READ/WRITE** key. Value can be changed by continued pressing of "up" or "down" key. When desired value is reached press the **READ/WRITE** key to store new value.

** Group parameters are exhibited from group parameter menu by pressing **PRG** key. When the desired group parameter is reached, individual parameters within the group can be exhibited by alternately pressing the "up" or "down" key. Value of exhibited parameter can be read by pressing **READ/WRITE** key. Value of exhibited parameter can be changed by continued pressing of "up" or "down" key. When desired value is reached press the **READ/WRITE** key to store new value.

*** When P.SEL (mode for pattern run) is set to 0; pattern run times (Pt.1t through Pt.7t) and pattern run selections (Pt.1 through Pt.7) will be skipped when scrolling through the Pattern Frequency Group Parameters.

8.0 System Status Monitoring

The inverter operates with varying levels of supply voltage and current. A variable output frequency of voltage and current is generated to drive the motor load. These input and output levels of operating voltage and current are continually monitored by the inverter. It also monitors for over temperature, input and output terminal settings, and condition of the microprocessor with associated memory elements. These operating settings and variables have a certain value or "status" associated with them and are used for inverter operation. They can also be monitored by the operator to show the setup and conditions existing at any time. Three types of status monitoring are used and explained below.

8.1 Normal Status Monitoring

Normal status monitoring occurs during normal operation. The ST-CC terminal must be closed to run. The following table shows applicable keys, display, and status conditions for normal status monitoring. The display values are for factory settings where no trips or errors occurred. The display will change only if a new value is programmed into the associated group adjustment range or if trips or errors have occurred. Scrolling occurs by repeatedly pressing the **READ/WRITE** key after output frequency is displayed. Trips or errors that have occurred (up to a total of three), will be displayed in order immediately after the keypad software version display.

Key	Display	Status Condition
OFF	:OFF	Inverter is in the off position when ":OFF" is flashing.
AUTO	0.0	Inverter is ready to run from terminal or computer interface.
MAN	0.0	Inverter is ready to run from keypad and manual control LED is on.
RUN	[Output Frequency]	Displays inverter's output frequency.
STOP	E	Emergency stop executed from keypad while in an automatic run or while in remote control mode when "E" is flashing.
RD/WRT	F or r	Indicates a forward (F) or reverse (r) run. If not running, the display refers to the direction the unit would run.
RD/WRT	:60.0	Displays the frequency which the inverter is set to output when running (60 Hz is factory setting).
RD/WRT	:C 0	Displays the percentage of the inverter's rated output current when running (displays "0" when not running).
RD/WRT	:P 3	Displays the percentage of the inverter's rated output voltage when running (displays "3" when not running).
RD/WRT	:1-40	Displays input terminal status code. See page 8-4
RD/WRT	:0-01	Displays output terminal status code. See page 8-5
RD/WRT	:u .5.3	Displays inverter's software version.
RD/WRT	:u.P5.0	Displays keypad's software version.
RD/WRT	:4<->:n.Err	Displays 4th error (no error occurred).
RD/WRT	[Output Frequency]	Returns to the original display of output frequency.

8.2 Automatic Status Monitoring

Automatic status monitoring displays abnormal status conditions that can occur during normal inverter operation. These conditions will cause warnings and error messages to be displayed but will not cause the inverter to trip. The table below shows these abnormal conditions and the associated display that will appear. These displays usually appear during the time that the abnormal condition is occurring and will go away when it is corrected. The abnormal condition should be corrected as soon as possible.

Key	Display	Status Condition
-----	St ↔ oPE n	ST-CC terminal connector is open (must be connected to run).
-----	P O F F	The main AC supply power is low.
-----	n O F F	The inverter's DC bus voltage is low.
-----	[[Output Frequency]	Stall prevention is activated when flashing "C" appears in front of output frequency.
-----	P [Output Frequency]	Overvoltage limitation is activated when flashing "P" appears in front of output frequency.
-----	L [Output Frequency]	Overload detection is activated when flashing "L" appears in front of output frequency.
-----	: ↔ Err.7	This error occurs while trying to switch from manual to automatic mode or automatic mode to manual while inverter is outputting a frequency.
-----	: ↔ Err.1	This is a frequency setting signal error. Points 1 and 2 of a frequency setting signal are to close together. Correct the setting of points 1 and 2 by providing an adequate distance between them.
-----	: ↔ Err.0	This error can be seen when attempting to set any of the parameters with incorrect data values.
-----	: ↔ Err.U	This error can be seen when attempting to set any of the parameters with incorrect data values.

8.3 Tripped Status Monitoring

Tripped status monitoring displays abnormal status conditions that can occur during normal inverter operation. The table below shows these abnormal conditions which will cause the inverter to trip "off" (stop normal operations). They are usually caused by excessive power dissipation in either the inverter or motor, or by other circuit abnormalities. A tripped status monitoring display usually appears during the time that the abnormal condition is occurring and then remains on the display after the inverter trips off. The inverter will remain off and the tripped status will remain displayed until the inverter is attended to (reset) by the operator. Most conditions, which cause the inverter to trip, occur very rapidly and the operator usually will not be aware that the trip conditions are in process until the inverter has stopped. Each of the trip statuses are automatically recorded in the non-volatile EEPROM memory of the inverter. An ordered semi-permanent record of each trip (up to four) is created and can be viewed during the normal status monitoring "scroll". These recorded trips are viewed immediately after the keypad's software version, in the order that they occurred, as the **READ/WRITE** key is pressed. These trips remain in the memory until replaced by new trips.

Key	Display	Status Condition
-----	OC1	* Overcurrent occurred during an acceleration.
-----	OC2	* Overcurrent occurred during a deceleration.
-----	OC3	* Overcurrent occurred during a run.
-----	OCR	Overcurrent detected at start-up (suspect inverter damage).
-----	OCL	Overcurrent detected at start-up (suspect load short circuit).
-----	OP2	* Overvoltage generated during deceleration.
-----	OP	* Overvoltage from power supply.
-----	OL	* Overload of motor occurred.
-----	OH	Overheat of inverter body or external fault occurred.
-----	EF	Ground fault overcurrent occurred in the load circuit.
-----	Err.2	Main RAM in main CPU is abnormal.
-----	Err.3	Main ROM in main CPU is abnormal.
-----	Err.4	RAM in operating panel CPU is abnormal.
-----	Err.5	ROM in operating panel CPU is abnormal.
-----	Err.6	Key in the operating panel keypad defective.
-----	EEP	EEPROM data abnormality.
-----	EEP2	EEPROM trip data abnormality.
-----	EEP3	EEPROM setting data abnormality.
-----	Err.t	Communication data link abnormality.

* These faults can be programmed to automatically restart

8.4 Input Terminal Status Code

The table below shows the status codes when contact closures are placed across the input terminals. JOG(SS2) and AD2(SS3) are multi-functional terminals. The correct terminal input representation is determined by setting the Input Selection function [:l.tb]. Refer to Item 5 on page 7-3 and Terminal Block details on page 5-5. A reading such as the example below indicates that terminal ST-CC has a closed contact across it. If input terminal select [:l.tb]=3 then terminal JOG(SS2)=JOG, terminal AD2(SS3)=AD2, and they are both open contact.

: 1 - 4 0

Display	RR-CC	ST-CC	F-CC	R-CC	Display	SS1-CC	JOG-CC (SS2)	AD2-CC (SS3)	RST-CC
0	OFF	OFF	OFF	OFF	0	OFF	OFF	OFF	OFF
1	OFF	OFF	OFF	ON	1	OFF	OFF	OFF	ON
2	OFF	OFF	ON	OFF	2	OFF	OFF	ON	OFF
3	OFF	OFF	ON	ON	3	OFF	OFF	ON	ON
4	OFF	ON	OFF	OFF	4	OFF	ON	OFF	OFF
5	OFF	ON	OFF	ON	5	OFF	ON	OFF	ON
6	OFF	ON	ON	OFF	6	OFF	ON	ON	OFF
7	OFF	ON	ON	ON	7	OFF	ON	ON	ON
8	ON	OFF	OFF	OFF	8	ON	OFF	OFF	OFF
9	ON	OFF	OFF	ON	9	ON	OFF	OFF	ON
A	ON	OFF	ON	OFF	A	ON	OFF	ON	OFF
b	ON	OFF	ON	ON	b	ON	OFF	ON	ON
c	ON	ON	OFF	OFF	c	ON	ON	OFF	OFF
d	ON	ON	OFF	ON	d	ON	ON	OFF	ON
E	ON	ON	ON	OFF	E	ON	ON	ON	OFF
F	ON	ON	ON	ON	F	ON	ON	ON	ON

ON: Implies a closed contact or short between terminals.
 OFF: Implies an open contact or no connection between terminals.

Terminal

Connections Inverter's Status when terminal connections are closed (ON).
 RR-CC (See reference signal terminal connections on page 5-6).
 ST-CC RUN ENABLED (**Must be connected to run**)
 F-CC FORWARD RUN ENABLED
 R-CC REVERSE RUN ENABLED

If both F-CC and R-CC are on then a REVERSE RUN IS ENABLED.

SS1-CC MULTI-SPEED RUN ENABLED
 SS2-CC MULTI-SPEED RUN OR JOG RUN ENABLED (Dependent upon SS2's usage)
 SS3-CC MULTI-SPEED RUN OR ACC/DEC 2 ENABLED (Dependent upon SS3's usage)
 RST-CC RESET MODE ENABLED (Reset occurs after momentary contact closure)

8.5 Output Terminal Status Code

The table below shows the status codes of the open collector transistor outputs. RCH(UL) and LOW(LL) are multi-functional terminals. The correct terminal output representation is determined by setting the Output Selection function [:0.tb]. Refer to Item 6 on page 7-3 and Terminal Block details on page 5-5. If output terminal select [:0.tb]=2 then terminal RCH(UL)=RCH and terminal LOW(LL)=LL. A reading such as the example below indicates that terminals RCH and LL are "on" (collector shorted to ground).

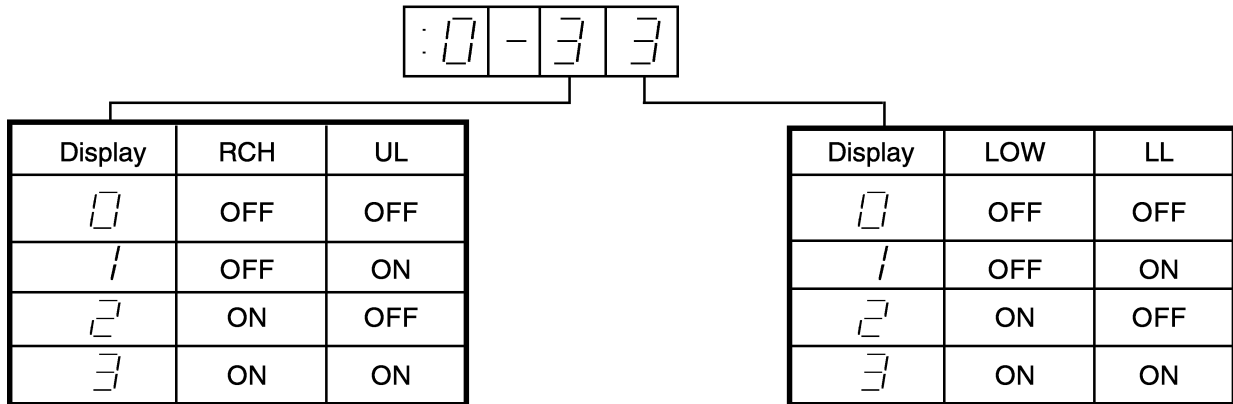

- RCH: Output frequency is within the set reach frequency range or acc/dec is complete.
- LOW: Output frequency is equal to or greater than low speed frequency.
- UL: Output frequency has reached the upper limit frequency (UL).
- LL: Output frequency is equal to or greater than the lower limit frequency (LL).

9.0 Keypad Operating Functions

This section discusses keypad operating functions. All of the functions that can be accessed through the keypad, are discussed. The functions are listed and discussed in the order in which they are accessed. The item number identifier following the function is used for ease of location in the System Parameters Adjustment Range and Factory Settings (see section 7.2).

9.1 SETUP PARAMETERS

ACCELERATION TIME #1 (ITEM 1) - Sets the time required to accelerate from 0Hz to the maximum frequency (FH) set by function [:FH]. **Setting this time to low can cause undue stress and over current tripping of the drive.**

DECELERATION TIME #1 (ITEM 2) - Sets the time required to decelerate from maximum frequency (FH) to 0Hz. **Setting this time to low can cause undue stress and over voltage tripping of the drive.**

UPPER FREQUENCY LIMIT (ITEM 3) - Sets the upper frequency limit of applications. The inverters frequency can be increased up to this upper limit and cannot be increased any further. **The value of the maximum safe frequency (FH) must be equal to or greater than the upper frequency limit.**

LOWER FREQUENCY LIMIT (ITEM 4) - Sets the lower frequency limit of applications. The inverters frequency can be decreased down to this lower limit and cannot be decreased any further without stopping or resetting the lower limit.

TERMINAL IV REFERENCE POINT # 1 (ITEM 5) - Sets the percentage of the input signal on terminal IV which is used to reference the # 1 output frequency (P1) designated by function [F-P1]

POINT # 1 OUTPUT FREQUENCY (ITEM 6) - Sets the output frequency used for reference point function [FP-1].

TERMINAL IV REFERENCE POINT # 2 (ITEM 7)- Sets the percentage of the input signal on terminal IV which is used to reference the # 2 output frequency designated by function [F-P2]

POINT # 2 OUTPUT FREQUENCY (ITEM 8) - Sets the output frequency used for reference point [FP-2].

ELECTRONIC THERMAL PROTECTION LEVEL (ITEM 9) - Sets the thermal overload detection level to match the ratings and characteristics of the motor being used (10 to 100% of rated output current). **The inverter can run at 110% continuously and may cause unnecessary motor overheating unless this compensation is used.**

STALL PREVENTION ACTIVATION LEVEL (ITEM 10) - Sets the activation level of the stall protection function (90 to 120% of rated output current). When the stall level is reached the inverter begins a soft stall procedure by lowering the frequency and voltage to prevent overcurrent tripping. Once the soft stall procedure starts the output current will be clocked. If output current is not reduced within a specified time a fault will occur. The soft stall function is particularly useful in situations where load current decreases as the revolution speed decreases (fan and pump equipment). This function is activated through the Electronic Thermal Protection Select (:SEL4). **Instantaneous trip current limits are factory set and are dependent upon inverter size as well as the motor ripple current.**

9.1 SETUP PARAMETERS (cont'd)

ELECTRONIC THERMAL PROTECTION SELECT (ITEM 11) - Select standard motor or Vf motor with or without soft stall as shown in the following overload detection curves.

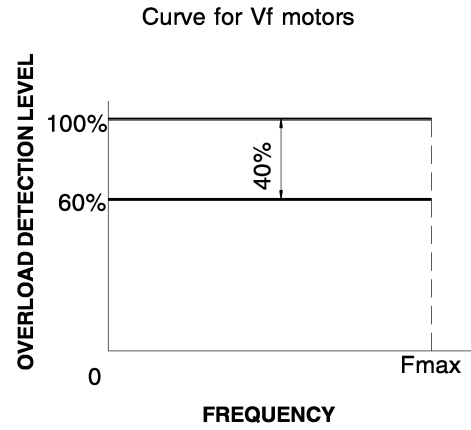
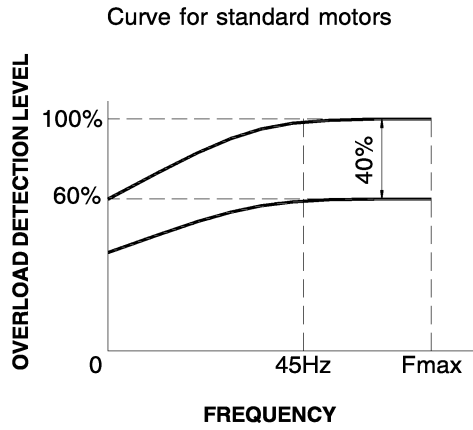

9.2 USER GROUP PARAMETERS

MAXIMUM FREQUENCY (ITEM 1) - This parameter sets the output frequency to a maximum value. It is very important that this factory setting not be changed without first checking the maximum operating speed of the motor and load equipment.

Overspeeding of the motor can cause serious damage to the motor and/or the driven load equipment.

AUTOMATIC TORQUE BOOST (ITEM 2) - Automatically increases the percentage of voltage boost when starting torque requirements are abnormally high.

TORQUE BOOST (ITEM 3) - Increases the voltage (voltage boost) to the motor for increased starting torque.

BASE FREQUENCY OF MAXIMUM VOLTAGE LEVEL (ITEM 4) - Sets the base operating frequency at which the output voltage is 100%.

STANDARD SETTING MODE SELECTION (ITEM 5) - This parameter automatically enters the optimum settings for operating either a 50Hz or 60Hz motor or factory default settings. ***A reset to factory settings can be made from this parameter.***

ACCELERATION TIME #2 (ITEM 6) - Sets an alternate time required to accelerate from 0Hz to the maximum frequency (FH). Use function [SEL2] to select either acceleration time #1 or #2. ***Setting this time to low can cause undue stress and over current tripping of the drive.***

DECELERATION TIME #2 (ITEM 7) - Sets the time required to decelerate from maximum safe frequency (FH) to 0Hz. Use function [SEL2] to select either deceleration time #1 or #2. ***Setting this time to low can cause undue stress and over voltage tripping of the drive.***

PATTERN OF ACC/DEC #1 (ITEM 8) - Select one of three output frequency patterns. These patterns are shown in the pattern curves below. Use function [SEL2] to select either acc/dec pattern #1 or #2.

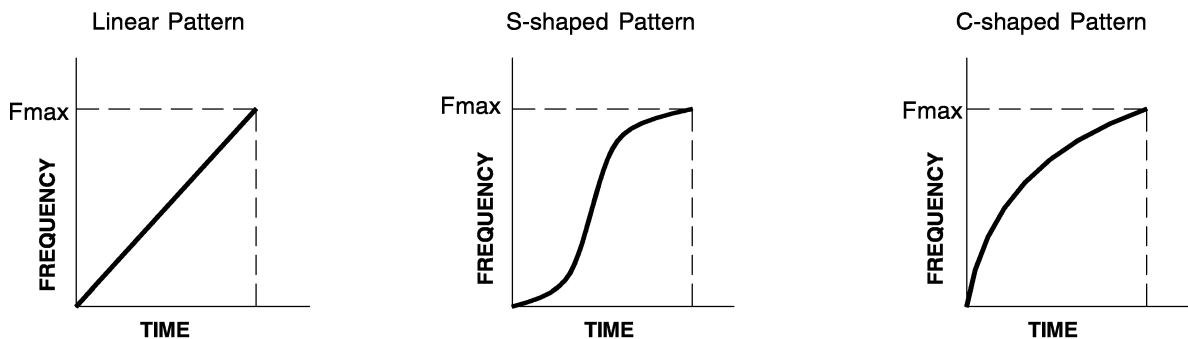

The Linear pattern accelerates linearly.

The S-shaped pattern gradually accelerates a motor in a range where the motor provides a low torque. This is particularly suited for material handling machinery.

The C-shaped pattern quickly accelerates a motor in a range where the motor provides a low torque. This is well suited for a high speed run.

9.2 USER GROUP PARAMETERS (cont'd)

PATTERN OF ACC/DEC #2 (ITEM 9) - Select as an alternate one of the three output frequency patterns. These patterns are the same as those for acc/dec pattern #1 and are shown in the pattern curves from the previous page. Use function [SEL2] to select either acc/dec pattern #1 or #2.

SELECTION TO USE ACC/DEC #1 OR #2 (ITEM 10) - Use this function to select either acc/dec #1 or acc/dec #2.

V/F PATTERN (ITEM 11) - Use this function to select either constant or variable torque. The V/f characteristic may be set for constant torque loads, resulting in a linear relationship between output voltage and frequency. The setting for variable torque loads sometimes results in energy savings and lower motor noise, if the application is suitable. Fans and centrifugal pumps are the most common types of loads associated with the variable torque load V/f pattern.

V/f Curve for constant torque

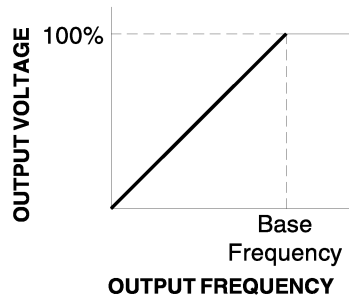

V/f Curve for variable torque

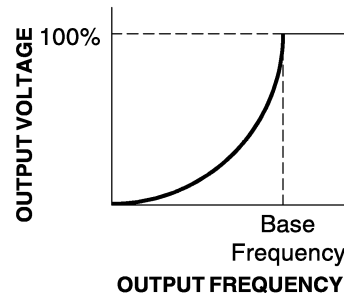

TIMED STOP/COAST TO STOP SELECTION (ITEM 12) - Use this function to select either a timed deceleration to a stop or a power off coast to a stop.

PERSONAL LOCK OUT CODE (ITEM 13) - Use this function to establish a security entry code for programming the inverter functions. This function locks out access to the PRG and SETUP parameters. **Removal of power does not remove the security lock feature. Remember the code.**

9.3 COMMUNICATION GROUP PARAMETERS

AUTOMATIC RESTART AFTER INSTANTANEOUS POWER FAILURE SELECTION (ITEM 1) - Use this function to select auto-restart on or off. When selected, the inverter will automatically restart into a free-rotating motor. This restart will occur only after an instantaneous power interruption has occurred. The function allows the inverter to sample the speed of the free-rotating motor at the end of the interruption and output a matching frequency when power is reapplied. This assures smooth restarts of a free-running motor when an instantaneous power loss has occurred such as when the system is switched from a commercial bypass run to an inverter run.

AUTOMATIC RESET SELECTION (ITEM 2) - When this function is selected, the inverter will automatically try to reset itself and restart the motor when a protective function activates fault trip. The following chart shows the auto-reset procedure for over-current and over-voltage fault trips.

AUTO RESET CONDITIONS

Cause of fault	Reset Process	Reset Failure Conditions
Overcurrent Overload	Tries to restart 5 times in succession 1st restart: 1 sec. after problem occurs. 2nd restart: 2 sec. after 1st restart. 3rd restart: 4 sec. after 2nd restart . 4th restart: 8 sec. after 3rd restart. 5th restart: 16 sec. after 4th restart.	The reset process follows this chart unless a fault, other than those listed, occurs. If this happens the inverter will not try to reset.
Overvoltage	Trips, displays OP, sets fault relay until overvoltage condition is removed. Fault relay will be cleared after reset.	

If the inverter is able to reach the original operating speed where the trip occurred, while trying to restart, then the reset process counter resets to zero. The process now begins again from 1st restart even if the original overcurrent condition still exists. While preparing for a reset, the auto-reset function causes the fault code "0.0" to be displayed alternately on the monitor display. Fault detection signals are not output during the reset process. If the cause of the failure has not been corrected, then the intervals before each attempted reset will be prolonged (See above chart). ***If the load exhibits an extremely large amount of inertia, automatic restart using the above procedure may not work.***

No restart is tried when any of the following messages are displayed:

- "OCA" Overcurrent (transistor short-circuit at start-up)
- "OCL" Overcurrent (load end short-circuit at startup)
- "EF" Ground fault
- "E" Emergency stop
- "EEP" EEPROM failure



CAUTION

Before using the automatic reset function, check to be certain that the auto-reset procedure will not damage or otherwise cause problems for the load equipment when the restart operations are being executed.

9.3 COMMUNICATION GROUP PARAMETERS (cont'd)

POWER FAILURE FUNCTION SELECTION (ITEM 3) - When this function is selected, the inverter will use the regenerative energy of a running motor to extend the power off ride through capability during momentary power dropouts (approximately 100mS). There are some cases when continuous operation is not possible due to the machines's inertia or load status, so this feature should be used in combination with the retry function.

This function is valid only on the 230 volt units.

FAULT TRIP DATA RETENTION SELECTION (ITEM 4) - This function can be set to store trip data in the EEPROM. The trip status data stored in this manner is available for observation while occurring or anytime after the drive has tripped. If the trip data is stored in this manner then the drive can only be started by manually resetting the drive [:typ]=3. See Tripped Status Monitoring Page 8-3.

INPUT TERMINAL SELECTION (ITEM 5) - Use this parameter to configure the inverter to recognize functional combinations of terminal inputs SS2, SS3, JOG, and AD2. See Input Terminal Operation Chart on page 10-1. This chart shows all of the combinations and the way that operating frequency can be selected by shorts or opens across these terminal inputs.

OUTPUT TERMINAL SELECTION (ITEM 6) - Use this parameter to configure the inverter for output functional combinations of terminals LL, UL, LOW, and RCH. See Output Terminal Operation Chart on page 10-1. This chart shows output configurations that can be assigned to these terminals.

OPTION CARD MULTI-FUNCTIONAL SELECTIONS (ITEM 7) - Use this function to select various configurations for the optional "Multi-function Printed Circuit Board".

This is used only when the "Multi-Functional Option Board" is installed.

INVERTER NUMBER (ITEM 8) - Use this function to select a number between 0 and 31 to assign the inverter. This will electronically "tag" the inverter when operating on a serial bus with other inverters. ***This is used only when the "Multi-Functional Option Board" is installed.***

BAUD RATE (ITEM 9) - Use this function to select the serial communication bit transfer rate. ***This is used only when the "Multi-Functional Option Board" is installed.***

COMMUNICATION DATA BITS (ITEM 10) - Use this function to select the serial communication bit word length in the communication protocol. ***This is used only when the "Multi-Functional Option Board" is installed.***

COMMUNICATION PARITY CHECK AND STOP BIT (ITEM 11) - Use this function to select the serial communication protocol. ***This is used only when the "Multi-Functional Option Board" is installed.***

PWM CARRIER FREQUENCY (ITEM 12) - Use this function to select the pulse width modulated carrier frequency. The acoustic noise of the motor changes when the PWM carrier frequency is changed. Changing the carrier frequency is usually effective in quieting the mechanical vibration noise caused when a resonance occurs at the load machine fan cover. Other system characteristics are also affected by the carrier frequency. Higher carrier frequencies cause additional heating of the inverter because of faster transistor switching speeds. ***Overheating of the inverter may become a problem at higher carrier frequencies and extremely heavy loads. Consult factory before changing.***

9.4 JUMP FREQUENCY GROUP PARAMETERS

JUMP FREQUENCY #1 (ITEM 1) - Use this function to set the beginning point of a frequency bandwidth to be skipped when running a motor. This function is to be used in conjunction with the bandwidth which is set by Jump Width #1. This function is to be used when a certain frequency is to be avoided, such as the resonance frequency of a loaded machine. Frequency jump does not engage when either accelerating or decelerating through the programmed frequencies and bandwidths. It does prevent a frequency setting from running continuously in one of the bandwidths assigned to be locked out by this procedure.

JUMP WIDTH #1 (ITEM 2) - Use this function to set the bandwidth for Jump Frequency #1.

JUMP FREQUENCY #2 (ITEM 3) - Use this function to set the beginning point of a second frequency bandwidth to be skipped when running a motor. This function is to be used in conjunction with the bandwidth which is set by Jump Width #2. This function should be used when a second resonant frequency should be avoided.

JUMP WIDTH #2 (ITEM 4) - Use this function to set the bandwidth for Jump Frequency #2.

JUMP FREQUENCY #3 (ITEM 5) - Use this function to set the beginning point of a third frequency bandwidth to be skipped when running a motor. This function is to be used in conjunction with the bandwidth which is set by Jump Width #3. This function should be used when a third resonant frequency should be avoided.

JUMP WIDTH #3 (ITEM 6) - Use this function to set the bandwidth for Jump Frequency #3.

PID SETPOINT CONTROL SELECT (ITEM 7) - Use this function to select proportional, integral, or differential gain (PID) either "on" or "off". This function is to be used in conjunction with the following functions of Proportional Gain, Differential Gain, and Integral Gain.

PROPORTIONAL GAIN (ITEM 8) - Use this function to set the gain of the PID control input signal.

INTEGRAL GAIN (ITEM 9) - Use this function to adjust the period of integration when comparing the set point to the feedback signal.

DIFFERENTIAL GAIN (ITEM 10) - Use this function to adjust the differential gain and stabilize the system when "hunting" occurs.

LAG TIME CONSTANT (ITEM 11) - Use this function to adjust the time of response when a change in the feedback signal occurs.

9.5 DISPLAY GROUP PARAMETERS

UNIVERSAL UNIT MULTIPLICATION FACTOR (ITEM 1) - The LED display can be changed to display values other than Hz. Revolution and linear speed such as RPM can be displayed. Use this function as a multiplication or division (fractional multiplication) scaler to convert to other units.

LOW SPEED DETECTION (ITEM 2) - Use this function to setup a low speed signal output. This function allows the drive to signal when the output frequency is greater than or equal to the selected "low speed frequency". The LOW(LL) terminal (see control/driver terminal block details on page 5-5) is normally the high impedance state of an open collector transistor. This terminal will go low (ground) when the low speed detection frequency is reached.

SPEED REACH SELECTION (ITEM 3) - Selects the option to output a signal when an acc/dec is complete or when the output frequency is within a selected range. The RCH(UL) terminal (see control/driver terminal block details on page 5-5) is normally the high impedance state of an open collector transistor. This terminal will go low (ground) when the speed reach detection frequency is reached. ***If a frequency range is selected then "Speed Reach Detection Range" and "Speed Reach Reference" functions should also be set.***

SPEED REACH DETECTION RANGE (ITEM 4) - Use this function to specify a range of frequencies, above and below the speed reach reference frequency. When the output frequency is within this range terminal RCH(UL) will be "on". See functions "Speed Reach Selection" and "Speed Reach Reference".

SPEED REACH REFERENCE (ITEM 5) - Use this function to set the speed reach detection frequency in the center of the speed reach detection range. See functions "Speed Reach Selection" and "Speed Reach Detection Range".

DC INJECTION VOLTAGE START FREQUENCY (ITEM 6) - Use this function to set the frequency at which DC injection voltage will begin to be applied to a motor during a decelerating stop. This function is used for precise positioning (inching) of the motor driven equipment. Use this function in conjunction with functions "DC Injection Voltage" and "DC Injection Time".

DC INJECTION VOLTAGE (ITEM 7) - Use this function to specify the percentage of total DC injection to apply during the injection time. Use this function in conjunction with functions "DC Injection Voltage Start Frequency" and "DC Injection Time".

DC INJECTION TIME (ITEM 8) - Use this function to specify the length of time that the DC injection voltage is to be applied. Use this function in conjunction with functions "DC Injection Voltage" and "DC Injection Voltage Start Frequency".

OUTPUT VOLTAGE REGULATION (ITEM 9) - This function allows the V/f characteristics to be set for a motor with a lower rated voltage by setting the V/f characteristics for 100% output voltage and then proportionally reducing the output voltage to the required level. An output voltage greater than the input voltage is not possible but the output voltage can be reduced proportionally to the input voltage.

OVERVOLTAGE STALL PROTECTION SELECT (ITEM 10) - Use this function to select an automatic lengthening of the deceleration time. ***Large inertia loads and/or rapid deceleration can create motor regeneration overvoltage on the DC bus. This condition can cause a trip and use of this function should be considered.***

9.6 SPEED GROUP PARAMETERS

AC LINE/INVERTER TRANSFER SIGNAL (ITEM 1) - Use this function to setup the inverter to allow a motor load to be transferred between the inverter and the AC line power by a signal to the inverter. ***This is used only when the "Multi-Functional Option Board is installed.***

MULTISPEED RUN FREQUENCY #1 (ITEM 2) - Use this function to set up 1st of 7 preset speed frequencies SR1. ***This frequency is run by input terminal connections.*** See Input Terminal Operations Page 10-1.

MULTISPEED RUN FREQUENCY #2 (ITEM 3) - Use this function to set up 2nd of 7 preset speed frequencies SR2. ***This frequency is run by input terminal connections.*** See Input Terminal Operations Page 10-1.

MULTISPEED RUN FREQUENCY #3 (ITEM 4) - Use this function to set up 3rd of 7 preset speed frequencies SR3. ***This frequency is run by input terminal connections.*** See Input Terminal Operations Page 10-1.

MULTISPEED RUN FREQUENCY #4 (ITEM 5) - Use this function to set up 4th of 7 preset speed frequencies SR4. ***This frequency is run by input terminal connections.*** See Input Terminal Operations Page 10-1.

MULTISPEED RUN FREQUENCY #5 (ITEM 6) - Use this function to set up 5th of 7 preset speed frequencies SR5. ***This frequency is run by input terminal connections.*** See Input Terminal Operations Page 10-1.

MULTISPEED RUN FREQUENCY #6 (ITEM 7) - Use this function to set up 6th of 7 preset speed frequencies SR6. ***This frequency is run by input terminal connections.*** See Input Terminal Operations Page 10-1.

FIRE SPEED OVERRIDE FREQUENCY (ITEM 8) - Use this function to set up 7th of 7 preset speed frequencies SR7. ***This frequency is run by input terminal connections.*** See Input Terminal Operations Page 10-1.

9.7 PATTERN FREQUENCY GROUP PARAMETERS

FORWARD/REVERSE ROTATION SELECT (ITEM 1) - Use this function to select between a forward or reverse motor rotation.

PRIORITY OF RR TERMINAL INPUT (ITEM 2) - Use this function to activate the terminal, either IV or RR, into which the analog reference signal will be input.

MODE FOR PATTERN RUN (ITEM 3) - Use this function to select where the start command will come from.

TIME UNIT FOR PATTERN RUN TIME SELECT (ITEM 4) - Use this function to select the time units to be used in the pattern run.

QUANTITY OF PATTERN RUN CYCLES (ITEM 5) - Use this function to setup the number of times that a pattern run is to be repeated.

PATTERN #1 RUN TIME (ITEM 6) - Use this function to set the run time of the preset speed frequency SR1.

PATTERN #1 DRIVE CHARACTERISTIC (ITEM 7) - Use this function to select the type of run for preset speed frequency #1. The selection can be a forward or reverse run, using either ACC/DEC #1 or ACC/DEC #2.

PATTERN #2 RUN TIME (ITEM 8) - Use this function to set the run time of the preset speed frequency SR2.

PATTERN #2 DRIVE CHARACTERISTIC (ITEM 9) - Use this function to select the type of run for preset speed frequency #2. The selection can be a forward or reverse run, using either ACC/DEC #1 or ACC/DEC #2.

PATTERN #3 RUN TIME (ITEM 10) - Use this function to set the run time of the preset speed frequency SR3.

PATTERN #3 DRIVE CHARACTERISTIC (ITEM 11) - Use this function to select the type of run for preset speed frequency #3. The selection can be a forward or reverse run, using either ACC/DEC #1 or ACC/DEC #2.

PATTERN #4 RUN TIME (ITEM 12) - Use this function to set the run time of the preset speed frequency SR4.

PATTERN #4 DRIVE CHARACTERISTIC (ITEM 13) - Use this function to select the type of run for preset speed frequency #4. The selection can be a forward or reverse run, using either ACC/DEC #1 or ACC/DEC #2.

PATTERN #5 RUN TIME (ITEM 14) - Use this function to set the run time of the preset speed frequency SR5.

PATTERN #5 DRIVE CHARACTERISTIC (ITEM 15) - Use this function to select the type of run for preset speed frequency #5. The selection can be a forward or reverse run, using either ACC/DEC #1 or ACC/DEC #2.

9.7 PATTERN FREQUENCY GROUP PARAMETERS (cont'd)

PATTERN #6 RUN TIME (ITEM 16) - Use this function to set the run time of the preset speed frequency SR6.

PATTERN #6 DRIVE CHARACTERISTIC (ITEM 17) - Use this function to select the type of run for preset speed frequency #SR6. The selection can be a forward or reverse run, using either ACC/DEC #1 or ACC/DEC #2.

PATTERN #7 RUN TIME (ITEM 18) - Use this function to set the run time of the preset speed frequency SR7 (Firespeed Override Frequency).

PATTERN #7 DRIVE CHARACTERISTIC (ITEM 19) - Use this function to select the type of run for preset speed frequency #SR7 (Firespeed Override Frequency). The selection can be a forward or reverse run, using either ACC/DEC #1 or ACC/DEC #2.

JOG FREQUENCY (ITEM 20) - Use this function to set the frequency at which the inverter will operate while in the jog mode. Used for moving in small increments when precise positioning of motor driven equipment is required.

JOG STOP SELECT (ITEM 21) - Use this function to select between three methods of stopping during a jog run.

START-UP FREQUENCY (ITEM 22) - Use this function to set the frequency at which the inverter will begin operating. In the manual control mode the frequency display will change as the "up" and "down" keys are pressed. However, an actual output does not occur until the start-up frequency is reached. In the terminal input mode the display will remain at zero until the start-up frequency is reached. This function along with the voltage boost function, allows the user to obtain an optimum boost level. See the illustrations below.

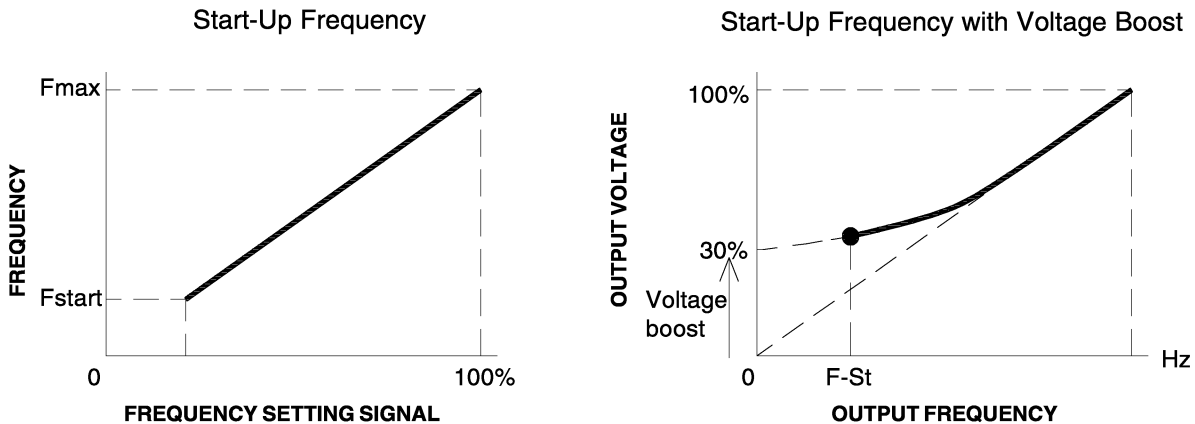

RUN FREQUENCY (ITEM 23) - Use this function to select a frequency to initiate inverter run/stop control.

9.7 PATTERN FREQUENCY GROUP PARAMETERS (cont'd)

RUN FREQUENCY HYSTERESIS (ITEM 24) - Use this function to offset the inverter run frequency. When the frequency reference signal reaches the $F_{run} + F_{phys}$ point, the drive will ramp the motor to that speed. The inverter will continue to follow the reference signal until it falls below the $F_{run} - F_{phys}$ at which time the drive will ramp the motor to a stop. See the illustration below.

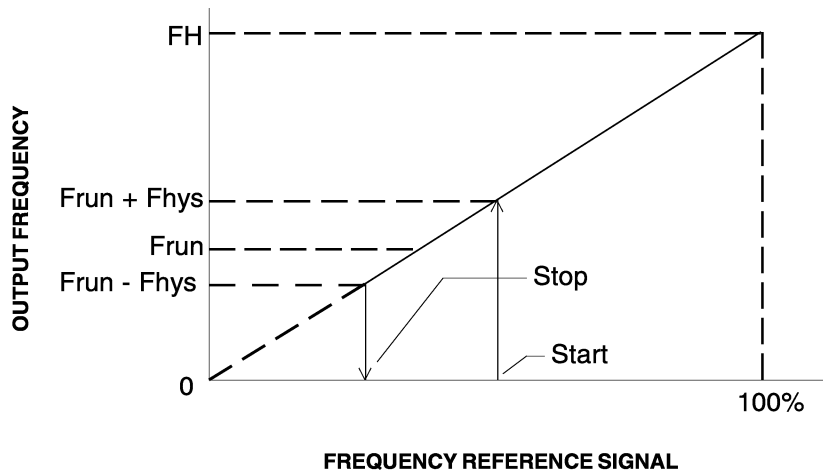

10.0 Input Terminal Operating Functions

Terminal operations are described as those operational features that can be controlled by opening or closing relays (switches) across the terminal block (see Control/Driver Board Terminal Block Details page 5-5). All of the functional combinations which can be accessed by terminal control are discussed in this section. Remote operations from the terminals are possible even if the inverter is in the manual control mode, however many of the terminals are multi-functional (used for more than one function) and must be programmed for a particular application. Also some of the terminals can be program disabled. Many of the operations that can be performed by this inverter require program configuration and use of the terminals. Some of these functions include Jog, Remote preset speeds, Remote meters, Outputting limit signals, and remote start/stop.

10.1 Input Terminal Selection Function

The following chart shows all of the functional combinations for input terminal selection function [l.tb]. See ITEM 5 page 7-3.

Input terminal selection parameter :1.tb	Terminal Connection			Selected operating frequency
	AD2/SS3-CC	JOG/SS2-CC	SS1-CC	
0: SS2, SS3	OFF OFF OFF OFF ON ON ON ON	OFF OFF ON ON OFF OFF ON ON	OFF ON OFF ON OFF ON OFF ON	Operating frequency set via PP, IV, RR terminals 1st speed operating frequency 2nd speed operating frequency 3rd speed operating frequency 4th speed operating frequency 5th speed operating frequency 6th speed operating frequency 7th speed operating frequency
1: JOG, SS3	OFF OFF OFF ON ON	OFF ON OFF OFF OFF	OFF OFF ON OFF ON	Operating frequency set via PP, IV, RR terminals Jogging run operating frequency 1st speed operating frequency 2nd speed operating frequency 3rd speed operating frequency
2: SS2, AD2	ON/OFF ON/OFF ON/OFF ON/OFF	OFF OFF ON ON	OFF ON OFF ON	Operating frequency set via PP, IV, RR terminals 1st speed operating frequency 2nd speed operating frequency 3rd speed operating frequency
3: JOG, AD2	ON/OFF ON/OFF ON/OFF	OFF ON OFF	OFF OFF ON	Operating frequency set via PP, IV, RR terminals Jogging run operating frequency 1st speed operating frequency

Note: When function [l.tb] is set to 2 or 3 the [AD2] function is activated. This function enables the user to remotely switch between the ACC/DEC patterns 1 and 2, provided [SEL2]=0. If [SEL2]=1 then the only pattern available is given by [ACC2], [DEC2], or [Pt.2]. With AD2-CC terminals shorted (ON) all ACC/DEC patterns are run using the settings of the [ACC2], [DEC2], or [Pt.2] parameters.

10.2 Starting/Stopping-Remote Control

The remote STARTING/STOPPING possibilities are identified in the following figure and table.

START/STOP Terminals Connections
(see terminal block detail section 5.6)

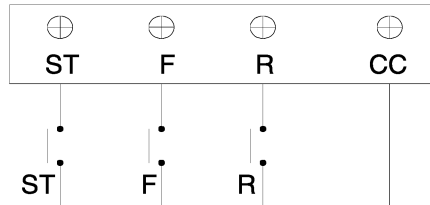

Remote START/STOP Connections Possibilities

Terminal Connection			Action
ST-CC	F-CC	R-CC	
OFF	ON/OFF	ON/OFF	The inverter is OFF. OFF will be displayed. If running when ST-CC is broken the motor will coast to a stop.
ON	OFF	OFF	The inverter is ON but not running.
ON	ON	OFF	The inverter is ON and will run in a FORWARD direction if an input signal is applied.
ON	OFF	ON	The inverter is ON and will run in a REVERSE direction if an input signal is applied.
ON	ON	ON	Same as REVERSE connection above.

* ON = dry contact closure, OFF = dry contact opening

Notes:

- 1) With ST-CC (ON), switching F-CC or R-CC (OFF) will cause the motor to decelerate to a stop.
- 2) If input power is turned off (with MCCB) while inverter is running, the motor will coast to a stop.
Avoid using the input power switch to start and stop the motor use for an emergency stop only.
- 3) Acceleration and Deceleration rates are determined by the preset values of function [:ACC1], [:ACC2] and [:DEC1], [:DEC2].
- 4) When switching from a forward run to a reverse run the motor will decelerate to a stop then accelerate in the reverse direction.

10.3 Remote control Frequency Setting

The drive can be run at various frequencies by use of external analog voltage and current control signals applied to terminals IV and RR. The keypad is not used for this operation other than assignment of values and programming instructions. It may be desirable from a security standpoint to disable the touchpad, when programming is completed, so that customer parameters and programming cannot be changed or revised. Use function [:RR.cc] item 2 on page 7-5 to set the terminals. **When the IV input is selected, an auto-mode is in effect so that voltage sensing terminal RR will override current sensing terminal IV if a voltage is applied to terminal RR.** See Terminal/Jumper Connections for Input Reference Signals chart on page 5-6.

10.4 Jog

The jogging frequency is immediately output when the remote JOG is activated. The functions [:JOG] and [:J.StP] must be preset. In addition, the JOG(SS2) terminal must be set for "JOG". This is accomplished by setting the function parameter [:l.tb] to 1 or 3. The terminal connections are shown below:

Terminal Connections Required For Remote Jog

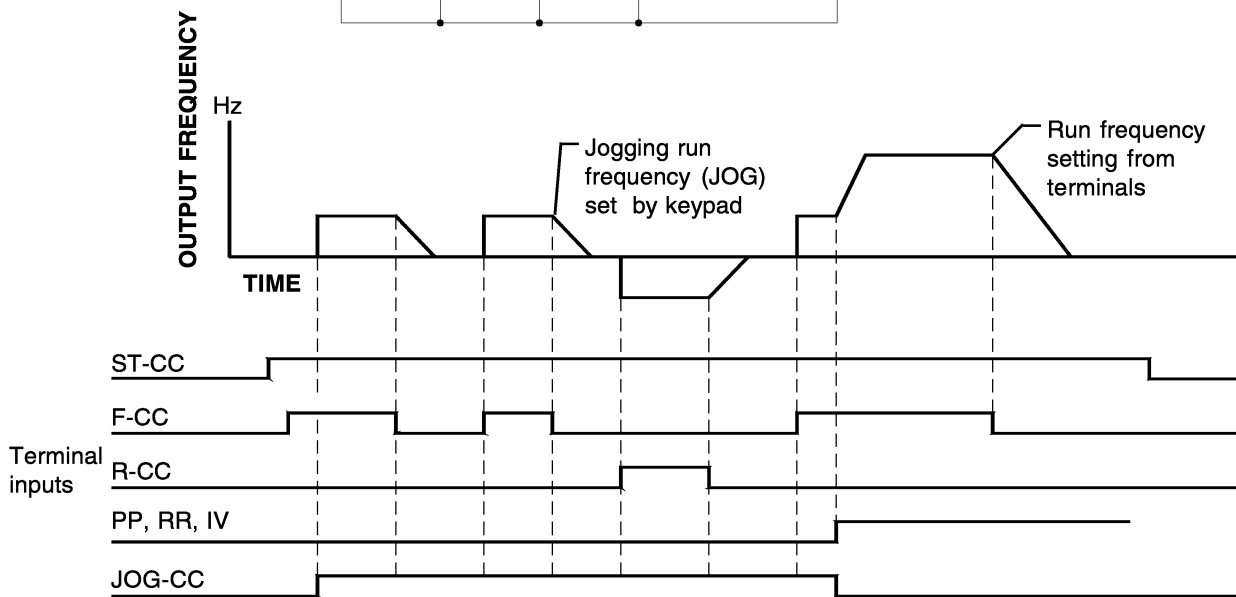
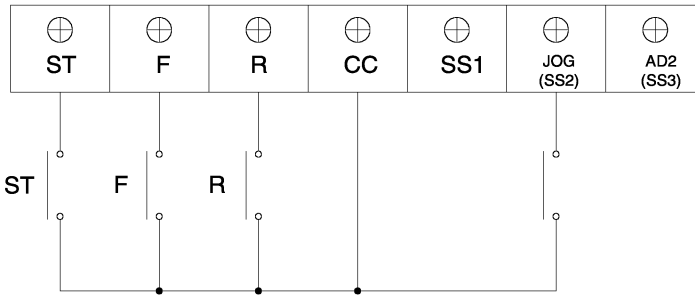

Notes:

- 1) A jogging run cannot be engaged by closing the JOG switch during a run.
- 2) The inverter will decelerate at the selected rate during: deceleration stop, coast to stop, and DC injection stop.
- 3) F-CC must be broken for DC injection to be applied; breaking only JOG(SS2)-CC allows the inverter to accept other input signals and is not a "true" off.
- 4) See table on next page for terminal inputs and actions.

10.5 Resetting After a Trip

Pressing reset on the keypad resets the inverter faults. Momentarily closing a normally open dry contact between terminals RST and COM resets the inverter faults remotely.



CAUTION

When the inverter trips due to an emergency stop or the activation of one or more of its protective functions, the cause of the fault must be corrected before resetting the inverter. A forced restart with out prior fault correction measures could damage the inverter and connected devices.

10.6 Pattern Run

The pattern run enables the user to run up to seven different speeds automatically, in either forward or reverse directions. It is an extension of the seven preset speeds described on page 9-9. Unlike the Preset Speed Function, the user can pre-select the length of time in which the inverter will operate at each frequency (Sr1~Sr7), as well as the acceleration/deceleration pattern used to reach each frequency.

The required preset function parameters are as follows:

- 1) Actual run frequencies (Sr1~Sr7) are located in Speed Group Parameter [:S.PrG] Item 2 through 8.
- 2) The run time for each of these frequencies in the pattern (Pt.1t~Pt.7t) is located in Pattern Frequency Group Parameters [:P.PrG] Item 6, 8, 10, 12, 14, 16, and 18.
- 3) The particular ACC/DEC drive characteristics, including the run direction, to be used is located in Pattern Frequency Group Parameters [:P.PrG] Item 7, 9, 11, 13, 15, 17, and 19.

The following graph shows a sample of a typical pattern run:

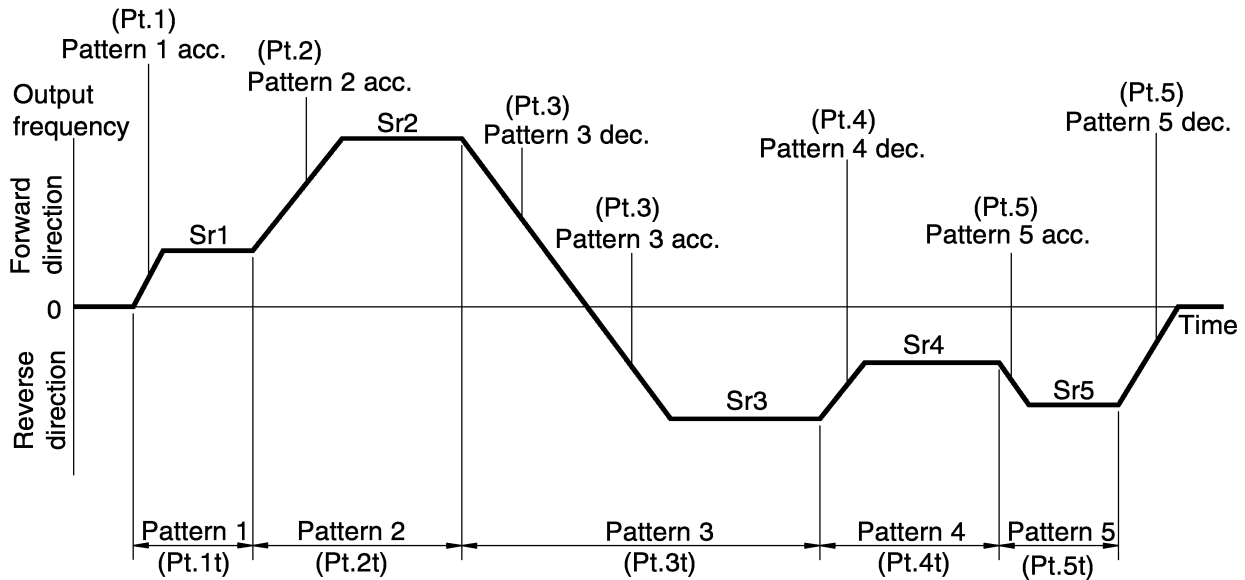

The run time set for each pattern includes the ACC/DEC time required to reach that particular run frequency. Therefore, care must be taken when choosing run times. For example, if the pattern run time is set for 30 seconds and the acceleration time required to reach the preset frequency is 20 seconds, then the actual run frequency would last only 10 seconds.

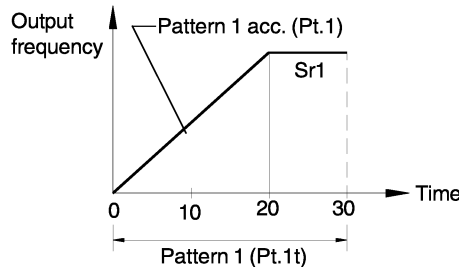

10.7 PID Set Point Control

All FLOWQSU inverters come standard with set point control. The following information shows how to install and adjust the inverter using set point control. The feedback signal should be either 0-5 volts or a 4-20mA current. It is connected to terminals IV and CC. The set point is adjusted by using a potentiometer. The diagram below shows how a potentiometer should be connected to terminals PP, RR, and CC to control the setpoint. Each of these connections are made to the Control/Driver Board terminal block (see detail Page 5-5). The connection diagram below shows the necessary wiring.

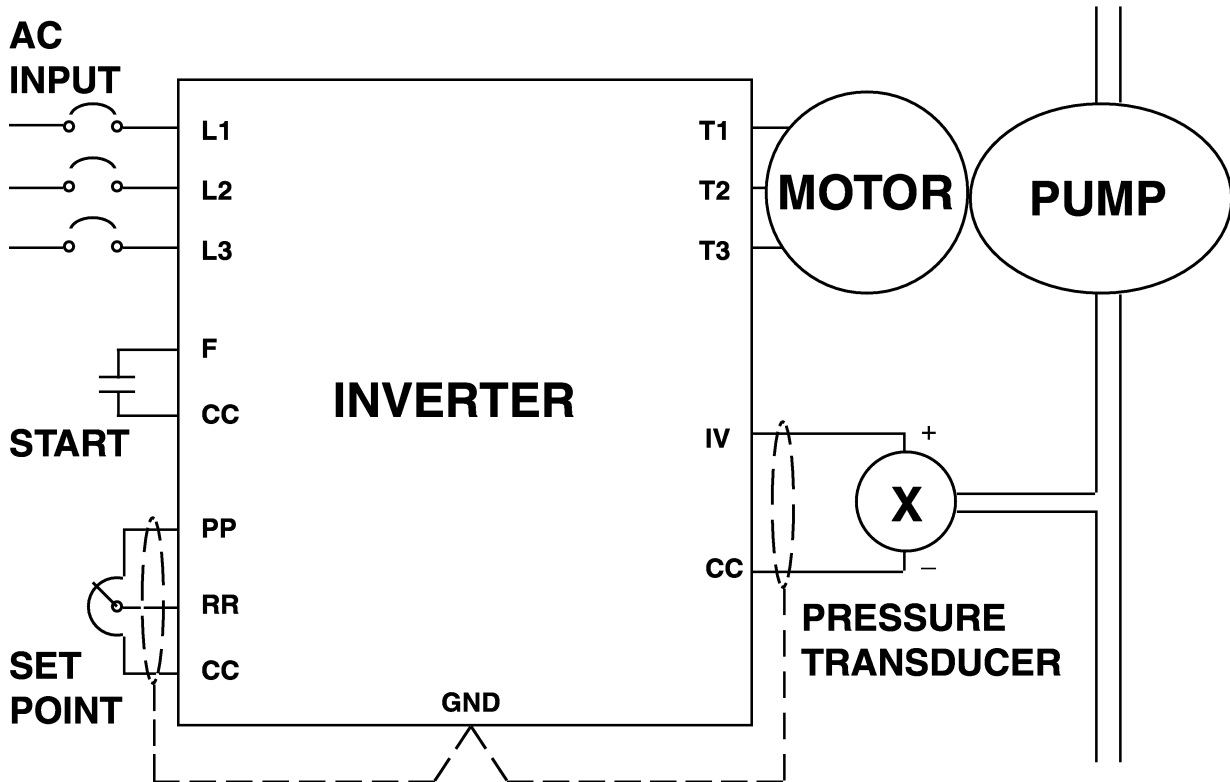

Use the following procedures to adjust the setpoint control parameters:

INITIAL SETUP

- 1) Remove power and place the jumper connections JP1 and JP2 (See detail 1 or 3 Page 5-5 and Jumper/Terminal Connections and Functions Page 5-6) in the correct positions for the type of feedback signal used; power can then be applied again.
- 2) Set acceleration and deceleration times to 5 seconds (see Setup Parameters Item # 1 and 2).
- 3) Adjust the bias and gain for the systems feedback signal. For example, typically the motor slows down when the feedback signal goes above the setpoint. This action can be reversed by exchanging the data between F-P1 and F-P2 (see Setup Parameters Item # 6 and 8).
- 4) Turn on the set point (PID) control (see Jump Frequency Group parameters Item #7).
- 5) Set proportional gain to 250 (see Jump Frequency Group parameters Item #8).
- 6) Set integral gain to 100 (see Jump Frequency Group parameters Item #9).
- 7) Set differential gain to 0 (see Jump Frequency Group parameters Item #10).
- 8) Set lag-time constant to 255 (see Jump Frequency Group parameters Item #11).
- 9) Run system.

10.7 PID Set Point Control (cont'd)

READJUSTMENT

- 1) For faster response time set larger proportional gain, shorter integral gain and/or shorter acceleration and deceleration times.
- 2) To stabilize the system adjust increase anti-hunting gain, increase lag-time constant and/or slow the response time.

HAVING TROUBLE?

Please check the following list. These are things which will cause the PID loop to operate incorrectly.

- 1) **FEEDBACK** - Make sure that the feedback signal has the correct polarity. Make sure that jumpers JP1 and JP2 (See Detail 1 or 3 on Page 5-5) are correctly set.
- 2) **SOFTWARE** - Make sure that the inverter main software is Version 5.3 (see Page 8-1 "Normal Status Monitoring").
- 3) **SETPOINT** - Make sure that the setpoint potentiometer is connected correctly.
- 4) **START** - Make sure that the drive is given a run command by either contact closure or pressing the keypad ***RUN*** button.

11.0 Output Terminal Operating Functions

The inverter provides terminals for outputting signals to external components. A number of selectable "operating" output signals, as well as "fault" output signals, are available. These output signal terminals are located on the terminal board (See Control/Driver Terminal Block Details on page 5-5).

11.1 Selectable Outputs

The output terminals RCH(UL) and LOW(LL) are multifunctional and are selectable through function [:0.tb] (See item 6 on page 7-3). The type of selections are available as shown below:

- LL Outputs a signal when frequency is greater than or equal to the LL value.
- UL Outputs a signal when frequency is equal to UL value.
- LOW Outputs a signal when frequency is greater than or equal to the LOW SPEED DETECTION VALUE "LF".
- RCH Outputs a signal based upon the selection of the RCH parameters rCH, rrCH, FrCH.

All output signals are open-collector with 50mAdc~24Vdc ratings.

The illustrations below show output timing diagrams for the upper and lower frequency limits and for low speed and speed reach signals.

Upper/lower limit frequency signal output

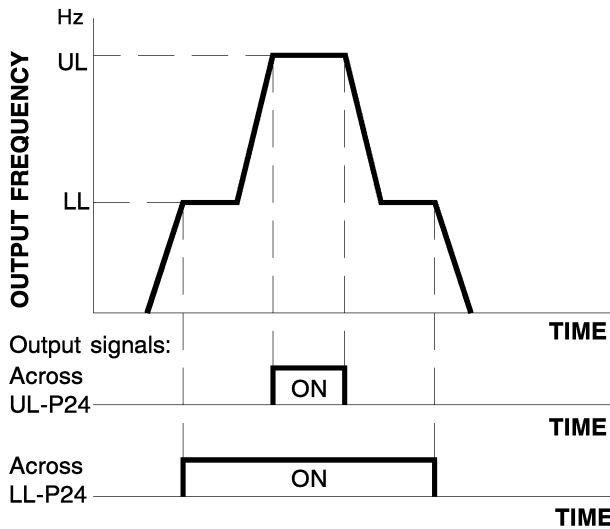

Low speed/speed reach signal output with [:rCH]=0

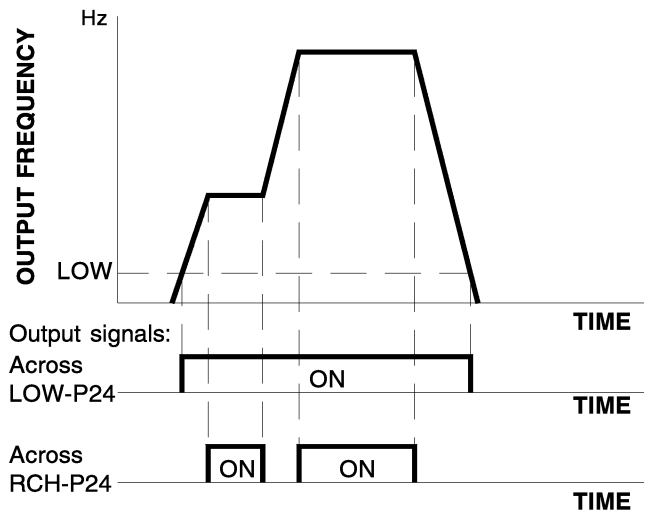

Low speed/speed reach signal output with rCH=1

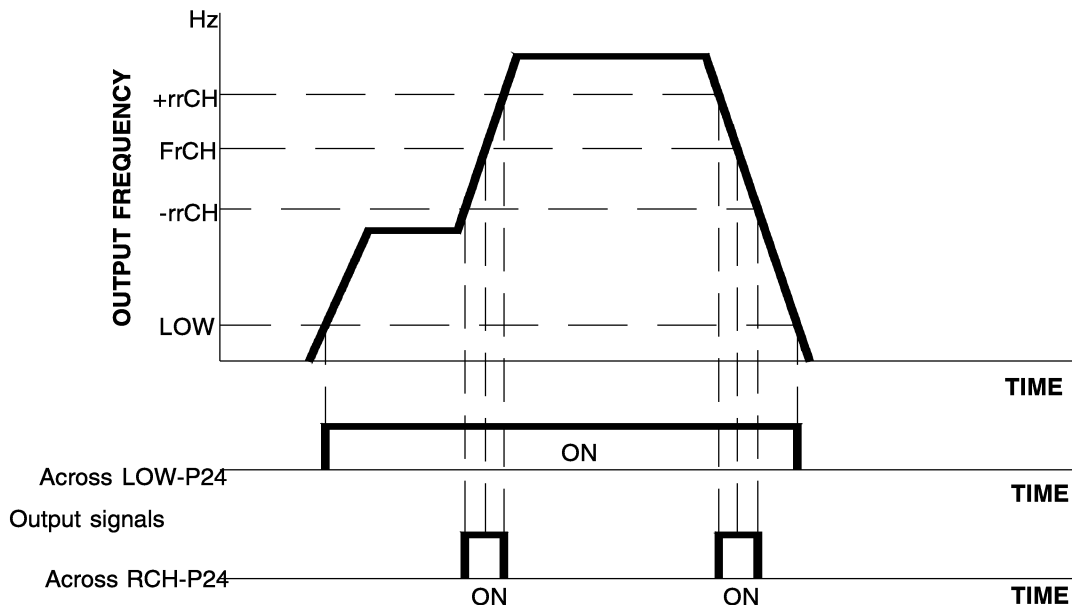

11.2 Inverter to Relay/PC Connections

Terminals RCH (UL) and LOW (LL) of the control circuit terminal block are open collector outputs which float in an open state. When the predesignated frequency has been reached the terminals can sink 24Vdc at 50mAdc to ground. P24 supplies 24Vdc through the relay coils to the RCH (UL) and LOW (LL) terminals for relay activation. Connections are shown below for either relay logic or programmable controller inputs. Notice that there is no difference in the circuits except how the relay outputs are utilized.

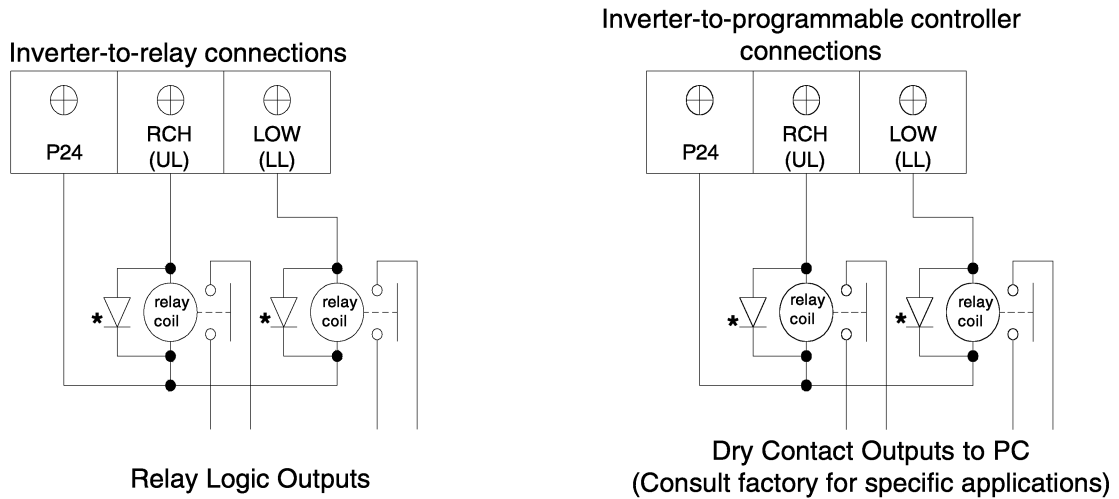

* Free-wheeling diode (Use 1amp 1000PIV or similiar) to be oriented across load so that it does not conduct during normal current flow.

Note: When an output frequency fluctuates in the vicinity of a frequency to be reached, the reach signal may alternately turn on and off because of the lack of hysteresis in the reach signal.

11.3 Fault-Detection Output Terminals

When any of the inverter's system protection features are activated and the inverter trips (See list of probable causes on Page 8-3), the cause of the problem will be displayed and a fault-detection relay will be activated. This will cause the contacts associated with the Fault-Detection Output Terminals to change state. Three fault detection terminals FLA, FLB, and FLC are provided as a NO, NC form C contact rated for a 250Vac/30Vdc 2A output.

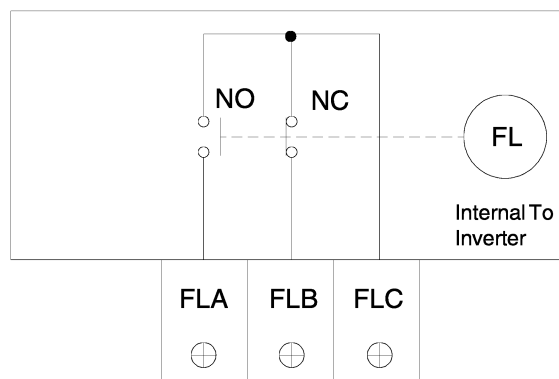

11.4 Calibration of Remote Meters

Many times an application requires that a frequency meter (FM) or ammeter (AM) be remotely located. Attachment and calibration of a remote meter is a easy procedure. The meter leads should be connected to the appropriate terminals while observing correct polarity. The calibration of the meter is performed with the inverter keypad while observing the meter. The meter should be zeroed with the set screw before calibrating. If the meter is not visible from the inverter site, then the meter should be viewed periodically as the keypad is adjusted. Also the meter can be connected through a temporary length of cable for easy viewing. This temporary cable should be the same size and length as the permanent cable.

Use the following diagram for connecting a Frequency Meter (FM):

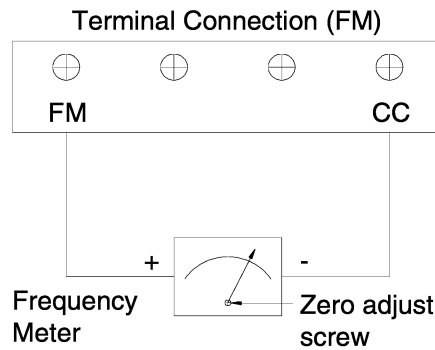

Note: Use a 1mA_{dc} ammeter or 7.5V_{dc} voltmeter. Connect the meter across terminals FM-CC. Use shielded cable (1000 ft. maximum length).

Use the following procedure to calibrate the (FM) meter:

- 1) Start the inverter to output a run frequency such as 60 Hz **60.0**
- 2) Press "down" key while pressing **CLEAR/RESET** key to display **:F 7**
- 3) Press the **RUN** key to display **:60.0**
- 4) Adjust the analog meter reading to match the digital display reading by pressing the "up" or "down" keys.
- 5) Press the **READ/WRITE** key to store this setting to non-volatile EEPROM memory.
- 6) Press the **CLEAR/RESET** key to return to the normal frequency display **60.0**

Although the above procedure shows calibration of the remote meter at a running frequency of 60Hz; better resolution of the meter can be obtained if the inverter is running at the maximum frequency. ***The motor load should be disconnected for FM calibration at the highest frequency.***

11.4 Calibration of Remote Meters (cont'd)

Use the following diagram for connecting a Frequency Meter (AM):

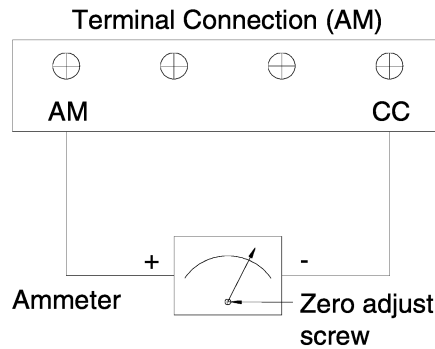

Note: Use a 1mA dc ammeter or 7.5V dc voltmeter. Connect the meter across terminals AM-CC. Use shielded cable (1000 ft. maximum length).

Use the following procedure to calibrate the (AM) meter:

- 1) Start the inverter to output a run frequency such as 60 Hz 60.0
- 2) Press "down" key while pressing **CLEAR/RESET** to display : F 1 1
- 3) Press either the "up" or "down" key to display : 9 1 1
- 4) Press the **RUN** key to display : [] [value]
- 5) Adjust the analog meter reading to match the digital display reading by pressing the "up" or "down" keys.
- 6) Press the **READ/WRITE** key to store this setting to non-volatile EEPROM memory.
- 7) Press the **CLEAR/RESET** key to return to the normal frequency display 60.0

12.0 After Sales Service/Service Life

12.1 Requesting After Sales Service

When requesting after-sales service, report the contents of the following PROBLEM INFORMATION SHEET, which will help repair the system quickly.

Problem Information Sheet

Item			
	Customer's name		
Refer to	Person in charge		
	Address		
	Telephone No.		
Inverter spec.	Model No.		
	Serial No.		
	Test No.		
Delivery date			
Time in service			
Date when problem arose			
	Use		
Status of Use	Motor rating	Poles, Hp, V, Hz.	
		Made by Toshiba? Made by another company?	
		New? Number of units?	
		Alternate? Continuous?	
	Ambient condition	Indoor? Outdoor? Temperature range?	
		Humidity:	
		Dust composition and size:	
		Presence of salt and extent of corrosion from it:	
		Vibrations, in micrometers:	
		Presence of corrosive gas:	
Availability of air conditioning:			
Phenomenon	Power source	Number of phases:	
		Voltage between L1 phase and L2 phase:	
		Voltage between L2 phase and L3 phase:	
		Voltage between L3 phase and L1 phase:	
	State of motor when problem was found	Number of Hz:	
		Problem occurred hours after motor had been started. Motor has been stopped for hours.	
		Problem occurred during periodic inspection?	
		Problem occurred when motor was started?	
		Problem occurred during acceleration?	
		Problem occurred during deceleration?	
	Frequency of problem	Problem occurred while motor was not running?	
		First time? Problem occurred times in the past.	
		Problem occurs sometimes?	
		Problem occurs every time motor is operated?	
Trouble indicator	When did problem first occur?		
	<input type="checkbox"/> NO DISPLAY <input type="checkbox"/> OC1 <input type="checkbox"/> OC2 <input type="checkbox"/> OC3 <input type="checkbox"/> OCA <input type="checkbox"/> OCL <input type="checkbox"/> OP2 <input type="checkbox"/> OP <input type="checkbox"/> OL <input type="checkbox"/> OH <input type="checkbox"/> EF <input type="checkbox"/> Err.2 <input type="checkbox"/> Err.3 <input type="checkbox"/> Err.4 <input type="checkbox"/> Err.5 <input type="checkbox"/> Err.6 <input type="checkbox"/> EEP <input type="checkbox"/> EEP2 <input type="checkbox"/> EEP3 <input type="checkbox"/> ERR.t		
Detailed description of problem:			
Temporary diagnosis and corrective action:			
Date defective product shipped:		To:	
Deadline for repairs:			

Only qualified personnel should be allowed to service this equipment.

12.0 After Sales Service/Service Life**12.2 Parts Service Life**

In order to obtain the best performance and to get the maximum service life from the inverter it is necessary to perform timely maintenance repairs on some parts of the system even though the equipment may still be functioning with no apparent problems

Use the following service life chart as a guide for major part periodic replacement when the equipment is used in a standard installation service environment.

Service Life Replacement Chart

Part Name	Service Life	Remarks
Large capacity electrolytic capacitor	5 Years	To be electrified semiannually in case of long term disuse.
Cooling Fan	3 Years	
Contact relays	500,000 operations	
Connectors	100 operations	Replace pin in case of failure.

13.0 Dimensions/Weights

13.1 Basic Dimensions

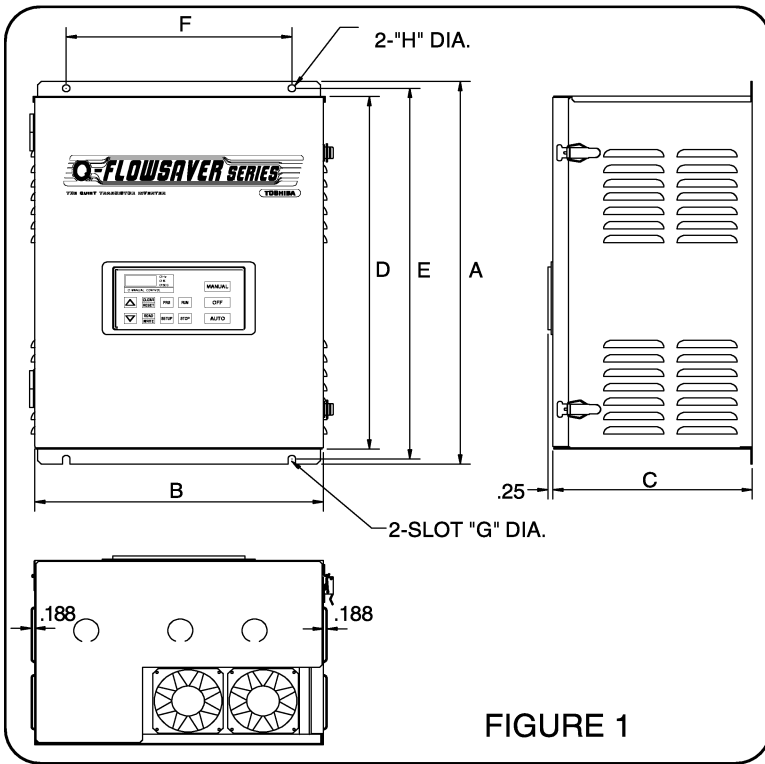

FIGURE 1

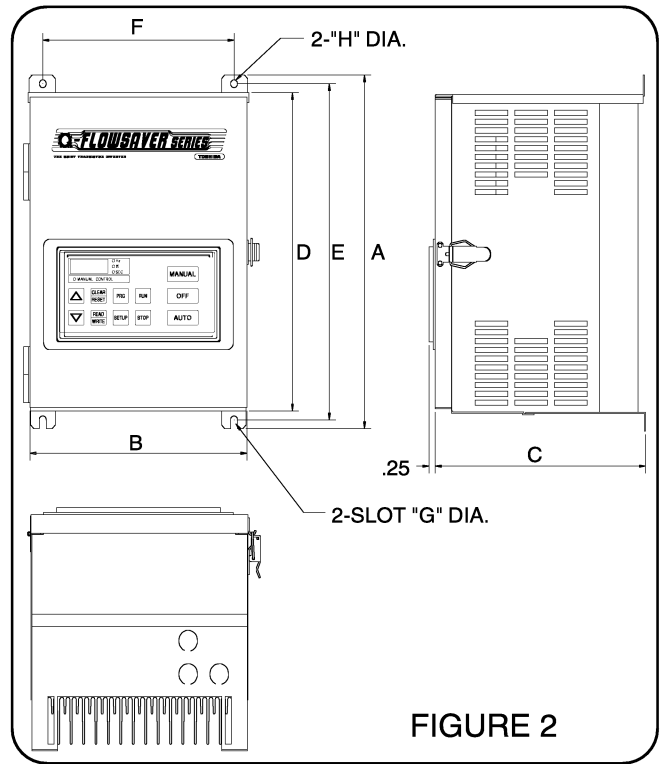

FIGURE 2

Enclosure and Conduit Dimensions in inches(millimeters)

FLOWQSU Models	Fig No	Dim A	Dim B	Dim C	Dim D	Dim E	Dim F	Dim G	Dim H	Conduit (Qty) Size
FLOWQSU2035	2	12.63(321)	8.72(221)	8.41(214)	11.38(289)	12.00(305)	7.69(195)	.28(7)	.28(7)	(3) 0.5(13) Dia
FLOWQSU2055	2	12.63(321)	8.72(221)	8.41(214)	11.38(289)	12.00(305)	7.69(195)	.28(7)	.28(7)	(3) 0.5(13) Dia
FLOWQSU2080	1	18.75(476)	14.38(365)	9.94(252)	17.13(435)	18.09(459)	11.25(286)	.38(10)	.38(10)	(3) 1.0(25) Dia
FLOWQSU2110	1	18.75(476)	14.38(365)	9.94(252)	17.13(435)	18.09(459)	11.25(286)	.38(10)	.38(10)	(3) 1.0(25) Dia
FLOWQSU2160	1	20.75(527)	14.38(365)	9.94(252)	19.13(486)	20.09(510)	11.25(286)	.38(10)	.38(10)	(3) 1.0(25) Dia
FLOWQSU2220	1	20.75(527)	14.38(365)	9.94(252)	19.13(486)	20.09(510)	11.25(286)	.38(10)	.38(10)	(3) 1.0(25) Dia
FLOWQSU2270	1	23.63(600)	17.38(441)	11.50(292)	21.63(549)	22.75(578)	14.25(362)	.50(13)	.50(13)	(3) 1.25(32) Dia
FLOWQSU2330	1	36.50(927)	19.25(489)	13.56(344)	33.88(861)	35.34(898)	12.63(321)	.63(16)	.63(16)	(4) 1.25(32) Dia
FLOWQSU4055	2	12.63(321)	8.72(221)	8.41(214)	11.38(289)	12.00(305)	7.69(195)	.28(7)	.28(7)	(3) 0.5(13) Dia
FLOWQSU4080	2	16.38(416)	8.72(221)	8.41(214)	15.06(383)	15.75(400)	7.69(195)	.28(7)	.28(7)	(3) 0.5(13) Dia
FLOWQSU4110	1	18.75(476)	14.38(365)	9.94(252)	17.13(435)	18.09(459)	11.25(286)	.38(10)	.38(10)	(3) 1.0(25) Dia
FLOWQSU4160	1	18.75(476)	14.38(365)	9.94(252)	17.13(435)	18.09(459)	11.25(286)	.38(10)	.38(10)	(3) 1.0(25) Dia

13.0 Dimensions/Weights

13.1 Basic Dimensions (cont'd)

Conduit in inches (millimeters)

FLOWQSU Models	Fig No.	Conduit (Qty) Size
FLOWQSU4220	3	(3) 1.0(25) Dia
FLOWQSU4270	3	(3) 1.0(25) Dia
FLOWQSU4330	3	(3) 1.0(25) Dia
FLOWQSU4400	3	(3) 1.0(25) Dia
FLOWQSU4500	3	(3) 1.0(25) Dia
FLOWQSU4600	3	(1) 1.0(25) Dia and (2) 2.0(51) Dia
VT130QSU4800	3	(1) 1.0(25) Dia and (2) 2.0(51) Dia
VT130QSU410K	3	(1) 1.0(25) Dia and (2) 2.0(51) Dia

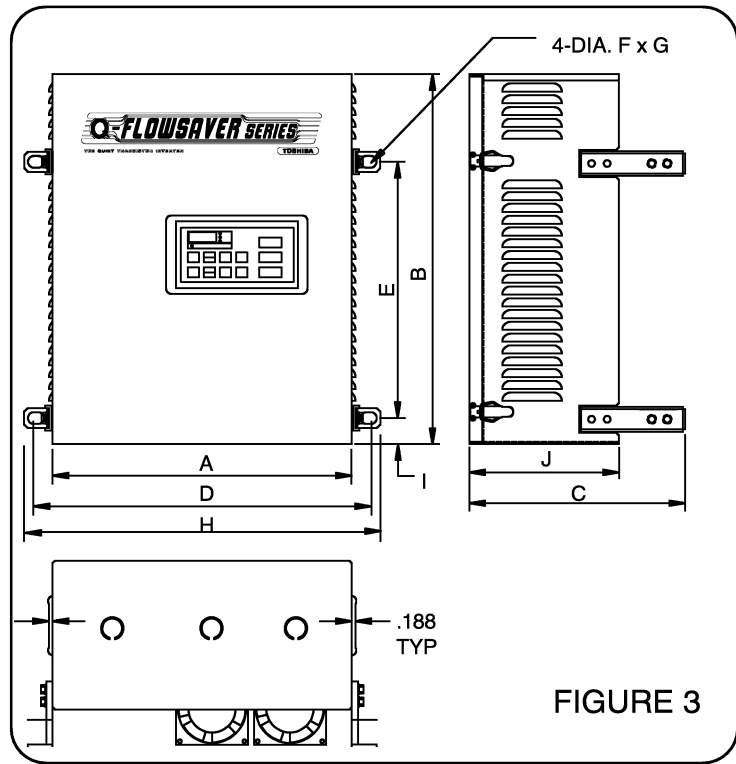

FIGURE 3

Enclosure Dimensions in inches (millimeters)

FLOWQSU Models	Fig No.	Dim A	Dim B	Dim C	Dim D	Dim E	Dim F	Dim G	Dim H	Dim I	Dim J
FLOWQSU4220	3	17.63(448)	22.38(568)	10.88(276)	19.06(484)	14.75(375)	0.59(15)	0.81(21)	20.25(514)	1.25(32)	7.59(193)
FLOWQSU4270	3	17.63(448)	22.38(568)	10.88(276)	19.06(484)	14.75(375)	0.59(15)	0.81(21)	20.25(514)	1.25(32)	7.59(193)
FLOWQSU4330	3	17.63(448)	22.38(568)	10.88(276)	19.06(484)	14.75(375)	0.59(15)	0.81(21)	20.25(514)	1.25(32)	7.59(193)
FLOWQSU4400	3	20.19(513)	25.56(649)	12.38(314)	21.63(549)	19.03(483)	0.59(15)	0.81(21)	22.81(579)	1.25(32)	8.75(222)
FLOWQSU4500	3	20.19(513)	25.56(649)	12.38(314)	21.63(549)	19.03(483)	0.59(15)	0.81(21)	22.81(579)	1.25(32)	8.75(222)
FLOWQSU4600	3	20.19(513)	36.19(919)	13.25(337)	22.06(560)	26.00(660)	0.59(15)	0.81(21)	22.81(579)	2.06(52)	8.53(217)
FLOWQSU4800	3	20.19(513)	36.19(919)	13.25(337)	22.06(560)	26.00(660)	0.59(15)	0.81(21)	22.81(579)	2.06(52)	8.53(217)
FLOWQSU410K	3	20.19(513)	36.19(919)	13.25(337)	22.06(560)	26.00(660)	0.59(15)	0.81(21)	22.81(579)	2.06(52)	8.53(217)

13.0 Dimensions/Weights

13.2 Operating Panel Assembly

(NEMA 4/NEMA 12 Operation Panel - Standard)

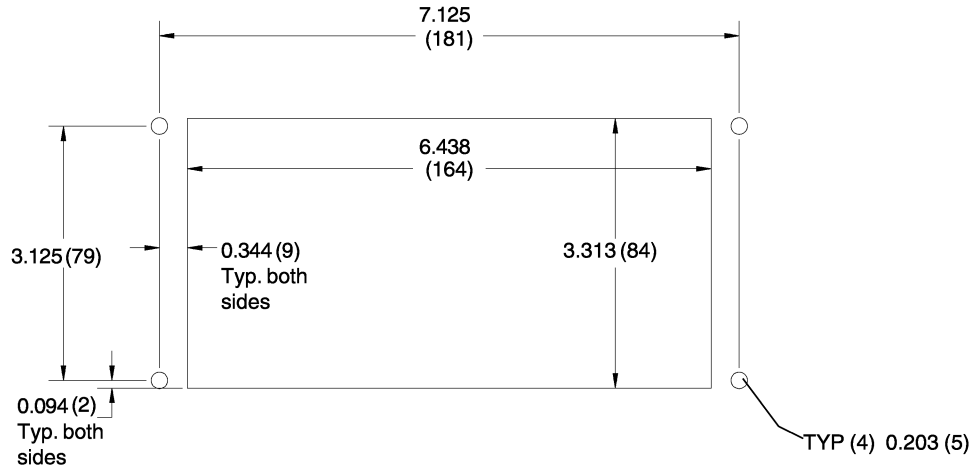

**CUTOUT FOR TOUCH-PAD
OPERATION PANEL IN DOOR
(FRONT VIEW)**

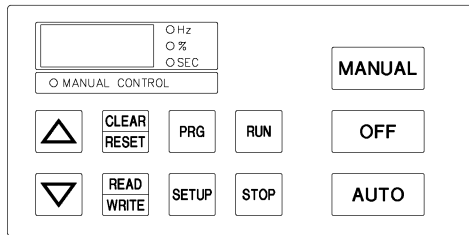

**FRONT VIEW OF
TOUCH-PAD
OPERATION PANEL**

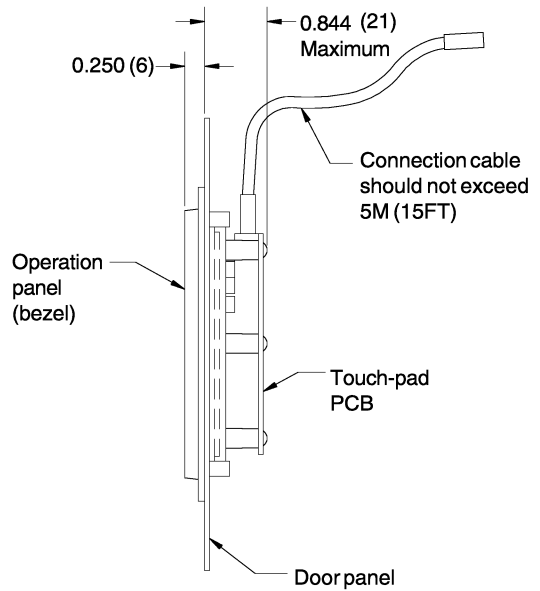

**RIGHT SIDE
VIEW**

DIMENSIONS ARE IN INCHES(MILLIMETERS)

13.0 Dimensions/Weights**13.3 Shipping Weights**

FLOWQSU Models	Shipping Weight		
	Type	Pounds	Kilograms
FLOWQSU2035		20	9.1
FLOWQSU2055		20	9.1
FLOWQSU2080		51	23.1
FLOWQSU2110		51	23.1
FLOWQSU2160		61	27.7
FLOWQSU2220		63	28.6
FLOWQSU2270		105	47.6
FLOWQSU2330		172	78.0
FLOWQSU4055		22	10.0
FLOWQSU4080		37	16.8
FLOWQSU4110		61	27.7
FLOWQSU4160		63	28.6
FLOWQSU4220		111	50.3
FLOWQSU4270		112	50.8
FLOWQSU4330		118	53.5
FLOWQSU4400		140	63.5
FLOWQSU4500		143	64.9
FLOWQSU4600		208	94.3
FLOWQSU4800		230	104.3
FLOWQSU410K		240	108.9

TOSHIBA

TOSHIBA INTERNATIONAL CORPORATION

INDUSTRIAL DIVISION

13131 West Little York Rd., Houston Texas 77041

Tel: [713] 466-0277 Fax: [713] 466-8773