

Introduction

The electromagnetic flowmeter uses Faraday's Law of electromagnetic induction to measure the process flow. The device consists of two units: a detector, through which the fluid to be measured flows and in which low-level signals proportional to flow rates are obtained; and a converter, which supplies excitation current to the detector, and amplifies the signals from the detector and then processes and converts the signals into the 4–20 mA dc current signal. The LF470 is a small meter size detector designed to measure a small amount of fluids containing substances such as chemicals.

The wetted materials for the LF470 are corrosion resistant ceramic and platinum electrodes and are applicable to almost any kind of fluids. The LF470 is a lightweight palm-sized detector. Combined with multi-functional converter LF622 (separate type) and LF232*¹ (separate type) equipped with its patented **Noise-Sentry** original noise-suppression circuit and advanced algorithms. The LF470 is highly resistant to noise and provides a stable output even for fluids containing slurries. IR (Infrared) switches enable parameter setting of the converter without removing the cover. Flow direction can be set in either way, and its unique 128 x 128 dot matrix LCD display allows the LCD to be rotated electronically to be rotated to 90, 180 and 270 degrees without opening the cover

- *1: Please refer to the document "TIC-LF232".
- *2: HART protocol (Highway Addressable Remote Transducer) is a communication protocol for industrial sensors recommended by the HCF (HART Communication Foundation).
** DevComm2000 Smart Device Communicator available for performing HART device configurations on PC or laptop is available through the supplier.
- *3: PROFIBUS is the communication protocol for factory and process automation that the PROFIBUS Organization recommends. Instead of analog control with a conventional analog signal (4-20mA), it is the fieldbus which digitizes all signals. Flowmeters support PROFIBUS-PA.
- *4: Modbus is the communication protocol that Modicon Inc. developed. Physical layer is RS485.
- * Modbus is the communication protocol that Modicon Inc. developed. Physical layer is RS485.

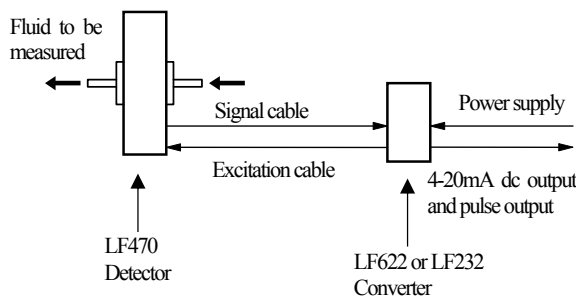
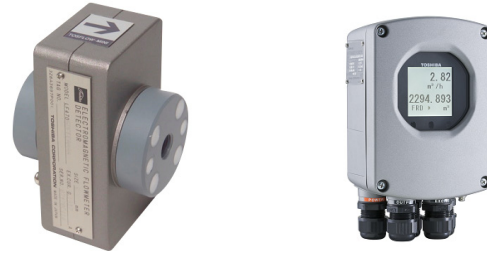

Figure 1. Configuration Diagram



LF470 **LF622**
Figure 2. Electromagnetic Flowmeter
LF470/LF622



Certification number
Z01207

Specifications

■ Overall Specifications

Measurement range in terms of flow velocity:
1.0ft/s to 32.8ft/s (0.3 m/s to 10 m/s)

Accuracy: The overall accuracy combined with the LF622 or LF232 converter is shown in the following table.

Flow rate as a percent of range	Accuracy	
	1.0-3.3ft/s (0.3-1.0m/s)	3.3-32.8ft/s (1.0-10m/s)
50~100%	±0.8% of FS	±0.8% of rate
0~50%	±0.8% of FS	±0.4% of FS

Note: The accuracy is measured under standard operating conditions at Toshiba's calibration facility.

Fluid conductivity: 50µS/cm minimum

Fluid temperature:

Pipe connection material	Fluid temperature
Stainless steel and other metals	14 to 248 °F (-10°C~+120°C)
Polyvinyl chloride (shock-resistant)	14 to 140 °F (-10°C~+60°C)

Ambient temperature: 14 to 140 °F (-10 to +60 °C)

Structure: IP67

Power consumption:

- When combined with the LF622 converter:

Standard: 10W(14VA)

at AC100V and Excitation current: 0.2A

MAX: 15W (22VA)

MAX: 17W(24VA) with PROFIBUS

- When combined with the LF232 converter:
Approximately 14W (25VA)

■ Model LF470 Detectors

Fluid pressure: -15 to 150 psi, or -1.0 to 10 bar
(-0.1 to 1 MPa)

Principal materials:

Measurement tube – Alumina ceramics

Electrodes – Platinum

Pipe connection port:

Standard – 316 stainless steel

Option – Ti (titanium),
Polyvinyl chloride (shock-resistant)+
Ta (Tantalum) for grounding plate,
Polyvinyl chloride (shock-resistant)+
Pt-Ir grounding plate,
Hastelloy C (Equivalent)

Dedicated preformed cables:

- Signal cable – 2-wire shielded chloroprene sheathed cable
Overall length: 0.28 inch (7mm)
Length: 0.20 inch (5m)
- Excitation cable – 3-wire chloroprene sheathed cable
Overall length: 0.28 inch (7mm)
Length: 0.20 inch (5m)

Coating: phthalic acid resin coating pearl-gray colored

Weight: approximately 2.2 lb (1.0 kg)
(for each size excluding cables)

■ Model LF622 converters

Input signals

Analog signal — the voltage signal from detector, proportional to process flow rate (for LF622 separate type converter).

Digital input DI

Signal type: 20 to 30Vdc voltage signal
Input resistance: 2.7k Ω
Number of inputs: one point

Note: DI cannot be used with the Modbus communication.

DI function — One of the following functions can be assigned to the DI signal.

Range switching — Selects either the higher or lower range in the unidirectional or bidirectional 2-range setting.

Totalizer control — ‘Starts and stops’ or ‘Rest and start’ the built-in totalizer.

Fixed-value outputs — Outputs fixed-values for current and pulse outputs for loop check.

Zero adjustment — Executes zero adjustment (on-stream at zero flow rate).

Output signals

Current output:

4–20mA_{dc} (load resistance 0 to 750 Ω)

Note: The current output cannot be used with the PROFIBUS-PA communication.
(Refer table 6 for details)

Digital outputs — Two points are available as follows.

Digital output DO1 :

Output type: Transistor open collector

Number of outputs: One point

Output capacity: 30V_{dc}, 200mA maximum

Note: DO1 cannot be used if Modbus communication connection is 3 lines.(Refer table 6 for details)

Digital output DO2 :

Output type:

Solid-state relay output (non polarity)

Number of outputs: One point

Output capacity: 150V_{dc}, 150mA maximum

or 150V_{ac} (peak to peak), 100mA maximum

Note: DO2 cannot be used with the Modbus communication.(Refer table 6 for details)

DO1 and DO2 functions — One of the following functions can be assigned to DO1 and/or DO2.

• **Pulse output (available only for DO1, DO2)**

Pulse rate: Max 10kHz (10,000pps) (DO1)

Max 100Hz (100pps) (DO2)

(Over 1kpps, auto-setting)

Pulse width: 0.3 to 500ms (but less than half of the period for 100% flow rate)

Note: The same and simultaneous pulse is not available between DO1 and DO2.)

• **Multi-range selection outputs (Note 1)**

• **High, High high, Low, and/or Low low alarm outputs (Note 2)**

• **Empty pipe alarm output**

• **Digital Output Active Status (DO1 and DO2) (Note 2)**

• **Preset count output**

• **Converter failure alarm output**

Note 1: Two outputs (DO1 and DO2) are needed for 4-range switching and forward/reverse 2-range switching.

Note 2:Normal Open (default set) or Normal Close is selected for alarm outputs when programming. When power failure occurs, unit will be fault to Normal Open.

Communications output :

- **HART (std.)** — Digital signal is superimposed on 4–20mA_{dc} current signal as follows:
 - Conforms to HART protocol
 - Load resistance: 240 to 750Ω
 - Load capacitance: 0.25μF maximum
 - Load inductance: 4mH maximum
- **PROFIBUS(opt.)**
 - Protocol: PROFIBUS-PA
 - Baud rate: 31.25kbps
 - Bus voltage: 9-30VDC
 - Consumption electric current of bus: less than 16mA
 - Manufacture Ident-No.: 093B_{HEX}
 - Standard Ident-No.: 9740_{HEX}
 - Slave address: 0-126 (Default address is 126)
 - Profile: Profile Ver.3.01 for Process Control Devices
 - Function blocks: AI(Flow)×1 , Totalizer×1
- **Modbus (opt.)**
 - Physical layer : RS485
 - Protocol : Modbus
 - Mode : RTU
 - Baudrate : 4800, 9600, 19200bps
 - Data length : 8bit
 - Parity bit : None, Odd, Even
 - Stop bit : 1bit, 2bit
 - Error check : CRC-16
 - Max. station number : 32(with Master device)
 - Max. cable length : 1.2km (Note)
 - Note: This length is specification of 3 line connection.

LCD display:

Full dot-matrix 128×128 dot LCD display
(back-light provided)

Parameter settings — Parameters can be set as follows:

- **IR Switches:** Three key switches are provided to set configuration parameters.
- **Digital communication:** HART or PROFIBUS or Modbus is needed to set parameters.
- **Zero adjustment:** Zero point adjustment can be started by pressing the switch in the converter.
- **Damping:** 0.1 to 60 seconds (selectable in one second increments)

“Field re-verification” Mag-Prover – Toshiba’s Zero span calibration tool allows unit to be re-calibrated and verified using an internal software program. (For more information contact Toshiba International Corp.)

Conditions when power fails:

Parameter setting values are stored in non-volatile memory and the values will be restored when the power returns to normal condition. The outputs and display will remain as follows when power fails.

- Current output: 0mA_{dc}
- Digital output: OFF
- LCD display: No display
- HART: No communication
- PROFIBUS: No communication
- Modbus:: No communication

Power supply:

One of the following can be selected:

- 100 to 240Vac, 50/60Hz
(allowable voltage 80 to 264Vac)
110Vdc
(allowable voltage 90 to 130Vdc)
- 24Vdc (allowable voltage 18 to 36Vdc)

Surge protection:

Arresters are installed in the power supply and a current signal output circuit to help protect the meter from lightning and improve personnel safety.

Case: Aluminum alloy (equal to IP 67)

Coating: Acrylic resin-baked coating, pearl-gray colored

Cable connection port:**Cable glands** —

Provided as standard, Outer Diameter of cable ϕ 11 to 13mm

Material Nylon 66

G (PF) 1/2 male threads.

Applicable diameter —

0.433 to 0.512 inch (11 to 13mm)

Note: When PROFIBUS option is specified, cable gland size is ϕ 6~8mm for signal cable, ϕ 11~13mm for power cable

Vibration resistance:

No resonance to the following levels of vibration:

- 10 to 150Hz with acceleration of 9.8m/s²
- Vibration of 30Hz with 29.4 m/s² in 4h in each direction will not cause any defect to unit.

Note: Avoid using the flowmeter in an environment with constant vibration.

Dimensions :

See Figure 5

MTBF:

Converter: 220,000 hours (25 years) at 77 °F (25 °C)
based on strict military specification
MIL-HDBK-217F

Detector: 350,000 hours (40 years) at 77 °F (25 °C)
based on strict military specification
MIL-HDBK-217F

Installation

■ Dimensions

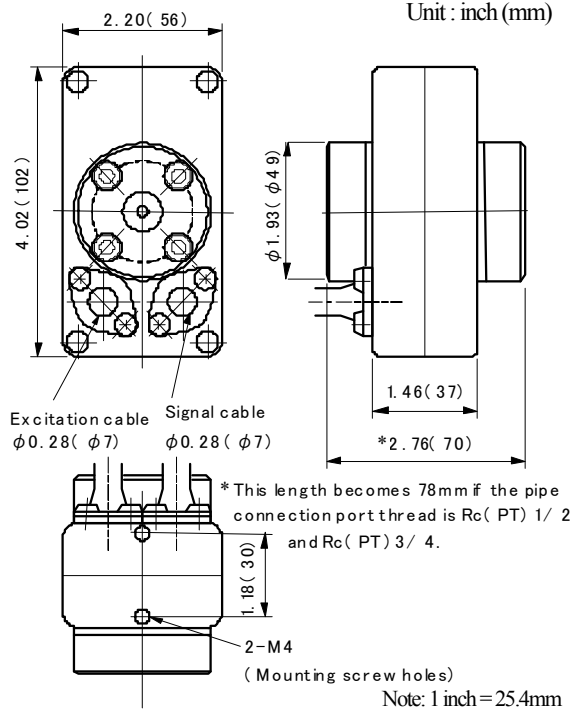
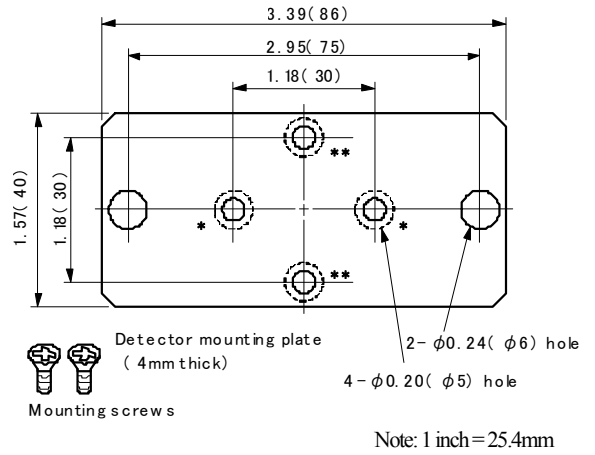

Figure3. LF470 Dimensions



If a mounting plate is needed for the LF470, fix the plate (a) above to the bottom of the LF470. Depending on which pair of screw holes used, the mounting angle changes by 90° .

Figure4. LF470 Mounting Board

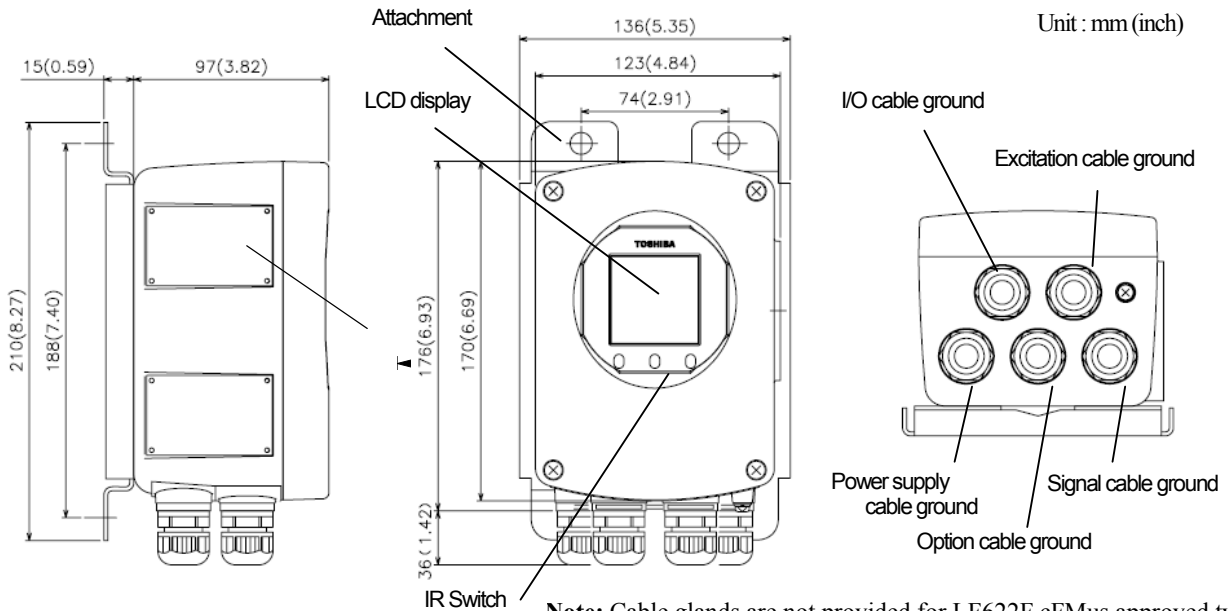

Figure 5. Separate type converter LF622

Separate type LF470/LF622 flowmeter

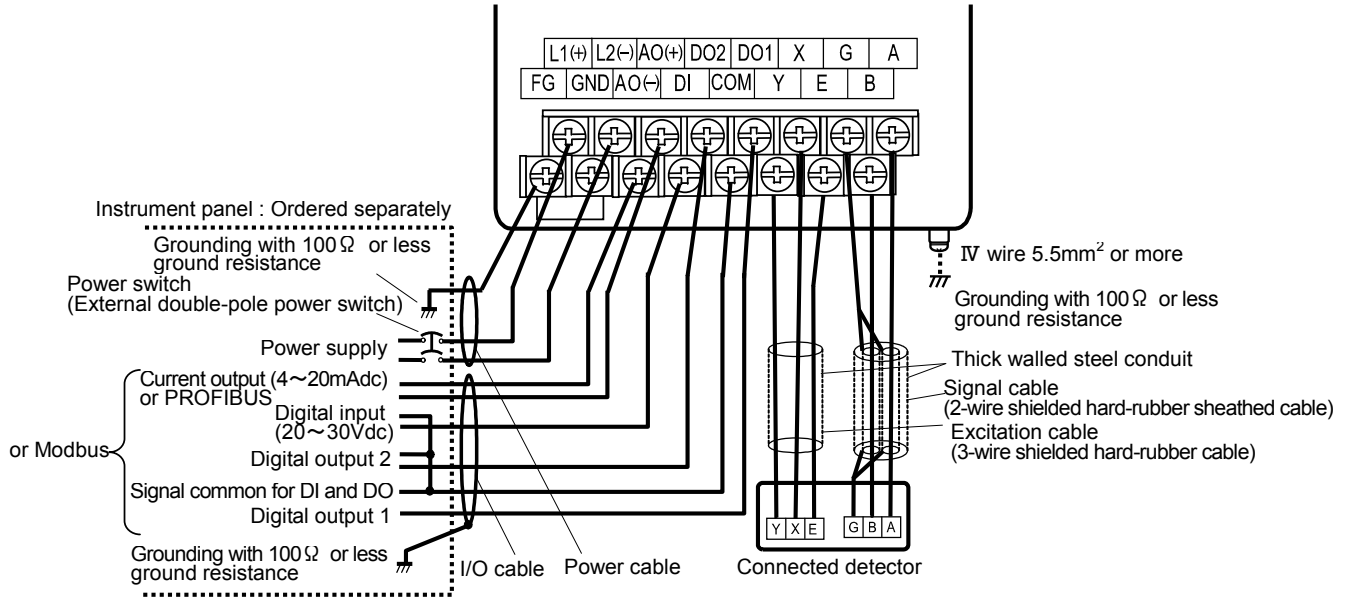

Figure 6. Separate type LF470/LF622 flowmeters wiring Diagram

Table 1. LF622 Converters Signal Table

Symbol	Description	Cable
L1 (+)	Power supply	Power cable
L2 (-)		
GND	Ground (for arrester)	
FG	Frame ground	
DI	Digital Input (20~30Vdc)	I/O cable
DO1	Digital Output 1	
DO2	Digital Output 2	
COM	Signal Common for DI, DO1, DO2	
+	Current Output (4~20mA dc) or PROFIBUS	Shielded cable for PROFIBUS-PA
-		
X	Excitation Output	Excitation cable (for LF622, LF622F only)
Y		
E		
A	Signal Input	Signal cable (for LF622, LF622F only)
B		
G		

Note: Symbol of the terminal is changed as follows for Modbus.

DO2 → T+, DI → T-, COM → TG

Symbol	Description	Cable
T+	Modbus(+)	Twist-pair polyethylene insulated vinyl sheath cable (JKEV,AWG24(0.2mm ²))
T-	Modbus(-)	
TG	Modbus(GND)	

■ **Wiring Precautions**

- (1) Connect the following two cables correctly:
 - 1) signal cable (on the right facing the LF470)
 - 2) excitation cable (on the left facing the LF470)
- (2) Do not bend applying excessive force to these cables.

■ **Piping Precautions**

- (1) Connect the fluid pipe to the pipe connection port using a joint that matches the Rc (PT) female screw. Use seal tapes when connecting the pipe to the port to prevent a fluid leakage. Do not tighten the connection screw too much.
- (2) Design piping so that the detector's pipe is always filled with the fluid to be measured, whether the fluid is flowing or not.
- (3) The fluid to be measured must be held still in the pipe when the LF470 is being adjusted. If the fluid can not be stopped after the LF470 installation, install a bypass pipe in parallel with the LF470 flowmeter.

■ **Meter size**

To select the meter size:

See Table 2 to 4 and find meter sizes within the velocity of 0.3 to 32.8 ft/s (0.1 to 10m/s) for a specified full-scale (measuring range high limit) flow. Select one that has its full-scale velocity between 3.0 and 10 ft/s (1 and 3m/s).

Note: Make sure the full-scale flow rate used for the final planning stage stays within 32.8 ft/s (10m/s) in terms of flow velocity.

Table 2. Meter size and Flow Velocity (SI unit)

Meter size (inch)	Unit:gal/min			
	0.98 ft/s	3.0 ft/s	10 ft/s	32.8 ft/s
1/10"	0.02334	0.07115	0.2372	0.7781
1/6"	0.05975	0.1821	0.6071	1.992
1/4"	0.1344	0.4098	1.3660	4.482

Table 3. Meter size and Flow Velocity (English unit)

Meter size (mm)	Unit:L/min			
	0.3 m/s	1.0 m/s	3.0 m/s	10 m/s
2.5	0.08835	0.2945	0.884	2.945
4	0.2262	0.7540	2.262	7.540
6	0.5088	1.6967	5.090	16.967

■ **About establishment environment**

Do not store or install the flowmeter:

- Where there is direct sunlight.
- Where excessive vibration or mechanical shock occurs.
- Where high temperature or high humidity conditions exist.
- Where corrosive atmospheres exist.
- Places that can be submerged under water.
- Where there is a sloped floor. To put the flowmeter temporarily on the floor, place it carefully with something, such as a block, to support it so that the flowmeter will not topple over.

In areas like the following, there may be the case that infrared switches do not function correctly. (If these are unavoidable, use an appropriate cover.)

- (1) Where unit (operation panel) is exposed to direct sunlight, reflection of light onto window pane and diffused light reflection.
- (2) Where smoke and steam may occur.
- (3) Where exposed to direct snow, ice or mud.

Ordering Information

1. When ordering the LF470 flowmeters, refer to Tables 4 to 5 (Specification Code). An entry must be made for each of the columns in each of these tables.
2. Fluid characteristics:
 - (1) Type of fluid to be measured and its characteristics
 - (2) Fluid temperature
 - (3) Fluid pressure
 - (4) Electrical conductivity of the fluid
3. Measuring range
4. I/O function setting
5. Ordering scope:

Flow calibration data: (required or not)
6. Other items

Specifications other than standard items

Consult a Toshiba representative before ordering when choosing materials of the wetted parts such as lining, electrodes, and grounding rings.

Table 4. Specification Code (LF470 Detector)

Model					Specification Code									Description	
1	2	3	4	5	6	7	8	9	10	11	12	13	14		
L	F	4	7	0											LF470 Flowmeter
					2										Meter size 1/10" (2.5 mm)
					4										1/6" (4 mm)
					6										1/4" (6 mm)
						D									Mounting Style Detector / Converter separate type(LF470/LF622)
							A								Pipe connection port (adapter) Rc (PT) 1/4 female screw (standard)
							B								Rc (PT) 1/8 female screw
							C								Rc (PT) 3/8 female screw
							D								Rc (PT) 1/2 female screw
							E								NPT1/4 female screw
							F								NPT3/8 female screw
							G								NPT1/8 female screw
							A								Pipe connection material 316 stainless steel (standard)
							D								Ti (titanium)
							E								Polyvinyl chloride (shock-resistance)+ Ta (Tantalum) for grounding plate
							F								Polyvinyl chloride (shock-resistance)+ Pt-Ir for grounding plate
							H								Hastelloy C (Equivalent)
								C							Packing used between main body and pipe connection adapter
								D							Acid-resistant ceramic
								G							Alkali-resistant ceramic Ammonia-resistance
									A						Mounting Not provided
									B						Provided, 304 stainless steel
										A					Flow and calibration velocity range 1.0 to 32.8 ft/s (standard range calibration)
										B					1.0 to 32.8 ft/s (specified range calibration)
											A				Cable length 5m (cable dia. 7mm)
											1				10m (cable dia. 7mm)
											2				15m (cable dia. 7mm)
											3				20m (cable dia. 7mm)
											4				25m (cable dia. 7mm)
											5				30m (cable dia. 7mm)
											B				5m or more (extension dia. 12mm+Scotch cast connection)
												A			Coating Phthalic acid resin coating pearl-gray colored (standard)
												Z			Other

Table 5. Specification Code for converters

Model				Specification Code										Contents	LF622 type	
1	2	3	4	5	6	7	8	9	10	11	12	13	14			
L	F	6	2												Electromagnetic flowmeter converter	
				2											Separate (Remote) type	●
					A										Purpose Standard	●
						A									Shape Separate type with case	●
							A								Converter mounting fitting None Panel, Accessory for wall mounting (BNP material: SUS304) Accessory for pipe installation (BNP material: SUS304)	○
							C									●
							E									○
								2							Digital input/output Digital output points 2 (DO1+DO2) +Digital input point 1 (DI)	●
									1						Current output and Communication function(Note1) Current output + HART communication PROFIBUS communication Modbus (RS485) communication	●
									2					○		
									3					○		
										1					Power supply(Note2) 100Vac-240Vac 50/60Hz, 110Vdc 24Vdc 110Vdc	●
										2				○		
										3				○		
												E			Instruction manual English	●

Code explanation: ●: Standard ○: Option —: Not available

Note 1: When PROFIBUS communication is provided, current output(4-20mA) and HART communication cannot be used.
When Modbus communication is provided, digital output points 1(DO1) and digital output points(DO2), digital input point 1(DI), HART communication cannot be used.

Refer Table 6 for more details.

Note2: Select 110Vdc for test report inspected under the condition of 110Vdc.

Table6. Communication functions and output selection table

Selection of Function		Availability of outputs			
Code (10 th digit)	Selected Communication	4-20mA	DO1	DO2	DI
1	HART	✓	✓	✓	✓
2	PROFIBUS	X	✓	✓	✓
3	Modbus	✓	✓ (Note)	X	X

Code explanation: ✓: Available X: Not Available

Note: When digital output 1 function and Modbus communication function are used at one time, TG (signal ground) of the Modbus communication function cannot be connected (2 line connection).

ISO9001 and ISO14001 are certified.

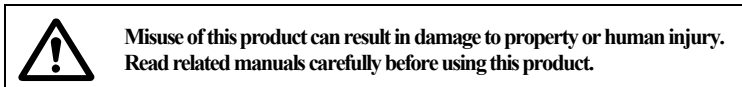

Specifications are subject to change without notice.

Printed in Japan 2011-6 (TDOC)

© TOSHIBA Corporation 2015

All Rights Reserved.

<http://www.toshiba.com/ind/>