

ROTATION FROM NDE

CCW

CW

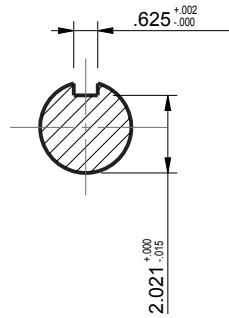
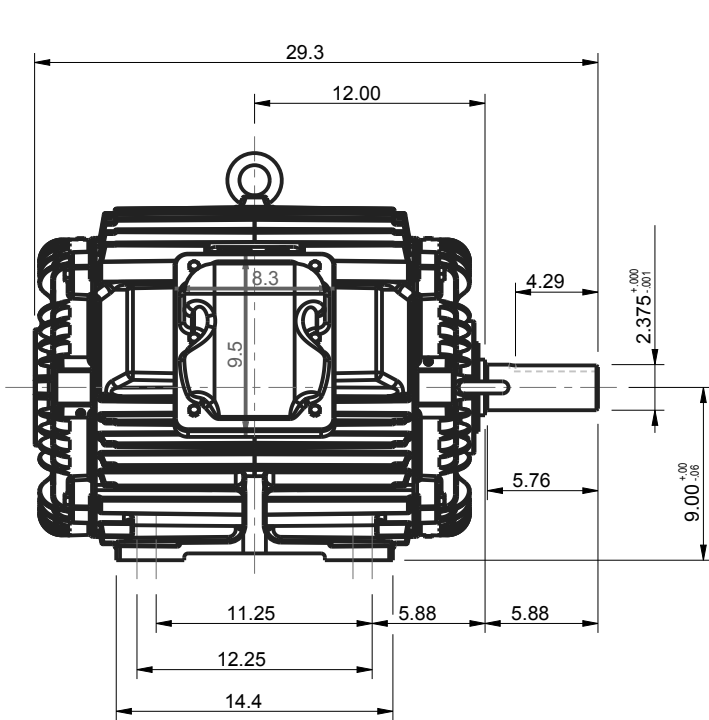

3.00" NPT CONDUIT

EYEBOLTS FOR VERTICAL LIFTING

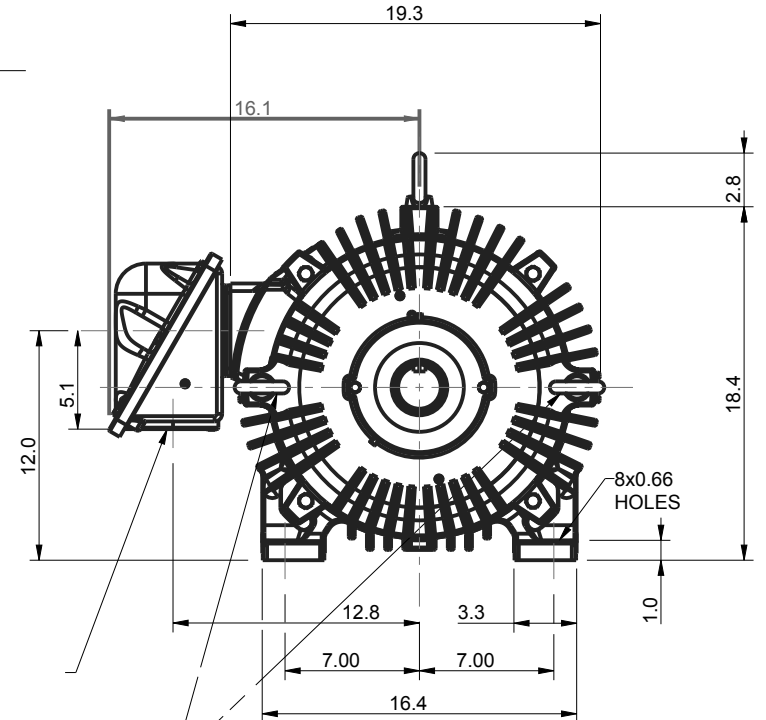

- NOTES:
1. MAIN CONDUIT BOX MAY BE ROTATED IN 90 INCREMENTS
 2. STANDARD PRODUCT USE BI-DIRECTIONAL FAN. OPPOSITE ROTATION AVAILABLE ONLY BY CONNECTION CHANGE.
 3. KEY DIMENSIONS EQUAL 0.625" x 0.625" x 4.25" (MOTOR SUPPLIED WITH KEY)

UNITS: INCHES

BEARINGS		APPROX. WEIGHT
LS	OS	
6314ZZC3	6312ZZC3	893 lbs

CUSTOMER: _____ MOTOR MODEL NO.: _____

P.O. NO.: _____ HP: _____ VOLTAGE: _____ RPM(SYN.): _____ HZ: _____

FRAME SIZE: 360T PRODUCT TYPE: COOLING TOWER

COMMENTS: _____

PER: _____ DATE: _____

TAG NUMBERS

- STANDARD (NO AUX. BOXES)
- RTD AUX. BOX
- SPACE HEATER AUX. BOX
- BEARING RTD's

TOSHIBA RESERVES THE RIGHT TO MAKE CHANGES OF TECHNICAL IMPROVEMENT AND THE DATA MAY CHANGE WITHOUT NOTICE PRELIMINARY

DO NOT USE FOR CONSTRUCTION, INSTALLATION, OR APPLICATION PURPOSES UNLESS THE DRAWING IS MARKED AS CERTIFIED CERTIFIED

TOSHIBA

TOSHIBA INTERNATIONAL CORPORATION

MDSLV505-07

TOTALLY ENCLOSED AIR OVER

3 PHASE INDUCTION MOTOR

F1 ASSEMBLY

SEVERE DUTY

EQP Global CT

XT SERIES

www.toshiba.com/ind

TYPICAL MOTOR PERFORMANCE DATA

Model: 0604FAGR41A-P

HP	kW	Pole	FL RPM	Frame	Voltage	Hz	Phase	FL Amps
60	45	4	1775	364T	230/460	60	3	136/68
Enclosure	IP	Ins. Class	S.F.	Duty	NEMA Nom. Eff.	NEMA Design	kVA Code	Ambient (°C)
TEAO	56	F	1.15	CONT	95.0	B		40 C

Load	HP	kW	Amperes	Efficiency (%)	Power Factor (%)
Full Load	60.00	44.7	67	95.3	87.1
¾ Load	45.00	33.6	52	94.8	85.2
½ Load	30.00	22.4	37	93.2	79.4
¼ Load	15.00	11.2	26	87.9	61.0
No Load			19.5		4.9
Locked Rotor			473		26.5

Torque				Rotor wk ² Inertia (lb-ft ²)
Full Load (lb-ft)	Locked Rotor (% FLT)	Pull Up (% FLT)	Break Down (% FLT)	
178	175	125	270	16.80

Safe Stall Time(s)		Sound Pressure dB(A) @ 1M	Bearings*		Approx. Motor Weight (lbs)
Cold	Hot		DE	NDE	
35	15	-	6314ZZC3	6312ZZC3	807

*Bearings are the only recommended spare part(s).

Motor Options:
Product Family:EQP Global Cooling Tower
Mounting:Footed,Shaft:T Shaft

Customer	
Customer PO	
Sales Order	
Project #	

Tag:

All characteristics are average expected values.

TOSHIBA INTERNATIONAL CORPORATION · HOUSTON, TEXAS U.S.A.

Engineering	Jrodrigu	Doc. Written By	D. Suarez	Doc.# / Rev	MPCF-1119 / 0
Engr. Date	7/25/2024	Doc. Approved By	M. Campbell	Doc. Issued	6/8/2011

SPEED TORQUE/CURRENT CURVE

Model: 0604FAGR41A-P

HP	kW	Pole	FL RPM	Frame	Voltage	Hz	Phase	FL Amps
60	45	4	1775	364T	230/460	60	3	136/68
Enclosure	IP	Ins. Class	S.F.	Duty	NEMA Nom. Eff.	NEMA Design	kVA Code	Ambient (°C)
TEAO	56	F	1.15	CONT	95.0	B		40 C
Locked Rotor Amps	Rotor wk ² Inertia (lb-ft ²)	Torque						Break Down (%)
		Full Load (lb-ft)	Locked Rotor (%)	Pull Up (%)				
473	16.80	178	175	125			270	

Design Values

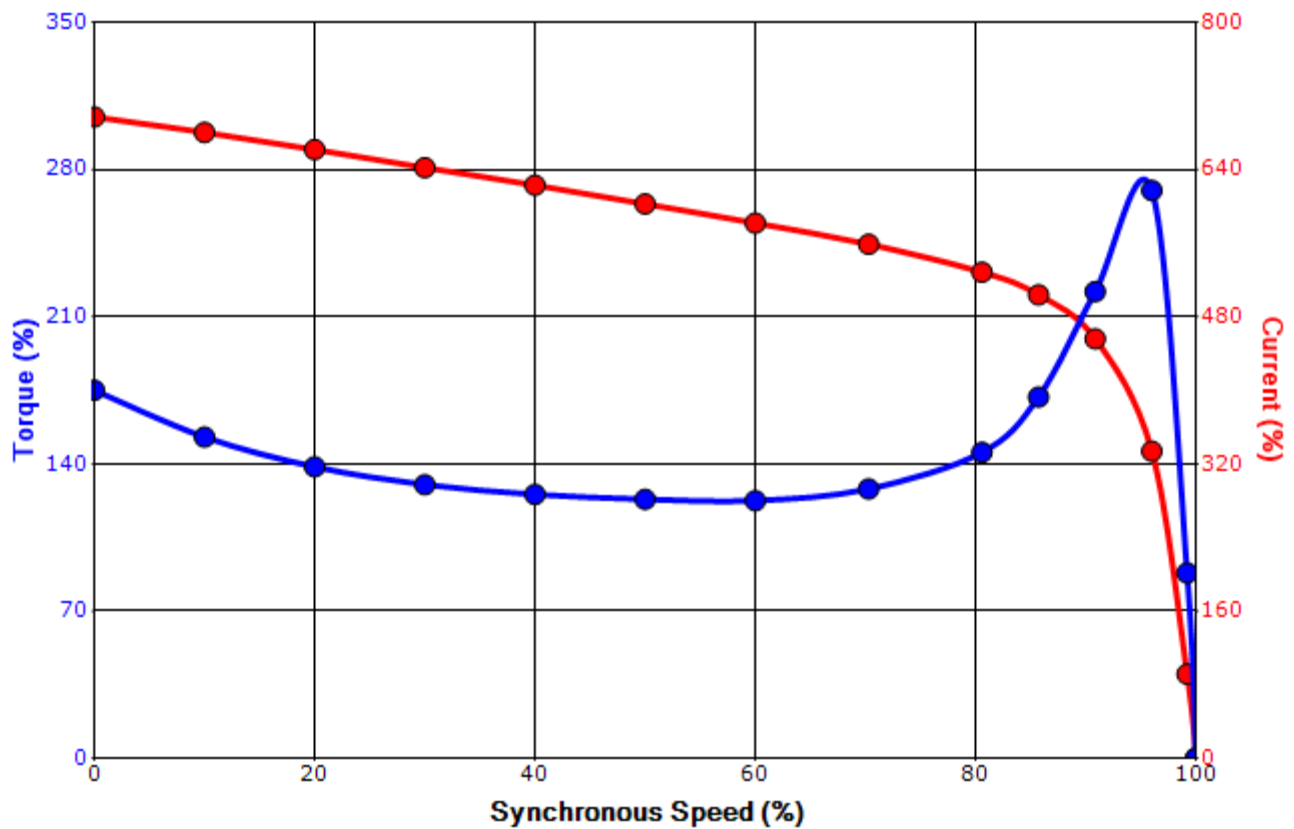

Customer		wk ² Load Inertia (lb-ft ²)	-
Customer PO		Load Type	-
Sales Order		Voltage (%)	100
Project #		Accel. Time	-

Tag:

All characteristics are average expected values.

TOSHIBA INTERNATIONAL CORPORATION · HOUSTON, TEXAS U.S.A.

Engineering	Jrodrigu	Doc. Written By	D. Suarez	Doc.# / Rev	MPCF-1121 / 0
Engr. Date	7/25/2024	Doc. Approved By	M. Campbell	Doc. Issued	6/8/2011

Motor Connection Diagrams
12 Leads

Across-the-Line Starting / Running Connections

Low Voltage Delta



High Voltage Delta



Switch L1 and L2 to reverse rotation

Suitable for Wye-Delta Starting and Limited Part-Winding-Starting.
Please Contact Toshiba International for specific connections.